

## UGM

Dimensions (mm)	51 x 65.2
Hight (mm)	15
Max. torque (cNm)	100
Ratios	12.5 ... 4800
Internal slipping clutch	none
Standard shaft (mm)	∅ 4 x 10
Weight (g)	45
Motor combination	Series UB and UD; Series UF without UFR3/4 and UFB3/4



## Standard Data

Mounting	any position
Axial thrust $F_A$	20 N
Lateral force $F_R$	100 N
Output shafts	∅ 4 x 10, other on request
Climatic class	wide-spread according to DIN IEC 60721-2-1
Ambient temperature operation	°C -15 ... +60
Ambient temperature storage	°C -40 ... +80

Ratios	12 1/2	16 2/3	25	50	100	120	150	200	240	300	400	500	600
	750	1000	1200	1500	4800								

## Order Reference

Type	Gearbox	UGM	100	N	N
Ratio	100				
Slipping clutch	N Without slipping clutch				
Shaft end	N ∅ 4 x 10, other on request				

## Dimensions

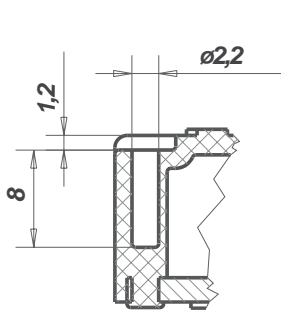

**E22:1**

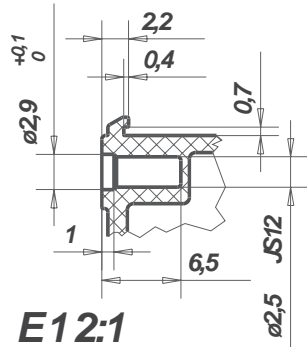
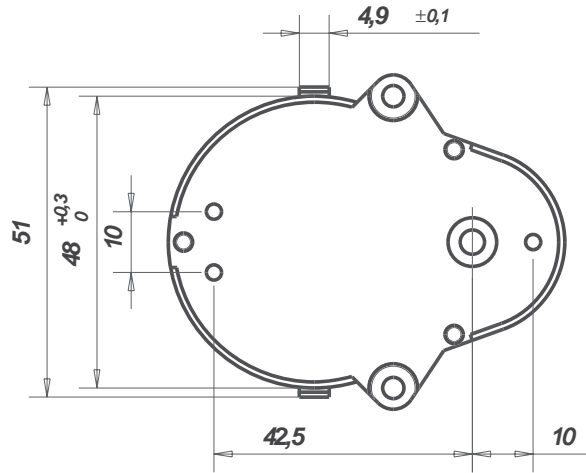

**E12:1**

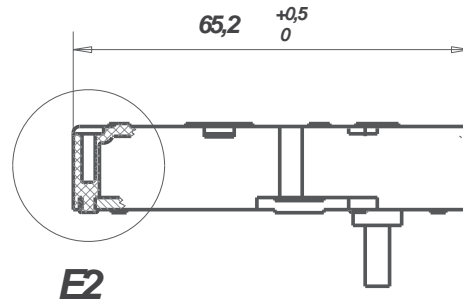

**E2**

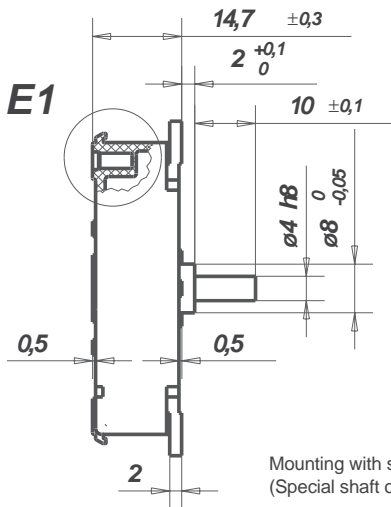

**E1**

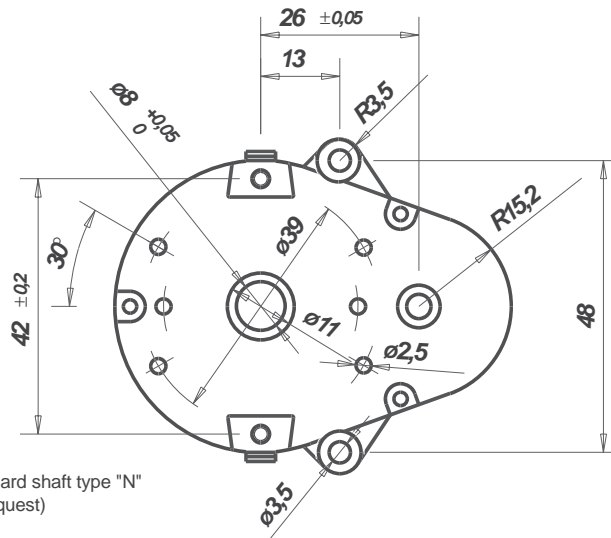

Mounting with standard shaft type "N"  
(Special shaft on request)

## Torque / ratio / life graph

