

Front view and mounting

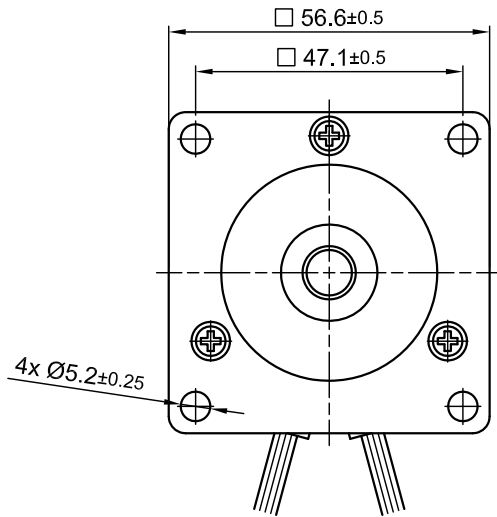

Side view

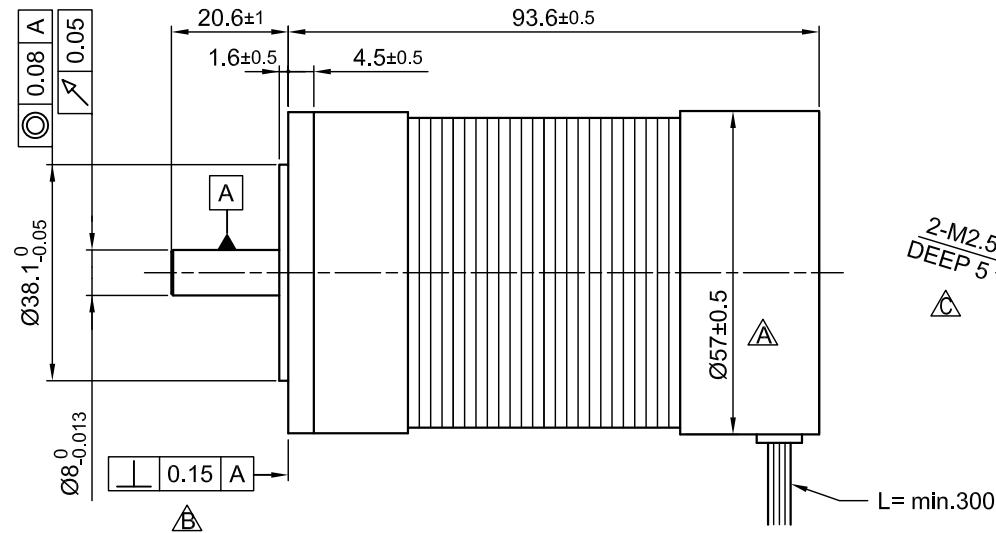

Rear view

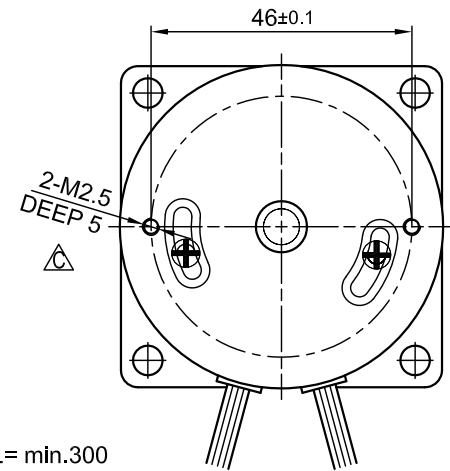

SPECIFICATION	CONNECTION	STAR
NO. OF POL./PHASE		6/3
VOLTAGE RATED (VDC)		24
CURRENT RATED/PEAK (AMP)		13.6/ 40
RESISTANCE/PHASE TO PHASE (Ohms) @20°C		0.135 ±10%
INDUCTANCE/PHASE TO PHASE (mH) @1KHz		0.2 ±20%
TORQUE RATED/PEAK (Nm) [lb-in]		0.6/1.8 [5.31/15.93]
TORQUE CONSTANT (Nm/A)/BACK-EMF (Vrms/kRPM)		0.044/ 3.7
POWER RATED (W)		220
SPEED RATED/NO LOAD (RPM)		3500/4500
ROTOR INERTIA (Kg-m <sup>2</sup> ) [lb-in <sup>2</sup> ]		17.3x10 <sup>-6</sup> [0.059]
WEIGHT (Kg) [lb]		0.95 [2.1]

PERMISSIBLE RADIAL+AXIAL FORCE

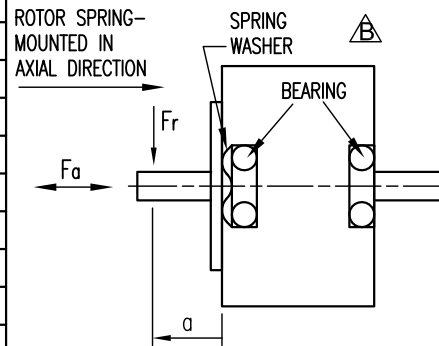

AXIAL-FORCE Fa (N)	Fa=15	
DISTANCE a (mm)	20	
RADIAL-FORCE Fr (N)	75	
	AXIAL	RADIAL
SHAFT PLAY (mm)	0.025	0.025
AT LOAD MAX: (N)	40	4.6

WIRING DIAGRAM

	COLOR	FUNCTION	LEAD GAUGE
MOTOR 6 POL.	YE	U	UL1332 AWG18
	RD	V	
	BK	W	
HALL 18 IMPL. REV.	RD	+5V	UL1430 AWG26
	BU	H1	
	GN	H2	
	WH	H3	
	BK	GND	

CW from shaft side

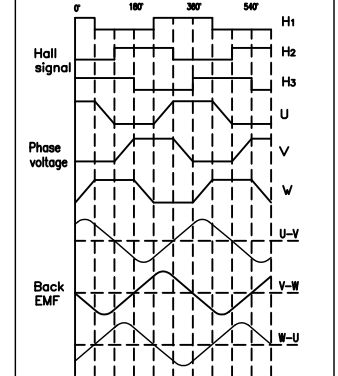

STAR CONNECTION

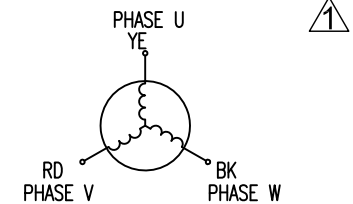

REV	DESCRIPTION	DATE	APVD
C	CHANGE VIEW	21.02.14	J.D.
B	CHG. RECT.+SPRING WASHER	17.01.14	J.D.
1	CORR. HALL ASSIGNM.	13.06.14	J.D.



DB59C024035-A

SCALE FREE	APVD	G.S.	26.09.13
DIN ISO 2768-m	CHKD		
	DRN	A.S.	26.09.13
	SIGNATURE	DATE	

BRUSHLESS DC MOTOR

DWG.NO

DB59C024035-A