

Battery Charger Model GSK-819

This kit contains parts to assemble a Lithium-ion Polymer battery charger. These batteries are becoming popular with radio controlled devices, iPods[®], MP3, and laptop computers.

Technical Specifications

- Power Source: 12-15 VDC, more than 600 mA
- Charge Current: 400 mA or 600 mA (selectable)
- Charge: 1 to 2 cells
- Charge Indicator: LED
- Cut Off: Automatic cut-off circuit when battery fully charged
- Power source polarity protected
- PCB Dimensions: 3.73 x 2.44 inches

Operating Principles

When power source is applied IC2 will regulate the voltage to a suitable amount for charging. Integrated circuits control the output voltage, switch SW1 controls selectable charge current (H = 600 mA and L = 400 mA), and switch SW2 controls the number of cells (1 cell 3.7 V) an (2 cells 7.4 V). When battery is fully charged IC1 applies voltage to IC2 and initiates cut-off circuit. LED's are on when battery is charging and off when battery is fully charged.

Circuit Assembly

Please refer to Figures 1, 2, and 3 for aid in component placement. It is recommended to start with lower components i.e. diodes, resistors, electrolyte capacitors, and transistors. Be careful to check polarity with Figure 2 before soldering. Take extra precaution to ensure electrolytic capacitors are

inserted correctly. If a problem is detected it is best too use a desoldering pump or desoldering braids to remove component. This will minimize potential damage to the printed circuit board.

Testing

Connect the power source, LED LSW and LED L5V should light. Measure voltage at TP point and adjust voltage to 4.2 V using VR1K. Select charging current using SW1 (H = 600 mA, L = 400 mA), select number of cells in battery using SW2 (position 1 = 1 cell, position 2 = 2 cells).

Connect Li-Po battery to charger at position "OUT," LED "Charge" will light to indicate battery is charging. When battery is fully charged LED "LSW" and LED "Charge" will be off. Disconnect battery from charger and wait for the LED "LSW" to turn on before trying to charge another battery. Charger will not charge until the LED "LSW" is on.

Troubleshooting

This circuit has only a few components, the main cause of problems will come from misplaced components or faulty soldering. Utilize Figure 2 to ensure proper placement/polarity and then check solder points for connectivity.

Accessories

Use GSB-04 (sold separately) to house the PCB and batteries.

iPod[®] is a registered trademark of Apple Inc.

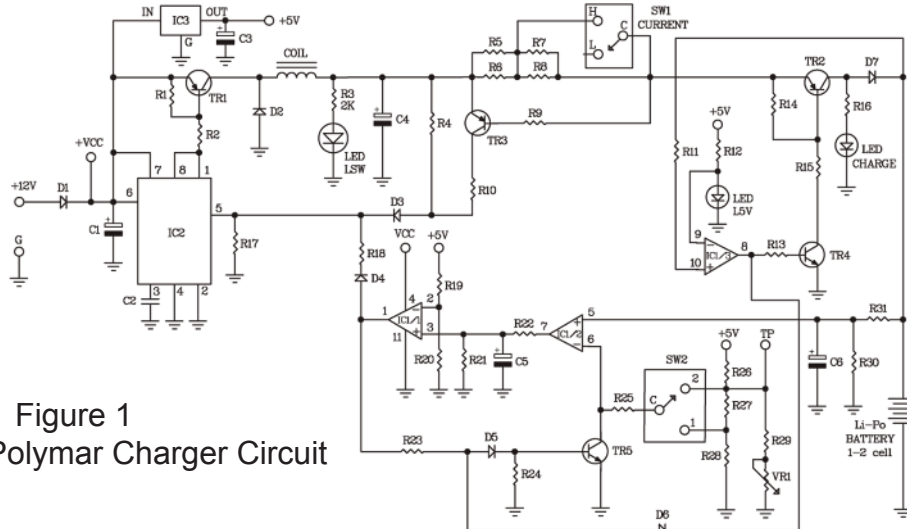
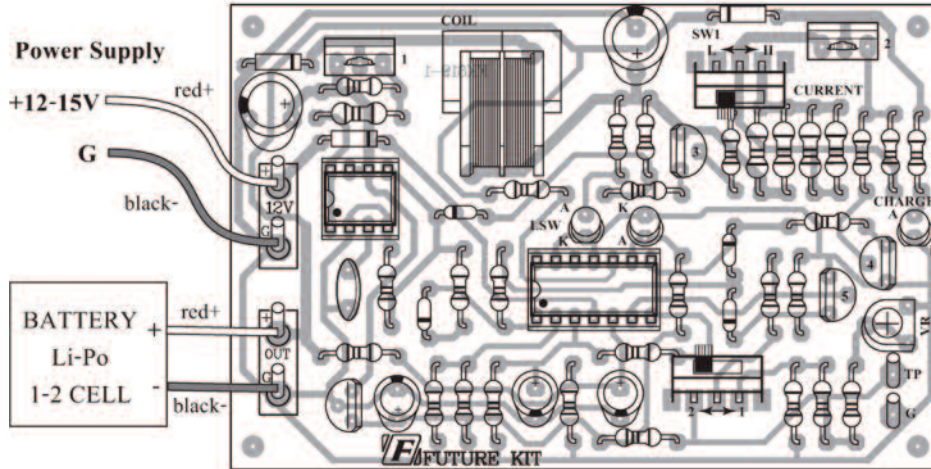

Figure 1
Lithium-ion Polymer Charger Circuit

Figure 2 Assembling circuit



GSK-819

SW1:
Select the current charging.
L = 400 mA and H = 600 mA

SW2:
Select the number of cell.
1 = 1 cell (3.7 V)
2 = 2 cell (7.4 V)

Resistors ¼ W

R1, R26	150 Ω	brown – green – brown – gold
R3, R12, R16	2 kΩ	red – black – red – gold
R4	6 kΩ	blue – gray – red – gold
R9	3 kΩ	orange – black – red – gold
R10	300 Ω	orange – black – brown – gold
R11, R13, R19, R20, R23, R24, R30, R31	10 kΩ	brown – black – orange – gold
R14, R17, R18, R25, R27, R29	1 kΩ	brown – black – red – gold
R15	560 Ω	green – blue – brown – gold
R21	1 MΩ	brown – black – green – gold
R22	50 kΩ	green – black – orange – gold

Resistors ½ W

R2	500 Ω	green – black – brown – gold
R5, R6	2 Ω	red – black – gold – gold
R7, R8	1 Ω	brown – black – gold – gold

Potentiometer

VR1 102 or 13 or 1 kΩ

Electrolytic Capacitors

C1, C4	470 μF
C3, C6	10 μF
C5	47 μF

Ceramic Capacitor

C2 680 or 680 pF

Figure 3 Installing components

