



A Tallysman Accutenna™ TW2710 Magnet Mount Multi-Constellation Antenna

The TW2710 employs Tallysman's unique Accutenna™ technology covering the BeiDou B1, Galileo E1, GPS L1, GLONASS L1 and SBAS (WAAS, QZSS, EGNOS & MSAS) frequency band (1557 to 1606 MHz). It is especially designed for precision industrial, agricultural and military applications. It provides truly circular response over its entire bandwidth thereby producing superior multipath signal rejection.

The TW2710 has a low axial ratio, excellent phase linear response and a tight phase centre variation, providing the performance normally associated with higher priced antennas.

The TW2710 features a dual-feed wideband patch element, with one LNA per feed, a mid section Combiner and SAW filter, and a final output gain stage.

The TW2710 is housed in a compact, industrial-grade weather-proof, magnet mount enclosure, and is available with a variety of connectors and cable lengths.

The antenna can be ordered without the magnet. In such cases, the magnet is replaced with a plastic plug to provide a smooth under surface

Applications

- High Accuracy & Mission Critical GNSS
- Precision Agriculture, Mining & Construction
- Military & Security
- Avionics
- Law Enforcement & Public Safety
- Fleet Management & Asset Tracking

Features

- Covers B1 / E1 / L1 / G1 Frequencies
- Great axial ratio: 1 typ., 3 dB max
- Low noise LNA: ≤ 1 dB
- High rejection SAW filter
- LNA gain: 28 dB typ.
- Low current: 15 mA typ.
- Wide voltage input range: 2.5 to 16 VDC



Dimensions (mm)

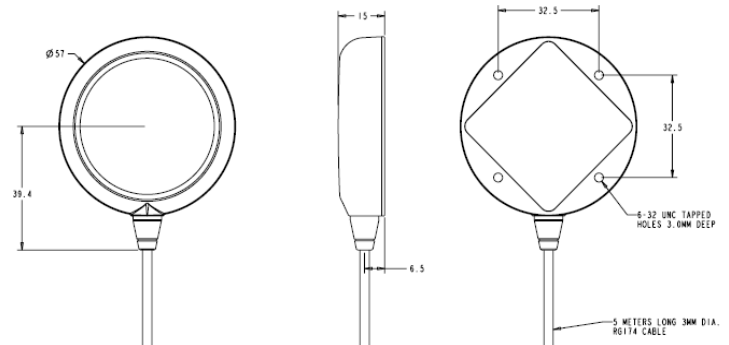

Dimensions (mm)

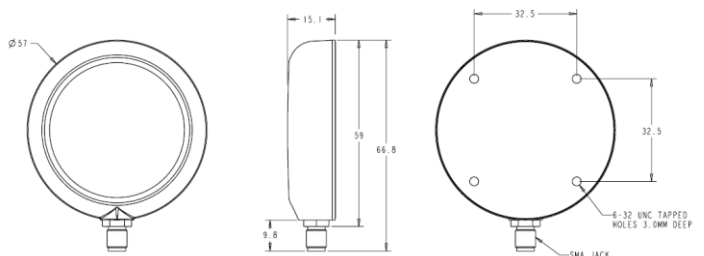

Benefits

- Excellent multipath rejection
- Increased system accuracy
- Excellent signal to noise ratio
- Great out of band signal rejection
- Ideal for harsh environments
- RoHS compliant



TW2710 Magnet Mount Multi-Constellation Antenna

Specifications $V_{cc} = 3V$, over full bandwidth, $T=25^{\circ}C$

Antenna

Architecture	Dual, Quadrature Feeds
2 dB Bandwidth	49 MHz
Antenna Gain (with 100mm ground plane)	4.75 dBic
Axial Ratio at Zenith over full bandwidth	<2 dB typ, ≤ 3 dB max

Electrical

Architecture	One LNA per feed line, mid section SAW filter
Filtered LNA Frequency Bandwidth	1557 to 1606 MHz
Polarization	RHCP
LNA Gain	28 dB min.
Gain flatness	+/- 2 dB, 1557 to 1606 MHz
Out-of-Band Rejection	<1500 MHz <1540 MHz >1640 MHz
VSWR (at LNA output)	<1.5:1
Noise Figure	≤ 1 dB typ.
Supply Voltage Range (over coaxial cable)	+2.5 to 16 VDC nominal (12VDC recommended maximum)
Supply Current	15 mA typ., 22mA max. (@85°C)
ESD Circuit Protection	15 KV air discharge

Mechanicals & Environmental

Mechanical Size	57 mm dia. x 15 mm H
Connectors	Please refer to Ordering Information, below
Cable	RG174
Operating Temp. Range	-40°C to +85°C
Enclosure	Radome: ASA Plastic, Base: Zamak white metal
Weight	110g
Attachment Method	Magnet or permanent (pre-tapped 4 x 6-32 UNC)
Environmental	IP67 and RoHS compliant
Shock	Vertical axis: 50G, other axes: 30G
Vibration	3 axis, sweep = 15 min, 10 to 200 Hz sweep: 3G

Ordering Information

TW2710 – Multi-Constellation antenna, 33-2710-xx-yyyy
Where xx = connector type and yyyy = cable length in mm

Please refer to the Ordering Guide (<http://www.tallysman.com/wp-content/uploads/Current-Ordering-Guide.pdf>) for the current and complete list of available connectors.

Tallysman Wireless Inc

106 Schneider Road, Unit 3
Ottawa ON K2K 1Y2 Canada

Tel 613 591 3131

Fax 613 591 3121

sales@tallysman.com

The information provided herein is intended as a guide only and is subject to change without notice. This document is not to be regarded as a guarantee of performance. Tallysman Wireless Inc. hereby disclaims any or all warranties and liabilities of any kind. © 2011 Tallysman Wireless Inc. All rights reserved.

Rev 3.2