

AC axial fan

straight blades (A series), single-intake

ebm-papst Mulfingen GmbH & Co. KG

Bachmühle 2 · D-74673 Mulfingen

Phone +49 7938 81-0

Fax +49 7938 81-110

info1@de.ebmpapst.com

www.ebmpapst.com

Limited partnership · Headquarters Mulfingen

Amtsgericht (court of registration) Stuttgart · HRA 590344

General partner Elektrobau Mulfingen GmbH · Headquarters Mulfingen

Amtsgericht (court of registration) Stuttgart · HRB 590142

Nominal data

Type	A2D250-AA06-71		
Motor	M2D068-DF		
Phase		3~	3~
Nominal voltage	VAC	265	460
Wiring		Δ	Y
Frequency	Hz	60	60
Method of obtaining data		fa	fa
Valid for approval/standard		CE	CE
Speed	min ⁻¹	2900	2900
Power consumption	W	150	150
Current draw	A	0.38	0.22
Max. back pressure	Pa	125	125
Min. ambient temperature	°C	-25	-25
Max. ambient temperature	°C	65	65

ml = Max. load · me = Max. efficiency · fa = Free air · cs = Customer specification · ce = Customer equipment
Subject to change



Technical description

Weight	2.4 kg
Fan size	250 mm
Rotor surface	Painted black
Terminal box material	Die-cast aluminum
Terminal box cover material	Die-cast aluminum
Impeller material	Sheet steel, painted black
Number of blades	5
Airflow direction	"A"
Direction of rotation	Clockwise, viewed toward rotor
Degree of protection	IP44; installation- and position-dependent
Insulation class	"B"
Moisture (F) / Environmental (H) protection class	F1-2
Max. permitted ambient temp. for motor (transport/storage)	+ 80 °C
Min. permitted ambient temp. for motor (transport/storage)	- 40 °C
Installation position	Shaft horizontal or rotor on bottom; rotor on top on request
Condensation drainage holes	None
Mode	S1
Motor storage	Ball bearing
Touch current according to IEC 60990 (measuring circuit Fig. 4, TN system)	< 0.75 mA
Electrical hookup	Via terminal box
With cable	Axial
Protection class	I (with customer connection of protective earth)
Conformity with standards	EN 60335-1, motor does not have factory-installed overheating protection

Product drawing

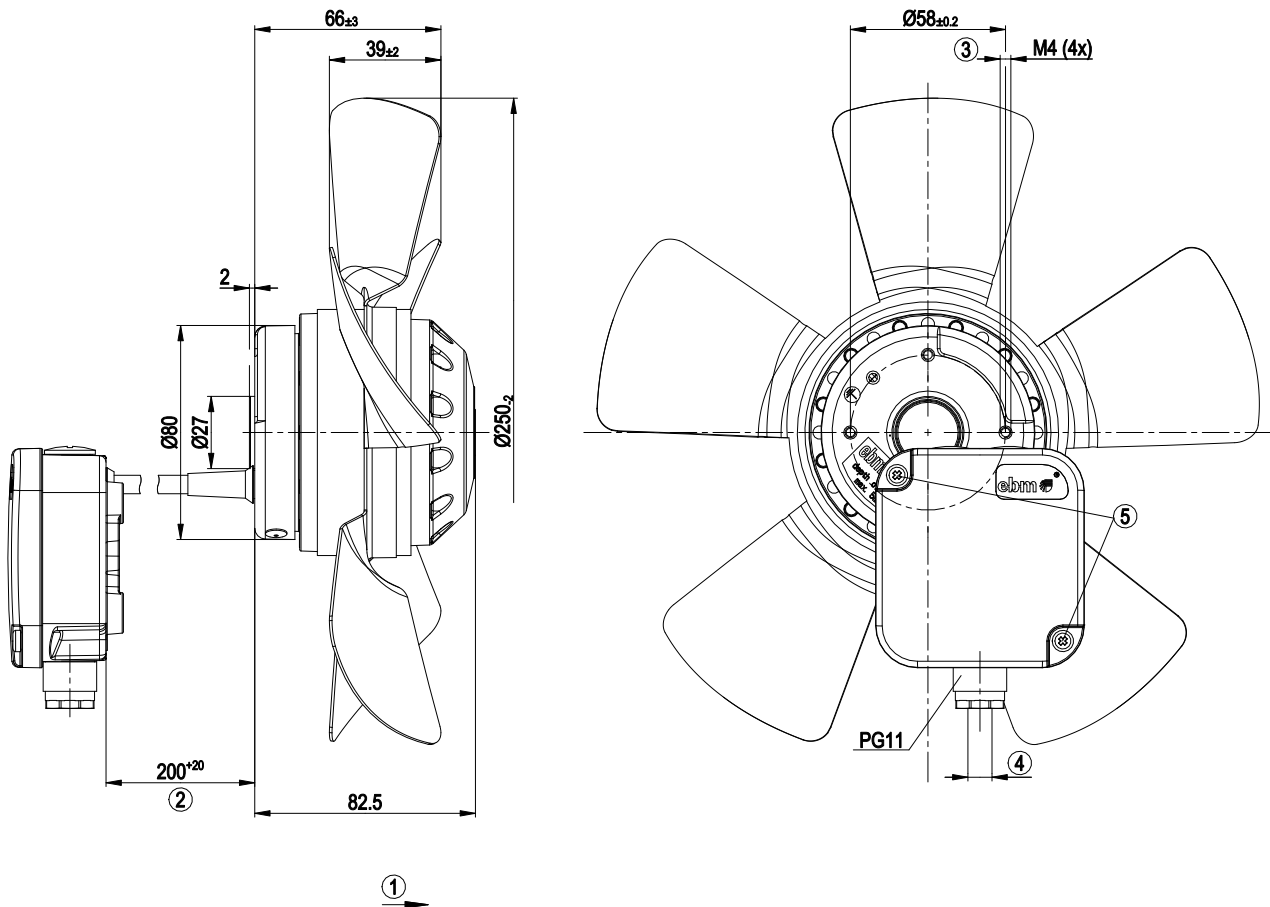

1	Direction of air flow "A"
2	Cable PVC 7G 0.5 mm ²
3	Max. clearance for screw 5 mm
4	Cable diameter min. 6 mm, max. 9 mm
5	Tightening torque 1.3 ± 0.2 Nm

Connection diagram

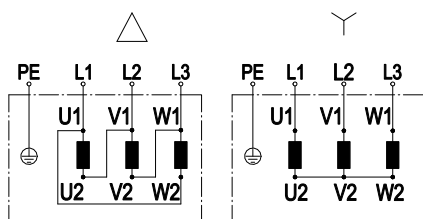

Change of rotation direction by reversing two phases

	Three-phase motor	Δ	Delta connection	Y	Star connection
L1	= U1 = black	L2	= V1 = blue	L3	= W1 = brown
U2	green	V2	white	W2	yellow
PE	green/yellow				

Curves: Air performance 60 Hz

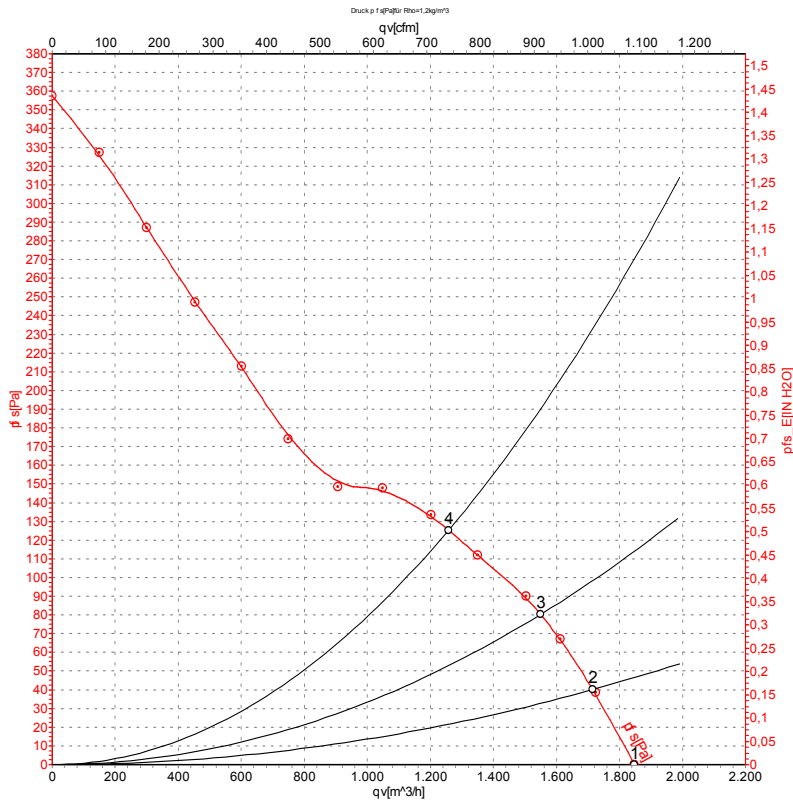

Measurement: LU-110509

Air performance measured according to ISO 5801 installation category A. For detailed information on the measurement setup, contact ebm-papst. Intake sound level: Sound power level according to ISO 13347 / sound pressure level measured at 1 m distance from fan axis. The values given are valid under the specified measuring conditions and may vary due to conditions of installation. For deviations from the standard configuration, the parameters have to be checked on the installed unit.

Measured values

	Wired	U	f	n	P _e	I	qv	p _{fs}
		V	Hz	min ⁻¹	W	A	m ³ /h	Pa
1	Y	460	60	2900	150	0.22	1850	0
2	Y	460	60	2835	160	0.23	1715	40
3	Y	460	60	2800	166	0.23	1550	80
4	Y	460	60	2765	172	0.24	1260	125

Wired = Wiring · U = Power supply · f = Frequency · n = Speed · P_e = Power consumption · I = Current draw · qv = Air flow · p_{fs} = Pressure increase

