

40mm sq.

San Ace 40

10mm thick (9P type), 15mm thick (9GA type),
 15mm thick (9P type), 20mm thick (9GA type),
 20mm thick (9P type), 28mm thick (9GA type),
 28mm thick (9GE type), 28mm thick (9GV type),
 28mm thick (9P type)



General Specifications

- Material Frame: Plastics (Flammability: UL94V-0),
 Impeller: Plastics (Flammability: UL94V-0)
- Expected Life Refer to specifications (L10: Survival rate: 90% at 60°C ,
 rated voltage, and continuously run in a free air state)
- Lead Wire ⊕red ⊖black (Sensor) yellow (Control) brown
- Storage Temperature -30°C to +70°C (Non-condensing)

40×40×20mm (Mass : 35g) **9GA type** High Airflow Low Power Consumption Fan



Specifications The following nos. have PWM controls, pulse sensors, and ribs.

Model No.	Rated Voltage [V]	Operating Voltage Range [V]	PWM duty cycle* [%]	Rated Current [A]	Rated Input [W]	Rated Speed [min ⁻¹]	Max. Airflow [m ³ /min] [CFM]	Max. Static Pressure [Pa] [inchH ₂ O]	SPL [dB(A)]	Operating Temperature [°C]	Expected Life [h]	
9GA0405P6H001 ^(Note)	5	4.5 to 5.5	100	0.35	1.75	12,400	0.33 11.7	191 0.77	40	-20 to +70	40,000	
9GA0405P6F001 ^(Note)			100	0.18	0.9	8,000	0.21 7.4	79.5 0.32	28		60,000	
9GA0412P6G001	12	10.2 to 13.8	100	0.23	2.76	16,000	0.42 14.8	318 1.28	47		40,000	
			0	0.04	0.48	3,800	0.10 3.5	17.9 0.07	14		60,000	
100			0.14	1.68	12,400	0.33 11.7	191 0.77	40				
0			0.04	0.48	3,800	0.10 3.5	17.9 0.07	14				
9GA0412P6H001	12	10.2 to 13.8	100	0.08	0.96	8,000	0.21 7.4	79.5 0.32	28			
			0	0.03	0.36	2,200	0.06 2.1	6.0 0.02	10			
9GA0412P6F001			12	10.2 to 13.8	100	0.13	3.12	16,000	0.42 14.8		318 1.28	47
					100	0.08	1.92	12,400	0.33 11.7		191 0.77	40
9GA0424P6G001 ^(Note)	24	20.4 to 27.6			100	0.13	3.12	16,000	0.42 14.8		318 1.28	47
					100	0.08	1.92	12,400	0.33 11.7		191 0.77	40
9GA0424P6H001 ^(Note)			24	20.4 to 27.6	100	0.13	3.12	16,000	0.42 14.8	318 1.28	47	
					100	0.08	1.92	12,400	0.33 11.7	191 0.77	40	
9GA0424P6F001 ^(Note)	24	20.4 to 27.6			100	0.13	3.12	16,000	0.42 14.8	318 1.28	47	
					100	0.08	1.92	12,400	0.33 11.7	191 0.77	40	

Note: Rated voltage 5V and 24V fans do not rotate when PWM duty cycle is 0%.

*PWM Frequency : 25kHz

Some models can also be equipped without sensors or with pulse sensors (no PWM control functions) as an option. Please refer to the index (pp. 417 to 437).

Dimensions (unit : mm)

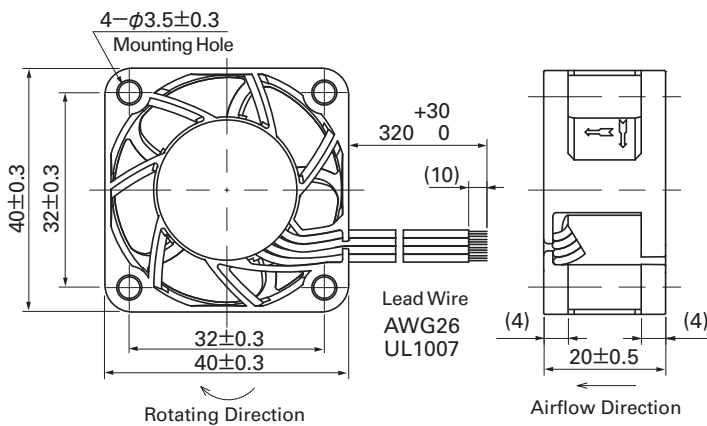

Reference Dimension of Mounting Holes and Vent Opening (unit : mm)

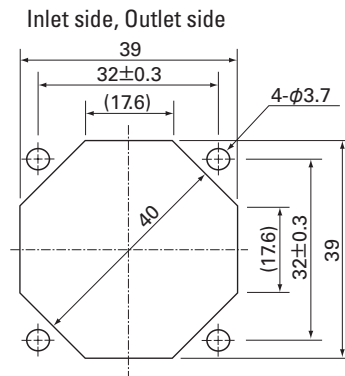

Options (unit : mm)

Finger Guards

Model : 109-059 Surface treatment : Nickel-chrome plating (silver)
 : 109-059H : Cation electropainting (black)

Color

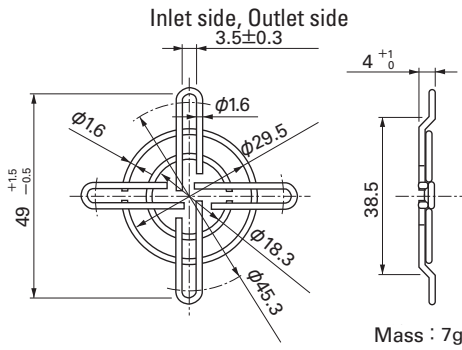

Airflow - Static Pressure Characteristics

PWM Duty Cycle

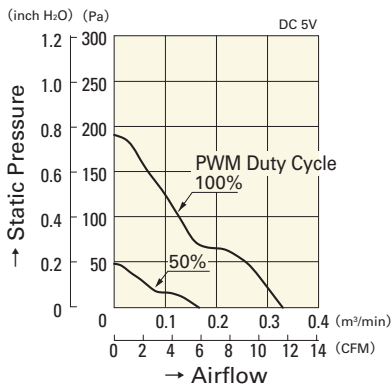

9GA0405P6H001

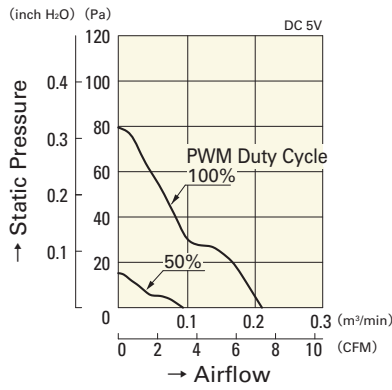

9GA0405P6F001

Operating Voltage Range

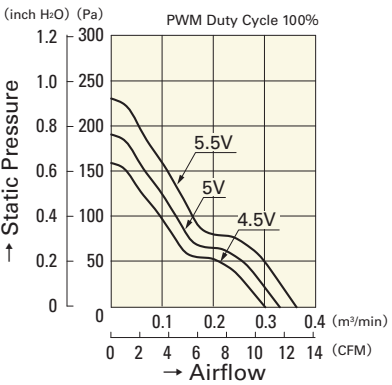

9GA0405P6H001

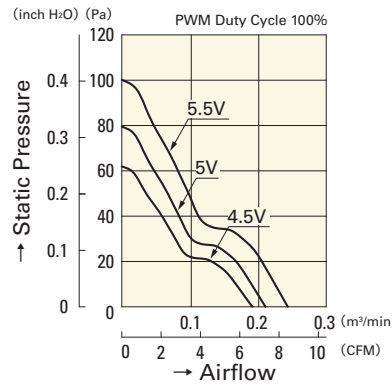

9GA0405P6F001

PWM Duty - Speed Characteristics Example

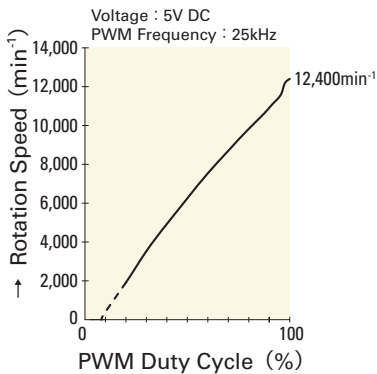

9GA0405P6H001

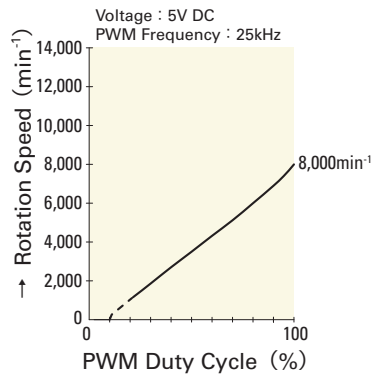

9GA0405P6F001

40mm sq.

San Ace 40

40×40×20mm [Mass : 35g]

Airflow - Static Pressure Characteristics

PWM Duty Cycle

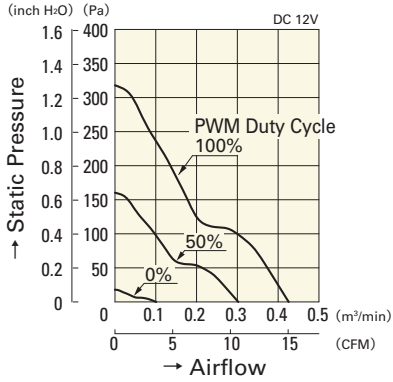

9GA0412P6G001

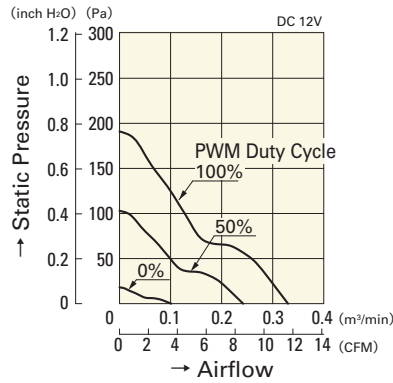

9GA0412P6H001

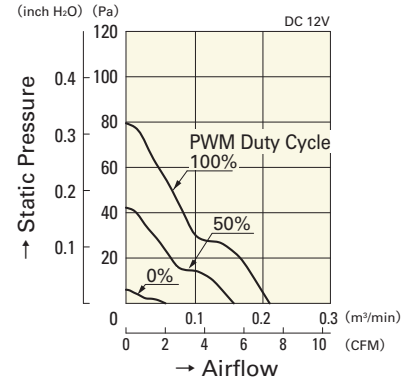

9GA0412P6F001

Operating Voltage Range

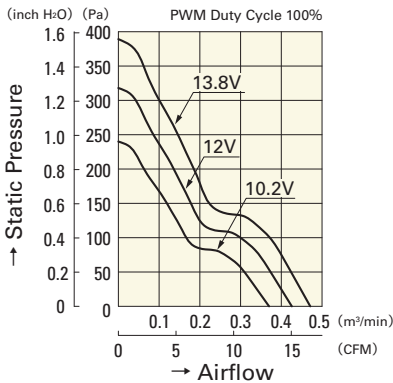

9GA0412P6G001

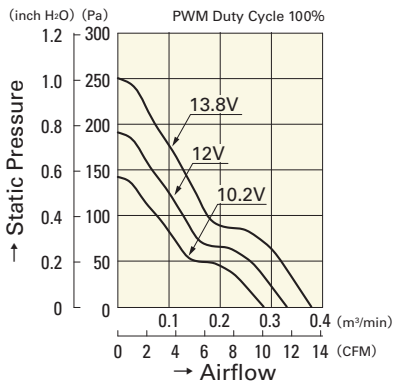

9GA0412P6H001

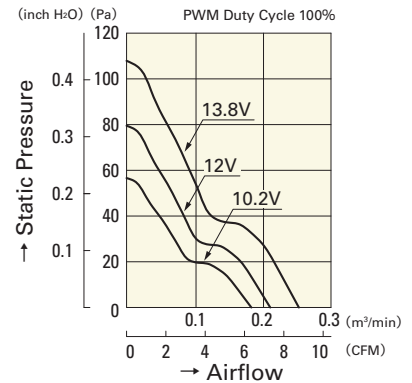

9GA0412P6F001

PWM Duty - Speed Characteristics Example

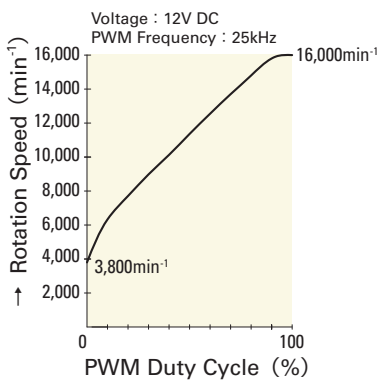

9GA0412P6G001

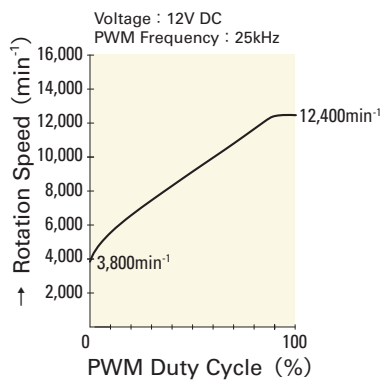

9GA0412P6H001

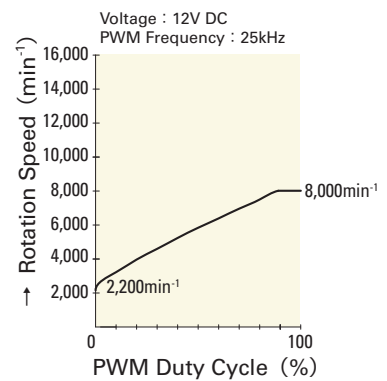

9GA0412P6F001

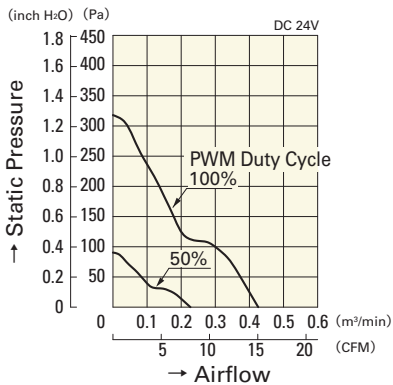

9GA0424P6G001

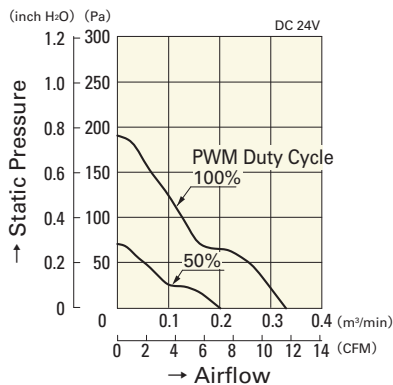

9GA0424P6H001

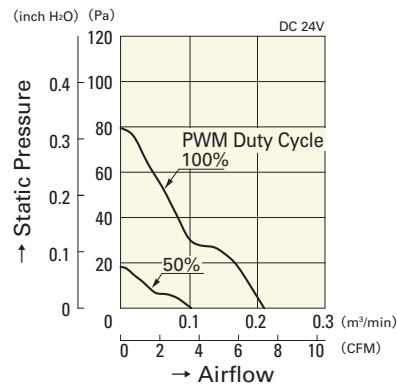

9GA0424P6F001

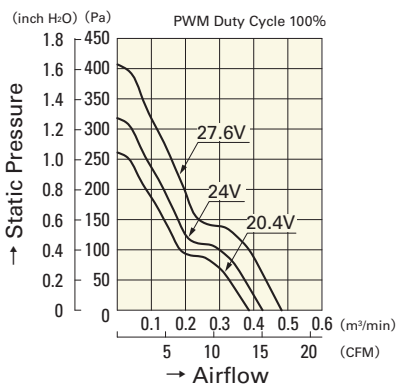

9GA0424P6G001

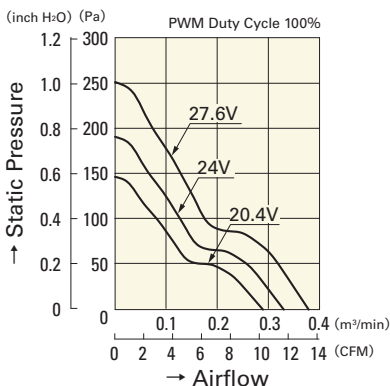

9GA0424P6H001

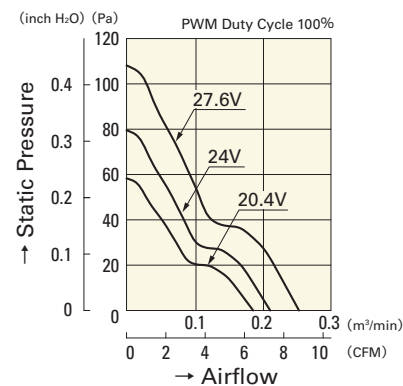

9GA0424P6F001

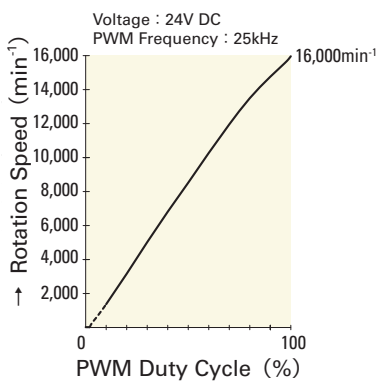

9GA0424P6G001

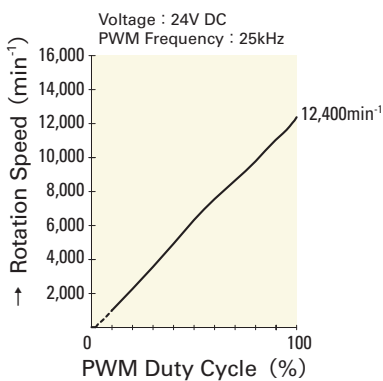

9GA0424P6H001

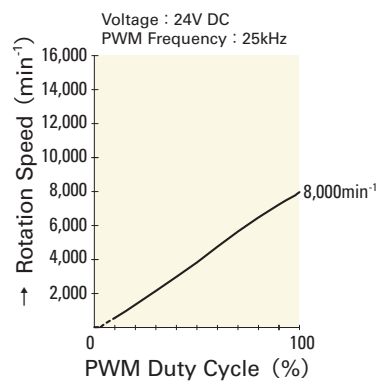

9GA0424P6F001