

ENERGIZER CR1025

Lithium Coin



Industry Standard Dimensions

mm (inches)



This Battery has Underwriters Laboratories component Recognition

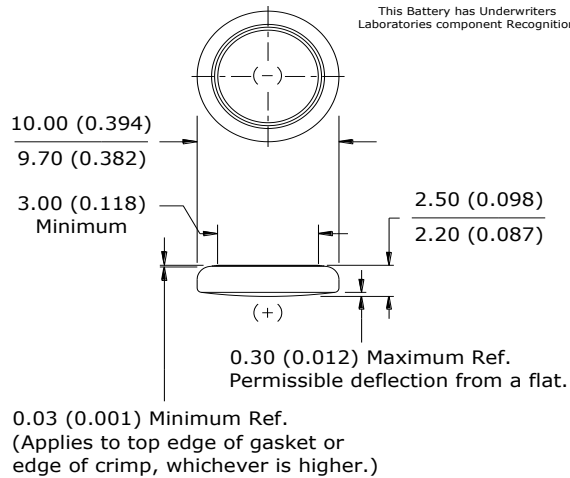

Specifications

Classification:	"Lithium Coin"
Chemical System:	Lithium / Manganese Dioxide (Li/MnO ₂)
Designation:	ANSI-5033LC, IEC-CR1025
Nominal Voltage:	3.0 Volts
Typical Capacity:	30 mAh (to 2.0 volts) (Rated at 68K ohms at 21°C)
Typical Weight:	0.7 grams (0.02 oz.)
Typical Volume:	0.2 cubic centimeters (0.01 cubic inch)
Max Rev Charge:	1 microampere
Energy Density:	124 milliwatt hr/g, 435 milliwatt hr/cc
Typical Li Content:	0.009 grams (0.0003 oz.)
UL Recognized:	MH29980
Operating Temp:	-30C to 60C
Self Discharge:	~1% / year

Safety:



(1) KEEP OUT OF REACH OF CHILDREN. Swallowing may lead to serious injury or death in as little as 2 hours due to chemical burns and potential perforation of the esophagus. **Immediately see doctor; have doctor phone (202) 625-3333.**

(2) Battery compartment design. To prevent children from removing batteries, battery compartments should be designed with one of the following methods: a) a tool such as screwdriver or coin is required to open battery compartment or b) the battery compartment door/cover requires the application of a minimum of two independent and simultaneous movements of the securing mechanism to open by hand. Screws should remain captive with the battery door or cover.

Typical Discharge Characteristics

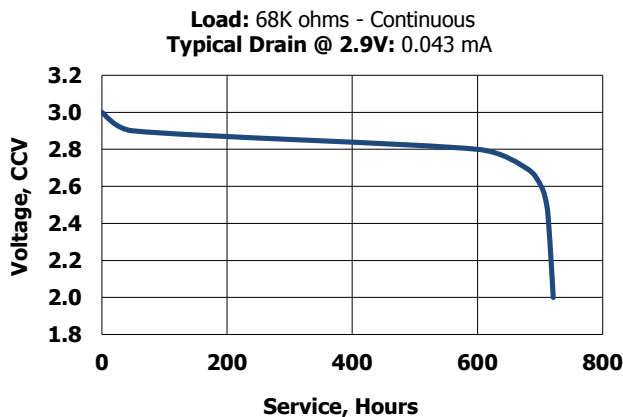

Cross Section

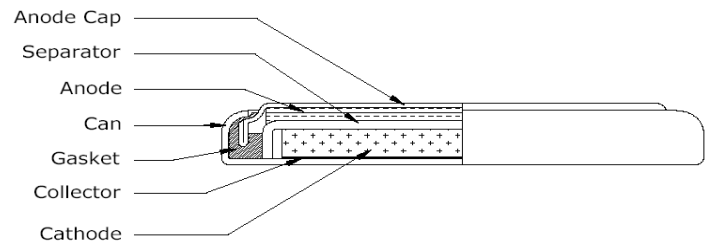

Simulated Application test

Typical Performance at 21°C (70°F)

Schedule:	Typical Drains: at 2.9V (mA)	Load (ohms)	Cutoff 2.0V (hours)
Continuous	0.043	68,000	721

Pack Quantity : 1
Manufacturers Part Number : E300163500