

**ON Semiconductor®**



# DATASHEET

# AX8052F131

---

**SoC Ultra-Low Power RF-  
Microcontroller for the 400-  
470 MHz and 800-940 MHz  
bands**

Revision 2



## Table of Contents

<b>1. Overview</b> .....	<b>5</b>
1.1. Features .....	5
1.2. Applications .....	6
<b>2. Block Diagram</b> .....	<b>7</b>
<b>3. Pin Function Descriptions</b> .....	<b>8</b>
3.1. Alternate Pin Functions.....	9
3.2. Pinout Drawing.....	10
<b>4. Specifications</b> .....	<b>11</b>
4.1. Absolute Maximum Ratings .....	11
4.2. DC Characteristics .....	12
Supplies.....	12
Logic .....	14
4.3. AC Characteristics.....	15
Crystal Oscillator (RF reference oscillator) .....	15
RF Frequency Generation Subsystem (Synthesizer) .....	16
Transmitter .....	18
Low Frequency Crystal Oscillator.....	19
Internal Low Power Oscillator .....	19
Internal RC Oscillator.....	19
Microcontroller .....	20
ADC / Comparator / Temperature Sensor .....	21
<b>5. Circuit Description</b> .....	<b>22</b>
5.1. Microcontroller .....	23
Memory Architecture .....	23
Memory Map.....	24
Power Management .....	25
Clocking.....	26
Reset and Interrupts .....	27



Debugging .....	27
5.2. Timer, Output Compare and Input Capture .....	28
5.3. UART .....	28
5.4. SPI Master/Slave Controller .....	28
5.5. ADC, Analog Comparators and Temperature Sensor .....	29
5.6. DMA Controller .....	30
5.7. AES Engine .....	30
5.8. Crystal Oscillator (RF reference oscillator) .....	30
5.9. SYSCLK Output .....	31
5.10. Power-on-reset (POR) and RESET_N Input .....	31
5.11. Ports .....	32
<b>6. Transmitter .....</b>	<b>33</b>
6.1. RF Frequency Generation Subsystem .....	33
VCO .....	33
VCO Auto-Ranging .....	33
Loop Filter and Charge Pump .....	34
Registers .....	34
6.2. RF Input and Output Stage (ANTP/ANTN) .....	35
6.3. Encoder .....	35
6.4. Framing and FIFO .....	36
HDLC Mode .....	37
RAW Mode .....	37
802.15.4 (ZigBee) DSSS .....	37
6.5. Modulator .....	38
6.6. PWRMODE Register .....	39
<b>7. Application Information .....</b>	<b>40</b>
Connecting to Debug Adapter .....	40
7.1. Antenna Interface Circuitry .....	41
Single-Ended Antenna Interface .....	41
<b>8. QFN40 Package Information .....</b>	<b>42</b>



8.1. Package Outline QFN40 .....	42
8.2. QFN40 Soldering Profile.....	43
8.3. QFN40 Recommended Pad Layout.....	44
8.4. Assembly Process .....	44
Stencil Design & Solder Paste Application.....	44
<b>9. Device Versions.....</b>	<b>46</b>



## 1. Overview

### 1.1. Features

SoC Ultra-low power RF-microcontroller for wireless communication applications

- QFN40 package
- Supply range 2.2V - 3.6V (1.8V MCU)
- -40°C to 85°C
- Ultra-low power consumption:
  - CPU active mode 150  $\mu$ A/MHz
  - Sleep mode with 256 Byte RAM retention and wake-up timer running 900 nA
  - Sleep mode 4 kByte RAM retention and wake-up timer running 1.9  $\mu$ A
  - Sleep mode 8 kByte RAM retention and wake-up timer running 2.6  $\mu$ A
  - Radio TX-mode 22 mA at 10 dBm output power
- AX8052 features
  - Ultra-low power MCU core compatible with industry standard 8052 instruction set
  - Down to 250 nA wake-up current
  - 1 cycle/instruction for many instructions
  - 64 kByte in-system programmable FLASH
  - Code protection lock
  - 8.25 kByte SRAM
  - 3-wire (1 dedicated, 2 shared) in-circuit debug interface
  - 3 16-bit timers with  $\Sigma\Delta$  output capability
  - 2 16-bit wakeup timers
  - 2 input captures
- 2 output compares with PWM capability
- 10-bit 500 ksample/s analog-to-digital converter
- Temperature sensor
- 2 analog comparators
- 2 UARTs
- 1 general purpose master/slave SPI
- 2 channel DMA controller
- Multi-megabit/s AES encryption/decryption engine with True Random Number Generator (TRNG), supports AES-128, AES-192 and AES-256<sup>1</sup>
- Ultra-low power 10 kHz/640 Hz wakeup oscillator, with automatic calibration against a precise clock
- Internal 20 MHz RC oscillator, with automatic calibration against a precise clock for flexible system clocking
- Low frequency tuning fork crystal oscillator for accurate low power time keeping
- Brown-out and power-on-reset detection

- High-performance RF transmitter compatible to AX5031
  - 400-470 MHz and 800-940 MHz SRD bands
  - -5 dBm to +15 dBm programmable output
  - 13 mA @ 0 dBm, 868 MHz
  - 22 mA @ 10 dBm, 868 MHz
  - 44 mA @ 15 dBm, 868 MHz
  - Wide variety of shaped modulations supported (ASK,

<sup>1</sup> The AES engine and the TRNG require software enabling and support.



- **PSK, OQPSK, MSK, FSK, GFSK, 4-FSK)**
- **Flexible shaping for the modulations**
- **Data rates**  
  - 1 to 350 kbps for FSK, MSK**
  - 1 to 2000 kbps for ASK**
  - 10 to 2000 kbps for PSK**
- **Fully integrated RF frequency synthesizer with ultra-fast settling time for low-power consumption**
- **RF carrier frequency and FSK deviation programmable in 1 Hz steps**
- **802.15.4 compatible**
- **Few external components**
- **Channel hopping up to 2000 hops/s**
- **Up to +16 dBm at 433 MHz programmable transmitter power amplifier for long range operation**
- **Crystal oscillator with programmable transconductance and programmable internal tuning capacitors for low cost crystals**
- **Differential antenna pins**
- **Dual frequency registers**
- **Internally generated coding for forward Viterbi error correction**
- **Software compatible to AX5031**

## 1.2. Applications

400-470 MHz and 800-940 MHz data transmission in the Short Range Devices (SRD) band.

- Suited for systems targeting compliance to EN 300 220 wide band, FCC part 15.247 and FCC part 15.249
- Suited for systems targeting compliance with Wireless M-Bus S/T Mode
- 802.15.4 compatible
- Telemetric applications, sensor readout
- Toys
- Wireless audio
- Automatic meter reading
- Automatic meter reading
- Wireless networks
- Remote keyless entry
- Access control
- Garage door openers
- Home automation
- Pointing devices and keyboards
- Active RFID



2. Block Diagram

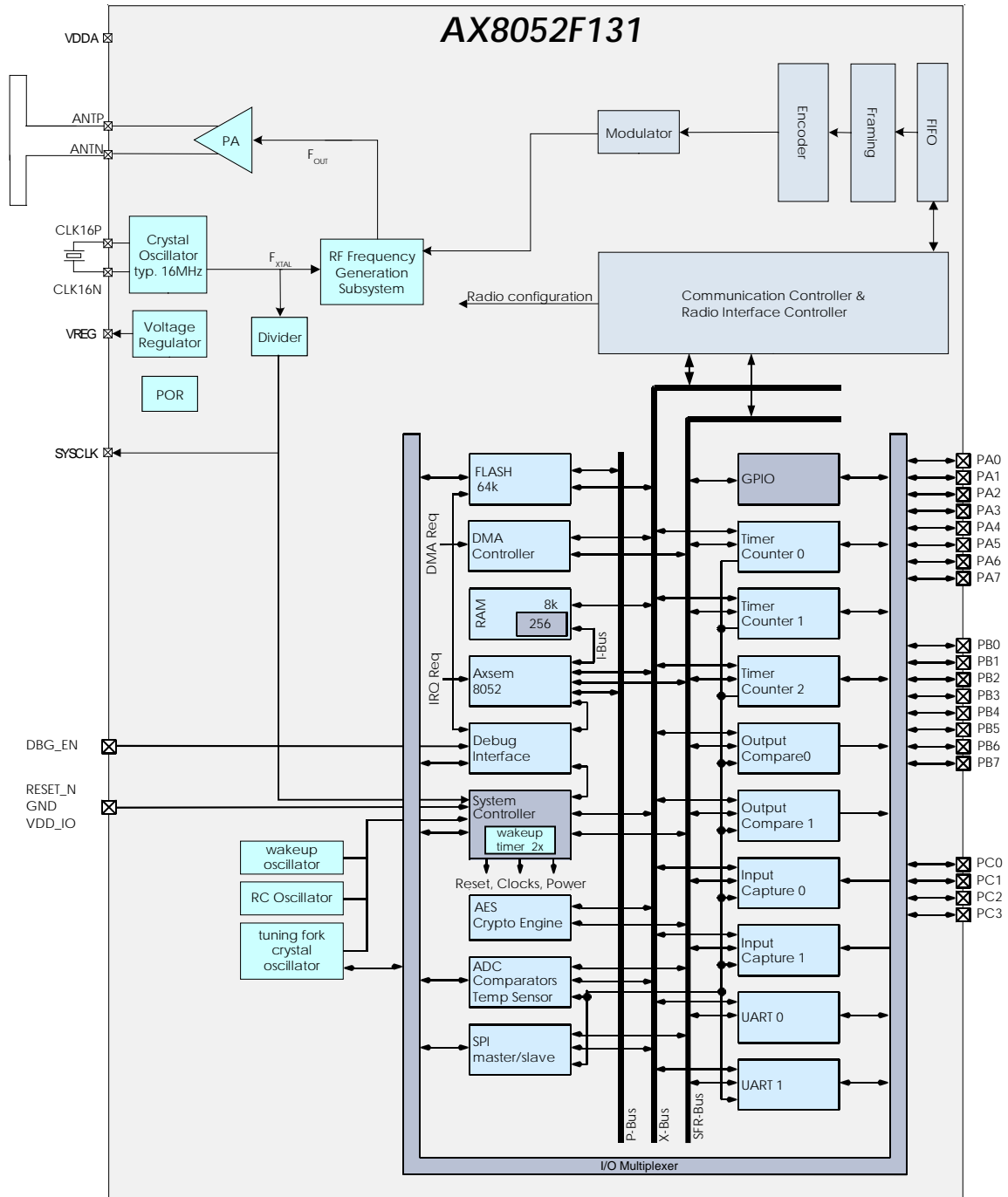

Figure 1 Functional block diagram of the AX8052F131



### 3. Pin Function Descriptions

Symbol	Pin(s)	Type	Description
CLK16P	1	A	Crystal oscillator input/output (RF reference)
CLK16N	2	A	Crystal oscillator input/output (RF reference)
VDDA	3	P	Power supply, must be supplied with regulated voltage VREG
GND	4	P	Ground
ANTP	5	A	Antenna output
ANTN	6	A	Antenna output
GND	7	P	Ground
VDDA	8	P	Power supply, must be supplied with regulated voltage VREG
SYSCLK	9	I/O/PU	Must be connected to SYSCLK at pin 13
T1	10	I/O/PU	Must be connected to T1 at pin 12
T2	11	I/O/PU	Must be left unconnected
T1	12	I/O/PU	Must be connected to T1 at pin 10
SYSCLK	13	I/O/PU	Must be connected to SYSCLK at pin 9
PC3	14	I/O/PU	General Purpose IO
PC2	15	I/O/PU	General Purpose IO
PC1	16	I/O/PU	General Purpose IO
PC0	17	I/O/PU	General Purpose IO
PB0	18	I/O/PU	General Purpose IO
PB1	19	I/O/PU	General Purpose IO
PB2	20	I/O/PU	General Purpose IO
PB3	21	I/O/PU	General Purpose IO
PB4	22	I/O/PU	General Purpose IO
PB5	23	I/O/PU	General Purpose IO
PB6	24	I/O/PU	General Purpose IO, DBG_DATA
PB7	25	I/O/PU	General Purpose IO, DBG_CLK
DBG_EN	26	I/PD	In-Circuit Debugger Enable
RESET_N	27	I/PU	Optional reset pin If this pin is not used it must be connected to VDD_IO
GND	28	P	Ground
VDD_IO	29	P	Unregulated power supply (battery input)
PA0	30	I/O/A/PU	General Purpose IO
PA1	31	I/O/A/PU	General Purpose IO
PA2	32	I/O/A/PU	General Purpose IO
PA3	33	I/O/A/PU	General Purpose IO
PA4	34	I/O/A/PU	General Purpose IO
PA5	35	I/O/A/PU	General Purpose IO
PA6	36	I/O/A/PU	General Purpose IO
PA7	37	I/O/A/PU	General Purpose IO





Symbol	Pin(s)	Type	Description
PC7	38	I/O/PU	General Purpose IO
VREG	39	P	Regulated output voltage VDDA pins must be connected to this supply voltage A 1µF low ESR capacitor to GND must be connected to this pin
GND	40	P	Ground
GND	Center pad	P	Ground on center pad of QFN, must be connected

A = analog signal

I = digital input signal

O = digital output signal

PU = pull-up

I/O = digital input/output signal

N = not to be connected

P = power or ground

PD = pull-down

All digital inputs are Schmitt trigger inputs, digital input and output levels are LVCMOS/LVTTL compatible. Port A Pins (PA0 - PA7) must not be driven above VDD\_IO, all other digital inputs are 5V tolerant. Pull-ups are programmable for all GPIO pins.

### 3.1. Alternate Pin Functions

GPIO Pins are shared with dedicated Input/Output signals of on-chip peripherals. The following table lists the available functions on each GPIO pin.

GPIO	Alternate Functions			
PA0	T0OUT	IC1	ADC0	
PA1	T0CLK	OC1	ADC1	
PA2	OC0	U1RX	ADC2	COMPI00
PA3	T1OUT		ADC3	LPXTALP
PA4	T1CLK	COMPO0	ADC4	LPXTALN
PA5	IC0	U1TX	ADC5	COMPI10
PA6	T2OUT	ADCTRIG	ADC6	COMPI01
PA7	T2CLK	COMPO1	ADC7	COMPI11
PB0	U1TX	IC1	EXTIRQ0	
PB1	U1RX	OC1		
PB2	IC0	T2OUT		
PB3	OC0	T2CLK	EXTIRQ1	DSWAKE
PB4	U0TX	T1CLK		
PB5	U0RX	T1OUT		
PB6	DBG_DATA			
PB7	DBG_CLK			
PC0	SSEL	T0OUT	EXTIRQ0	
PC1	SSCK	T0CLK	COMPO1	
PC2	SMOSI	U0TX		
PC3	SMISO	U0RX	COMPO0	
PC7	RPWRUP			



3.2. Pinout Drawing

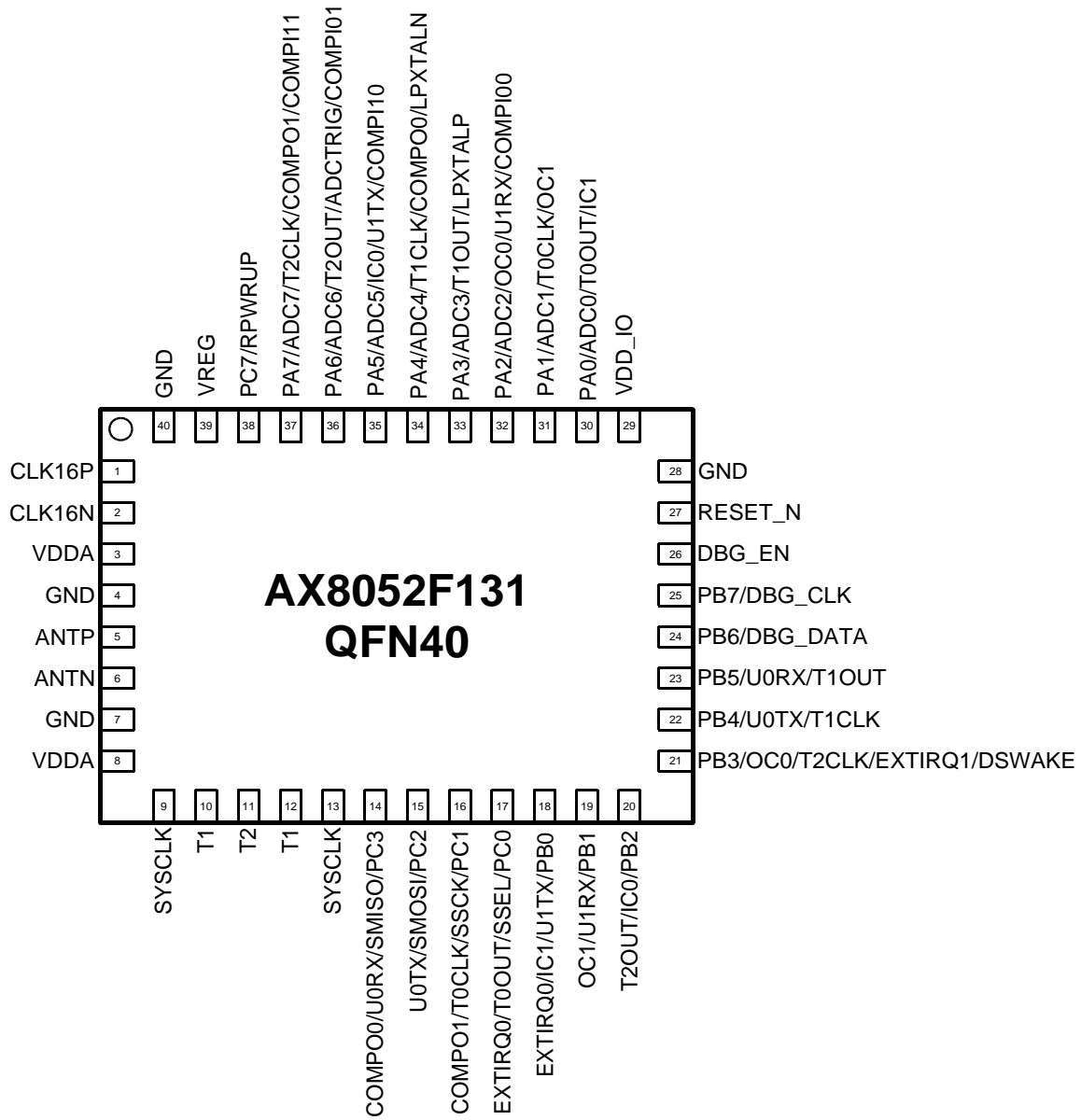

Figure 2 Pinout drawing (Top view)



## 4. Specifications

### 4.1. Absolute Maximum Ratings

Stresses above those listed under Absolute Maximum Ratings may cause permanent damage to the device.

This is a stress rating only; functional operation of the device at these or any other conditions above those listed in the operational sections of this specification is not implied.

Exposure to absolute maximum rating conditions for extended periods may affect device reliability.

SYMBOL	DESCRIPTION	CONDITION	MIN	MAX	UNIT
VDD_IO	Supply voltage		-0.5	5.5	V
IDD	Supply current			100	mA
P <sub>tot</sub>	Total power consumption			800	mW
I <sub>I1</sub>	DC current into any pin except ANTP, ANTN		-10	10	mA
I <sub>I2</sub>	DC current into pins ANTP, ANTN		-100	100	mA
I <sub>o</sub>	Output Current			40	mA
V <sub>ia</sub>	Input voltage ANTP, ANTN pins		-0.5	5.5	V
	Input voltage digital pins		-0.5	5.5	V
V <sub>es</sub>	Electrostatic handling	HBM	-2000	2000	V
T <sub>amb</sub>	Operating temperature		-40	85	°C
T <sub>stg</sub>	Storage temperature		-65	150	°C
T <sub>j</sub>	Junction Temperature			150	°C



## 4.2. DC Characteristics

## Supplies

SYMBOL	DESCRIPTION	CONDITION	MIN	TYP	MAX	UNIT
$T_{AMB}$	Operational ambient temperature		-40	27	85	°C
VDD_IO	I/O and voltage regulator supply voltage	TX operation	2.2	3.0	3.6	V
		Transmitter switched off	1.8	3.0	3.6	V
VDD <sub>IO_R1</sub>	I/O voltage ramp for reset activation; Note 1	Ramp starts at VDD_IO ≤ 0.1V	0.1			V/ms
VDD <sub>IO_R2</sub>	I/O voltage ramp for reset activation; Note 1	Ramp starts at 0.1V < VDD_IO < 0.7V	3.3			V/ms
VREG	Internally regulated analog supply voltage	Power-down mode AX5031_PWRMODE=0x00		1.7		V
		All other power modes	2.1	2.5	2.8	V
I <sub>DEEPSLEEP</sub>	Deep Sleep current			250		nA
I <sub>SLEEP256PIN</sub>	Sleep current, 256 Bytes RAM retained	Wakeup from dedicated pin		700		nA
I <sub>SLEEP256</sub>	Sleep current, 256 Bytes RAM retained	Wakeup Timer running at 640Hz		1.1		μA
I <sub>SLEEP4K</sub>	Sleep current, 4.25 kBytes RAM retained	Wakeup Timer running at 640Hz		1.7		μA
I <sub>SLEEP8K</sub>	Sleep current, 8.25 kBytes RAM retained	Wakeup Timer running at 640Hz		2.4		μA
I <sub>TX</sub>	Current consumption TX for maximum power with default matching network at 3.3V VDD_IO, note 2	868 MHz, 15 dBm		22		mA
		868 MHz, 0 dBm		13		
		868 MHz, 15 dBm		45		
		433 MHz, 10 dBm		22		
		433 MHz, 0 dBm		13		
		433 MHz, 15 dBm		45		
TX <sub>varvdd</sub>	Variation of output power over voltage	VDD_IO > 2.5V, note 2		+/- 0.5		dB
TX <sub>vartemp</sub>	Variation of output power over temperature	VDD_IO > 2.5V, note 2		+/- 0.5		dB
I <sub>MCU</sub>	Microcontroller running power consumption	All peripherals disabled		150		μA/ MHz
I <sub>VSUP</sub>	Voltage supervisor	Run and standby mode		85		μA
I <sub>XTALOSC</sub>	Crystal oscillator current (RF reference oscillator)	16 MHz		160		μA
I <sub>LFXTALOSC</sub>	Low frequency crystal oscillator current	32 kHz		700		nA
I <sub>RCOSC</sub>	Internal oscillator current	20 MHz		210		μA
I <sub>LPOSC</sub>	Internal Low Power Oscillator current	10 kHz		650		nA
		640 Hz		210		nA
I <sub>ADC</sub>	ADC current	311 kSample/s, DMA 5 MHz		1.1		mA

## Notes:

1. If VDD\_IO ramps cannot be guaranteed, an external reset circuit is recommended, see the AX8052 Application Note: Power On Reset
2. The PA voltage is regulated to 2.5 V. For VDD\_IO levels in the range of 2.2 V to 2.55 V the output power drops by typically 1 dBm.



### Note on current consumption in TX mode

To achieve best output power the matching network has to be optimized for the desired output power and frequency. As a rule of thumb a good matching network produces about 50% efficiency with the **AX8052F131** power amplifier although over 90% are theoretically possible. A typical matching network has between 1 dB and 2 dB loss ( $P_{\text{loss}}$ ).

The current consumption can be calculated as

$$I_{\text{TX}}[\text{mA}] = 1/P_{\text{efficiency}} * 10^{((P_{\text{out}}[\text{dBm}] + P_{\text{loss}}[\text{dB}])/10)/2.5V} + I_{\text{offset}}$$

$I_{\text{offset}}$  is about 12 mA for the VCO at 400-470 MHz and 11 mA for 800-940 MHz. The following table shows calculated current consumptions versus output power for  $P_{\text{loss}} = 1 \text{ dB}$ ,  $P_{\text{efficiency}} = 0.5$  and  $I_{\text{offset}} = 11 \text{ mA}$  at 868 MHz

Pout [dBm]	I [mA]
0	13.0
1	13.2
2	13.6
3	14.0
4	14.5
5	15.1
6	16.0
7	17.0
8	18.3
9	20.0
10	22.0
11	24.6
12	27.96
13	32.1
14	37.3
15	43.8

The **AX8052F131** power amplifier runs from the regulated VDD supply and not directly from the battery. This has the advantage that the current and output power do not vary much over supply voltage and temperature from 2.55 V to 3.6 V supply voltage. Between 2.55 V and 2.2 V a drop of about 1 dB in output power occurs.



## Logic

SYMBOL	DESCRIPTION	CONDITION	MIN	TYP	MAX	UNIT
<b>DIGITAL INPUTS</b>						
$V_{T+}$	Schmitt trigger low to high threshold point	$V_{DD\_IO} = 3.3V$		1.55		V
$V_{T-}$	Schmitt trigger high to low threshold point			1.25		V
$V_{IL}$	Input voltage, low				0.8	V
$V_{IH}$	Input voltage, high		2.0			V
$V_{IPA}$	Input voltage range, Port A		-0.5		$V_{DD\_IO}$	V
$V_{IPBC}$	Input voltage range, Ports B, C		-0.5		5.5	V
$I_L$	Input leakage current		-10		10	$\mu A$
$R_{PU}$	Programmable Pull-Up Resistance			65		$k\Omega$
<b>DIGITAL OUTPUTS</b>						
$I_{OH}$	P[ABC]x Output Current, high	$V_{OH} = 2.4V$	8			mA
$I_{OL}$	P[ABC]x Output Current, low	$V_{OL} = 0.4V$	8			mA
$I_{PROH}$	SYSCLK Output Current, high	$V_{OH} = 2.4V$	8			mA
$I_{PROL}$	SYSCLK Output Current, low	$V_{OL} = 0.4V$	8			mA
$I_{OZ}$	Tri-state output leakage current		-10		10	$\mu A$



4.3. AC Characteristics

Crystal Oscillator (RF reference oscillator)

SYMBOL	DESCRIPTION	CONDITION	MIN	TYP	MAX	UNIT
f <sub>XTAL</sub>	Crystal frequency	Note 1, 3	15.5	16	25	MHz
gm <sub>osc</sub>	Transconductance oscillator	AX5031_XTALOSCGM=0000		1		mS
		AX5031_XTALOSCGM=0001		2		
		AX5031_XTALOSCGM =0010 default		3		
		AX5031_XTALOSCGM =0011		4		
		AX5031_XTALOSCGM =0100		5		
		AX5031_XTALOSCGM =0101		6		
		AX5031_XTALOSCGM =0110		6.5		
		AX5031_XTALOSCGM =0111		7		
		AX5031_XTALOSCGM =1000		7.5		
		AX5031_XTALOSCGM =1001		8		
		AX5031_XTALOSCGM =1010		8.5		
		AX5031_XTALOSCGM =1011		9		
		AX5031_XTALOSCGM =1100		9.5		
		AX5031_XTALOSCGM =1101		10		
AX5031_XTALOSCGM =1110		10.5				
AX5031_XTALOSCGM =1111		11				
C <sub>osc</sub>	Programmable tuning capacitors at pins CLK16N and CLK16P	AX5031_XTALCAP=000000 default		2		pF
		AX5031_XTALCAP=111111		33		pF
C <sub>osc-lsb</sub>	Programmable tuning capacitors, increment per LSB of AX5031_XTALCAP			0.5		pF
f <sub>ext</sub>	External clock input (TCXO)	Note 2, 3	15.5	16	25	MHz
A <sub>osc</sub>	Oscillator amplitude at pin CLK16P				0.5	V
RIN <sub>osc</sub>	Input DC impedance		10			kΩ

Notes

1. Tolerances and start-up times depend on the crystal used. Depending on the RF frequency and channel spacing the IC must be calibrated to the exact crystal frequency using the readings of the register AX5031\_TRKFREQ
2. If an external clock is used, it should be input via an AC coupling at pin CLK16P with the oscillator powered up and AX5031\_XTALCAP=000000
3. Lower frequencies than 15.5 MHz or higher frequencies than 25 MHz can be used. However not all typical RF frequencies can than be generated.



## RF Frequency Generation Subsystem (Synthesizer)

SYMBOL	DESCRIPTION	CONDITION	MIN	TYP	MAX	UNIT
$f_{REF}$	Reference frequency	Note 1		16 24		MHz
$f_{range\_hi}$	Frequency range	BANDSEL=0	800		940	MHz
$f_{range\_low}$		BANDSEL=1	400		470	
$f_{RESO}$	Frequency resolution		1			Hz
$BW_1$	Synthesizer loop bandwidth  VCO current: VCOI=001	Loop filter configuration: FLT=01 Charge pump current: PLLCPI=010		100		kHz
$BW_2$		Loop filter configuration: FLT=01 Charge pump current: PLLCPI=001		50		
$BW_3$		Loop filter configuration: FLT=11 Charge pump current: PLLCPI=010		200		
$BW_4$		Loop filter configuration: FLT=10 Charge pump current: PLLCPI=010		500		
$T_{set1}$	Synthesizer settling time for 1MHz step  VCO current: VCO_I=001	Loop filter configuration: FLT=01 Charge pump current: PLLCPI=010		15		$\mu$ s
$T_{set2}$		Loop filter configuration: FLT=01 Charge pump current: PLLCPI=001		30		
$T_{set3}$		Loop filter configuration: FLT=11 Charge pump current: PLLCPI=010		7		
$T_{set4}$		Loop filter configuration: FLT=10 Charge pump current: PLLCPI=010		3		
$T_{start1}$	Synthesizer start-up time if crystal oscillator and reference are running  VCO current: VCO_I=001	Loop filter configuration: FLT=01 Charge pump current: PLLCPI=010		25		$\mu$ s
$T_{start2}$		Loop filter configuration: FLT=01 Charge pump current: PLLCPI=001		50		
$T_{start3}$		Loop filter configuration: FLT=11 Charge pump current: PLLCPI=010		12		





T <sub>start4</sub>		Loop filter configuration: FLT=10 Charge pump current: PLLCPI=010		5			
PN868 <sub>1</sub>	Synthesizer phase noise Loop filter configuration: FLT=01	868 MHz, 50 kHz from carrier		-85		dBc/Hz	
		868 MHz, 100 kHz from carrier		-90			
		868 MHz, 300 kHz from carrier		-100			
		868 MHz, 2 MHz from carrier		-110			
PN433 <sub>1</sub>	Charge pump current: PLLCPI=010 VCO current: VCO_I=001	433 MHz, 50 kHz from carrier		-90			
		433 MHz, 100 kHz from carrier		-95			
		433 MHz, 300 kHz from carrier		-105			
		433 MHz, 2 MHz from carrier		-115			
PN868 <sub>2</sub>	Synthesizer phase noise Loop filter configuration: FLT=01	868 MHz, 50 kHz from carrier		-80			dBc/Hz
		868 MHz, 100 kHz from carrier		-90			
		868 MHz, 300 kHz from carrier		-105			
		868 MHz, 2 MHz from carrier		-115			
PN433 <sub>2</sub>	Charge pump current: PLLCPI=001 VCO current: VCO_I=001	433 MHz, 50 kHz from carrier		-90			
		433 MHz, 100 kHz from carrier		-95			
		433 MHz, 300 kHz from carrier		-110			
		433 MHz, 2 MHz from carrier		-122			

Notes:

1. ASK, PSK and 1-200 kbps FSK with 16 MHz crystal, 200-350 kbps FSK with 24 MHz crystal



## Transmitter

SYMBOL	DESCRIPTION	CONDITION	MIN	TYP	MAX	UNIT
SBR	Signal bit rate	ASK	1		2000	kbps
		PSK	10		2000	
		FSK, note 2	1		350	
		802.15.4 (DSSS) ASK and PSK	1		40	
		802.15.4 (DSSS) FSK	1		16	
PTX <sub>868</sub>	Transmitter power @868 MHz	TXRNG=1111		15		dBm
PTX <sub>433</sub>	Transmitter power @433 MHz	TXRNG=1111		16		dBm
PTX <sub>868-harm2</sub>	Emission @ 2 <sup>nd</sup> harmonic	Note 1		-50		dBc
PTX <sub>868-harm3</sub>	Emission @ 3 <sup>rd</sup> harmonic			-55		

### Notes

1. Additional low-pass filtering was applied to the antenna interface, see applications section.
2. 1-200 kbps with a 16 MHz crystal, 200-350 kbps with a 24 MHz crystal



## Low Frequency Crystal Oscillator

SYMBOL	DESCRIPTION	CONDITION	MIN	TYP	MAX	UNIT
$f_{LPXTAL}$	Crystal frequency			32	150	kHz
$gm_{I_{pXOSC}}$	Transconductance oscillator	LXOSCGM=00110		3.5		$\mu S$
		LXOSCGM=01000		4.6		
		LXOSCGM=01100		6.9		
		LXOSCGM=10000		9.1		
$RIN_{I_{pXOSC}}$	Input DC impedance		10			$M\Omega$

## Internal Low Power Oscillator

SYMBOL	DESCRIPTION	CONDITION	MIN	TYP	MAX	UNIT
$f_{LPOSC}$	Oscillation Frequency	LPOSCFAST=0 Factory calibration applied. Over the full voltage and temperature range	630	640	650	Hz
		LPOSCFAST=1 Factory calibration applied. Over the full voltage and temperature range	10.08	10.24	10.39	kHz

## Internal RC Oscillator

SYMBOL	DESCRIPTION	CONDITION	MIN	TYP	MAX	UNIT
$F_{FRCOSC}$	Oscillation Frequency	Factory calibration applied. Over the full temperature and voltage range	19.8	20	20.2	MHz



Microcontroller

SYMBOL	DESCRIPTION	CONDITION	MIN	TYP	MAX	UNIT
T <sub>SYCLKL</sub>	SYCLK Low		27			ns
T <sub>SYCLKH</sub>	SYCLK High		21			ns
T <sub>SYCLKP</sub>	SYCLK Period		47			ns
T <sub>FLWR</sub>	FLASH Write Time	2 Bytes		20		μs
T <sub>FLPE</sub>	FLASH Page Erase	1 kBytes		2		ms
T <sub>FLE</sub>	FLASH Secure Erase	64 kBytes		10		ms
T <sub>FLEND</sub>	FLASH Endurance: Erase Cycles		10'000	100'000		Cycles
T <sub>FLRERoom</sub>	FLASH Data Retention	25°C See Figure 3 for the lower limit set by the memory qualification		100		Years
T <sub>FLREHot</sub>		85°C See Figure 3 for the lower limit set by the memory qualification		10		

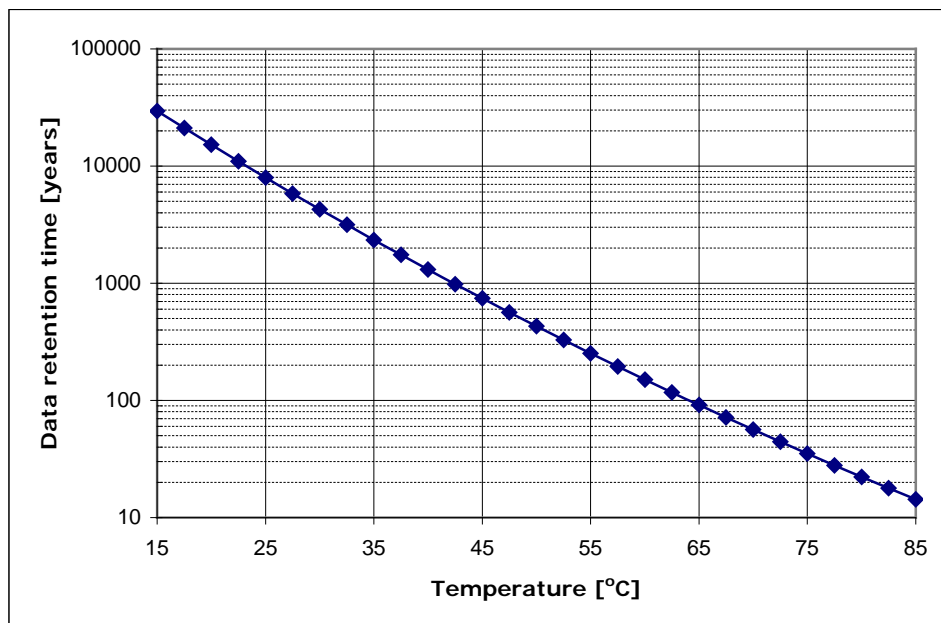

Figure 3 FLASH memory qualification limit for data retention after 10k erase cycles



## ADC / Comparator / Temperature Sensor

SYMBOL	DESCRIPTION	CONDITION	MIN	TYP	MAX	UNIT
ADCSR	ADC sampling rate GPADC mode		30		500	kHz
ADCSR_T	ADC sampling rate temperature sensor mode		10	15.6	30	kHz
ADCRES	ADC resolution			10		Bits
V <sub>ADCREf</sub>	ADC reference voltage & comparator internal reference voltage		0.95	1	1.05	V
Z <sub>ADC00</sub>	Input capacitance				2.5	pF
DNL	Differential nonlinearity				+/- 1	LSB
INL	Integral nonlinearity			+/- 1		LSB
OFF	Offset			3		LSB
GAIN_ERR	Gain error			0.8		%
<b>ADC in Differential Mode</b>						
V <sub>ABS_DIFF</sub>	Absolute voltages & common mode voltage in differential mode at each input		0		VDD_IO	V
V <sub>FS_DIFF01</sub>	Full swing input for differential signals	Gain x1	-500		500	mV
V <sub>FS_DIFF10</sub>		Gain x10	-50		50	mV
<b>ADC in Single Ended Mode</b>						
V <sub>MID_SE</sub>	Mid code input voltage in single ended mode			0.5		V
V <sub>IN_SE00</sub>	Input voltage in single ended mode		0		VDD_IO	V
V <sub>FS_SE01</sub>	Full swing input for single ended signals	Gain x1	0		1	V
<b>Comparators</b>						
V <sub>COMP_ABS</sub>	Comparator absolute input voltage		0		VDD_IO	V
V <sub>COMP_COM</sub>	Comparator input common mode		0		VDD_IO-0.8	V
V <sub>COMPOFF</sub>	Comparator input offset voltage				20	mV
<b>Temperature Sensor</b>						
T <sub>RNG</sub>	Temperature range		-40		85	°C
T <sub>RES</sub>	Temperature resolution			0.1607		°C/LSB
T <sub>ERR_CAL</sub>	Temperature error	Factory calibration applied	-2		+2	°C



## 5. Circuit Description

The **AX8052F131** is a single chip ultra-low-power RF-microcontroller SoC primarily for use in SRD bands. The on-chip transmitter consists of a fully integrated RF front-end with modulator, and demodulator. Base band data processing is implemented in an advanced and flexible communication controller that enables user friendly communication.

The **AX8052F131** contains a high speed microcontroller compatible to the industry standard 8052 instruction set. It contains 64 kBytes of FLASH and 8.25 kBytes of internal SRAM.

The **AX8052F131** features 3 16-bit general purpose timers with  $\Sigma\Delta$  capability, 2 output compare units for generating PWM signals, 2 input compare units to record timings of external signals, 2 16-bit wakeup timers, a watchdog timer, 2 UARTs, a Master/Slave SPI controller, a 10-bit 500 kSample/s A/D converter, 2 analog comparators, a temperature sensor, a 2 channel DMA controller, and a dedicated AES crypto controller. Debugging is aided by a dedicated hardware debug interface controller that connects using a 3-wire protocol (1 dedicated wire, 2 shared with GPIO) to the PC hosting the debug software.

While the radio carrier can only be clocked by the crystal oscillator (carrier stability requirements dictate a high stability reference clock in the MHz range), the microcontroller and its peripherals provide extremely flexible clocking options. The system clock that clocks the microcontroller, as well as peripheral clocks, can be selected from one of the following clock sources: the crystal oscillator, an internal high speed 20 MHz oscillator, an internal low speed 640 Hz/10 kHz oscillator, or the low frequency crystal oscillator. Prescalers offer additional flexibility with their programmable divide by a power of two capability. To improve the accuracy of the internal oscillators, both oscillators may be slaved to the crystal oscillator.

**AX8052F131** can be operated from a 2.2 V to 3.6 V power supply over a temperature range of  $-40^{\circ}\text{C}$  to  $85^{\circ}\text{C}$ , it consumes 11 - 45 mA for transmitting, depending on the output power.

The **AX8052F131** features make it an ideal interface for integration into various battery powered SRD solutions such as ticketing or as transmitter for telemetric applications e.g. in sensors. As primary application, the transmitter is intended for UHF radio equipment in accordance with the European Telecommunication Standard Institute (ETSI) specification EN 300 220-1 and the US Federal Communications Commission (FCC) standard CFR47, part 15. The use of **AX8052F131** in accordance to FCC Par 15.247, allows for improved range in the 915 MHz band. Additionally **AX8052F131** is compatible with the low frequency standards of 802.15.4 (ZigBee) and suited for systems targeting compliance with Wireless M-Bus standard EN 13757-4:2005

The **AX8052F131** sends data in frames. This standard operation mode is called Frame Mode. Pre and post ambles as well as checksums can be generated automatically.

**AX8052F131** supports any data rate from 1 kbps to 350 kbps for FSK and MSK, from 1 kbps to 2000 kbps for ASK and from 10 kbps to 2000 kbps for PSK. To achieve optimum performance for specific data rates and modulation schemes several register settings to configure the **AX8052F131** are necessary, they are outlined in the following, for details see the AX5031 Programming Manual.

Spreading is possible on all data rates and modulation schemes. The net transfer rate is reduced by a factor of 15 in this case. For ZigBee either 600 or 300 kbps modes have to be chosen.

The transmitter supports multi-channel operation for all data rates and modulation schemes.

## 5.1. Microcontroller

The **AX8052F131** microcontroller core executes the industry standard 8052 instruction set. Unlike the original 8052, many instructions are executed in a single cycle. The system clock and thus the instruction rate can be programmed freely from DC to 20MHz.

### Memory Architecture

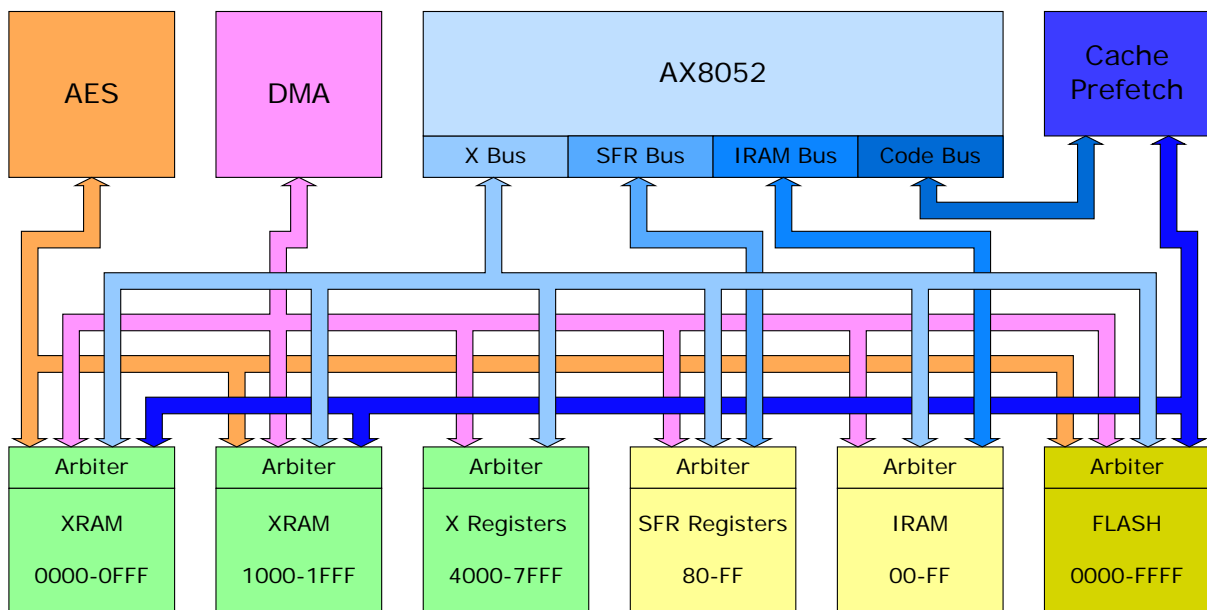

Figure 4 AX8052 Memory Architecture

The AX8052 Microcontroller features the highest bandwidth memory architecture of its class. Figure 4 shows the memory architecture. Three bus masters may initiate bus cycles:

- The AX8052 Microcontroller Core
- The Direct Memory Access (DMA) Engine
- The Advanced Encryption Standard (AES) Engine

Bus targets include:

- Two individual 4 kBytes RAM blocks located in X address space, which can be simultaneously accessed and individually shut down or retained during sleep mode
- A 256 Byte RAM located in internal address space, which is always retained during sleep mode
- A 64 kBytes FLASH memory located in code space.
- Special Function Registers (SFR) located in internal address space accessible using direct address mode instructions
- Additional Registers located in X address space (X Registers)



The upper half of the FLASH memory may also be accessed through the X address space. This simplifies and makes the software more efficient by reducing the need for generic pointers<sup>2</sup>.

SFR Registers are also accessible through X address space, enabling indirect access to SFR registers. This allows driver code for multiple identical peripherals (such as UARTs or Timers) to be shared.

The 4 word × 16 bit fully associative cache and a pre-fetch controller hide the latency of the FLASH.

The AX8052 Memory Architecture is fully parallel. All bus masters may simultaneously access different bus targets during each system clock cycle. Each bus target includes an arbiter that resolves access conflicts. Each arbiter ensures that no bus master can be starved.

Both 4 kBytes RAM blocks may be individually retained or switched off during sleep mode. The 256 Byte RAM is always retained during sleep mode.

The AES engine accesses memory 16bits at a time. It is therefore slightly faster to align its buffers on even addresses.

## Memory Map

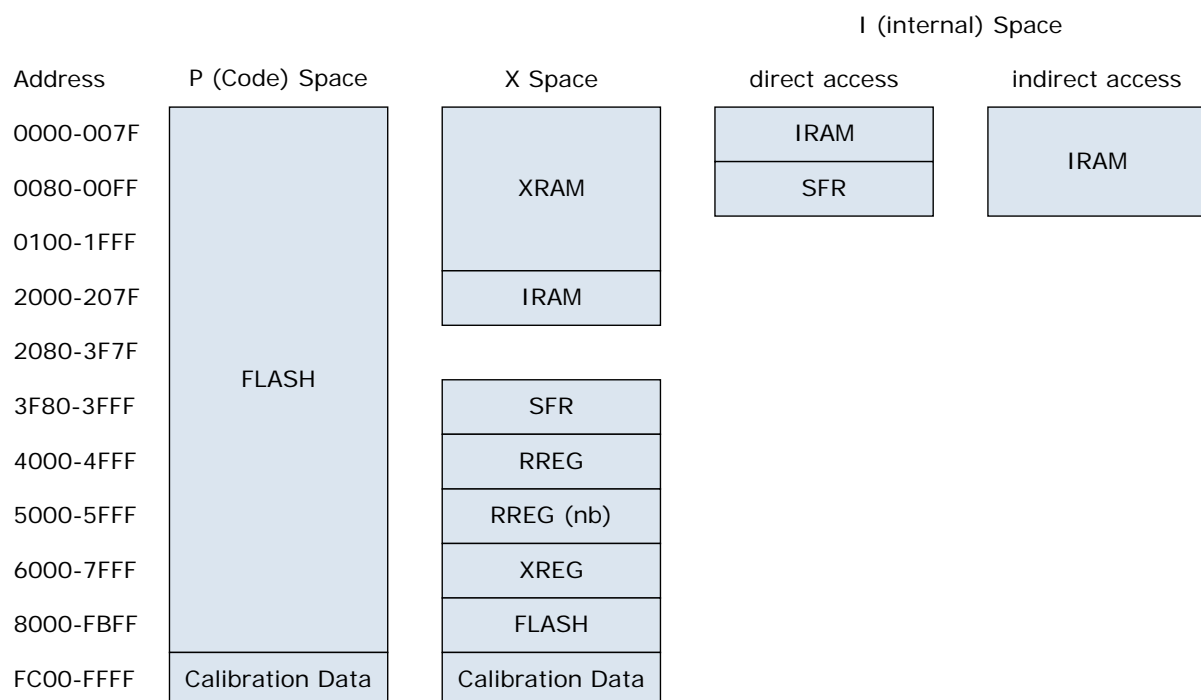

Figure 5 AX8052 Memory Map

The AX8052, like the other industry standard 8052 compatible microcontrollers, uses a Harvard architecture. Multiple address spaces are used to access code and data. Figure 5 shows the AX8052 memory map.

<sup>2</sup> Generic pointers include, in addition to the address, an address space tag.





The AX8052 uses P or Code Space to access its program. Code space may also be read using the MOV<sub>C</sub> instruction.

Smaller amounts of data can be placed in the Internal<sup>3</sup> or Data Space. A distinction is made in the upper half of the Data Space between direct accesses (MOV reg,addr; MOV addr,reg) and indirect accesses (MOV reg,@Ri; MOV @Ri,reg; PUSH; POP); Direct accesses are routed to the Special Function Registers, while indirect accesses are routed to the internal RAM.

Large amounts of data can be placed in the External or X Space. It can be accessed using the MOV<sub>X</sub> instructions. Special Function Registers, as well as additional Microcontroller Registers (XREG) and the Radio Registers (RREG) are also mapped into the X Space.

Detailed documentation of the Special Function Registers (SFR) and additional Microcontroller Registers can be found in the AX8052 Programming Manual.

The Radio Registers are documented in the AX5031 Programming Manual. Register Addresses given in the AX5031 Programming Manual are relative to the beginning of RREG, i.e. 0x4000 must be added to these addresses. It is recommended that the Axsem provided ax8052f131.h header file is used; Radio Registers are prefixed with AX5031\_ in the ax8052f131.h header file to avoid clashes of same-name Radio registers with AX8052 registers.

Normally, accessing Radio Registers through the RREG address range is adequate. Since Radio Register accesses have a higher latency than other AX8052 registers, the AX8052 provides a method for non-blocking access to the Radio Registers. Accessing the RREG (nb) address range initiates a Radio Register access, but does not wait for its completion. The details of mechanism is documented in the Radio Interface section of the AX8052 Programming Manual.

The FLASH memory is organized as 64 pages of 1 kBytes each. Each page can be individually erased. The write word size is 16 Bits. The last 1 kByte page is dedicated to factory calibration data and should not be overwritten.

## Power Management

The microcontroller power mode can be selected independently from the transmitter. The microcontroller supports the following power modes:

<i>PCON</i> register	Name	Description
00	RUNNING	The microcontroller and all peripherals are running. Current consumption depends on the system clock frequency and the enabled peripherals and their clock frequency.
01	STANDBY	The microcontroller is stopped. All register and memory contents are retained. All peripherals continue to function normally. Current consumption is determined by the enabled peripherals. STANDBY is exited when any of the enabled interrupts become active.
10	SLEEP	The microcontroller and its peripherals, except GPIO and the system controller, are shut down. Their register settings are lost. The internal RAM is retained. The external RAM is split into two 4kByte blocks. Software can determine individually for both blocks whether contents of that block are to be retained or lost. SLEEP can be exited

<sup>3</sup> The origin of Internal versus External (X) Space is historical. External Space used to be outside of the chip on the original 8052 Microcontrollers.



		by any of the enabled GPIO or system controller interrupts. For most applications this will be a GPIO or wakeup timer interrupt.
11	DEEPSLEEP	The microcontroller, all peripherals and the transmitter are shut down. Only 4 bytes of scratch RAM are retained. DEEPSLEEP can only be exited by tying the PB3 pin low.

## Clocking

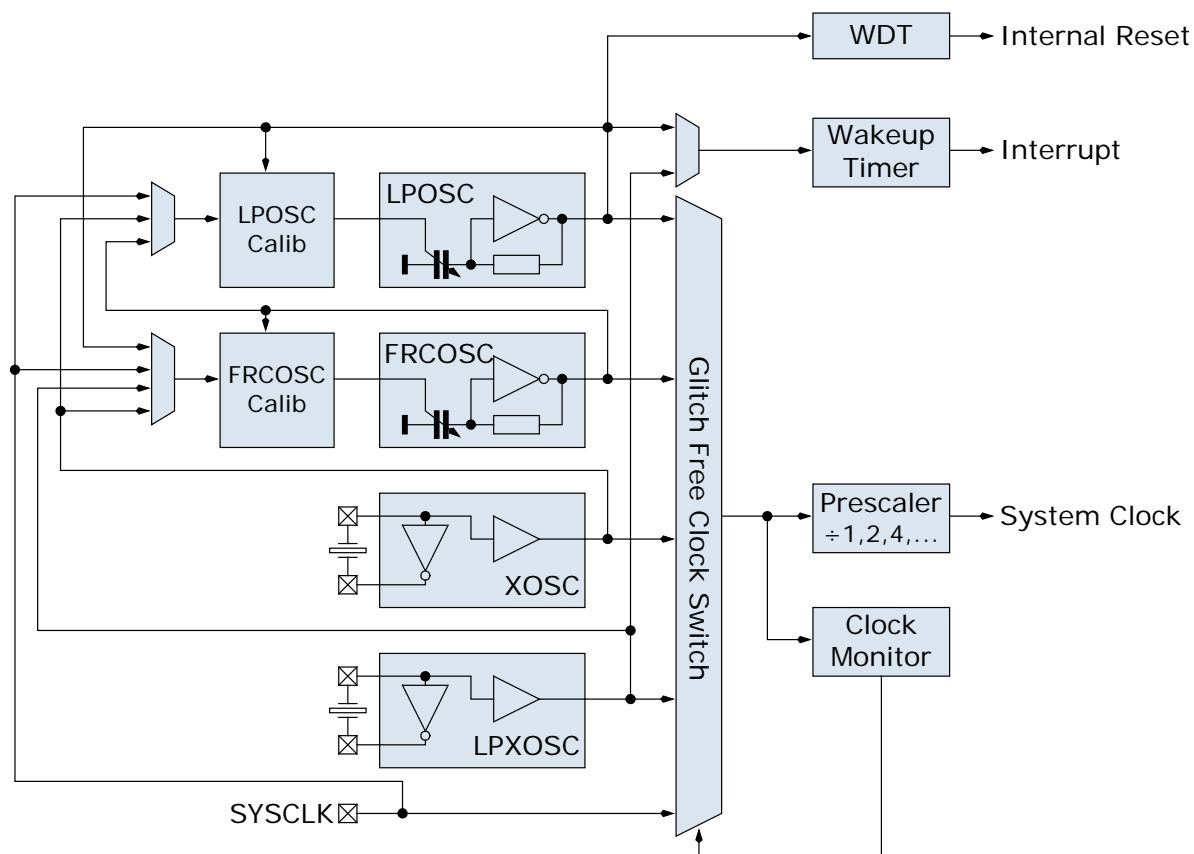

Figure 6 Clock System Diagram

The system clock can be derived from any of the following clock sources:

- The crystal oscillator (RF reference oscillator, typically 16 MHz, via SYSCLK)
- The low speed crystal oscillator (typical 32 kHz tuning fork)
- The internal high speed RC (20 MHz) oscillator
- The internal low power (640 Hz/10 kHz) oscillator

An additional pre-scaler allows the selected oscillator to be divided by a power of two. After reset, the microcontroller starts with the internal high speed RC oscillator selected and divided by two. I.e. at start-up, the microcontroller runs with 10 MHz  $\pm$  10%. Clocks may be switched any time by writing to the CLKCON register. In order to prevent clock glitches, the switching takes approximately  $2 \cdot (T_1 + T_2)$ , where  $T_1$  and  $T_2$  are the periods of the old and the new clock. Switching



may take longer if the new oscillator first has to start up. Internal oscillators start up instantaneously, but crystal oscillators may take a considerable amount of time to start the oscillation. **CLKSTAT** can be read to determine the clock switching status.

A programmable clock monitor resets the **CLKCON** register when no system clock transitions are found during a programmable time interval, thus reverts to the internal RC oscillator.

Both internal oscillators can be slaved to one of the crystal oscillators to increase the accuracy of the oscillation frequency. While the reference oscillator runs, the internal oscillator is slaved to the reference frequency by a digital frequency locked loop. When the reference oscillator is switched off, the internal oscillator continues to run unslaved with the last frequency setting.

## Reset and Interrupts

---

After reset, the microcontroller starts executing at address 0x0000. Several events can lead to resetting the microcontroller core:

- POR or hardware RESET\_N pin activated and released
- Leaving SLEEP or DEEPSLEEP mode
- Watchdog Reset
- Software Reset

The reset cause can be determined by reading the **PCON** register.

The microcontroller supports 22 interrupt sources. Each interrupt can be individually enabled and can be programmed to have one of two possible priorities. The interrupt vectors are located at 0x0003, 0x000B, ..., 0x00AB.

## Debugging

---

A hardware debug unit considerably eases debugging compared to other 8052 microcontrollers. It allows to reliably stop the microcontroller at breakpoints even if the stack is smashed. The debug unit communicates with the host PC running the debugger using a 3 wire interface. One wire is dedicated (DBG\_EN), while two wires are shared with GPIO pins (PB6, PB7). When DBG\_EN is driven high, PB6 and PB7 convert to debug interface pins and the GPIO functionality is no longer available. A pin emulation feature however allows bits PINB[7:6] to be set and PORTB[7:6] and DIRB[7:6] to be read by the debugger software. This allows for example switches or LEDs connected to the PB6, PB7 pins to be emulated in the debugger software whenever the debugger is active.

In order to protect the intellectual property of the firmware developer, the debug interface can be locked using a developer-selectable 64-bit key. The debug interface is then disabled and can only be enabled with the knowledge of this 64-bit key. Therefore, unauthorized persons cannot read the firmware through the debug interface, but debugging is still possible for authorized persons. Secure erase can be initiated without key knowledge; secure erase ensures that the main FLASH array is completely erased before erasing the key, reverting the chip into factory state.

The DebugLink peripheral looks like an UART to the microcontroller, and allows exchange of data between the microcontroller and the host PC without disrupting program execution.



## 5.2. Timer, Output Compare and Input Capture

The **AX8052F131** features three general purpose 16-bit timers. Each timer can be clocked by the system clock, any of the available oscillators, or a dedicated input pin. The timers also feature a programmable clock inversion, a programmable prescaler that can divide by powers of two, and an optional clock synchronization logic that synchronizes the clock to the system clock. All three counters are identical and feature four different counting modes, as well as a  $\Sigma\Delta$  mode that can be used to output an analog value on a dedicated digital pin only employing a simple RC lowpass filter.

Two output compare units work in conjunction with one of the timers to generate PWM signals.

Two input capture units work in conjunction with one of the timers to measure transitions on an input signal.

For software timekeeping, two additional 16-bit wakeup timers with 4 16-bit event registers are provided, generating an interrupt on match events.

## 5.3. UART

The **AX8052F131** features two universal asynchronous receiver transmitters. They use one of the timers as baud rate generator. Word length can be programmed from 5 to 9 bits.

## 5.4. SPI Master/Slave Controller

The **AX8052F131** features a master/slave SPI controller. Both 3 and 4 wire SPI variants are supported. In master mode, any of the on-chip oscillators or the system clock may be selected as clock source. An additional prescaler with divide by two capability provides additional clocking flexibility. Shift direction, as well as clock phase and inversion, are programmable.



5.5. ADC, Analog Comparators and Temperature Sensor

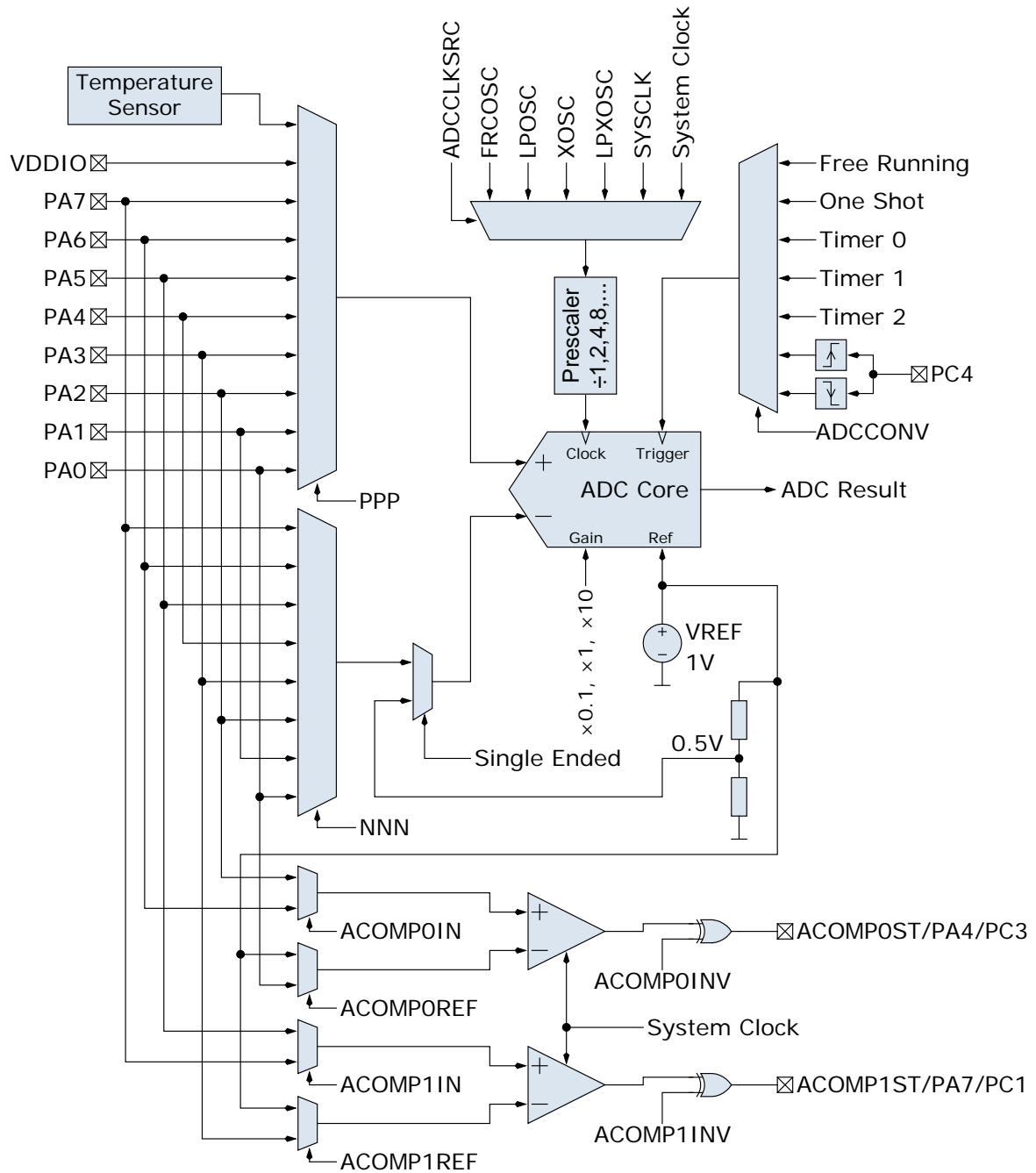

Figure 7 ADC Block Diagram

The **AX8052F131** features a 10-bit, 500 kSample/s Analog to Digital converter. The ADC supports both single ended and differential measurements. It uses an internal reference of 1 V. ×1, ×10 and ×0.1 gain modes are provided. The ADC may digitize signals on PA0...PA7, as well as VDD\_IO and an internal temperature sensor. The user can define four channels which are then converted sequentially and stored in four separate result registers. Each channel configuration consists of the multiplexer and the gain setting.



The **AX8052F131** contains an on-chip temperature sensor. Built-in calibration logic allows the temperature sensor to be calibrated in °C, °F or any other user defined temperature scale.

The **AX8052F131** also features two analog comparators. Each comparator can either compare two voltages on dedicated PA pins, or one voltage against the internal 1V reference. The comparator output can be routed to a dedicated digital output pin or can be read by software. The comparators are clocked with the system clock.

## 5.6. DMA Controller

The **AX8052F131** features a dual channel DMA engine. Each DMA channel can either transfer data from XRAM to almost any peripheral on chip, or from almost any peripheral to XRAM. Both channels may also be cross-linked for memory-memory transfers. The DMA channels use buffer descriptors to find the buffers where data is to be retrieved or placed, thus enabling very flexible buffering strategies.

The DMA channels access XRAM in a cycle steal fashion. They access XRAM whenever XRAM is not used by the microcontroller. Their priority is lower than the microcontroller, thus interfering very little with the microcontroller. Additional logic prevents starvation of the DMA controller.

## 5.7. AES Engine

The **AX8052F131** contains a dedicated engine for the government mandated Advanced Encryption Standard (AES). It features a dedicated DMA engine and reads input data as well as key stream data from the XRAM, and writes output data into a programmable buffer in the XRAM. The round number is programmable; the chip therefore supports AES-128, AES-192, and AES-256, as well as higher security proprietary variants. Keystream (key expansion) is performed in software, adding to the flexibility of the AES engine. ECB (electronic codebook), CFB (cipher feedback) and OFB (output feedback) modes are directly supported without software intervention.

## 5.8. Crystal Oscillator (RF reference oscillator)

The on-chip crystal oscillator allows the use of an inexpensive quartz crystal as the RF generation subsystem's timing reference. Although a wider range of crystal frequencies can be handled by the crystal oscillator circuit, it is recommended to use 16 MHz as reference frequency for ASK and PSK modulations independent of the data rate. For FSK it is recommended to use a 16 MHz crystal for data rates below 200 kbps and 24 MHz for data rates above 200 kbps.

The oscillator circuit is enabled by programming the transmitter **AX5031\_PWRMODE** register. At power-up it is not enabled.

To adjust the circuit's characteristics to the quartz crystal being used, without using additional external components, both the transconductance and the tuning capacitance of the crystal oscillator can be programmed.

The transconductance is programmed via register bits XTALOSCGM[3:0] in register **AX5031\_XTALOSC**.



The integrated programmable tuning capacitor bank makes it possible to connect the oscillator directly to pins CLK16N and CLK16P without the need for external capacitors. It is programmed using bits XTALCAP[5:0] in register **AX5031\_XTALCAP**.

Alternatively a single ended reference (TCXO, CXO) may be used. The CMOS levels should be applied to CLK16P via an AC coupling with the crystal oscillator enabled.

## 5.9. SYSCLK Output

The SYSCLK pin outputs the reference clock signal divided by a programmable integer. Divisions from 1 to 2048 are possible. For divider ratios > 1 the duty cycle is 50%. Bits SYSCLK[3:0] in the **AX5031\_PINCFG1** register set the divider ratio. The SYSCLK output can be disabled.

## 5.10. Power-on-reset (POR) and RESET\_N Input

**AX8052F131** has an integrated power-on-reset block which is edge sensitive to VDD\_IO. For many common application cases no external reset circuitry is required. However, if VDD\_IO ramps cannot be guaranteed, an external reset circuit is recommended. For detailed recommendations and requirements see the AX8052 Application Note: Power On Reset.

After POR or reset all registers are set to their default values.

The RESET\_N pin contains a weak pull-up. However, it is strongly recommended to connect the RESET\_N pin to VDD\_IO if not used, for additional robustness.

The **AX8052F131** can be reset by software as well. The microcontroller is reset by writing 1 to the SWRESET bit of the **PCON** register. The Transmitter can be reset by first writing 1 and then 0 to the RST bit in the **AX5031\_PWRMODE** register.



## 5.11. Ports

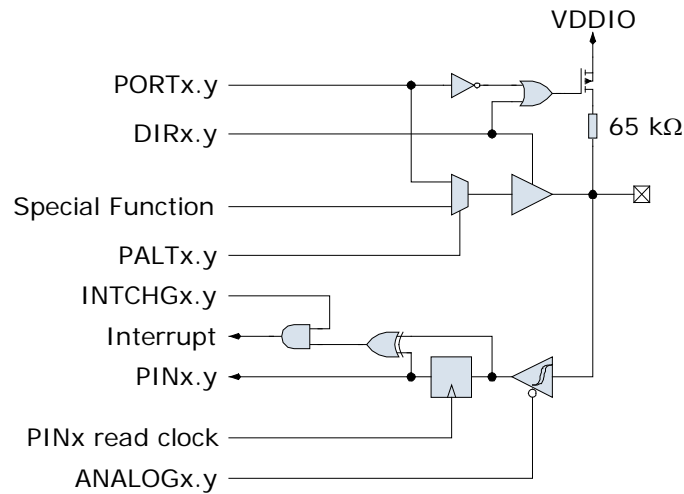

Figure 8 Port pin schematic

Figure 8 shows the GPIO logic. The DIR register bit determines whether the port pin acts as an output (1) or an input (0).

If configured as an output, the PALT register bit determines whether the port pin is connected to a peripheral output (1), or used as a GPIO pin (0). In the latter case, the PORT register bit determines the port pin drive value.

If configured as an input, the PORT register bit determines whether a pull-up resistor is enabled (1) or disabled (0). Inputs have schmitt-trigger characteristic. Port A inputs may be disabled by setting the ANALOGA register bit; this prevents additional current consumption if the voltage level of the port pin is mid-way between logic low and logic high, when the pin is used as an analog input.

Port A, B and C pins may interrupt the microcontroller if their level changes. The INTCHG register bit enables the interrupt. The PIN register bit reflects the value of the port pin. Reading the PIN register also resets the interrupt if interrupt on change is enabled.





## 6. Transmitter

The transmitter block is controllable through its registers, which are mapped into the X data space of the microcontroller. The transmitter block features its own 32 word × 10 bit FIFO. The microcontroller can either be interrupted at a programmable FIFO fill level, or one of the DMA channels can be instructed to transfer between XRAM and the transmitter FIFO.

### 6.1. RF Frequency Generation Subsystem

The RF frequency generation subsystem consists of a fully integrated synthesizer, which multiplies the reference frequency from the crystal oscillator to get the desired RF frequency. The advanced architecture of the synthesizer enables frequency resolutions of 1 Hz, as well as fast settling times of 5 – 50 μs depending on the settings (see section 4.3: AC Characteristics). Fast settling times mean fast start-up, which enables low-power system design.

The frequency must be programmed to the desired carrier frequency.

The synthesizer loop bandwidth can be programmed. This serves three purposes:

1. Start-up time optimization, start-up is faster for higher synthesizer loop bandwidths
2. TX spectrum optimization, phase-noise at 300 kHz to 1 MHz distance from the carrier improves with lower synthesizer loop bandwidths
3. Adaptation of the bandwidth to the data-rate. For transmission of FSK and MSK it is required that the synthesizer bandwidth must be in the order of the data-rate.

#### VCO

---

An on-chip VCO converts the control voltage generated by the charge pump and loop filter into an output frequency. The frequency can be programmed in 1 Hz steps in the **AX5031\_FREQ** registers. For operation in the 433 MHz band, the BANDSEL bit in the **AX5031\_PLLLOOP** register must be programmed.

#### VCO Auto-Ranging

---

The **AX8052F131** has an integrated auto-ranging function, which allows to set the correct VCO range for specific frequency generation subsystem settings automatically. Typically it has to be executed after power-up. The function is initiated by setting the RNG\_START bit in the **AX5031\_PLLRANGING** register. The bit is readable and a 0 indicates the end of the ranging process. The RNGERR bit indicates the correct execution of the auto-ranging.



## Loop Filter and Charge Pump

The **AX8052F131** internal loop filter configuration together with the charge pump current sets the synthesizer loop band width. The loop-filter has three configurations that can be programmed via the register bits FLT[1:0] in register **AX5031\_PLLLOOP**, the charge pump current can be programmed using register bits PLLCPI[1:0] also in register **AX5031\_PLLLOOP**. Synthesizer bandwidths are typically 50 - 500 kHz depending on the **AX5031\_PLLLOOP** settings, for details see the section 4.3: AC Characteristics.

## Registers

Register	Bits	Purpose
AX5031_PLLLOOP	FLT[1:0]	Synthesizer loop filter bandwidth, recommended usage is to increase the bandwidth for faster settling time, bandwidth increases of factor 2 and 5 are possible.
	PLLCPI[2:0]	Synthesizer charge pump current, recommended usage is to decrease the bandwidth (and improve the phase-noise) for low data-rate transmissions.
	BANSEL	Switches between 868 MHz/915 MHz and 433 MHz bands
AX5031_FREQ		Programming of the carrier frequency
AX5031_FREQB		Programming of the 2 <sup>nd</sup> carrier frequency, switch to this carrier frequency by setting bit FREQSEL=1.
AX5031_PLLRANGING		Initiate VCO auto-ranging and check results



## 6.2. RF Input and Output Stage (ANTP/ANTN)

The **AX8052F131** uses fully differential antenna pins.

The PA drives the signal generated by the frequency generation subsystem out to the differential antenna terminals. The output power of the PA is programmed via bits TXRNG[3:0] in the register **AX5031\_TXPWR**. Output power as well as harmonic content will depend on the external impedance seen by the PA, recommendations are given in section 7.1: Antenna Interface Circuitry.

## 6.3. Encoder

The encoder is located between the Framing Unit and the Modulator. It can optionally transform the bit-stream in the following ways:

- It can invert the bit stream.
- It can perform differential encoding. This means that a zero is transmitted as no change in the level, and a one is transmitted as a change in the level. Differential encoding is useful for PSK, because PSK transmissions can be received either as transmitted or inverted, due to the uncertainty of the initial phase. Differential encoding / decoding removes this uncertainty.
- It can perform Manchester encoding. Manchester encoding ensures that the modulation has no DC content and enough transitions (changes from 0 to 1 and from 1 to 0) for the demodulator bit timing recovery to function correctly, but does so at a doubling of the data rate.
- It can perform Spectral Shaping. Spectral Shaping removes DC content of the bit stream, ensures transitions for the demodulator bit timing recovery, and makes sure that the transmitted spectrum does not have discrete lines even if the transmitted data is cyclic. It does so without adding additional bits, i.e. without changing the data rate. Spectral Shaping uses a self synchronizing feedback shift register.

The encoder is programmed using the register **AX5031\_ENCODING**, details and recommendations on usage are given in the AX5031 Programming Manual.



## 6.4. Framing and FIFO

Most radio systems today group data into packets. The framing unit is responsible for converting these packets into a bit-stream suitable for the modulator.

The Framing unit supports three different modes:

- HDLC
- Raw
- 802.15.4 compliant

The microcontroller communicates with the framing unit through a 32 level × 10 bit FIFO. The FIFO decouples microcontroller timing from the radio (modulator) timing. The bottom 8 bits of the FIFO contain transmit data. The top 2 bit are used to convey meta information in HDLC and 802.15.4 modes. They are unused in Raw mode. The meta information consists of packet begin / end information and the result of CRC checks.

The FIFO can be operated in polled or interrupt driven modes. In polled mode, the microcontroller must periodically read the FIFO status register or the FIFO count register to determine whether the FIFO needs servicing.

In interrupt mode EMPTY, NOT EMPTY, FULL, NOT FULL and programmable level interrupts are provided. Interrupts are acknowledged by removing the cause for the interrupt, i.e. by emptying or filling the FIFO.

To lower the interrupt load on the microcontroller, one of the DMA channels may be instructed to transfer data between the transmitter FIFO and the XRAM memory. This way, much larger buffers can be realized in XRAM, and interrupts need only be serviced if the larger XRAM buffers fill or empty.



## HDLC Mode

---

**Note:** HDLC mode follows High-Level Data Link Control (HDLC, ISO 13239) protocol.

HDLC Mode is the main framing mode of the **AX8052F131**. In this mode, the **AX8052F131** performs automatic packet delimiting, and optional packet correctness check by inserting and checking a cyclic redundancy check (CRC) field.

The packet structure is given in the following table.

Flag	Address	Control	Information	FCS	Flag
8 bit	8 bit	8 or 16 bit	Variable length, 0 or more bits in multiples of 8	16 / 32 bit	8 bit

HDLC packets are delimited with flag sequences of content 0x7E.

In **AX8052F131** the meaning of address and control is user defined. The Frame Check Sequence (FCS) can be programmed to be CRC-CCITT, CRC-16 or CRC-32.

For details on implementing a HDLC communication see the AX5031 Programming Manual.

## RAW Mode

---

In Raw mode, the **AX8052F131** does not perform any packet delimiting or byte synchronization. It simply serializes transmit bytes.

This mode is ideal for implementing legacy protocols in software.

## 802.15.4 (ZigBee) DSSS

---

802.15.4 uses binary phase shift keying (PSK) with 300 kbit/s (868 MHz band) or 600 kbit/s (915 MHz band) on the radio. The usable bit rate is only a 15<sup>th</sup> of the radio bit rate, however. A spreading function in the transmitter expands the user bit rate by a factor of 15, to make the transmission more robust.

In 802.15.4 mode, the **AX8052F131** framing unit performs the spreading function according to the 802.15.4 specification.

The 802.15.4 is a universal DSSS mode, which can be used with any modulation or datarate as long as it does not violate the maximum data rate of the modulation being used. Therefore the maximum DSSS data rate is 16 kbps for FSK and 40 kbps for ASK and PSK.



## 6.5. Modulator

Depending on the transmitter settings the modulator generates various inputs for the PA:

Modulation	Bit = 0	Bit = 1	Main Lobe Bandwidth	Max. Bitrate
ASK	PA off	PA on	BW=BITRATE	2000kBit/s
FSK / MSK /GFSK	$\Delta f = -f_{\text{deviation}}$	$\Delta f = +f_{\text{deviation}}$	$BW = (1+h) \cdot \text{BITRATE}$	350kBit/s
PSK	$\Delta \Phi = 0^\circ$	$\Delta \Phi = 180^\circ$	BW=BITRATE	2000kBit/s

$h$  = modulation index. It is the ratio of the deviation compared to the bit-rate;  $f_{\text{deviation}} = 0.5 \cdot h \cdot \text{BITRATE}$ , **AX8052F131** can demodulate signals with  $h < 32$ .

ASK = amplitude shift keying

FSK = frequency shift keying

MSK = minimum shift keying; MSK is a special case of FSK, where  $h = 0.5$ , and therefore  $f_{\text{deviation}} = 0.25 \cdot \text{BITRATE}$ ; the advantage of MSK over FSK is that it can be demodulated more robustly.

PSK = phase shift keying

OQPSK = offset quadrature shift keying. The **AX8052F131** supports OQPSK. However, unless compatibility to an existing system is required, MSK should be preferred.

4-FSK = four frequencies are used to transmit two bits simultaneously during each symbol

Modulation	Symbol = 00	Symbol = 01	Symbol = 10	Symbol = 11	Max. Bitrate
4-FSK	$\Delta f = -3 \cdot f_{\text{deviation}}$	$\Delta f = -f_{\text{deviation}}$	$\Delta f = +f_{\text{deviation}}$	$\Delta f = +3 \cdot f_{\text{deviation}}$	400 kBit/s

All modulation schemes are binary.



## 6.6. PWRMODE Register

The **AX8052F131** transmitter features its own independent power management, independent from the microcontroller. While the microcontroller power mode is controlled through the **PCON** register, the **AX5031\_PWRMODE** register controls which parts of the transmitter are operating.

<b>AX5031_PWRMODE register</b>	<b>Name</b>	<b>Description</b>
0000	POWERDOWN	All digital and analog transmitter functions, except the register file, are disabled. VREG is reduced to conserve leakage power. The registers are still accessible.
0100	VREGON	All digital and analog transmitter functions, except the register file, are disabled. VREG, however is at its nominal value for operation, and all registers are accessible.
0101	STANDBY	The crystal oscillator is powered on; the transmitter is off.
1100	SYNTHTX	The synthesizer is running on the transmit frequency. The transmitter is still off. This mode is used to let the synthesizer settle on the correct frequency for transmit.
1101	FULLTX	Synthesizer and transmitter are running. Do not switch into this mode before the synthesizer has completely settled on the transmit frequency (in SYNTHTX mode), otherwise spurious spectral transmissions will occur.

A typical **AX5031\_PWRMODE** sequence for a transmit session:

<b>Step</b>	<b>PWRMODE[3:0]</b>	<b>Remarks</b>
1	POWERDOWN	
2	STANDBY	The settling time is dominated by the crystal used, typical value 3ms.
3	SYNTHTX	The synthesizer settling time is 5 – 50 $\mu$ s depending on settings, see section AC Characteristics
4	FULLTX	Data transmission
5	POWERDOWN	



## 7. Application Information

### Connecting to Debug Adapter

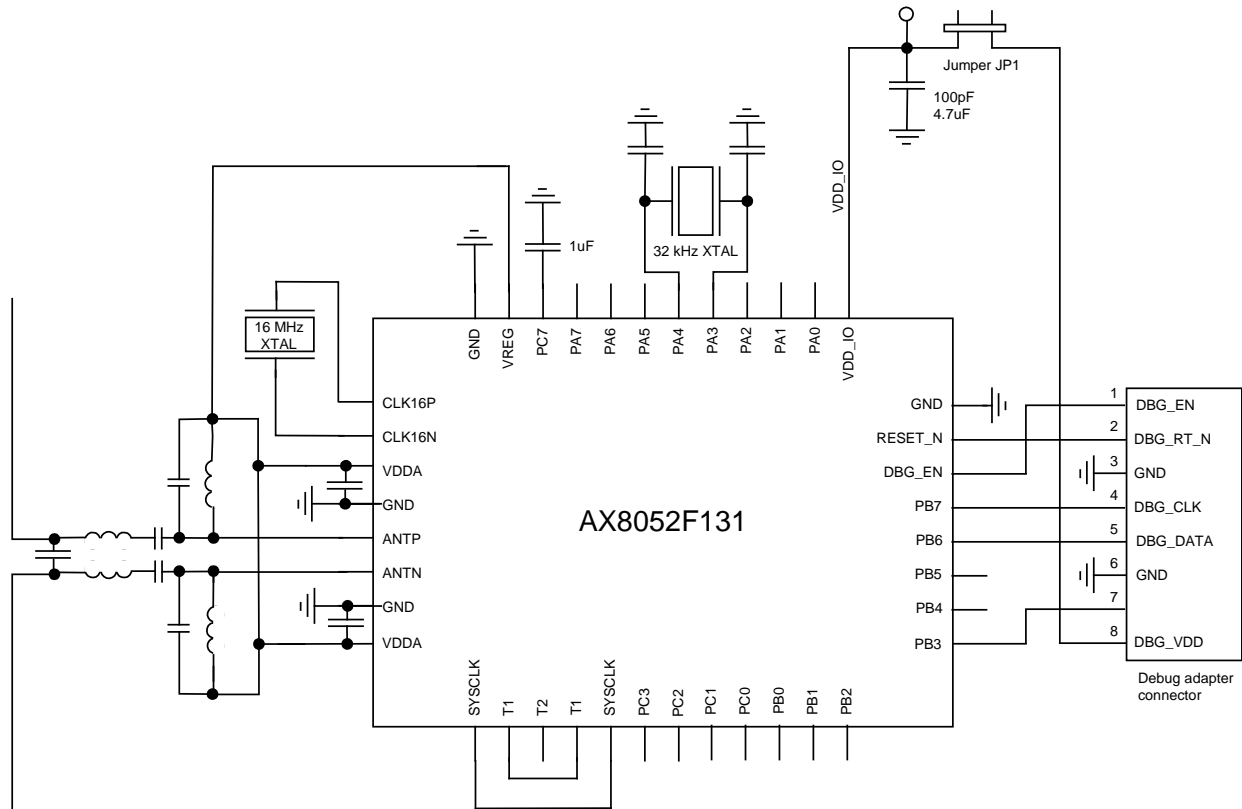

Figure 9 Typical application diagram with connection to the debug adapter

Short Jumper JP1-1 if it is desired to supply the target board from the Debug Adapter (50mA max). Connect the bottom exposed pad of the **AX8052F131** to ground.

If the debugger is not running, PB6 and PB7 are not driven by the Debug Adapter. If the debugger is running, the PB6 and PB7 values that the software reads may be set using the Pin Emulation feature of the debugger.

PB3 is driven by the debugger only to bring the **AX8052F131** out of Deep Sleep. It is high impedance otherwise.

The 32 kHz crystal is optional, the fast crystal at pins CLK16N and CLK16P is used as reference frequency for the RF RX/TX. Crystal load capacitances should be chosen according to the crystal's datasheet. At pins CLK16N and CLK16P they the internal programmable capacitors may be used, at pins PA3 and PA4 capacitors must be connected externally.

It is mandatory to add 1µF (low ESR) between VREG and GND.

Decoupling capacitors are not all drawn. It is recommended to add 100nF decoupling capacitor for





every VDDA and VDD\_IO pin. In order to reduce noise on the antenna inputs it is recommended to add 27 pF on the VDD pins close to the antenna interface.

The **AX8052F131** has an integrated voltage regulator for the analog supply voltages, which generates a stable supply voltage VREG from the voltage applied at VDD\_IO. Use VREG to supply all the VDDA supply pins and also to DC power to the pins ANTP and ANTN.

### 7.1. Antenna Interface Circuitry

The ANTP and ANTN pins provide RF output from the PA when **AX8052F131** is in transmitting mode. A small antenna can be connected with an optional translation network. The network must provide DC power to the PA. A biasing to VREG is necessary.

Beside biasing and impedance matching, the proposed networks also provide low pass filtering to limit spurious emission.

#### Single-Ended Antenna Interface

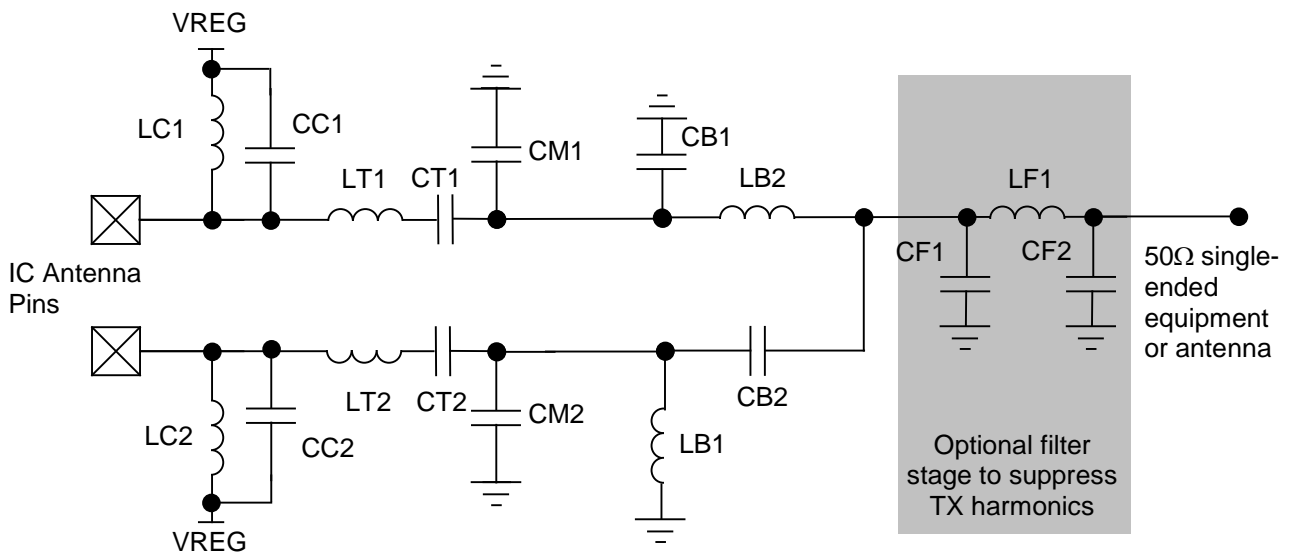

Figure 10 Structure of the antenna interface to 50 Ω single-ended equipment or antenna

Frequency Band	LC1,2 [nH]	CC1,2 [pF]	LT1,2 [nH]	CT1,2 [pF]	CM1,2 [pF]	LB1,2 [nH]	CB1,2 [pF]	LF1 [nH]	CF1,2 [pF]
868 / 915 MHz	68	1.2	12	18	2.4	12	2.7	0 OHM	N.C.
433 MHz	120	2.7	39	7.5	6.0	27	5.2	0 OHM	N.C.



## 8. QFN40 Package Information

### 8.1. Package Outline QFN40

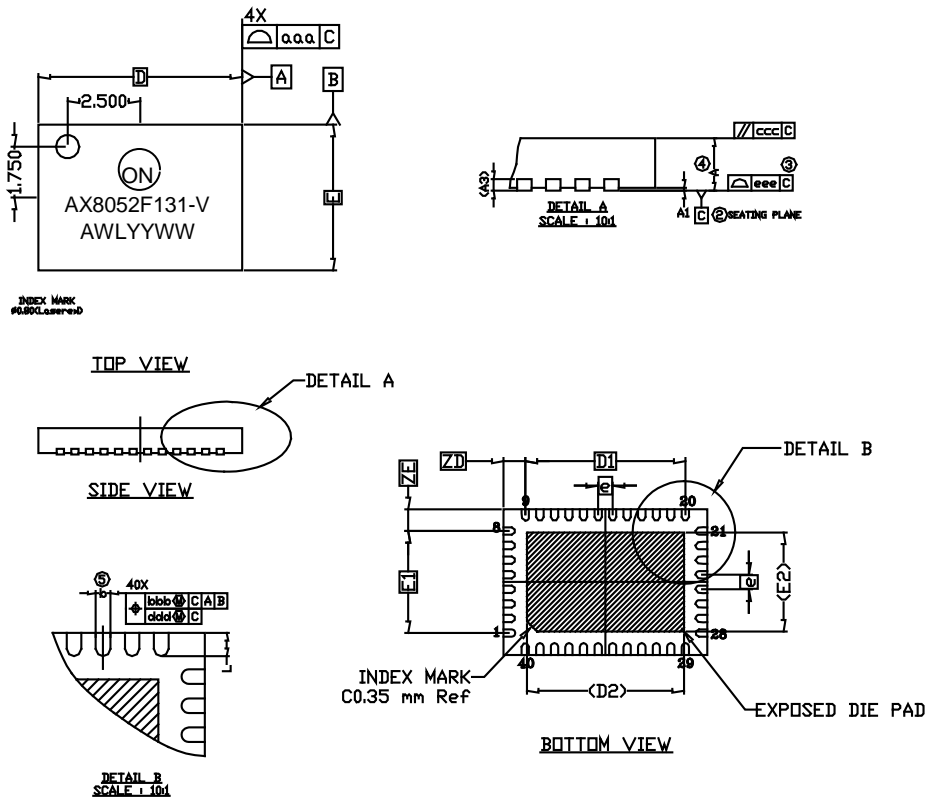

DIMENSIONAL REFERENCES			
REF.	Min.	Nom.	Max.
A	0.80	0.90	1.00
A1	0	0.02	0.05
A3	0.20 Ref		
D	7.00 BSC		
D1	5.50 BSC		
E	5.00 BSC		
E1	3.50 BSC		
e	0.50 BSC		
ZD	0.75 BSC		
ZE	0.75 BSC		

TOLERANCE OF FORM AND POSITION	
REF.	Units: mm
aaa	0.15
bbb	0.10
ccc	0.10
ddd	0.05
eee	0.08

Package marking  
 V silicon version  
 YY packaging year  
 WW packaging week  
 XXXX silicon code

LF REF#.	Symbol	Min	Nom	Max
FR9020	b	0.18	0.25	0.30
	L	0.30	0.40	0.50
	D2	5.30	5.40	5.50
	E2	3.30	3.40	3.50

#### Notes

- 'e' represents the basic terminal pitch
- Datum 'C' is the mounting surface with which the package is in contact.
- '3' specifies the vertical shift of the flat part of each terminal from the mounting surface.
- Dimension 'A' includes package warpage.
- Dimension 'b' applies to the metallised terminal and is measured between 0.15 to 0.30 mm from the terminal tip. If the terminal has the optional radius on the other end of the terminal, the dimension 'b' should not be measured in the radius arc
- Package dimension take reference from JEDEC MO-220
- AWLYYWW is the packaging lot code
- V is the device version
- RoHS



8.2. QFN40 Soldering Profile

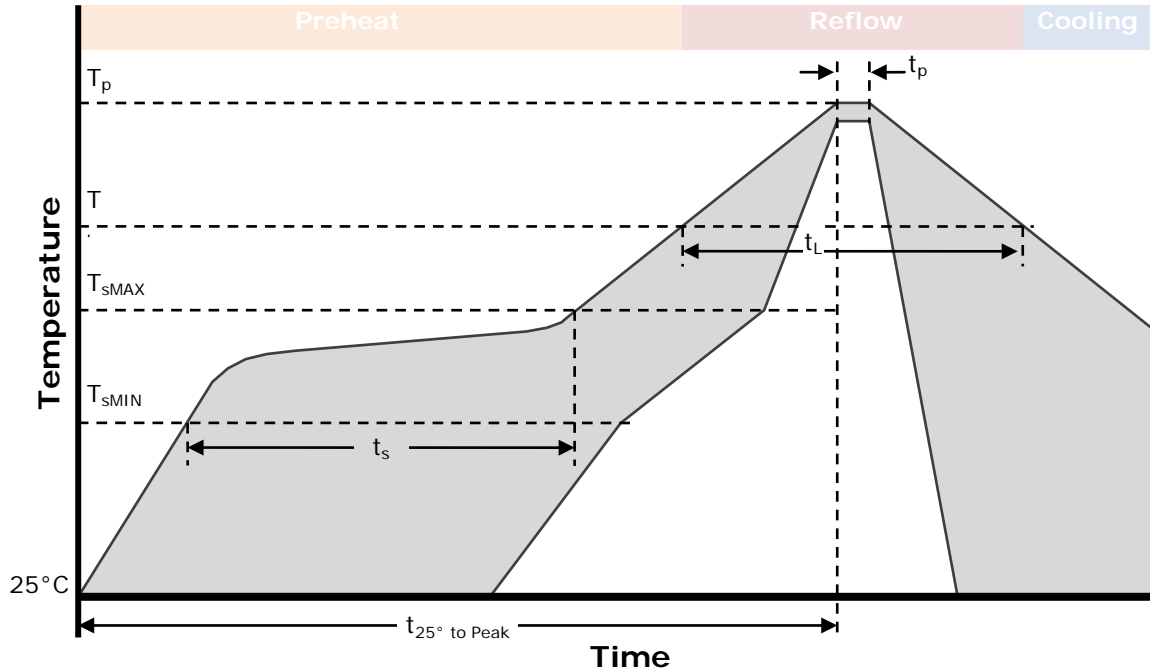

Profile Feature		Pb-Free Process
Average Ramp-Up Rate		3 °C/sec max.
Preheat Preheat		
Temperature Min	T <sub>sMIN</sub>	150°C
Temperature Max	T <sub>sMAX</sub>	200°C
Time (T <sub>sMIN</sub> to T <sub>sMAX</sub> )	t <sub>s</sub>	60 – 180 sec
Time 25°C to Peak Temperature	T <sub>25° to Peak</sub>	8 min max.
Reflow Phase		
Liquidus Temperature	T <sub>L</sub>	217°C
Time over Liquidus Temperature	t <sub>L</sub>	60 – 150 sec
Peak Temperature	t <sub>p</sub>	260°C
Time within 5°C of actual Peak Temperature	T <sub>p</sub>	20 – 40 sec
Cooling Phase		
Ramp-down rate		6°C/sec max.

Notes:

All temperatures refer to the top side of the package, measured on the package body surface.



### 8.3. QFN40 Recommended Pad Layout

1. PCB land and solder masking recommendations are shown in Figure 11.

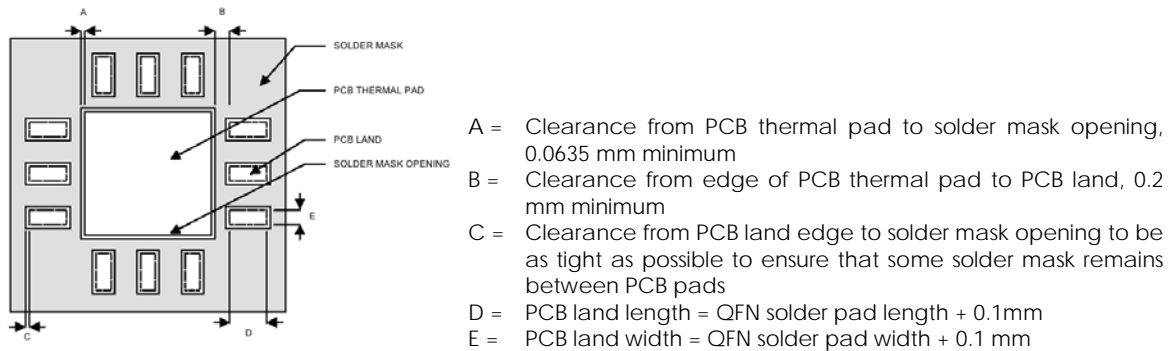

Figure 11 PCB land and solder mask recommendations

2. Thermal vias should be used on the PCB thermal pad (middle ground pad) to improve thermal conductivity from the device to a copper ground plane area on the reverse side of the printed circuit board. The number of vias depends on the package thermal requirements, as determined by thermal simulation or actual testing.
3. Increasing the number of vias through the printed circuit board will improve the thermal conductivity to the reverse side ground plane and external heat sink. In general, adding more metal through the PC board under the IC will improve operational heat transfer, but will require careful attention to uniform heating of the board during assembly.

### 8.4. Assembly Process

#### Stencil Design & Solder Paste Application

1. Stainless steel stencils are recommended for solder paste application.
2. A stencil thickness of 0.125 – 0.150 mm (5 – 6 mils) is recommended for screening.
3. For the PCB thermal pad, solder paste should be printed on the PCB by designing a stencil with an array of smaller openings that sum to 50% of the QFN exposed pad area. Solder paste should be applied through an array of squares (or circles) as shown in Figure 12.
4. The aperture opening for the signal pads should be between 50-80% of the QFN pad area as shown in Figure 13.
5. Optionally, for better solder paste release, the aperture walls should be trapezoidal and the corners rounded.
6. The fine pitch of the IC leads requires accurate alignment of the stencil and the printed circuit board. The stencil and printed circuit assembly should be aligned to within + 1 mil prior to application of the solder paste.
7. No-clean flux is recommended since flux from underneath the thermal pad will be difficult to clean if water-soluble flux is used.

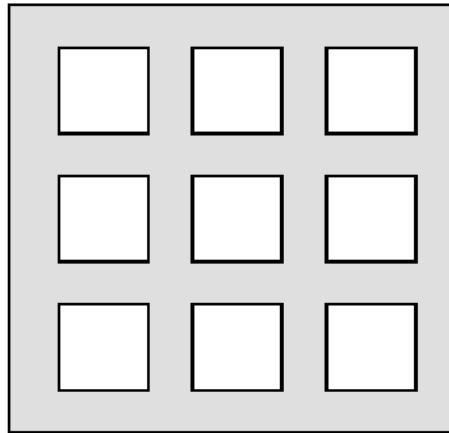

Figure 12 Solder paste application on exposed pad

Minimum  
50% coverage

62% coverage

Maximum  
80% coverage

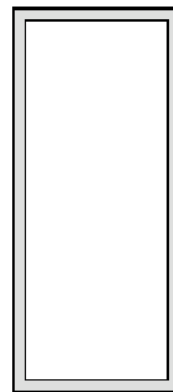
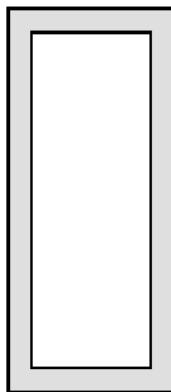
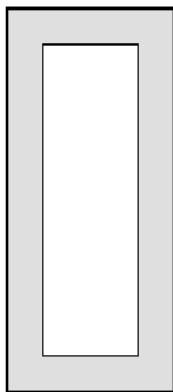



Figure 13 Solder paste application on pins



## 9. Device Versions

Device Marking	AX8052 Version	AX5031 Version
AX8052F131-2	1C	1

ON Semiconductor and the  are registered trademarks of Semiconductor Components Industries, LLC (SCILLC) or its subsidiaries in the United States and/or other countries. SCILLC owns the rights to a number of patents, trademarks, copyrights, trade secrets, and other intellectual property. A listing of SCILLC's product/patent coverage may be accessed at [www.onsemi.com/site/pdf/Patent-Marking.pdf](http://www.onsemi.com/site/pdf/Patent-Marking.pdf). SCILLC reserves the right to make changes without further notice to any products herein. SCILLC makes no warranty, representation or guarantee regarding the suitability of its products for any particular purpose, nor does SCILLC assume any liability arising out of the application or use of any product or circuit, and specifically disclaims any and all liability, including without limitation special, consequential or incidental damages. "Typical" parameters which may be provided in SCILLC data sheets and/or specifications can and do vary in different applications and actual performance may vary over time. All operating parameters, including "Typicals" must be validated for each customer application by customer's technical experts. SCILLC does not convey any license under its patent rights nor the rights of others. SCILLC products are not designed, intended, or authorized for use as components in systems intended for surgical implant into the body, or other applications intended to support or sustain life, or for any other application in which the failure of the SCILLC product could create a situation where personal injury or death may occur. Should Buyer purchase or use SCILLC products for any such unintended or unauthorized application, Buyer shall indemnify and hold SCILLC and its officers, employees, subsidiaries, affiliates, and distributors harmless against all claims, costs, damages, and expenses, and reasonable attorney fees arising out of, directly or indirectly, any claim of personal injury or death associated with such unintended or unauthorized use, even if such claim alleges that SCILLC was negligent regarding the design or manufacture of the part. SCILLC is an Equal Opportunity/Affirmative Action Employer. This literature is subject to all applicable copyright laws and is not for resale in any manner.

### PUBLICATION ORDERING INFORMATION

#### LITERATURE FULFILLMENT:

Literature Distribution Center for ON Semiconductor  
19521 E. 32nd Pkwy, Aurora, Colorado 80011 USA  
Phone: 303-675-2175 or 800-344-3860 Toll Free USA/Canada  
Fax: 303-675-2176 or 800-344-3867 Toll Free USA/Canada  
Email: [orderlit@onsemi.com](mailto:orderlit@onsemi.com)

**N. American Technical Support:** 800-282-9855 Toll Free  
USA/Canada

**Europe, Middle East and Africa Technical Support:**  
Phone: 421 33 790 2910

**Japan Customer Focus Center**  
Phone: 81-3-5817-1050

**ON Semiconductor Website:** [www.onsemi.com](http://www.onsemi.com)

**Order Literature:** <http://www.onsemi.com/orderlit>

For additional information, please contact your local Sales Representative