

Product Data Sheet RER220-43/18/2TDMO

**ebmpapst**

Die Wahl der Ingenieure



# RER220-43/18/2TDMO

## INDEX

<b>1</b>	<b>General</b> .....	<b>3</b>
<b>2</b>	<b>Mechanics</b> .....	<b>3</b>
2.1	General .....	3
2.2	Connections .....	3
<b>3</b>	<b>Operating Data</b> .....	<b>4</b>
3.1	Operating Data - Electrical Interface - Input .....	4
3.2	Electrical Operating Data .....	7
3.3	Operating Data - Electrical Interface -Output .....	7
3.4	Electrical Features .....	8
3.5	Data according ErP directive .....	9
3.6	Aerodynamic .....	9
<b>4</b>	<b>Environment</b> .....	<b>11</b>
4.1	General .....	11
4.2	Climatic requirements*).....	11
<b>5</b>	<b>Safety</b> .....	<b>12</b>
5.1	Electrical Safety .....	12
5.2	Approval Tests .....	12
<b>6</b>	<b>Reliability</b> .....	<b>12</b>
6.1	General .....	12

**1 General**

Fan type	Blower without chassis with intake nozzle	
Rotational direction looking at rotor	clockwise	
Airflow direction	Air in axially, Air out radially	
Bearing system	Ball bearing	
Mounting position	any	

**2 Mechanics**

**2.1 General**

Depth	71 mm	
Diameter	220 mm	
Weight	0,89 kg	
Housing material		
Impeller material	Plastic	

**2.2 Connections**

Electrical connection	Wires	
Length of lead wire	L = 425 mm	
Tolerance	+/- 10,0 mm	
Length of tube	S = 135 mm	
Tolerance	+/- 5 mm	
Wire gauge (AWG)	22	
Insulation diameter	1,35 mm	

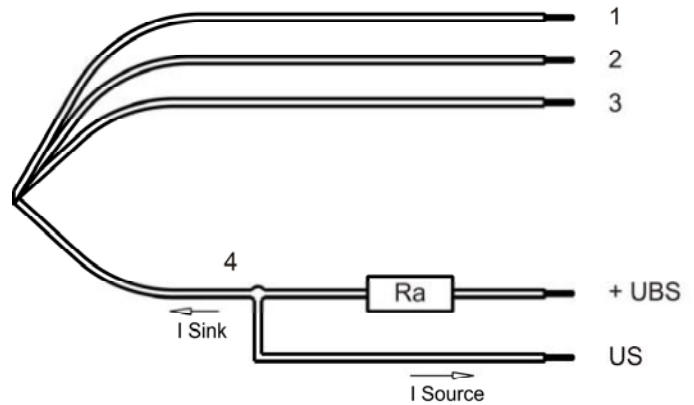

	Colour	Operation
Wire 1	red	+ UB
Wire 2	blue	- GND
Wire 3	violet	CONTR
Wire 4	white	Tacho

The auxiliaries shown on the schematic diagram (which are required for the intended use) are not part of our delivery.

Lead wire 1 - 2: AWG22

Lead wire 3 - 4: AWG22 (Insulation diameter 1,35mm)

### 3 Operating Data

#### 3.1 Operating Data - Electrical Interface - Input

Control input	Analog
---------------	--------

#### Features

PWM - Frequency	1 kHz - 10 kHz Typical: 2 kHz
Input voltage range	0 V - 10 V

#### Characteristics

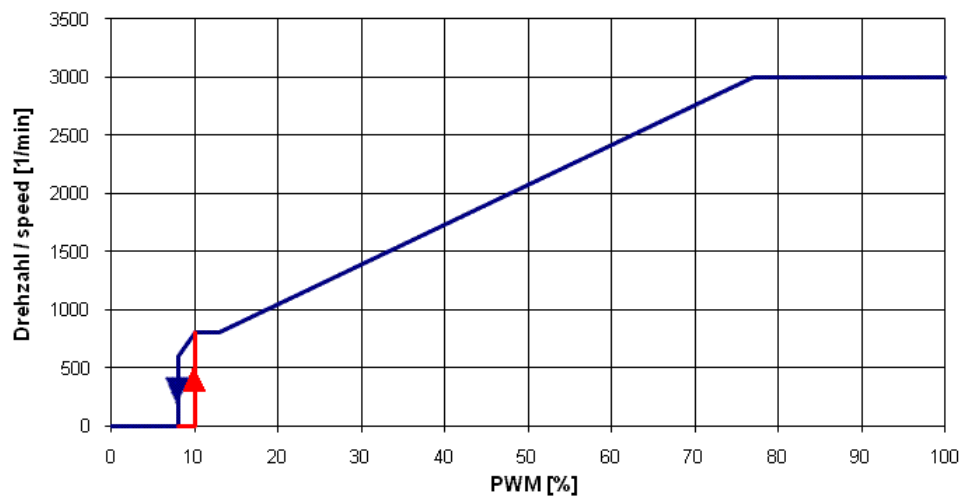
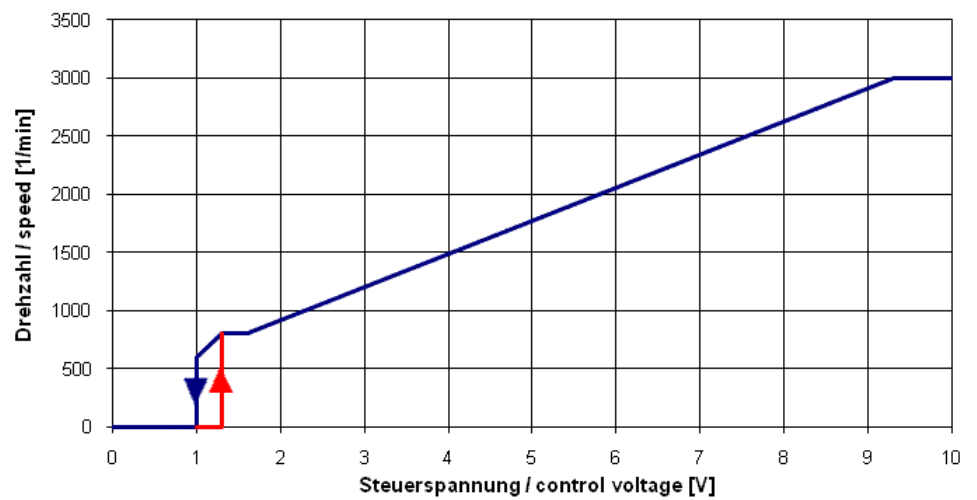

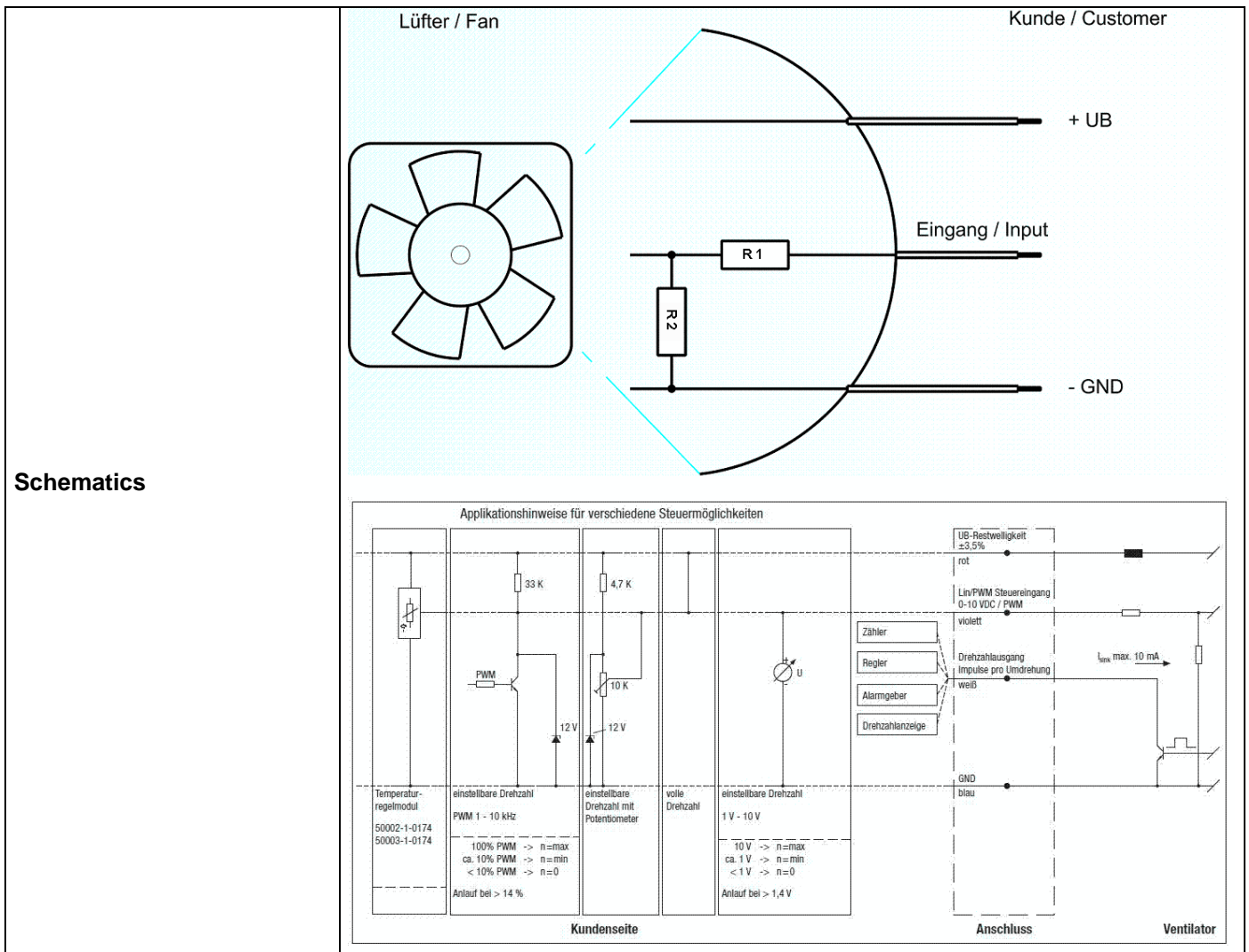

**Input voltage divider:**

R1 = 47 kOhm

R2 = 36 kOhm

For protection: There is parallel to R2 a 5,1 V Z-Diode

**Speed control:**

By pulse-width modulation (PWM) 0 ... 100%

with switching transistor in emitter circuit and collector resistance to 12 V

Frequency = 2 kHz (1 - 10 kHz)

**Information to the curve PWM:**

0% - <10% PWM:

0 1/min

10% PWM:

800 1/min (Fan on, coming from 0% PWM)

10% - 13% PWM:

800 1/min (corresponding to min. speed)

13% - 78% PWM:

linear increasing curve

78% - 100% PWM:

3000 1/min (corresponding to max. speed)

10% - >8% PWM:

linear decreasing curve (coming from 100% PWM)

8% PWM:

600 1/min or 0 1/min (Fan off, coming from 100% PWM)

oder:

**Speed control:**

By analog voltage 0 - 10 V

Information to the curve analog:

0 V - < 1,3 V:

1,3 V:

1,3 V - 1,6 V:

1,6 V - 9,4 V:

9,4 V - 10 V:

1,3 V - > 1,0 V:

1,0 V:

0 1/min

800 1/min (Fan on, coming from 0 V)

800 1/min (corresponding to min. speed)

linear increasing curve

3000 1/min (corresponding to max. speed)

linear decreasing curve (coming from 10 V)

600 1/min or 0 1/min (Fan off, coming from 10 V)

All values are measured in the housing!

**Fan doesn't have a sensor break detection!**

**3.2 Electrical Operating Data**

Measurement conditions: Normal air density = 1,2 kg/m<sup>3</sup>; Temperature 23°C +/- 3°C; Motor axis horizontal; warm-up time before measuring 5 minutes (unless otherwise specified).  
In the intake and outlet area should not be any solid obstruction within 0,5 m.

Measurement setup:	Measured between two steel plates
Steel plate:	225 mm x 225 mm
Intake nozzle:	D: 155 mm; R: 25 mm
Distance between bottom and top plate:	90 mm
Overlapping impeller / nozzle:	2 mm

$\Delta p = 0$ : corresp. to free air flow (see section 3.5)  
I: corresp. to arithm. mean current value

Name	Condition
U Contr. 0001	U Contr.: 10 V

Features	Condition	Symbol	Values		
Voltage range	$\Delta p = 0$	U	36,0 V		72,0 V
Nominal voltage	$\Delta p = 0$	$U_N$		48,0 V	
Power consumption	$\Delta p = 0$	P	102,9 W	109,4 W	107,3 W
Tolerance	U Contr. 0001		+/- 10,0 %	+/- 10,0 %	+/- 10,0 %
Current consumption	$\Delta p = 0$	I	2.860 mA	2.280 mA	1.490 mA
Tolerance	U Contr.0001		+/- 10,0 %	+/- 10,0 %	+/- 10,0 %
Speed	$\Delta p = 0$	n	2.970 1/min	3.000 1/min	3.000 1/min
Tolerance	U Contr. 0001		+/- 7,5 %	+/- 5,0 %	+/- 5,0 %
Starting current consumption				3.000 mA	
max. allowed input voltage ripple (within the specified voltage range)			+/- 3 %		
max. allowed input voltage ripple (within the specified voltage range)			>= 50 Hz		

Name	Condition
U Contr. 0002	U Contr.: 5 V

Features	Condition	Symbol	Values		
Voltage range	$\Delta p = 0$	U	36,0 V		72,0 V
Nominal voltage	$\Delta p = 0$	$U_N$		48,0 V	
Power consumption	$\Delta p = 0$	P	21,9 W	24,9 W	23,8 W
Tolerance	U Contr. 0002		+/- 10,0 %	+/- 10,0 %	+/- 10,0 %
Current consumption	$\Delta p = 0$	I	610 mA	520 mA	330 mA
Tolerance	U Contr. 0002		+/- 10,0 %	+/- 10,0 %	+/- 10,0 %
Speed	$\Delta p = 0$	n	1.770 1/min	1.800 1/min	1.800 1/min
Tolerance	U Contr. 0002		+/- 7,5 %	+/- 5,0 %	+/- 5,0 %

The data at 5V are no FK features and need not be tested.

**3.3 Operating Data - Electrical Interface -Output**

Tacho type	/2 (Open collector)
------------	---------------------

**Signal-Ausgangsspannung / Signal output voltage**

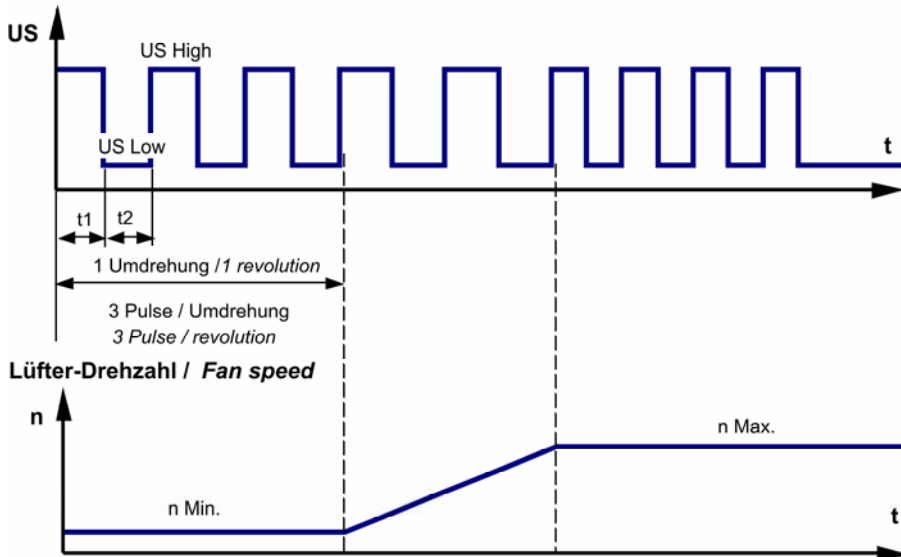

Features	Note	Values
Tacho operating voltage (UBS)		$\leq 60\text{ V}$
Tacho signal Low	I sink: 2 mA	$\leq 0,4\text{ V}$
Tacho signal High	I source: 0 mA	$\leq 60\text{ V}$
Maximum sink current		$\leq 20\text{ mA}$
External resistor	External resistor Ra from UBS to US required. All voltages measured to GND.	
Tacho frequency	$(3 \times n) / 60$	150 Hz
Tacho isolated from motor	No	
Slew rate		$\Rightarrow 0,5\text{ V/us}$

**Please note:**

At zero speed the tacho signal is at a static HIGH. It will be also HIGH when the fan is still spinning, but the speed control signal is set to zero speed already.  
The tacho signal is only activated after the start-up is completed.

Alarm type	None
------------	------

**3.4 Electrical Features**

Electronic function	Speed-Controlled	
Reversed polarity protection	P-CH FET	
Max. residual current at Un	IF $\leq 5\text{ mA}$	
Locked rotor protection	Auto restart	
Locked rotor current at Un	approx. 3.000 mA	
Clock signal t3/t4 at locked rotor	Typical: 7,8 s / 10 s	



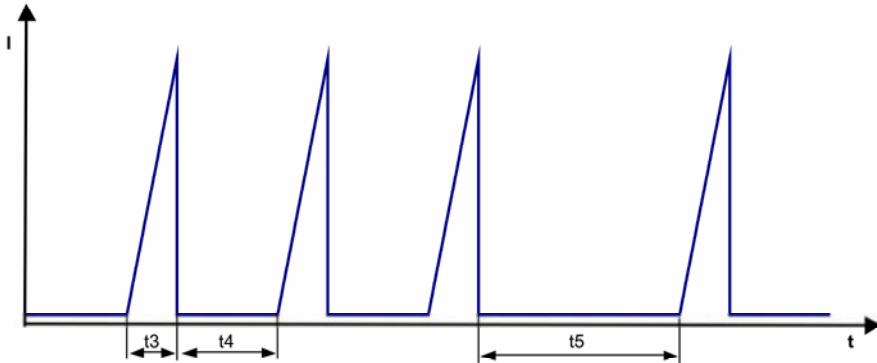

Locked rotor signal t5 50s:

After 2 failed start-ups there is an extended timeout of 50 s.

### 3.5 Data according ErP directive

Installation / Efficiency category	A / static
Speed control	integrated
Specific ratio	1,00394
Target overall efficiency 2015	42,3 %
Overall efficiency	54,0 %
Efficiency grade	62
Power input	132,6 W
Speed	2.970 1/min

All values measured in optimum energy efficiency point.

Productiondatecode is printed on the fan label.

### 3.6 Aerodynamic

Measurement conditions: Measured with a double chamber intake rig acc. to DIN EN ISO 5801.  
 Normal air density = 1,2 kg/m<sup>3</sup>; Temperature 23°C +/- 3°C;  
 In the intake and outlet area should not be any solid obstruction within 0,5 m.  
 The information is only valid under the specified test conditions and may be changed by the installation conditions. If there are deviations from the standard test conditions, the characteristic values must be checked under the installed conditions.

Measurement setup:	Measured between two steel plates
Steel plate:	225 mm x 225 mm
Intake nozzle:	D: 155 mm; R: 25 mm
Distance between bottom and top plate:	90 mm
Overlapping impeller / nozzle:	2 mm

a.) Operation condition:

3.000 1/min at free air flow	U Contr. 10 V	
Max. free-air flow ( $\Delta p = 0 / \dot{V} = \text{max.}$ )		1.063,0 m <sup>3</sup> /h
Max. static pressure ( $\Delta p = \text{max.} / \dot{V} = 0$ )		525 Pa

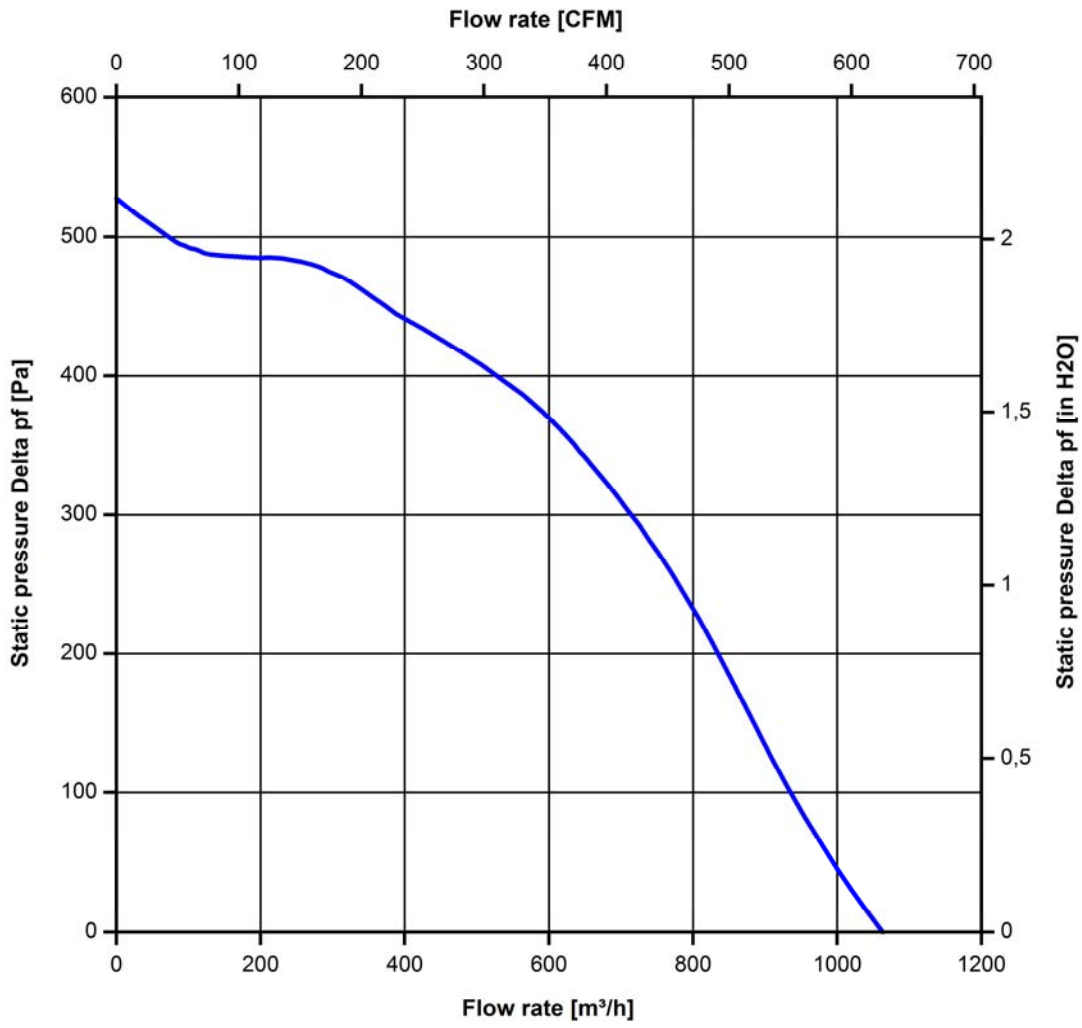

## 4 Environment

### 4.1 General

Min. permitted ambient temperature TU min.	-20 °C	
Max. permitted ambient temperature TU max.	55 °C	
Min. permitted storage temperature TL min.	-40 °C	
Max. permitted storage temperature TL max.	80 °C	

### 4.2 Climatic requirements\*)

Humidity requirements	humid heat, constant; according to DIN EN 60068-2-78, 14 days	
Water exposure	None	
Dust requirements	None	
Salt fog requirements	None	

\*) Permitted application area:

The product is intended for use in sheltered rooms with controlled temperature and controlled humidity. Directly exposure to water must be avoided.

Pollution degree 1 (according DIN EN 60664-1)

There is either no pollution or it occurs only dry, non-conductive pollution. The pollution has no negative impact.

## 5 Safety

### 5.1 Electrical Safety

Dielectric strength DIN EN 60950 (VDE 0805) and DIN EN 60335 (VDE 0700) A.) Type test Measuring conditions: After 48h of storage at 95% R.H. and 25°C. No arcing or breakdown is allowed! All connections together to ground. B.) Routine test Measuring conditions: At indoor climate. No arcing or breakdown is allowed! All connections together to ground.	1000 VAC / 1 Min.  1000 VAC / 1 Sec.	
Isolation resistance Measuring conditions: After 48h of storage at 95% R.H. and 25°C measured with U=500 VDC for 1 min.	RI > 10 MOhm	
clearance / creepage distance	1,0 mm / 1,5 mm	
Protection class	I	

### 5.2 Approval Tests

CE	EC Declaration of Conformity	No
EAC	Eurasian Conformity	Yes
UL	Underwriters Laboratories	Yes / UL507, Electric Fans
VDE	Association for Electrical, Electronic and Information Technologies	Yes / Approval acc. to EN 60950 (VDE 0805) - Information technology equipment
CSA	Canadian Standards Association	Yes / CSA audited by UL according to C22.2 No. 113 Fans and Ventilators
CCC	China Compulsory Certification	No

## 6 Reliability

### 6.1 General

Life expectancy L10 at TU = 40 °C	65.000 h	
Life expectancy L10 at TU max.	45.000 h	

Hinweis: Diese technische Zeichnung ist verbindlich für die Ausführung. Der Kunde ist verpflichtet, sich vor der Ausführung von Änderungen an der Ausführung zu vergewissern. Bei Änderungen ist der Kunde für die Einhaltung der Fertigungsbedingungen zu sorgen.

Maßstab: nach DIN 2430 (1:2) basierend auf den Produktspezifikationen der Kunden.

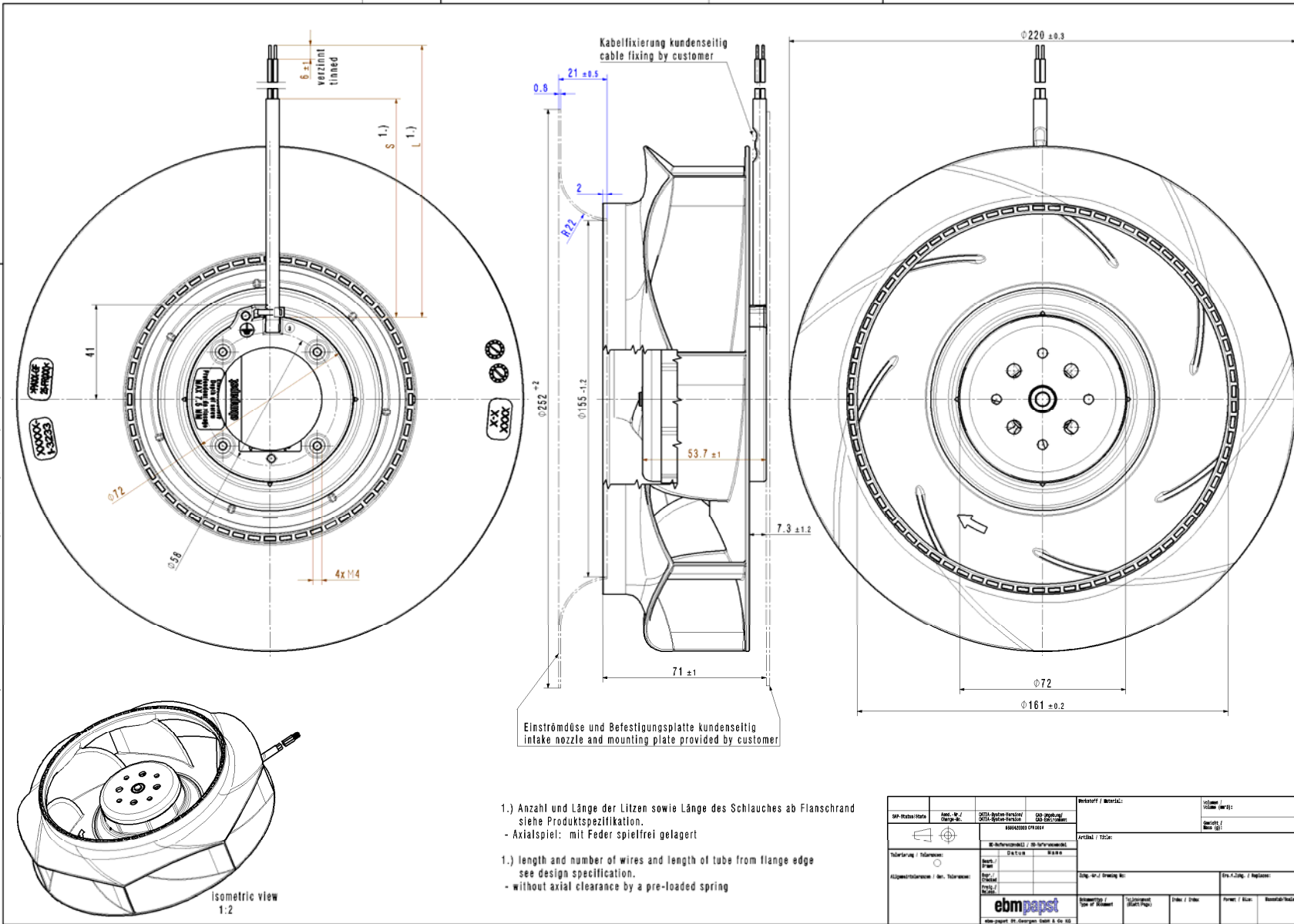

- 1.) Anzahl und Länge der Litzen sowie Länge des Schlauches ab Flanschrand  
siehe Produktspezifikation.  
- Axialspiel: mit Feder spielfrei gelagert
- 1.) length and number of wires and length of tube from flange edge  
see design specification.  
- without axial clearance by a pre-loaded spring

SP-Modellcode	Mod. Nr. / Order No.	SPZ-Systemfunktion SPZ-Systemfunktion	SPZ-Systemcode SPZ-Systemcode	Revisions- / Merkmal:	Volumen / Volume (m³)
SP-Systemfunktion				Revisions- / Merkmal:	Quantität / Quantity
© Schutzrechte (Patent) / © Schutzrechte (Patent)				Revisions- / Merkmal:	
Teilenummer / Part Number	Druck / Pressure	Material / Material	Werkstoff / Material	Revisions- / Merkmal:	
Allgemeine Informationen / General Information				Revisions- / Merkmal:	
<b>ebmpapst</b>				Revisions- / Merkmal:	
www.ebmpapst.com				Revisions- / Merkmal:	