

ILB BT ADIO MUX ...

**Wireless-MUX module with 16 digital inputs,
16 digital outputs, 2 analog inputs,
and 2 analog outputs**

Data sheet
7173_en_09

© PHOENIX CONTACT 2015-03-25



1 Description

The set consists of two modules that form a fixed pair (master and slave).

The Wireless-MUX module uses wireless transmission to send 16 digital and 2 analog signals bidirectionally, i.e., in both directions, which means that it can replace a 40-wire signal cable. The signal, which is connected to an input of the Wireless-MUX module, is output at the corresponding output of the Wireless-MUX module that consists of the fixed pair.

The wireless solution has been developed especially for use under industrial conditions and features ruggedness, reliability, and easy operation.



Please note the maximum permissible transmission power for the country of use.
For the latest country registrations, please visit phoenixcontact.net/products.



Make sure you always use the latest documentation.
It can be downloaded at phoenixcontact.net/products.



This data sheet is valid for all products listed under "Ordering data" on page 4.

1.1 Features of the ILB BT ADIO MUX wireless interface

- Bluetooth 1.2, HID profile
- Frequency range 2.402 GHz ... 2.480 GHz, ISM band
- Transmission power is controlled automatically
- Diagnostics and status indicators

1.2 Features of digital inputs

- Connections for 16 digital sensors
- Connection of sensors in 1-wire technology

1.3 Features of digital outputs

- Connections for 16 digital actuators
- Connection of actuators in 1-wire technology
- Nominal current of each output: 0.5 A
- Total current of all outputs: 8 A
- Short-circuit and overload-protected outputs
- Diagnostics and status indicators

1.4 Features of analog inputs

- Two analog single-ended signal inputs for the connection of either voltage or current signals
- Connection of sensors in 2 and 3-wire technology
- Current measuring range 0 mA ... 20 mA
- Voltage measuring range 0 V ... 10 V

1.5 Features of analog outputs

- Two analog single-ended signal outputs for the connection of either voltage or current signals
- Connection of actuators in 2 and 3-wire technology
- Current measuring range 0 mA ... 20 mA
- Voltage measuring range 0 V ... 10 V

For the ILB BT ADIO MUX-OMNI 8/M version (Order No. 2693185), type tests have been passed at the following institutes.

Supplementary type approval terms and conditions

Type approval certifies that a representative sample of the product(s) referred to herein has/have been found to meet the applicable design criteria for the use specified herein. It does not mean or imply approval for any other use, nor approval of any product(s) designed or manufactured otherwise than in strict conformity with the said representative sample.

Type approval is based on the understanding that the manufacturer's recommendations and instructions and any relevant requirements of the rules and regulations are complied with.

Type approval does not eliminate the need for normal inspection and survey procedures required by the rules and regulations.



This version has been approved for shipbuilding and off/onshore applications.

2 Table of contents

1	Description.....	1
1.1	Features of the ILB BT ADIO MUX wireless interface.....	2
1.2	Features of digital inputs	2
1.3	Features of digital outputs	2
1.4	Features of analog inputs	2
1.5	Features of analog outputs.....	2
2	Table of contents	3
3	Ordering data.....	4
4	Technical data	5
5	Usage notes	11
6	Local diagnostics and status indicators	12
7	Connecting the supply, actuators, and sensors	13
7.1	Terminal point assignment of the power connector	13
7.2	Terminal point assignment of the digital output and input connectors	13
7.3	Terminal point assignment of the analog output connector	13
7.4	Terminal point assignment of the analog input connector.....	13
8	Internal basic circuit diagram	14
9	Connection example	15
10	Assignment of terminal points to the remote station.....	16
11	Diagnostics.....	16
11.1	Error table with status indicators.....	16
12	Antennas	17
12.1	Antenna alignment	17
12.2	Omnidirectional antennas.....	18
12.3	Panel antennas	20

3 Ordering data

Modules

Description	Type	Order No.	Pcs. / Pkt.
Wireless-MUX set, consisting of 2 modules with 16 digital inputs and outputs and 2 analog inputs and outputs each as well as 2 omnidirectional antennas 14 dBm transmission power	ILB BT ADIO MUX-OMNI	2884208	1 set
Wireless-MUX set, consisting of 2 modules with 16 digital inputs and outputs and 2 analog inputs and outputs each as well as 2 panel antennas 8 dBm transmission power	ILB BT ADIO MUX-PANEL	2884509	1 set
Wireless-MUX set, consisting of 2 modules with 16 digital inputs and outputs and 2 analog inputs and outputs each as well as 2 omnidirectional antennas 8 dBm transmission power With maritime approval	ILB BT ADIO MUX-OMNI 8/M	2693185	1 set



Send us both associated Wireless-MUX modules when servicing is required.

Accessories

Connectors as replacement items	Type	Order No.	Pcs. / Pkt.
Shield connector	IB IL SCN-6 SHIELD-TWIN	2740245	5
Connector for the supply (with color print)	IB IL SCN-PWR IN-CP	2727637	10
Connector for input and output terminals	IB IL SCN-8	2726337	10

Antennas as replacement items	Type	Order No.	Pcs. / Pkt.
Omnidirectional antenna	RAD-ISM-2400-ANT-OMNI-2-1	2867461	1
Panel antenna	RAD-ISM-2400-ANT-PAN-8-0	2867610	1



Operation of the wireless system is only permitted if accessories available from Phoenix Contact are used. The use of any other components can lead to withdrawal of the operating license.

You can find the approved accessories for this wireless system listed with the product at phoenixcontact.net/products.

Additional accessories

Recommended end bracket; placed both to the right and left of the module to secure it on the DIN rail	CLIPFIX 35-5	3022276	50
---	--------------	---------	----



Accessories for extending the antenna cable are available on request.

4 Technical data

General data

Housing dimensions with connectors (width x height x depth)	102 mm x 58.5 mm x 120 mm
Weight (one module without antenna)	270 g (with connectors)
Connection method for sensors and actuators	1-wire technology

Housing dimensions

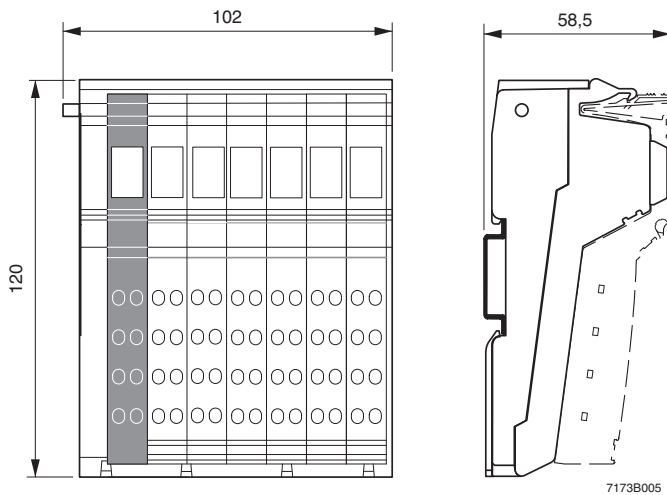

Figure 1 Housing dimensions of the module (mm)

Ambient conditions

Regulations	Developed according to VDE 0160, UL 508
Ambient temperature (operation)	-25°C ... +60°C
Ambient temperature (storage/transport)	-25°C ... +85°C
Humidity (operation)	95%, non-condensing



NOTE: In the range between -25°C ... +60°C, appropriate measures against increased humidity (>85%) must be taken.

Humidity (storage/transport)	95%
------------------------------	-----



For a short period, slight condensation may appear on the outside of the housing if, for example, the module is brought into a closed room from a vehicle.

Air pressure (operation)	80 kPa ... 108 kPa (up to 2000 m above sea level)
Air pressure (storage/transport)	66 kPa ... 108 kPa (up to 3500 m above sea level)
Degree of protection according to IEC 60529	IP20
Protection class according to IEC 61140/VDE 0140-1	Class III
Air clearances and creepage distances	According to IEC 60664/IEC 60664A DIN VDE 0110 and DIN VDE 0160
Housing material	Plastic, PVC-free, PBT, self-extinguishing (V0)
Pollution degree according to EN 60664, EN 61131-2	2; condensation not permitted during operation
Surge voltage class	II

Electrical isolation/isolation of the voltage areas

Common potentials

24 V communications power, 24 V actuator supply, and GND have the same potential. FE is a separate potential area.

Test distance

24 V supply (I/O)/functional earth ground

24 V supply (I/O)/analog channels

Analog channels/FE

Test voltage

500 V AC, 50 Hz, 1 min.

500 V AC, 50 Hz, 1 min.

500 V AC, 50 Hz, 1 min.

Mechanical requirements

Vibration test, sinusoidal vibrations according to IEC 60068-2-29; EN 60068-2-29

5g load, 2.5 hours in each space direction

Shock test according to IEC 60068-2-27; EN 60068-2-27

25g load for 11 ms, half sinusoidal wave, three shocks in each space direction and orientation

Broadband noise according to IEC 60068-2-64; EN 60068-2-64

0.78g load, 2.5 hours in each space direction

Conformance according to EMC directive 89/336/EEC and R&TTE directive 1999/5/EC

Noise immunity test according to EN 61000-6-2

Electrostatic discharge (ESD)

EN 61000-4-2
IEC 61000-4-2

Criterion B
6 kV contact discharge
8 kV air discharge

Electromagnetic fields

EN 61000-4-3
IEC 61000-4-3

Criterion A
Field strength: 10 V/m

Fast transients (burst)

EN 61000-4-4/
IEC 61000-4-4

Criterion B
Remote bus: 2 kV
Power supply: 4 kV
I/O cables: 4 kV

Criterion A
All interfaces: 1 kV

Surge voltage

EN 61000-4-5
IEC 61000-4-5

Criterion B
DC supply lines:
±0.5 kV/±0.5 kV
(symmetrical/asymmetrical)
Signal lines:
±0.5 kV/±0.5 kV
(symmetrical/asymmetrical)

Conducted interference

EN 61000-4-6
IEC 61000-4-6

Criterion A
Test voltage 10 V

Noise emission test according to EN 61000-6-4

Noise emission of housing

EN 55011

Class A (industrial applications)

Check for wireless approval

EMC

ETSI EN 301 489-17

Wireless

ETSI EN 300 328

Safety

EN 60950-1

Health

EN 50371

Wireless interface

Wireless interface	Bluetooth 1.2
Frequency range	2.402 GHz ... 2.480 GHz
Channel distance	1 MHz
Number of channels	79
Modulation	GFSK (Gaussian Frequency Shift Keying)
Maximum transmission power at the antenna connection	14 dBm for ILB BT ADIO MUX-OMNI 8 dBm for ILB BT ADIO MUX-PANEL
Receiver sensitivity	-88 dBm
Antenna connection	MCX socket
Latency	6.8 ms, typical
Wake-up time (establishing the wireless connection)	3.0 s, typical
Failure state time for wireless interruption	≤800 ms

24 V module supply**Communications power**

Nominal voltage	24 V DC
Tolerance	-15%/+20% according to EN 61131-2
Ripple	±5% according to EN 61131-2
Permissible range	19.2 V ... 30.0 V
Current consumption at U_L	75 mA
Protection against polarity reversal	Yes
Surge protection	Yes
Connection	Via power connector

Actuator supply

Nominal voltage	24 V DC
Tolerance	-15%/+20% according to EN 61131-2
Ripple	±5% according to EN 61131-2
Permissible range	19.2 V ... 30.0 V
Current consumption at U_L	≤8 A
Number of potential groups	1
Overload protection	Yes
Protection against polarity reversal	No
Connection	Via power connector

Digital outputs

Number	16
Number of voltage groups	1
Connection method for actuators	1-wire technology
Nominal output voltage U_{OUT}	24 V DC
Differential voltage for I_{nom}	≤1 V
Nominal current I_{nom} per channel	0.5 A
Total current	8 A
Protection	Short circuit; overload
Nominal load	
Ohmic	48 Ω/12 W
Lamp	12 W
Inductive	12 VA (1.2 H, 50 Ω)
Switching frequency with nominal inductive load	0.5 Hz (1.2 H, 50 Ω)
Overload response	Auto restart
Behavior in the event of inductive overload	Output may be damaged
Reverse voltage protection against short pulses	Yes
Resistance to permanently applied reverse voltages	Yes, maximum permissible current 2 A
Response upon power down	The output follows the supply voltage without delay.

Digital outputs [...]

Limitation of the voltage induced on circuit interruption	-41 V
Single maximum energy in freewheeling	≤1 J
Protective circuit type	Integrated freewheeling circuit in the output chip
Overcurrent shutdown	At 0.7 A, minimum
Maximum output current when switched off	10 µA



When not loaded, a voltage can be measured even at an output that is not set.

Digital inputs

Number	16
Connection method for sensors	1-wire technology
Input design	According to EN 61131-2 Type 1
Definition of switching thresholds	
Maximum low-level voltage	$U_{Lmax} < 5 V$
Minimum high-level voltage	$U_{Hmin} > 15 V$
Common potentials	Ground
Nominal input voltage U_{IN}	24 V DC
Permissible range	$-30 V < U_{IN} < +30 V$ DC
Nominal input current at U_{IN}	3.6 mA per channel, typical
Current flow	Linear in the range $1 V < U_{IN} < 30 V$
Delay time	≤300 µs
Permissible cable length to sensor	100 m
Use of AC sensors	AC sensors in the voltage range $< U_{IN}$ are limited in application

Typical power dissipation with 24 V supply voltage

Formula for calculating the power dissipation of the electronics

$$P_{TOT} = 0.552 W + \sum_{n=0}^{16} (0.065 W + I_{Ln}^2 \times 0.28 \Omega) + \sum_{m=0}^{16} 0.086 W + \sum_{l=0}^2 0.372 W + \sum_{k=0}^2 0.044 W$$

Where:

- P_{TOT} Total power dissipation in the module
- n Index of the number of set digital outputs ($n = 0 \dots 16$)
- I_{Ln} Load current of output n
- m Index of the number of set digital inputs ($m = 0 \dots 16$)
- l Index of the number of analog outputs used ($l = 0 \dots 2$)
- k Index of the number of analog inputs used ($k = 0 \dots 2$)

Tolerance and temperature response of the analog channels

An analog channel consists of an input and output. The tolerance values refer to the measuring range final value, including all tolerances of the input and output.

Tolerances at $T_A = +23^\circ\text{C}$

Measuring range	Absolute (typical)	Absolute (maximum)	Relative (typical)	Relative (maximum)
0 V ... 10 V	± 60 mV	± 120 mV	$\pm 0.60\%$	$\pm 1.20\%$
0 mA ... 20 mA	± 130 μA	± 240 μA	$\pm 0.65\%$	$\pm 1.20\%$

Temperature and drift response

Drift in reference to the measuring range final value

Measuring range	$T_A = -25^\circ\text{C} \dots +23^\circ\text{C}$ typical	$T_A = -25^\circ\text{C} \dots +23^\circ\text{C}$ maximum	$T_A = +23^\circ\text{C} \dots +60^\circ\text{C}$ typical	$T_A = +23^\circ\text{C} \dots +60^\circ\text{C}$ maximum
0 V ... 10 V	600 ppm/K	800 ppm/K	210 ppm/K	340 ppm/K
0 mA ... 20 mA	600 ppm/K	800 ppm/K	210 ppm/K	340 ppm/K

Additional tolerances influenced by electromagnetic fields

Type of electromagnetic interference	Typical deviation of the measuring range final value (voltage and current channels)	
	Relative	
Electromagnetic fields; field strength 10 V/m according to EN 61000-4-3/IEC 61000-4-3	$< \pm 4\%$	
Conducted interference Class 3 (test voltage 10 V) according to EN 61000-4-6/IEC 61000-4-6	$< \pm 0.5\%$	
Fast transients (burst), 4 kV supply, 2 kV input according to EN 61000-4-4/IEC 61000-4-4	$< \pm 0.5\%$	

5 Usage notes

**WARNING:**

The use of products described in this data sheet is oriented exclusively to electrically skilled persons or persons instructed by them, who are familiar with applicable national standards and other regulations regarding electrical engineering and, in particular, the relevant safety concepts. Phoenix Contact accepts no liability for erroneous handling or damage to products from Phoenix Contact or third-party products resulting from disregard of information contained in this data sheet.



This device meets the basic requirements and additional corresponding specifications of directive 1999/5/EU.



Please note the maximum permissible transmission power for your country.

This device complies with R&TTE device class 1, with the following restrictions on use according to ERC recommendation 70-03:

Norway The device must not be operated within 20 km of the Ny Ålesund town center.



Operation of the wireless system is only permitted if accessories available from Phoenix Contact are used. The use of any other components can lead to withdrawal of the operating license.

You can find the approved accessories for this wireless system listed with the product at phoenixcontact.net/products.



This device contains:

FCC ID: PVH071902

IC: 5325A-0719X

This device complies with Part 15 of the FCC Rules. Operation is subject to the following two conditions:

- (1) this device may not cause harmful interference, and
- (2) this device must accept any interference received, including interference that may cause undesired operations.

6 Local diagnostics and status indicators

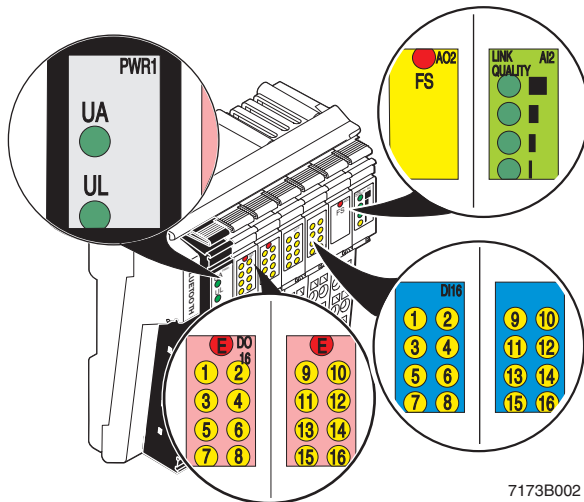

7173B002

Figure 2 Diagnostics and status indicators of the ILB BT ADIO MUX module



Observe the LINK QUALITY display during the startup phase to ensure a high transmission speed. When choosing the mounting location and distance between antennas, antennas should be installed so that at least 3 (ideally 4) LEDs are permanently lit in the LINK QUALITY display.

Depending on the system, occasional fluctuations in the LINK QUALITY may occur during operation.

Designation	Color	Meaning
PWR		
UA	Green	24 V actuator supply
UL	Green	24 V communications power
OUT		
E	Red	Short circuit or overload at one of the outputs
1 ... 16	Yellow	Output status indicators
IN		
1 ... 16	Yellow	Input status indicators
FS		
FS	Red	Failure state, wireless connection interrupted, analog and digital outputs set to 0
LINK QUALITY		
LQ	Green	Quality of Bluetooth connection (bit error rate; BER)
	4 LEDs	BER 0% ... 0.05%
	3 LEDs	BER 0.05% ... 1%
	2 LEDs	BER 0.1% ... 1.7%
	1 LED	BER > 1.7%
	OFF	No Bluetooth connection established



NOTE: Device damage

If the error LED (E) of a group of 16 outputs lights up (e.g., connector 2 and connector 3), this indicates that a short circuit or overload is present at one or more of the outputs in this group.

7 Connecting the supply, actuators, and sensors

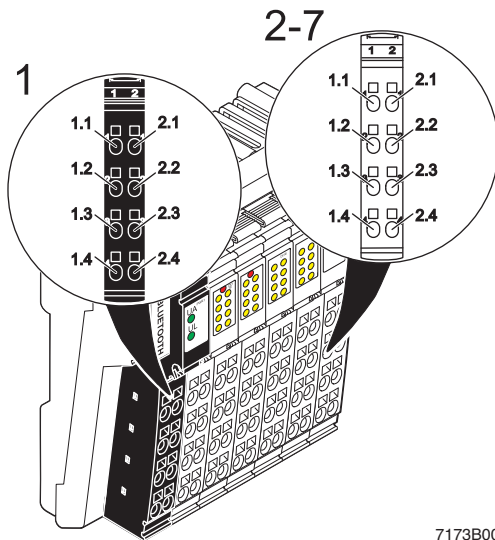

7173B003

Figure 3 Terminal point assignment of the connectors



NOTE: Device damage

The terminal points for GND and U_L can have a total current of 8 A per terminal point. The maximum current carrying capacity of 8 A must not be exceeded.



The feeding points have the same ground potential. All ground supplies on a module are electrically connected with one another.

The communications power is also electrically connected via all contacts. In this way, it can supply all potentials with just one supply without the need for additional terminals, see "Connection example for the supply" on page 15.

7.1 Terminal point assignment of the power connector

Terminal point	Assignment
Connector 1 (PWR)	
1.1, 2.1	24 V actuator supply U_A
1.2, 2.2	24 V communications power U_L
1.3, 2.3	GND
1.4, 2.4	FE

7.2 Terminal point assignment of the digital output and input connectors

Connector 2 (OUT1)				Connector 3 (OUT2)				Connector 4 (IN1)				Connector 5 (IN2)			
1.1	O1	2.1	O2	1.1	O9	2.1	O10	1.1	I1	2.1	I2	1.1	I9	2.1	I10
1.2	O3	2.2	O4	1.2	O11	2.2	O12	1.2	I3	2.2	I4	1.2	I11	2.2	I12
1.3	O5	2.3	O6	1.3	O13	2.3	O14	1.3	I5	2.3	I6	1.3	I13	2.3	I14
1.4	O7	2.4	O8	1.4	O15	2.4	O16	1.4	I7	2.4	I8	1.4	I15	2.4	I16

7.3 Terminal point assignment of the analog output connector

Connector 6 (analog OUT)				
1.1	+U1, voltage output, channel 1		2.1	+U2, voltage output, channel 2
1.2	+I1, current output, channel 1		2.2	+I2, current output, channel 2
1.3	AGND, analog ground		2.3	AGND, analog ground
1.4	Shield connection		2.4	Shield connection

7.4 Terminal point assignment of the analog input connector

Connector 7 (analog IN)				
1.1	+U1, voltage input, channel 1		2.1	+U2, voltage input, channel 2
1.2	+I1, current input, channel 1		2.2	+I2, current input, channel 2
1.3	AGND, analog ground		2.3	AGND, analog ground
1.4	Shield connection		2.4	Shield connection

9 Connection example



The numbers above the module illustration identify the connector slots.

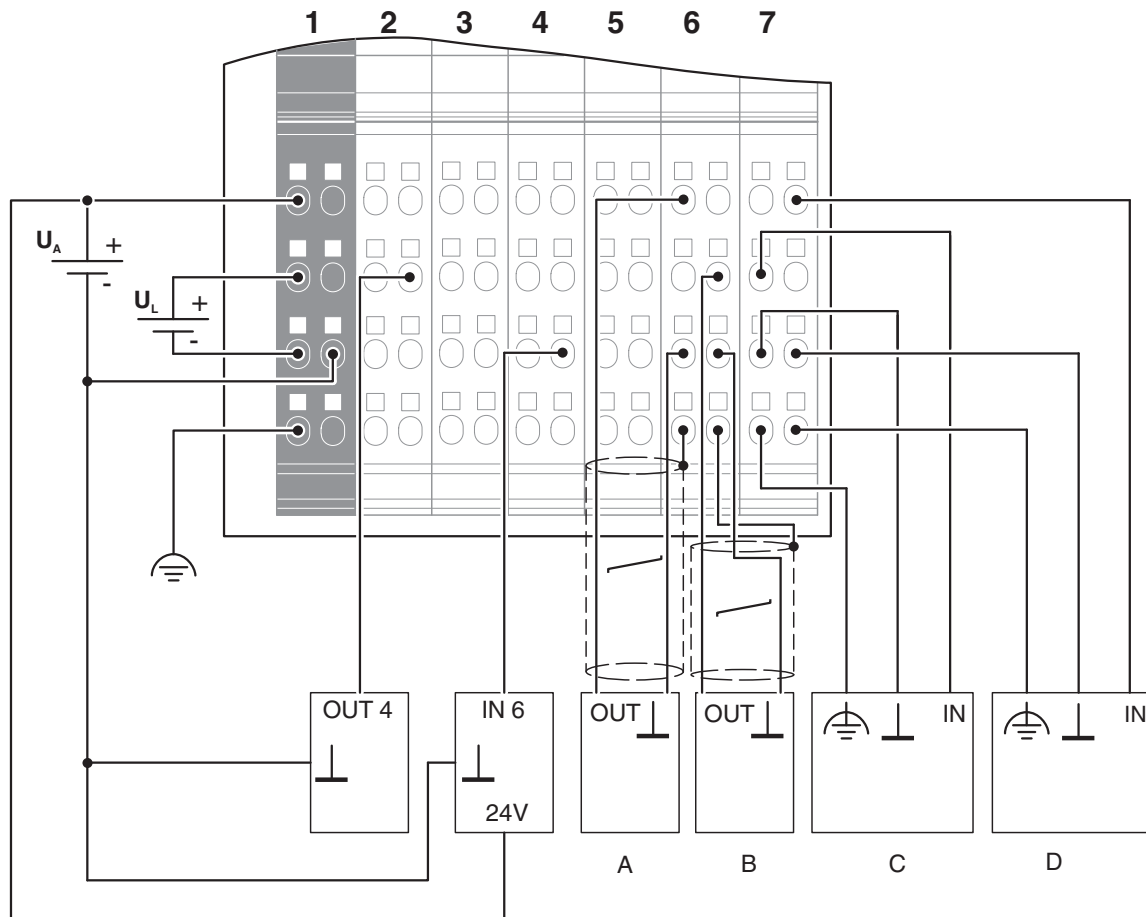

7153B004

Figure 5 Connection example for the supply

Key:

- A: Actuator at the voltage output (channel 1)
- B: Actuator at the current output (channel 2)
- C: Active sensor with current output (channel 1)
- D: Active sensor with voltage output (channel 2)

10 Assignment of terminal points to the remote station

Master	Slot	4 (IN)								5 (IN)							
	Terminal point	1.1	2.1	1.2	2.2	1.3	2.3	1.4	2.4	1.1	2.1	1.2	2.2	1.3	2.3	1.4	2.4
	LED	1	2	3	4	5	6	7	8	1	2	3	4	5	6	7	8
Slave	Slot	2 (OUT)								3 (OUT)							
	Terminal point	1.1	2.1	1.2	2.2	1.3	2.3	1.4	2.4	1.1	2.1	1.2	2.2	1.3	2.3	1.4	2.4
	LED	1	2	3	4	5	6	7	8	1	2	3	4	5	6	7	8

Slave	Slot	4 (IN)								5 (IN)							
	Terminal point	1.1	2.1	1.2	2.2	1.3	2.3	1.4	2.4	1.1	2.1	1.2	2.2	1.3	2.3	1.4	2.4
	LED	1	2	3	4	5	6	7	8	1	2	3	4	5	6	7	8
Master	Slot	2 (OUT)								3 (OUT)							
	Terminal point	1.1	2.1	1.2	2.2	1.3	2.3	1.4	2.4	1.1	2.1	1.2	2.2	1.3	2.3	1.4	2.4
	LED	1	2	3	4	5	6	7	8	1	2	3	4	5	6	7	8

Master	Slot	7 (analog IN)			
	Terminal point	1.1	2.1	1.2	2.2
Slave	Slot	6 (analog OUT)			
	Terminal point	1.1	2.1	1.2	2.2

Slave	Slot	7 (analog IN)			
	Terminal point	1.1	2.1	1.2	2.2
Master	Slot	6 (analog OUT)			
	Terminal point	1.1	2.1	1.2	2.2

11 Diagnostics

11.1 Error table with status indicators

Error type	Status indicators
Communications power U_L not present	UL LED is OFF
Sensor supply U_A too low	UA LED is OFF
Short circuit of a digital output	E LED of the affected output group lights up red
Wireless connection aborted	FS LED is ON

12 Antennas

The aim of Phoenix Contact wireless transmission solutions is to provide users with the simplest possible access to the wireless transmission medium.

This explanation of the complex area of antenna technology will therefore be kept as simple as possible. However, in order to build reliable systems, a few basic properties of antenna technology must be taken into account.

12.1 Antenna alignment

When installing two antennas, it is generally desirable to have a line of sight between them wherever possible, as any obstacles between the antennas will adversely affect the connection.

The Fresnel zone, which extends around the direct connecting line between transmitting and receiving antennas, should also be taken into account. If this zone is disturbed by any obstacles or the terrain, this will adversely affect the wireless connection.

Figure 6 illustrates an ideal installation with undisturbed connection.

In Figure 7, the Fresnel zone is adversely affected by the terrain. The low height of the antenna masts still allows for a line of sight, but the Fresnel zone is not completely clear.

In Figure 8, the connection is attenuated by obstacles in the Fresnel zone, even though there is a line of sight.

The radius of the Fresnel zone depends on the transmission frequency and the distance between the transmitting and receiving antennas.

The radius R corresponds to the minimum height of the antenna mast (if the terrain is flat). For a 2.4 GHz system, the mast height R/m , depending on the distance to be covered D/m , is given in the characteristic curve in Figure 9.

Example (Figure 9):

For a distance of 100 m, the antenna should be installed at a minimum height of 1.80 m to provide a clear Fresnel zone.

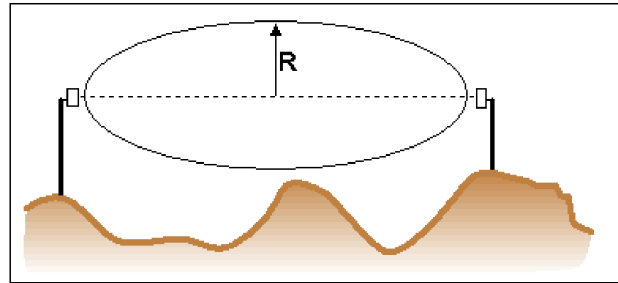

Figure 6 Ideal antenna installation

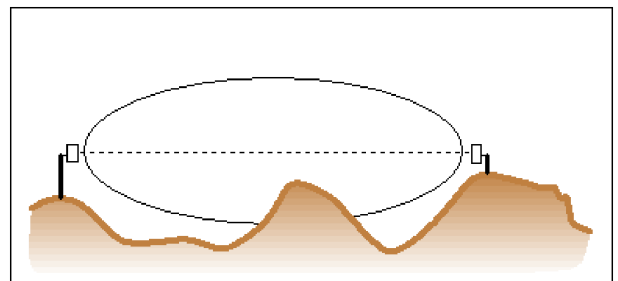

Figure 7 Fresnel zone adversely affected by the terrain

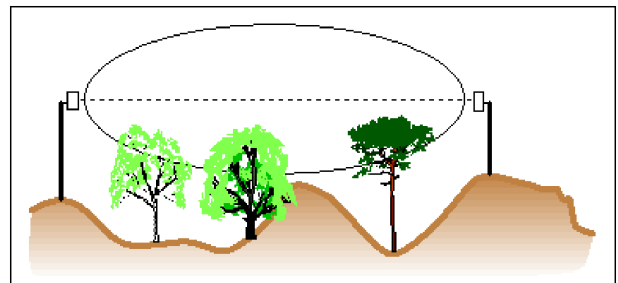

Figure 8 Fresnel zone adversely affected by obstacles

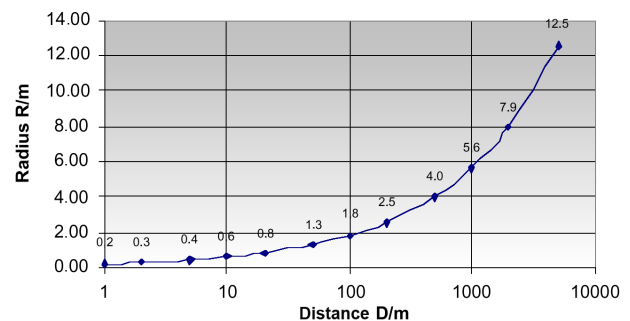

Figure 9 Radius R of the Fresnel zone over distance D

12.2 Omnidirectional antennas

Omnidirectional antennas, also known as rod or omni antennas (Figure 10), are usually used if the position between the transmitter and receiver can change. This is true for moving applications or, for example, for creating multiple receiver systems where the transmitter sends the signal in several directions. The use of omnidirectional antennas is also recommended for applications with **no line of sight** because the signal then travels from the transmitter to the receiver via reflections, and their path and direction cannot be predicted.

The ideal installation location is the top of a mast or on a control cabinet so that the antenna has the greatest possible free space in all directions.

Unfortunately, it is not always possible to mount the antenna in these locations. If an omnidirectional antenna is mounted on the side of a mast, specific measurements and distances must be observed.

The mast or control cabinet (usually made from a conductive material) also affects the directional characteristics of the antenna. Both the mast diameter and the distance of the antenna from the mast influence the resulting directional characteristics.

An omnidirectional antenna that is mounted on the top of the mast or projects over the edge of a control cabinet usually has almost uniform directional characteristics over 360° on the horizontal plane (see Figure 11).

If the same antenna is mounted on the side of an aluminum or steel mast or does not project over the side of a control cabinet, the directional characteristics may change considerably depending on the mast diameter or width of the side surface D and the distance C between the mast or side surface and the antenna. The two examples given here are for a 2.4 GHz system:

In Figure 12 (1), the omnidirectional antenna acts as an antenna with a preferred direction.

In Figure 12 (2), the range is also considerably shorter on the side facing away from the mast. This type of installation could have an unexpectedly poor result.

Key to Figure 12:

	1	2
A	Antenna	Antenna
B	Mast/surface (diameter/width D)	Mast/surface (diameter/width D)
C	Antenna distance (C = 3 cm)	Antenna distance (C = 6 cm)



Figure 10 Omnidirectional antenna with cable

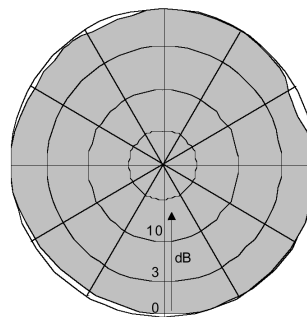

Figure 11 Uniform directional characteristics

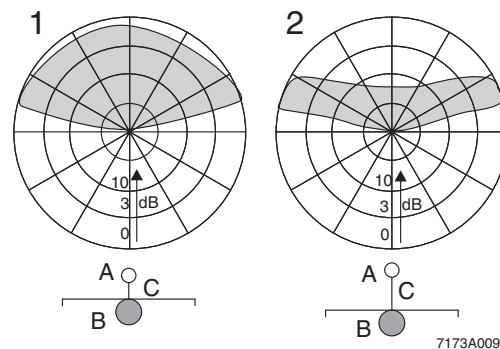

Figure 12 Antenna with preferred direction (1) and antenna with substantially reduced range (2)

Observe the LINK QUALITY display during the startup phase to ensure a high transmission speed. When choosing the mounting location and distance between antennas, antennas should be installed so that at least 3 (ideally 4) LEDs are permanently lit in the LINK QUALITY display.

Depending on the system, occasional fluctuations in the LINK QUALITY may occur during operation.

Technical data for the RAD-ISM-2400-ANT-OMNI-2-1 omnidirectional antenna (Order No. 2867461)

Temperature range	-20°C ... +65°C
Degree of protection	IP65
Impedance	50 Ω
Gain	2 dBi
Cable length	1.5 m
Connection	MCX (connector)
Apex angle, horizontal	360°
Apex angle, vertical	75°
VSWR	≤2.0

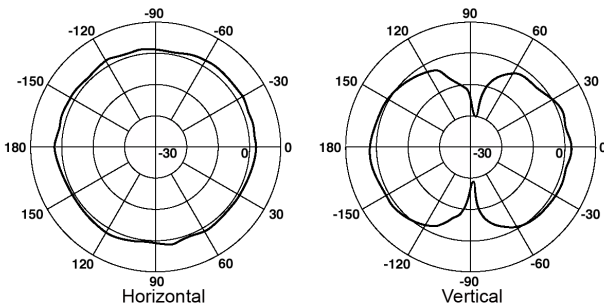

Figure 13 Directional characteristics of an omnidirectional antenna

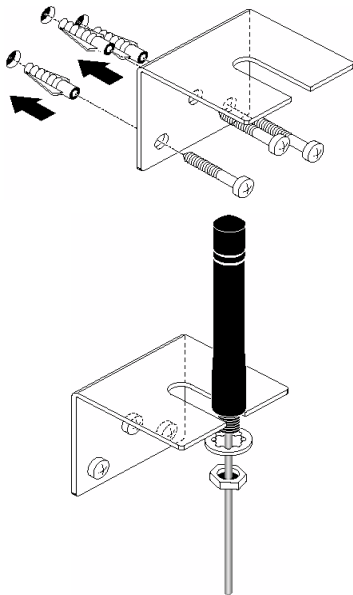

Figure 14 Wall mounting

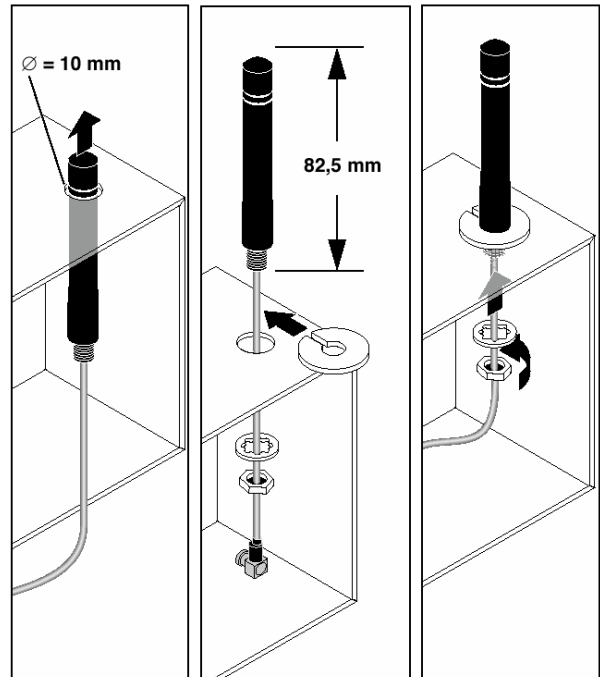

Figure 15 Hole mounting

12.3 Panel antennas

Panel antennas emit the transmission power in a preferred direction. This leads to a range gain (similar to the effect of the reflector in a flashlight). The existing transmission power is therefore not amplified, but simply focused. The same applies for the receiving end. A panel antenna receives signals specifically from the "area" that it is directed at.

The use of a panel antenna is recommended when covering large distances **with a line of sight**.



Figure 16 Panel antenna with accessories

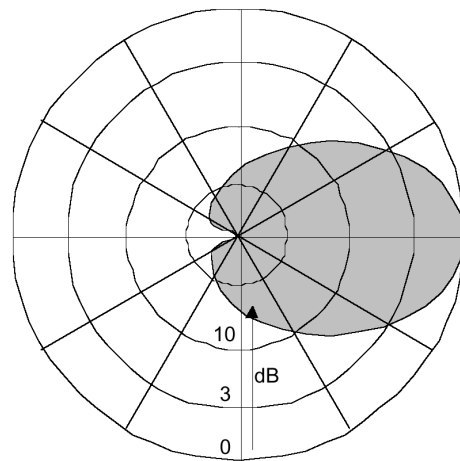
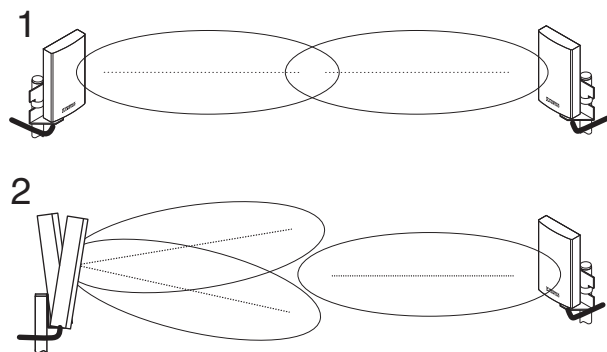

Figure 17 Directional characteristics of a panel antenna

With panel antennas, it is particularly important to ensure that the antenna is properly secured. An unstable antenna may "sway" or "wobble" in strong winds, which over long distances can move the transmitter or receiver beam out of its target area (Figure 18 (2)).



7173A008

Figure 18 Correct transmitter and receiver beam (1); transmitter and receiver beam outside the target area (2)

Technical data for the RAD-ISM-2400-ANT-PAN-8-0 panel antenna (Order No. 2867610)

Temperature range	-40°C ... +80°C
Degree of protection	IP55
Impedance	50 Ω
Gain	8 dBi
Dimensions (height x width x depth)	101 mm x 80 mm x 20 mm
Connection	SMA (socket)
Wind load	15 N at 160 km/h
Apex angle, horizontal	75°
Apex angle, vertical	70°
VSWR	1.5

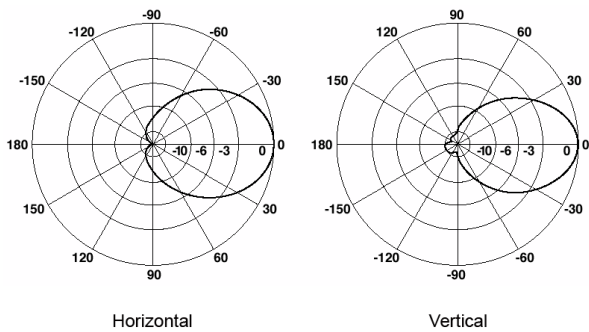

Figure 19 Directional characteristics

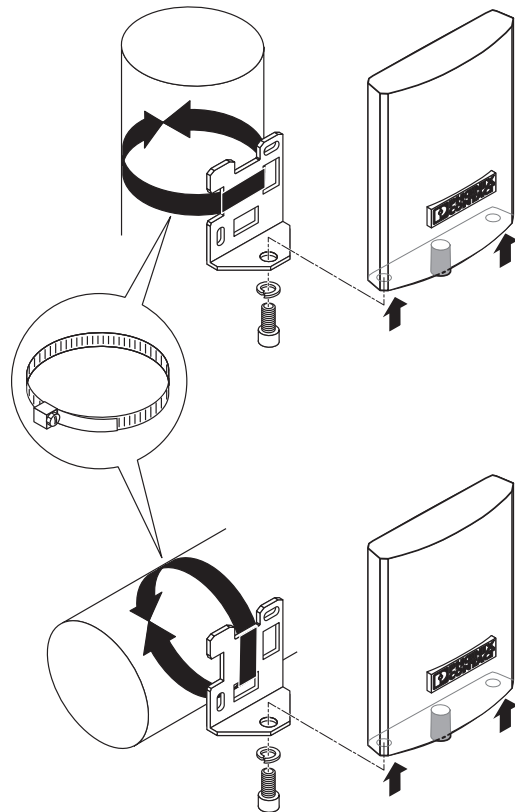

Figure 21 Tube mounting

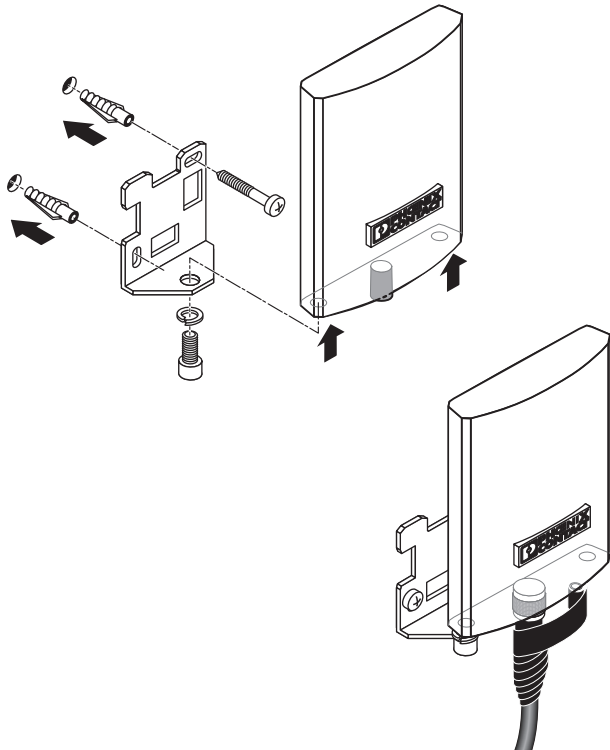

Figure 20 Wall mounting



NOTE: Device damage

Protect the SMA connection with sealing tape (see Figure 20).