

Specification RW-2536

Document Number: 108-121035

ZHD-SCE

2:1 Shrink Ratio

Heat Shrinkable Identification Sleeve

SCOPE

This quality assurance specification establishes the quality standard for heat shrinkable identification markers, for use in applications where low fire hazard characteristics are critical along with excellent fluid resistance and physical properties. These special requirements are detailed in section 7.

The operating temperature for this product is -55°C to + 125°C.

ZHD-SCE is a Zero Halogen, Diesel Resistant, Heat Shrink, Identification Sleeve. This product meets Rail Standards EN 50343 Appendix H and EN45545-2 requirement set R22/R23, hazard level classification 1 and 2. This requirement set and hazard rating allows use of this product with specific rail car designs and operating categories in Europe.

The ZHD-SCE system is an automatic method of identifying items, which are permanent upon printing.

The marker system comprises specific printers and ribbons (refer to Identification Printer Product Ribbon Matrix Document 411-121005). Compliance to this specification can only be guaranteed if TE Connectivity approved printers and ribbons are used.

This product is laser markable using industry standard YAG lasers.

The tube size for qualification testing is 6.4mm as supplied internal diameter unless otherwise specified.

Approved Signatories:

This document is electronically reviewed and approved by TE Connectivity.

TE CONNECTIVITY, SWINDON, UK

While TE Connectivity has made every reasonable effort to ensure the accuracy of the information in this specification, TE Connectivity does not guarantee that it is error-free, nor does TE Connectivity make any other representation, warranty or guarantee that the information is accurate, correct, reliable or current. TE Connectivity reserves the right to make any adjustments to the information contained herein at any time without notice. TE Connectivity expressly disclaims all implied warranties regarding the information contained herein, including, but not limited to, any implied warranties of merchantability or fitness for a particular purpose. The dimensions in this document are for reference purposes only and are subject to change without notice. Specifications are subject to change without notice. Consult TE Connectivity for the latest dimensions and design specifications.

If this document is printed it becomes uncontrolled.

1. REQUIREMENTS

1.1 Composition, appearance and colour

The marker shall be fabricated from low fire hazard (LFH), irradiated, thermally stabilized modified polyolefin compound. It shall be homogeneous and essentially free from flaws, defects, pinholes, bubbles, seams, cracks or inclusions.

The markers shall be Orange, Yellow, Green, Blue, White or Red

1.2 Dimensions

The product shall be supplied in the format as shown in figure 1 and to the dimensions of Table 1

Figure 1. ZHD-SCE format

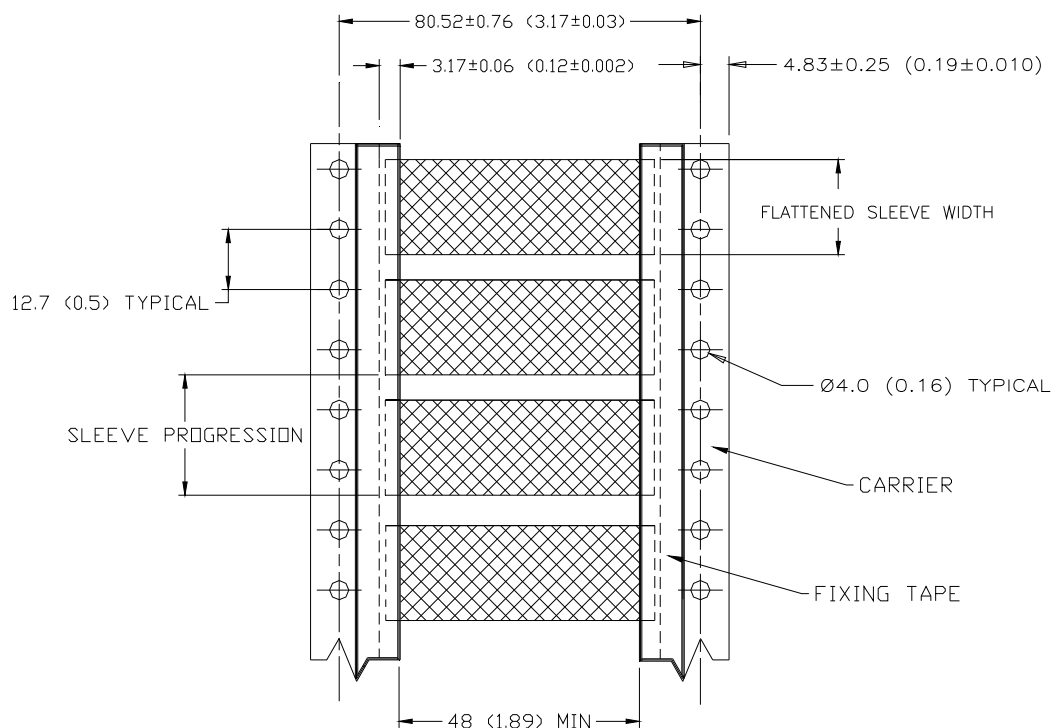

Dimensions in mm (inches)

TE CONNECTIVITY, SWINDON, UK

While TE Connectivity has made every reasonable effort to ensure the accuracy of the information in this specification, TE Connectivity does not guarantee that it is error-free, nor does TE Connectivity make any other representation, warranty or guarantee that the information is accurate, correct, reliable or current. TE Connectivity reserves the right to make any adjustments to the information contained herein at any time without notice. TE Connectivity expressly disclaims all implied warranties regarding the information contained herein, including, but not limited to, any implied warranties of merchantability or fitness for a particular purpose. The dimensions in this document are for reference purposes only and are subject to change without notice. Specifications are subject to change without notice. Consult TE Connectivity for the latest dimensions and design specifications.

If this document is printed it becomes uncontrolled.

Figure 2. Heat Shrink Product in as Supplied “D” and fully Recovered State “d”, with recovered wall “w”.

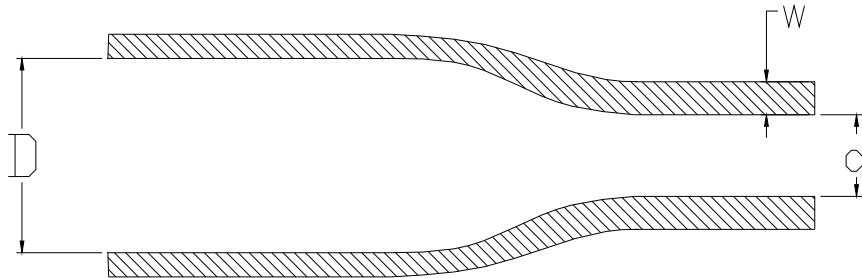

Table 1: Product Dimensions for ZHD-SCE

Part Description	Minimum Supplied Inside Diameter (D) mm (inches)	Maximum Recovered Inside Diameter (d) mm (inches)	Wall Thickness After Recovery (w) mm (inches)	Minimum Sleeve Flattened Width mm (inches)	Sleeve Progression mm (inches)	Nominal Weight of single sleeve (~50mm long) g
ZHD-SCE-2.4	2.40 (0.094)	1.19 (0.047)	0.50 ± 0.010 (0.020 ± 0.004)	4.9 (0.194)	12.70 ± 0.63 (0.500 ± 0.025)	0.17
ZHD-SCE-3.2	3.20 (0.126)	1.6 (0.063)	0.50 ± 0.010 (0.020 ± 0.004)	6.5 (0.256)	12.70 ± 0.63 (0.500 ± 0.025)	0.21
ZHD-SCE-4.8	4.80 (0.189)	2.4 (0.094)	0.51 ± 0.11 (0.020 ± 0.004)	8.9 (0.35)	12.70 ± 0.76 (0.500 ± 0.030)	0.30
ZHD-SCE-6.4	6.35 (0.250)	3.2 (0.126)	0.65 ± 0.15 (0.026 ± 0.006)	11.0 (0.430)	16.94 ± 0.89 (0.667 ± 0.035)	0.50
ZHD-SCE-9.5	9.50 (0.374)	4.8 (0.189)	0.65 ± 0.15 (0.026 ± 0.006)	15.7 (0.618)	25.40 ± 0.89 (1.000 ± 0.035)	0.80
ZHD-SCE-12.7	12.70 (0.500)	6.4 (0.250)	0.65 ± 0.15 (0.026 ± 0.006)	20.7 (0.815)	29.64 ± 1.02 (1.167 ± 0.040)	1.0
ZHD-SCE-19.0	19.05 (0.750)	9.5 (0.374)	0.75 ± 0.15 (0.030 ± 0.006)	30.7 (1.21)	42.34 ± 1.02 (1.667 ± 0.040)	2.0
ZHD-SCE-25.4	25.40 (1.0)	12.7 (0.500)	0.90 ± 0.15 (0.035 ± 0.006)	41.1 (1.62)	50.80 ± 1.02 (2.000 ± 0.040)	3.0
ZHD-SCE-38.1	38.10 (1.5)	19.1 (0.750)	1.00 ± 0.20 (0.039 ± 0.008)	61.0 (2.40)	72.00 ± 1.02 (2.833 ± 0.040)	5.0

TE CONNECTIVITY, SWINDON, UK

While TE Connectivity has made every reasonable effort to ensure the accuracy of the information in this specification, TE Connectivity does not guarantee that it is error-free, nor does TE Connectivity make any other representation, warranty or guarantee that the information is accurate, correct, reliable or current. TE Connectivity reserves the right to make any adjustments to the information contained herein at any time without notice. TE Connectivity expressly disclaims all implied warranties regarding the information contained herein, including, but not limited to, any implied warranties of merchantability or fitness for a particular purpose. The dimensions in this document are for reference purposes only and are subject to change without notice. Specifications are subject to change without notice. Consult TE Connectivity for the latest dimensions and design specifications.

If this document is printed it becomes uncontrolled.

2. TEST REQUIREMENTS

This specification details the requirements for the ZHD-SCE. Section 6 lists the general tests for Identification products and section 7 lists the specific tests which reflect the performance enhancements of ZHD-SCE.

3. RELATED DOCUMENTS

3.1 Identification Engineering Work Instructions IEWI

TE Doc. Number	TE reference	TE Title	Complies with
109-121002	IEWI-002	Tensile Strength and Ultimate Elongation at 23°C	ASTM D2671 (section 44-48) ASTM D142
109-121003	IEWI-003	Dimensions	ASTM D2671 (section 8-13) ASTM D876
109-121005	IEWI-005	Dielectric Strength	ASTM D2671 (section 20-25) ASTM D149
109-121006	IEWI-006	Low Temperature Flexibility	ASTM D2671 (section 36-43) Procedure C BS EN 60684-3-216
109-121007	IEWI-007	Heat Shock	SAE-AS-23053 ASTM D2671 (section 26-30)
109-121008	IEWI-008	Heat Resistance	SAE-AS-23053 ASTM D2671 (section 49-54)
109-121009	IEWI-009	Copper Mirror Corrosion	ASTM D2671 (section 93 procedure A)
109-121012	IEWI-012	Print Permanence Testing using the Mechanical Crockmeter	SAE AS5942 (section 4.1)
109-121013	IEWI-013	Fluid Resistance (Elevated Temperature under Re-flux)	
109-121015	IEWI-015	Specific Gravity	ASTM 2671 (section 73-74) ASTM D792
109-121016	IEWI-016	Water Absorption	ASTM D2671 (section 79-80) ASTM D570
109-121017	IEWI-017	Volume Resistivity	ASTM D2671 (section 75-78) ASTM D257
109-121021	IEWI-021	UV Testing	ASTM G154
109-121029	IEWI-029	Fluid Resistance (Elevated Temperature in Ovens)	
109-121031	IEWI-031	Split Testing	
109-121039	IEWI-039	Room Temperature Fluid Testing	
109-121046	IEWI-046	Thermal Cycling	
109-121052	IEWI-052	External Test House Matrix	
109-121054	IEWI-054	Oxygen Index	BS EN ISO 4589-1

TE CONNECTIVITY, SWINDON, UK

While TE Connectivity has made every reasonable effort to ensure the accuracy of the information in this specification, TE Connectivity does not guarantee that it is error-free, nor does TE Connectivity make any other representation, warranty or guarantee that the information is accurate, correct, reliable or current. TE Connectivity reserves the right to make any adjustments to the information contained herein at any time without notice. TE Connectivity expressly disclaims all implied warranties regarding the information contained herein, including, but not limited to, any implied warranties of merchantability or fitness for a particular purpose. The dimensions in this document are for reference purposes only and are subject to change without notice. Specifications are subject to change without notice. Consult TE Connectivity for the latest dimensions and design specifications.

If this document is printed it becomes uncontrolled.

3.2. Reference Documents

ASTM D2671: 1999	Standard Test Methods for Heat-Shrinkable Tubing for Electrical Use
ASTM G 154:	Standard Practice for Operating Fluorescent Ultraviolet (UV) Lamp Apparatus for Exposure of Non-metallic Materials
ASTM E162	Standard Test Method for Surface Flammability of Materials Using a Radiant Heat Energy Source
ASTM E662	Standard Test Method for Specific Optical Density of Smoke Generated by Solid Materials
ASTM E1354	Standard Test Method for Heat and Visible Smoke Release Rates for Materials and Products Using an Oxygen Consumption Calorimeter
BS 6853:1999	Code of practice for fire precautions in the design and construction of passenger carrying trains
IEC 60684-2: 1997	Flexible Insulating Sleeving - Part 2: Methods of Test
BS EN 60684-3-216	Flexible Insulating Sleeving - Part 3: Methods of Test
BS EN 50343: 2014	Railway applications. Rolling stock. Rules for installation of cabling
BS EN ISO 4589-2: 1996	Plastics – Determination of Burning Behaviour by Oxygen Index - Part 2: Ambient Temperature Test
NF X 70 – 100: 1986	Fire Tests Analysis of Pyrolysis and Combustion Gases Tube Furnace Method
NF F 00-608	General Railway Equipment
EN 45545-2	Railway Applications- Fire Protection on Railway Vehicles
SAE AS5942	Marking Of Electrical Insulating Materials
TE Doc. No: 411-121002	TE Connectivity Print Contrast Reference Scale
TE Doc. No: 411-121005	TE Identification Printer Product Ribbon Matrix
TE Doc. No: 411-121008	Installation of Heatshrink Sleeves
(Subsequent amendments to, or revisions of, any of the above publications apply to this standard only when incorporated in it by updating or revision.)	

TE CONNECTIVITY, SWINDON, UK

While TE Connectivity has made every reasonable effort to ensure the accuracy of the information in this specification, TE Connectivity does not guarantee that it is error-free, nor does TE Connectivity make any other representation, warranty or guarantee that the information is accurate, correct, reliable or current. TE Connectivity reserves the right to make any adjustments to the information contained herein at any time without notice. TE Connectivity expressly disclaims all implied warranties regarding the information contained herein, including, but not limited to, any implied warranties of merchantability or fitness for a particular purpose. The dimensions in this document are for reference purposes only and are subject to change without notice. Specifications are subject to change without notice. Consult TE Connectivity for the latest dimensions and design specifications.

If this document is printed it becomes uncontrolled.

4. SAMPLING

Tests shall be carried out on samples taken at random from a batch of product. A batch of markers is defined as that quantity of tubing extruded at any one time.

Testing frequency shall be production routine or qualification.

Production routine tests consisting of visual examination, dimensions, print quality and adherence of marking shall be carried out on every batch of product.

5. PACKAGING

Packaging shall be in accordance with good commercial practice. Each package shall bear an identification label showing material quantity, description, size, color and batch number. Additional information shall be supplied as specified in the contract or order.

TE CONNECTIVITY, SWINDON, UK

While TE Connectivity has made every reasonable effort to ensure the accuracy of the information in this specification, TE Connectivity does not guarantee that it is error-free, nor does TE Connectivity make any other representation, warranty or guarantee that the information is accurate, correct, reliable or current. TE Connectivity reserves the right to make any adjustments to the information contained herein at any time without notice. TE Connectivity expressly disclaims all implied warranties regarding the information contained herein, including, but not limited to, any implied warranties of merchantability or fitness for a particular purpose. The dimensions in this document are for reference purposes only and are subject to change without notice. Specifications are subject to change without notice. Consult TE Connectivity for the latest dimensions and design specifications.

If this document is printed it becomes uncontrolled.

6. GENERAL TESTS FOR IDENTIFICATION PRODUCTS				
6.1. Physical				
	PROPERTY	TEST METHOD	UNITS	REQUIREMENTS
	Visual Examination		---	RW-2536 Section 1.1
	Dimensions 5 min at 150°C	IEWI-003	mm (inch)	In accordance with Table 1 & 2,
	Longitudinal Change	IEWI-003	%	± 20
	Tensile Strength Speed 100mm/min	IEWI-002	MPa (psi)	7 (1015) minimum
	Ultimate Elongation Speed 100mm/min	IEWI-002	%	200 minimum
	Specific Gravity	IEWI-015	g/cm ³	1.40 nominal
	Split testing	IEWI-031	%	100 pass
6.2. Thermal				
	Heat Resistance 168hr 135°C Mandrel Bend Mark Adherence	IEWI-008 IEWI-012	---	No damage to the marker and print legible after 20 rubs. Minimum Print Contrast 3
	Heat Shock 4hr at 175°C Mandrel Bend Mark Adherence	IEWI-007 IEWI-012	---	No damage to the marker and print legible after 20 rubs. Minimum Print Contrast 3
	Thermal Cycling 4 cycles of 1hr at -55°C and 1hr 125°C Mandrel Bend Mark Adherence	IEWI-046 IEWI-012	---	No damage to the marker and print legible after 20 rubs. Minimum Print Contrast 3
	Low Temperature Flexibility 4hr at -55°C Mandrel Bend Mark Adherence	IEWI-006 (Appendix 1) IEWI-012	---	No damage to the marker and print legible after 20 rubs. Minimum Print Contrast 3
6.3. Electrical				
	Dielectric Strength	IEWI-005	MV/m	15 minimum
	Volume Resistivity	IEWI-017	Ohm cm	10 ¹² minimum

TE CONNECTIVITY, SWINDON, UK

While TE Connectivity has made every reasonable effort to ensure the accuracy of the information in this specification, TE Connectivity does not guarantee that it is error-free, nor does TE Connectivity make any other representation, warranty or guarantee that the information is accurate, correct, reliable or current. TE Connectivity reserves the right to make any adjustments to the information contained herein at any time without notice. TE Connectivity expressly disclaims all implied warranties regarding the information contained herein, including, but not limited to, any implied warranties of merchantability or fitness for a particular purpose. The dimensions in this document are for reference purposes only and are subject to change without notice. Specifications are subject to change without notice. Consult TE Connectivity for the latest dimensions and design specifications.

If this document is printed it becomes uncontrolled.

6.4.	Chemical			
	PROPERTY	TEST METHOD	UNITS	REQUIREMENTS
	Copper Mirror Corrosion 16hr at 175°C	IEWI-009	%	8 maximum
	Water Absorption	IEWI-016	%	0.5 maximum
6.5.	Environmental			
	UV-A 1000hr, 1.35 W/m ² irradiance, 8hr UV 60°C, 4hr condensation 50°C	IEWI-021	---	
	Visual inspection	---	---	No crazing or cracking.
	Mark Adherence	IEWI-012	---	Legible after 20 rubs. Minimum Print Contrast 3
	UV-B 1000hr, 0.49 W/m ² irradiance, 8hr UV 70°C, 4hr condensation 50°C	IEWI-021	---	
	Visual inspection	---	---	No crazing or cracking.
	Mark Adherence	IEWI-012	---	Legible after 20 rubs. Minimum Print Contrast 3
	6.6.	Flammability		
Resistance to Burning		ASTM D2761 Procedures B	---	Burn time shall not exceed one minute, and not more than 25% of indicator flag shall be burned or charred. No dripping or flowing. No burning of cotton.
Oxygen Index		IEWI-054	%	28 Minimum
Surface flame spread index, Is		ASTM E162	---	35 Maximum
Optical Smoke Density, Ds		ASTM E662	---	1.5 minutes 100 max 4 minutes 200 max.

TE CONNECTIVITY, SWINDON, UK

While TE Connectivity has made every reasonable effort to ensure the accuracy of the information in this specification, TE Connectivity does not guarantee that it is error-free, nor does TE Connectivity make any other representation, warranty or guarantee that the information is accurate, correct, reliable or current. TE Connectivity reserves the right to make any adjustments to the information contained herein at any time without notice. TE Connectivity expressly disclaims all implied warranties regarding the information contained herein, including, but not limited to, any implied warranties of merchantability or fitness for a particular purpose. The dimensions in this document are for reference purposes only and are subject to change without notice. Specifications are subject to change without notice. Consult TE Connectivity for the latest dimensions and design specifications.

If this document is printed it becomes uncontrolled.

	PROPERTY	TEST METHOD	UNITS	REQUIREMENTS
	Toxicity	BSS 7239	ppm, max	Carbon monoxide3500 Nitrogen oxides100 Sulphur dioxide100 Hydrogen chloride500 Hydrogen fluoride200 Hydrogen bromide100 Hydrogen cyanide150
	Effective Heat of Combustion ⁱ	ASTM E1354		
	Average Heat Release Rate, 3 minutes		KW/m ²	120 Maximum
	Average Extinction Area, 3 minutes		m ² /kg	140 Maximum
6.7.	Print Performance			
	Print Quality	TE Document 411-121002	---	Initial print contrast score C8 minimum
	Mark Adherence	IEWI-012	---	Legible after 50 rubs. Minimum Print Contrast 3
	Solvent Resistance	IEWI-014	---	Legible after 30 brush strokes. Minimum Print Contrast 3
	Fluid Resistance 24hr fluid immersion at 21° ± 3°C	IEWI-012	---	Legible after 20 wipes. Minimum Print Contrast 3
	Print Permanence IRM902 MIL-PRF-23699 Skydrol LD-4 MIL-H-83282 JP-8 Diesel Fuel Kilfrost DF Plus Tap Water 5% Sodium chloride solution 1% Teepol solution			

ⁱ This information is included for guidance only and is used by rail manufacturers when carrying out a product fire risk assessment. The typical requirements are the minimum recommended by The US National Association of State of Fire Marshals and maybe adopted by standard NPFA 130 during the next revision.

TE CONNECTIVITY, SWINDON, UK

While TE Connectivity has made every reasonable effort to ensure the accuracy of the information in this specification, TE Connectivity does not guarantee that it is error-free, nor does TE Connectivity make any other representation, warranty or guarantee that the information is accurate, correct, reliable or current. TE Connectivity reserves the right to make any adjustments to the information contained herein at any time without notice. TE Connectivity expressly disclaims all implied warranties regarding the information contained herein, including, but not limited to, any implied warranties of merchantability or fitness for a particular purpose. The dimensions in this document are for reference purposes only and are subject to change without notice. Specifications are subject to change without notice. Consult TE Connectivity for the latest dimensions and design specifications.

If this document is printed it becomes uncontrolled.

	PROPERTY	TEST METHOD	UNITS	REQUIREMENTS
	Isopropyl alcohol wipe	IEWI-012 Soaked "Super Twill" cloth	---	Legible after 20 wipes. Minimum Print Contrast 3
6.8.	Thermal			
	Heat Ageing, 168hr 135°C Tensile Strength Ultimate Elongation	IEWI-008 IEWI-002 IEWI-002	MPa (psi) %	5.25 (761) minimum 150 minimum
	Thermal Ageing, 240hr 120°C Mark Adherence	EN50343, IEWI-008 IEWI-012	---	Legible after 20 rubs, Minimum Print Contrast 3
	Tensile Strength Ultimate Elongation	IEWI-002 IEWI-002	MPa (psi) %	5.25 (761) minimum 150 minimum
7.0.	SPECIFIC TESTS FOR ZHD-SCE			
7.1.	Environmental			
	Fungus Resistance, ISO 846 Method B 56 days Mark Adherence	IEWI-012	---	Legible after 20 rubs, Minimum Print Contrast 3
	Tensile Strength Ultimate Elongation	IEWI-002 IEWI-002	MPa (psi) %	5.0 (725) minimum 150 minimum
7.2.	EN45545-2 Requirement set R22/R23 Hazard Level 2 Oxygen Content (OI)	BS EN ISO 4589-2	%	28 Maximum
	Smoke Density, Ds, Max	EN ISO 5659-2: 25 kW/m ²	---	300 Maximum
	Toxicity, CIT _{NLP}	NF X 70-100-1 and NF X 700-100-2	---	0.9 Maximum

TE CONNECTIVITY, SWINDON, UK

While TE Connectivity has made every reasonable effort to ensure the accuracy of the information in this specification, TE Connectivity does not guarantee that it is error-free, nor does TE Connectivity make any other representation, warranty or guarantee that the information is accurate, correct, reliable or current. TE Connectivity reserves the right to make any adjustments to the information contained herein at any time without notice. TE Connectivity expressly disclaims all implied warranties regarding the information contained herein, including, but not limited to, any implied warranties of merchantability or fitness for a particular purpose. The dimensions in this document are for reference purposes only and are subject to change without notice. Specifications are subject to change without notice. Consult TE Connectivity for the latest dimensions and design specifications.

If this document is printed it becomes uncontrolled.

	PROPERTY	TEST METHOD	UNITS	REQUIREMENTS
	BS6853 Interior minor use of materials of mass 100g to 500g, Vehicle category II			
	Oxygen Index (OI)	BS EN ISO 4589-2	%	28 Maximum
	Smoke (3m ³)	Annex D, Small scale test	---	0.061 Maximum
	Toxicity, Annex B	NF X 70-100	---	3.6 Maximum
7.3.	Print Performance			
	Fluid Resistance, Diesel, 168hr immersion at 70°C ± 3°C	IEWI-013 Test after 3hr 50min conditioning at 23°C		
	Mark Adherence (As supplied only)	IEWI-012	---	Legible after 10 rubs (eraser), Minimum Print Contrast 3
	Tensile Strength Ultimate Elongation	IEWI-002 IEWI-002	MPa (psi) %	4.9 (710) minimum 120 minimum
	Fluid Resistance, Liquid Fuel (IRM903), 168hr immersion at 70°C ± 2°C	EN50343, IEWI-029		
	Mark Adherence (As supplied only)	IEWI-012	---	Legible after 10 rubs (eraser), Minimum Print Contrast 3
	Fluid Resistance, Mineral Oil (IRM902), 70hr immersion at 50°C ± 2°C	EN50343, IEWI-029		
	Mark Adherence (As supplied only)	IEWI-012	---	Legible after 10 rubs (eraser), Minimum Print Contrast 3
	Tensile Strength Ultimate Elongation	IEWI-002 IEWI-002	MPa (psi) %	5.25 (761) minimum 150 minimum

TE CONNECTIVITY, SWINDON, UK

While TE Connectivity has made every reasonable effort to ensure the accuracy of the information in this specification, TE Connectivity does not guarantee that it is error-free, nor does TE Connectivity make any other representation, warranty or guarantee that the information is accurate, correct, reliable or current. TE Connectivity reserves the right to make any adjustments to the information contained herein at any time without notice. TE Connectivity expressly disclaims all implied warranties regarding the information contained herein, including, but not limited to, any implied warranties of merchantability or fitness for a particular purpose. The dimensions in this document are for reference purposes only and are subject to change without notice. Specifications are subject to change without notice. Consult TE Connectivity for the latest dimensions and design specifications.

If this document is printed it becomes uncontrolled.

	PROPERTY	TEST METHOD	UNITS	REQUIREMENTS
	Mark Adherence, Acid / Base Resistance, 1 minute immersion at 23°C, as supplied only	EN50343, IEWI-039		Legible after 10 rubs (eraser), Minimum Print Contrast 3
	1M HCl		---	
	1M NaOH		---	

8. STANDARD TEST FLUIDS

Fluid	Description
IRM902	Reference Oil
IRM903	Reference Oil
MIL-PRF-23699	Synthetic lubricating oil STD class (NATO Code 0-156). Has replaced MIL-L-7808 oil at temperatures above 25°C.
Skydrol LD-4	Widely used aviation phosphate ester hydraulic fluid.
MIL-H-83282	The principal hydraulic fluid used in military aircraft. It replaces MIL-H-5606.
MIL-T-83133 (JP-8)	Kerosene based jet fuel, replacement for JP-4. NATO code is F-34. It's specified by MIL-DTL-83133 and British Defence Standard 91-87.
Diesel Fuel (BS EN 590:2009+A1)	General automotive fuel
Kilfrost DF Plus (SAE-AMS-1424)	Anti-icing/De-icing Fluid
Tap Water	Universal solvent
5% Sodium chloride solution	Commonly used detergent
Detergent (1% Teepol)	Commonly used detergent
IPA - Isopropyl alcohol	Widely used as a solvent and cleaner
1M HCl (Acid)	Standard Hydrochloric acid solution (1mol)
1M NaOH (Base)	Standard Sodium Hydroxide solution (1mol)

TE (Logo) is a trademark.

ASTM is a trademark of the American Society for Testing and Materials. Other logos, product and Company names mentioned herein may be trademarks of their respective owners.

TE CONNECTIVITY, SWINDON, UK

While TE Connectivity has made every reasonable effort to ensure the accuracy of the information in this specification, TE Connectivity does not guarantee that it is error-free, nor does TE Connectivity make any other representation, warranty or guarantee that the information is accurate, correct, reliable or current. TE Connectivity reserves the right to make any adjustments to the information contained herein at any time without notice. TE Connectivity expressly disclaims all implied warranties regarding the information contained herein, including, but not limited to, any implied warranties of merchantability or fitness for a particular purpose. The dimensions in this document are for reference purposes only and are subject to change without notice. Specifications are subject to change without notice. Consult TE Connectivity for the latest dimensions and design specifications.

If this document is printed it becomes uncontrolled.