



Installation and Safety Instructions

22553

49782

98073

LED Recessed Downlight Kit



These instructions are for your safety. Please read through them thoroughly before use and retain for future reference.

Tools Required (not supplied)

3mm Flat Blade Screwdriver
6mm Cross Headed Screwdriver
Power Drill
64mm Hole Saw / Keyhole Saw
File and pencil

Sundries / Extras (not supplied)

Insulating Tape
Earth Sleeving

Kit contents and cable layout

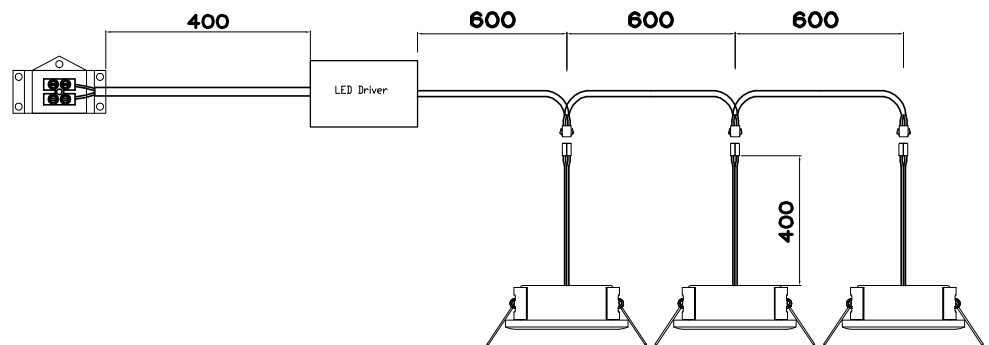

Before You Start

- Check the pack and make sure you have all of the parts shown above. If not, contact your local Trade counter who will be able to help you.
- Decide on an appropriate location for your product (see siting instructions below).
- An assistant may be required during fitting of this product.
- **If you are in any doubt about installing this product, consult a qualified electrician.**

Siting Instructions

- 1) This product is suitable for indoor use only.
- 2) Do **not** attach to surfaces which are damp or freshly painted.
- 3) The chosen location should allow for the product to be securely mounted and safely connected to the mains supply (lighting circuit).
- 4) Expert advice should be sought before installing downlighters in any ceiling forming a fire barrier e.g. ceilings between flats etc.
- 5) These products are IP20 rated and if fitting in a bathroom are **only** suitable for use in dry, outside zones of a bathroom. A 30mA RCD must be used in accordance with the current IEE wiring regulations.

Ceiling Preparation

Hole Diameter: 64mm Minimum Ceiling Depth: 140mm

- 1) Ensure a minimum depth of ceiling void of 140mm is available See Fig. 1 on page 3.
- 2) When more than one downlight is to be installed, the distance between units must be at least 0.3m (30cm). Keep LED drivers as far from the lamp heads as possible to avoid overheating.
- 3) Cut the 64mm mounting holes in the ceiling taking care not to foul any pipes, mains cables or joists beneath the surface.
- 4) All measurements are based on a ceiling with a 12mm thickness. If your ceiling thickness is less than 12mm, deduct approximately 5mm from the ceiling diameter shown above. If the ceiling is thicker than 12mm, gradually increase the hole until a snug fit is achieved. It is always recommended to cut the hole slightly smaller than the size specified, and then file the hole until the recessed unit fits snugly.
- 5) Ensure free movement of air around the fitting by removing any roof void insulation from at least 100mm around the hole. Under no circumstances must these fittings be covered with insulating matting or similar material.





These units are **Safety Extra Low Voltage** and must not be earthed. If there are any incoming earth cables, they must be joined together and well insulated with good quality insulation tape. This is to ensure earth continuity throughout your property.

UNDER NO CIRCUMSTANCES CONNECT THE MAINS (240V) DIRECTLY TO THESE FITTINGS. ONLY USE THE SUPPLIED LED DRIVER AND CABLE LOOM WITH THIS KIT.

Wiring

IMPORTANT. Always switch off the electricity supply at the mains during installation and maintenance. We recommend that the fuse is withdrawn or circuit breaker switched off at the distribution board whilst work is in progress (turning off the lightswitch is not sufficient). All fittings must be installed by a competent person in accordance with current IEE Wiring Regulations (BS7671) and local Building Regulations. If in doubt, consult a qualified electrician. These fittings are not suitable for use with dimmer switches.

- 1) Connect mains supply cable to the terminal block. (Use minimum 1.0 mm² core cable H03VV-F or equivalent). Terminate your Earth and Loop cables as necessary.
- 2) Open terminal block box by loosening screw. Loosen screws on cable clamp and fit mains supply wiring into cable clamp. (See Fig. 2 and Fig. 3)
- 3) Refit terminal block cover and tighten screw.
- 4) Check all connections are tight. Tighten cable clamp screw.

Installation

- 1) Always switch off or disconnect from the mains before installation.
- 2) Feed the supply cable and LED driver through the mounting hole. Squeeze the spring clips upwards towards the ceiling and fit the arms into the ceiling hole.
- 3) Ensure the LED driver is kept a MINIMUM of 300MM away from the lamp body to ensure the cables and transformer are not subjected to excess heat from the lamp unit.
- 4) Push the unit upward until firmly in position, ensuring that the cable is not trapped.
- 5) Replace the circuit fuse and switch on the mains to test.
- 6) LEDs are rated at 50,000 hrs. However, the LED unit is interchangeable should they fail prematurely.

Fig.1

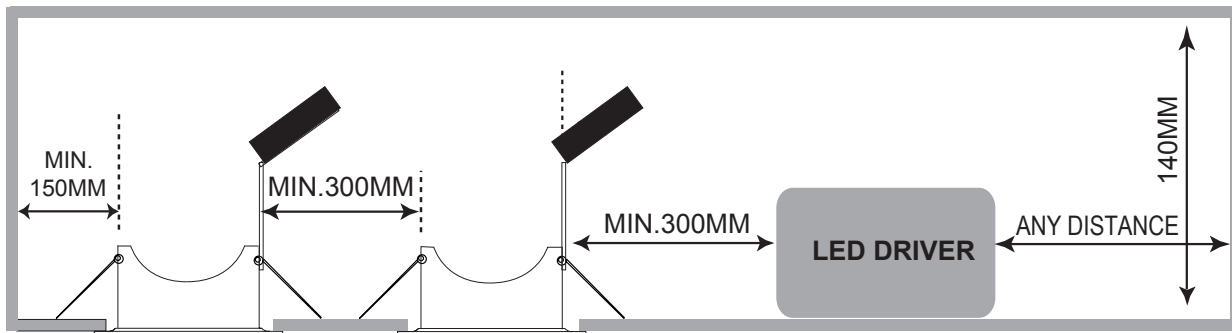

Fig. 2

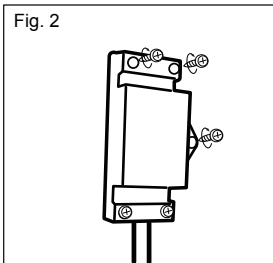
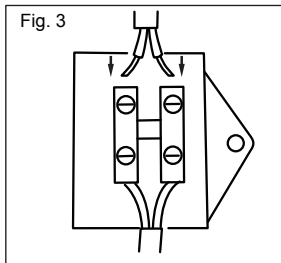

Fig. 3



Care & Use

- Always switch off or disconnect from the mains when cleaning the product.
- Wipe clean with a soft dry cloth. Never use scourers, abrasives or chemical cleaners. Do not allow moisture to come into contact with electric parts.



Waste electrical products should not be disposed of with normal household waste. Please recycle where facilities exist. Check with your Local Authority or retailer for recycling advice.