

**PLEASE CHECK WWW.MOLEX.COM FOR LATEST PART INFORMATION**

**Part Number:** **0190020025**  
**Status:** **Active**  
**Overview:** Standard Quick-Disconnect Terminals  
**Description:** Avikrimp™ Fully Insulated Quick Disconnect, Female, for 14-16 AWG Wire, Mylar Tape

**Documents:**

[Drawing \(PDF\)](#) [Product Specification PS-19902-015 \(PDF\)](#)  
[Product Specification PS-19902-011 \(PDF\)](#) [RoHS Certificate of Compliance \(PDF\)](#)  
[Product Specification PS-19902-014 \(PDF\)](#)

**Agency Certification**

CSA LR18689  
 UL E79133

**General**

Product Family Quick Disconnects  
 Series 19002  
 Crimp Quality Equipment Yes  
 Insulated Fully  
 Overview Standard Quick-Disconnect Terminals  
 Product Name Avikrimp™  
 Type Quick Disconnect  
 UPC 800753027312

**Physical**

Barrel Type Closed  
 Color - Resin Blue  
 Flammability 94V-2  
 Gender Female  
 Glow-Wire Compliant Yes  
 Insulation Nylon (PA)  
 Lock to Mating Part None  
 Material - Metal Brass  
 Material - Plating Mating Tin  
 Material - Plating Termination Tin  
 Net Weight 1.164/g  
 Orientation Straight  
 Packaging Type Adhesive Tape on Reel  
 Polarized to Mating Part No  
 Tab Thickness 0.81mm  
 Tab Width 6.35mm  
 Temperature Range - Operating -65°C to +105°C  
 Wire Insulation Diameter 3.94mm max.  
 Wire Size AWG 14, 16  
 Wire Size mm² 1.30-2.00

**Electrical**

Voltage - Maximum 300V

**Solder Process Data**

Lead-free Process Capability N/A

**Material Info**

Old Part Number BB-5263T

**Reference - Drawing Numbers**

Product Specification PS-19902-011, PS-19902-014, PS-19902-015  
 Sales Drawing SD-19002-004

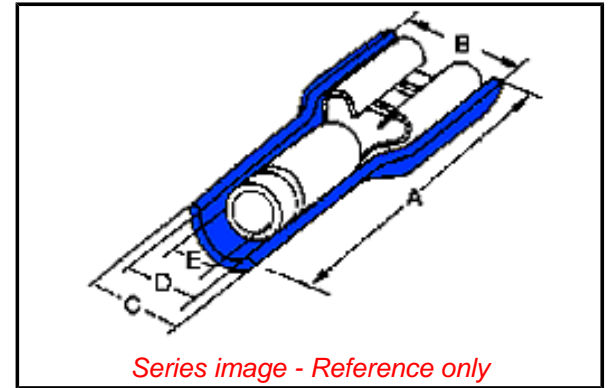

**EU ELV**

**Not Relevant**

**EU RoHS**

**Compliant**

**REACH SVHC**

Not Contained Per  
 -ED/79/2015 (17  
 December 2015)

**Halogen-Free**

**Status**

**Low-Halogen**

**Need more information on product environmental compliance?**

Email [productcompliance@molex.com](mailto:productcompliance@molex.com)  
 Please visit the [Contact Us](#) section for any non-product compliance questions.

China ROHS

ELV

Green Image

Not Relevant

**Search Parts in this Series**

19002 Series

**Use With**

19001-0006 , 19001-0007

**Application Tooling | FAQ**

*Tooling specifications and manuals are found by selecting the products below. Crimp Height Specifications are then contained in the Application Tooling Specification document.*

**Global**

**Description**

**Product #**

Mini-Mac™

0638850200

Applicator

ATP Crimp Dies

0192880130

for the Tape Crimp

Module and ATP-101

& 301 Press

This document was generated on 03/04/2016

**PLEASE CHECK [WWW.MOLEX.COM](http://WWW.MOLEX.COM) FOR LATEST PART INFORMATION**