

# Champ® LED Luminaires VMV Series LED Fixtures

## Installation & Maintenance Information

**Crouse-Hinds**  
by **EATON**

IF 1743

SAVE THESE INSTRUCTIONS FOR FUTURE REFERENCE

### APPLICATION

Champ® VMV Series Luminaires are suitable for use in the following hazardous (classified) areas as defined by the National Electrical Code (NEC®).

Refer to the luminaire nameplate for specific classification information, maximum ambient temperature suitability and corresponding operating temperature (T-code).

Luminaire construction is designed for use indoors and outdoors in marine and wet locations, where moisture, dirt, corrosion, vibration and rough usage may be present.

### VMV:

#### NEC/CEC

- Class I, Division 2, Groups A, B, C, D
- Class II, Groups E, F, G
- Class III
- Class I, Zone 2 nA nR
- Zone 21 tb
- Simultaneous Presence
- Wet Locations, Type 4X

#### UL Standards

- UL 844 Hazardous (Classified)
- UL1598 Luminaires, UL1598A Marine

#### CSA Standard

- CSA C22.2 No. 137

#### IEC/ATEX Standards

- IEC 60079-0:2011 / EN 60079-0:2012
- IEC 60079-15:2010 / EN 60079-15:2010
- IEC 60079-31:2008 / EN 60079-31:2009
- IEC 60529:2001 / EN 60529:2001
- IEC 60598-1:2008 / EN 60598-1:2008
- IEC 60598-2:2008 / EN 60598-2:2008

#### Fixture Markings

- IECEx UL 13.0052X
- DEMKO 13 ATEX 1305741X
- DEMKO 13 ATEX 1476031X
- See Table 1 for temperature codes

### Input voltage:

100-277 VAC 50/60 Hz  
100-250 VDC  
347-480 VAC 50/60 Hz

FIGURE 1

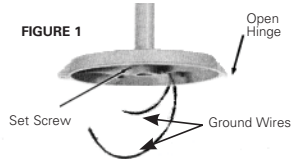

### WARNING

To avoid the risk of fire, explosion or electric shock, this product should be installed, inspected and maintained by a qualified electrician only, in accordance with all applicable electrical codes.

### WARNING

#### To avoid electric shock:

Be certain electrical power is OFF before and during installation and maintenance.

Luminaire must be supplied by a wiring system with an equipment grounding conductor.

#### To avoid burning hands:

Make sure lens and housing are cool when performing maintenance.

### INSTALLATION

#### MOUNTING:

1. Mount the cover module in its support position.
  - Ceiling and wall mount: mark and drill desired location on mounting surface. Secure with 1/4" (6mm) bolts or lag screws (not provided).
  - Pendant, cone, stanchion mount: securely thread onto the appropriate NPT size conduit. Tighten set screw located in the conduit hub. See Figure 1.
  - Eaton's Crouse-Hinds HTL thread lubricant must be added to the conduit threads to prevent water from entering the fixture.

#### Wiring

1. Pull field wiring into cover module.
2. Close all unused conduit entries with conduit plugs provided. To prevent galling and to ensure watertightness, lubricate conduit plugs with Eaton's Crouse-Hinds HTL lubricant before installing, and secure wrench-tight with at least five (5) full threads engaged (42-52 ft.-lb. for 3/4" plugs, and 58-68 ft.-lb. for 1" plugs).
3. Hang LED luminaire on the cover module hinge hook. See Figure 2a.

4. Connect supply wires to luminaire wire leads or terminal block per the attached wiring diagrams using methods that comply with all applicable codes. See Figure 2b. Tighten all electrical connections.
5. Close driver housing onto cover module, making sure that all wires are safely inside driver housing. Tighten captive closing screw to 30 in.-lbs. (3.4 N-m). Ensure two (2) bosses on driver housing are in contact with cover module.
6. Turn power on.



FIGURE 2a

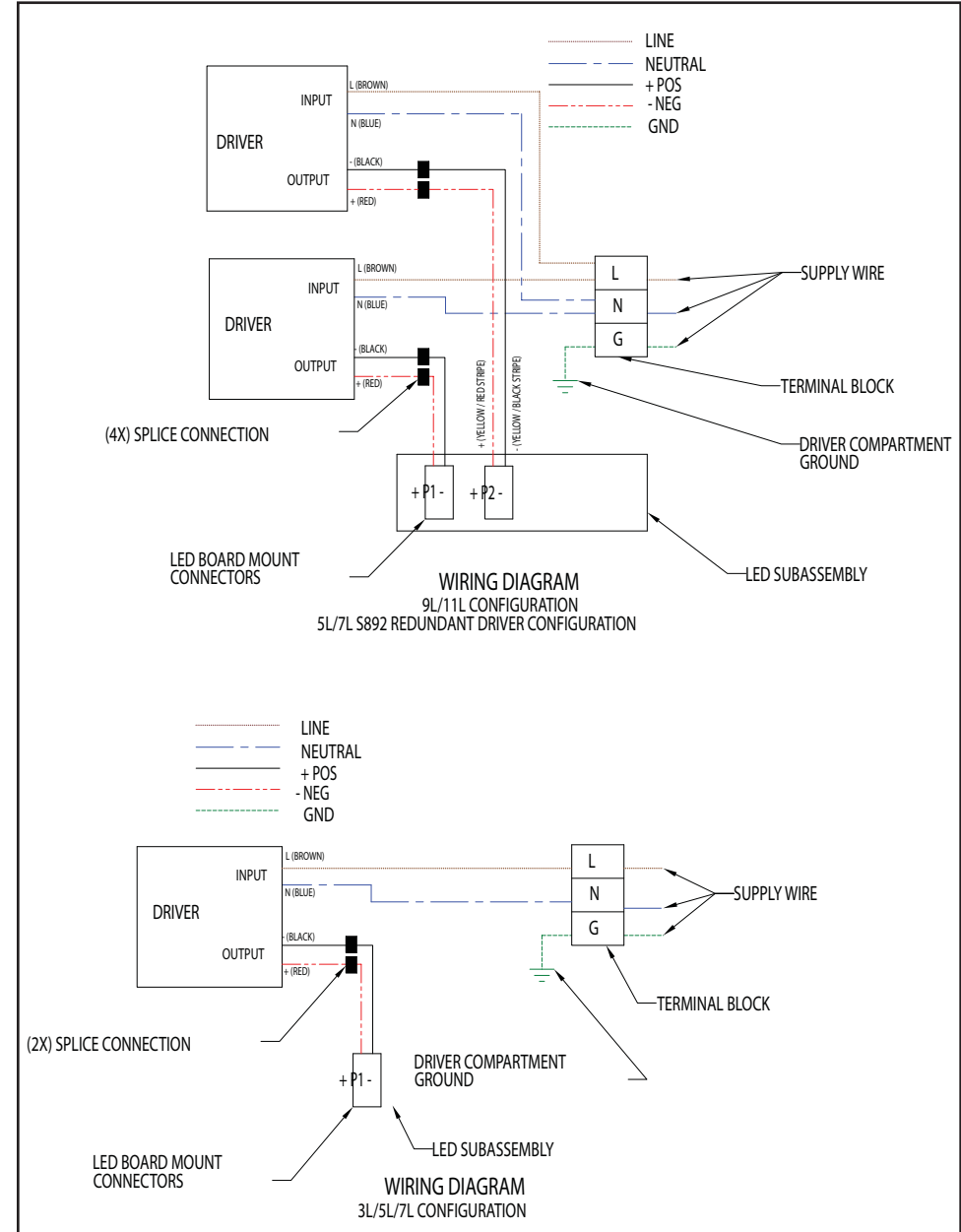

FIGURE 2b

## WIRE GUARD INSTALLATION

Loosen but DO NOT completely remove wire guard screw. If already loosened, move to next step.

Set wire guard in place by pushing it over the bottom rim of the fixture which is on the lowest casting until it sits in place above that rim. Ensure that the wire guard is in place around the complete bottom and is not partially in place above the rim.

Tighten the screw attached to wire guard until guard is securely attached to bottom casting. The screw will be tight enough when the wire guard can no longer easily rotate on the fixture.

**NOTE:** The sheet metal tabs which the screw goes through do not need to be touching for the guard to be securely fastened; the wire guard will be secure without those two tabs touching one another.

## FIELD ASSEMBLED FIXTURES

### Champ® VMV Series Lighting Fixtures, 50-140 Watt

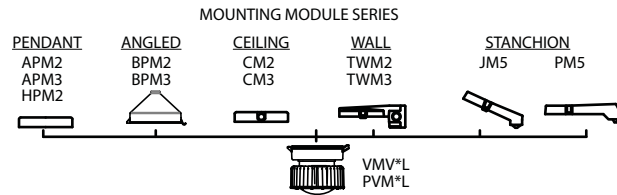



### MOUNTING MODULE NOTES:

- 2: indicates 3/4" NPT thread
- 3: indicates 1" NPT thread
- 5: indicates 1-1/2" thread
- Pendant, angled, ceiling and stanchion mounts have one (1) conduit entry; ceiling and wall mounts have five (5) conduit entries

## MAINTENANCE

1. Perform visual, electrical and mechanical inspections on a regular basis. The environment and frequency of use should determine this. However, it is recommended that checks be made at least once a year. We recommend an Electrical Preventive Maintenance Program as described in the National Fire Protection Association Bulletin NFPA No. 70B: Recommended Practice For Electrical Equipment Maintenance ([www.nfpa.org](http://www.nfpa.org)).
2. The lens should be cleaned periodically to ensure continued lighting performance. To clean, wipe the lens with a clean, damp cloth. If this is not sufficient, use a mild soap or a liquid cleaner such as Collinite NCF or Duco #7. Do not use an abrasive, strong alkaline or acid cleaner. Damage may result. Visually check for undue heating evidenced by discoloration of wires or other components, damaged parts or leakage evidenced by water or corrosion in the interior. Replace all worn, damaged or malfunctioning components, and clean gasket seals before putting the luminaire back into service.

## CHAMP LED SAFETY CABLE (NEC/CEC ONLY)

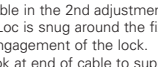
1. Pass cable through the Kwik-Loc adjustment in hole in the direction of the arrows. 
2. Loop the cable around the fixture body (between the fins and driver housing) and back through the Kwik-Loc 2nd adjustment pin hole in the direction of the arrows. 
3. Pull the cable in the 2nd adjustment pin hole, ensuring the cable and Kwik-Loc is snug around the fixture. 
4. Confirm engagement of the lock.
5. Attach hook at end of cable to support structure (anchor).

4. Electrically check to make sure that all connections are clean and tight.
5. Mechanically check that all parts are properly assembled.
6. If the lens is removed from the fixture, the lens gasket must be replaced to maintain restricted breathing ratings.

## REPLACEMENT PARTS

Eaton's Crouse-Hinds VMV and NVMV Series Champ luminaires are designed to provide years of reliable lighting performance. However, should the need for replacement parts arise, they are available through your authorized Eaton's Crouse-Hinds distributor. Assistance may also be obtained through your local Eaton's Crouse-Hinds representative.

Eaton's Crouse-Hinds Sales Service Department, 1201 Wolf Street, Syracuse, New York 13208, Phone (866) 764-5454.

## WARNING

### To avoid electric shock:

Be certain electrical power is OFF before and during installation and maintenance. Luminaire must be supplied by a wiring system with an equipment grounding conductor.

### To avoid burning hands:

Make sure globe or refractor and lamp are cool when performing maintenance.

## INSTALLATION CHECKLIST

1. Verify sufficient HTL lubricant is on conduit plugs (recommend approximately 1/8" bead around the first thread of plug) and that all unused conduit entries on the cover module are closed with lubricated plugs. 

2. Verify conduit plugs are installed to at least five (5) full threads into the cover module conduit entries. 

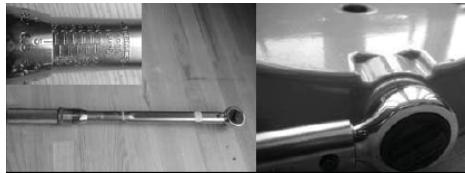
3. Verify installed conduit plugs are torqued to 42-52 ft.-lbs. for 3/4" plugs and 58-68 ft.-lbs. for 1" plug. 

4. Verify supply wires are connected to luminaire wire leads (or terminal block) per wiring diagrams. 

5. Verify all electrical connections are tightened. 

6. Verify all wires are safely and neatly inside driver housing and not on top of wire terminal. Close driver housing onto cover module. 

7. Verify captive closing screw is tightened to 30 in.-lbs. (3.4 N-m) and two (2) bosses on driver housing are in contact with cover module. 

Driver Option	Ambient	Supply Wire	Class II, Div. 1	Simultaneous Rating	Class I, Div 2	Class I, Zone 2	Zone 21 AEx tb IIIC; Class III, Div 1; Class II, Div1, Groups E, F, and G
UNV1	40°C	75°C	T5	T3C	T5	T6	T66°C
UNV1	55°C	90°C	T4A	T3B	T5	T5	T83°C
UNV1	65°C	90°C	T4A	T3B	T4A	T5	T92°C
UNV34	40°C	75°C	T5	T3C	T3C	T4	T70°C
UNV34	55°C	90°C	T4A	T3A	T3A	T4	T85°C
RL, GL, BL, AL	40°C	75°C	T6	T4A	T5	T5	T60°C
RL, GL, BL, AL	55°C	90°C	T6	T4A	T4A	T4	T75°C

Table 1