

PLEASE CHECK WWW.MOLEX.COM FOR LATEST PART INFORMATION

Part Number: **0196001306**
Status: **Active**
Overview: Standard Quick-Disconnect Terminals
Description: Avikrimp™ Fully Insulated Female Quick Disconnect

Documents:

[3D Model](#) [Product Specification PS-19902-015 \(PDF\)](#)
[Drawing \(PDF\)](#) [RoHS Certificate of Compliance \(PDF\)](#)
[Product Specification PS-19902-014 \(PDF\)](#)

Agency Certification

CSA LR18689
 UL E79133

General

Product Family Quick Disconnects
 Series 19600
 Crimp Quality Equipment Yes
 Insulated Fully
 Overview Standard Quick-Disconnect Terminals
 Product Name Avikrimp™
 Type Quick Disconnect
 UPC 800753117808

Physical

Barrel Type Closed
 Color - Resin Yellow
 Flammability 94V-2
 Gender Female
 Glow-Wire Compliant No
 Insulation Nylon (PA)
 Lock to Mating Part None
 Material - Metal Brass
 Material - Plating Mating Tin
 Material - Plating Termination Tin
 Net Weight 1.366/g
 Orientation Straight
 Packaging Type Adhesive Tape on Reel
 Polarized to Mating Part No
 Tab Thickness 0.81mm
 Tab Width 6.35mm
 Temperature Range - Operating -65°C to +105°C
 Wire Insulation Diameter 6.89x4.32mm max.
 Wire Size AWG 16+16, 18+18, 20+20, 22+22

Electrical

Voltage - Maximum 300V

Solder Process Data

Lead-free Process Capability N/A

Material Info

Old Part Number P-5242T

Reference - Drawing Numbers

Product Specification PS-19902-014, PS-19902-015
 Sales Drawing SD-19600-1300

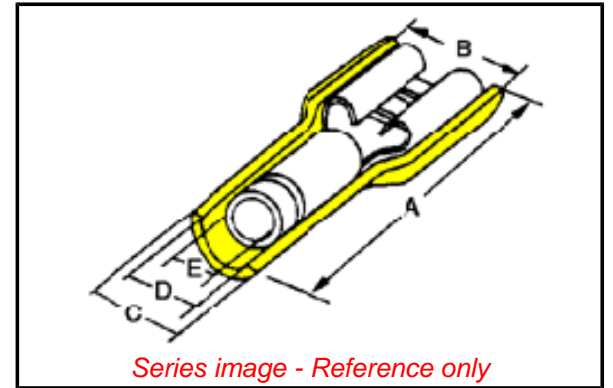

Series image - Reference only

EU ELV

Not Relevant

EU RoHS

Compliant

REACH SVHC

Not Contained Per -
 ED/108/2014 (17 Dec
 2014)

Halogen-Free

Status

Low-Halogen

**Need more information on product
 environmental compliance?**

Email productcompliance@molex.com
 Please visit the [Contact Us](#) section for any
 non-product compliance questions.

China ROHS

ELV

Green Image

Not Relevant

Search Parts in this Series

19600 Series

Application Tooling | FAQ

*Tooling specifications and manuals are
 found by selecting the products below.
 Crimp Height Specifications are then
 contained in the Application Tooling
 Specification document.*

Global

Description	Product #
ATP Crimp Dies for the Tape Crimp Module and ATP-101 & 301 Press	<u>0190270310</u>
ATP Crimp Dies for the Tape Crimp Module and ATP-101 & 301 Press	<u>0190270001</u>

This document was generated on 03/04/2016

PLEASE CHECK WWW.MOLEX.COM FOR LATEST PART INFORMATION