

PowerXL DC1, DA1 Series Adjustable Frequency AC Drives

2



Product Description

Eaton's PowerXL™ DC1 and DA1 variable frequency drives are the next generation of drives specifically engineered for today's machinery applications.

The DC1 is compact with only 14 basic parameters, SmartWire-DT connectivity, and outstanding ease of mounting and installation. The DC1 is perfect for quick commissioning and is ideal for panel builders. This drive supports single-phase motor applications, and detachable terminal blocks make control wiring much easier.

DA1 is the perfect match for demanding OEM applications. High-performance processor, safe torque off, multiple fieldbus protocols including SmartWire-DT, sensorless vector control and the possibility to operate permanent magnet motors are sure to leave a lasting impression.

Models rated at 480 volts, three-phase, 50/60 Hz are available in sizes ranging from 1 to 15 hp. Models rated at 240 volts, single- or three-phase, 50/60 Hz are available in sizes ranging from 0.5 to 7.5 hp. Models rated at 115 volts, single-phase, 50/60 Hz are available in the 0.5 to 3 hp size range.

Contents

Description

	<i>Page</i>
PowerXL DC1, DA1 Series Adjustable Frequency AC Drives	
Catalog Number Selection	V6-T2-9
Product Selection	V6-T2-10
Accessories	V6-T2-13
Technical Data and Specifications	V6-T2-14
Dimensions	V6-T2-18

Features

- Compact, space-saving design
- Rugged and reliable—200% for 4s (DA1) or 175% for 2s (DC1), 50 C rated
- DIN rail and screw mountable (FS1 and FS2)
- Side-by-side installation
- Industry-leading efficiency delivers energy savings to the customer
- Integrated EMC filters make the unit suitable for commercial and industrial networks
- Brake chopper as standard in frames 2 and higher
- Temperature-controlled fan
- RS-485/Modbus® and CANopen™ as standard
- PI (DC1), PID (DA1) controller as standard
- Several fieldbus options (DA1)
- SmartWire capability
- Removable I/O terminal blocks
- Contactor style power wiring
- Compatibility with single-phase motors (DC1)
- 200% torque at zero speed (DA1)
- Ability to run permanent magnet motors (DA1)
- PLC programming (DA1)
- Closed loop (DA1)
- Conformal coated boards (DA1)

Standards and Certifications

Product

- Complies with EN61800-3 (2004)

EMC (At Default Settings)

- EMC Category C1, C2 and C3 at default settings (1m, 5m, 25m)

Note

① See unit nameplate for more detailed approvals.

Safety ①

- 61800-5-1
- EN 60529
- CE
- UL
- cUL
- UkrSepro
- c-Tick
- RoHS compliant



Catalog Number Selection

DC1 Series Adjustable Frequency AC Drives

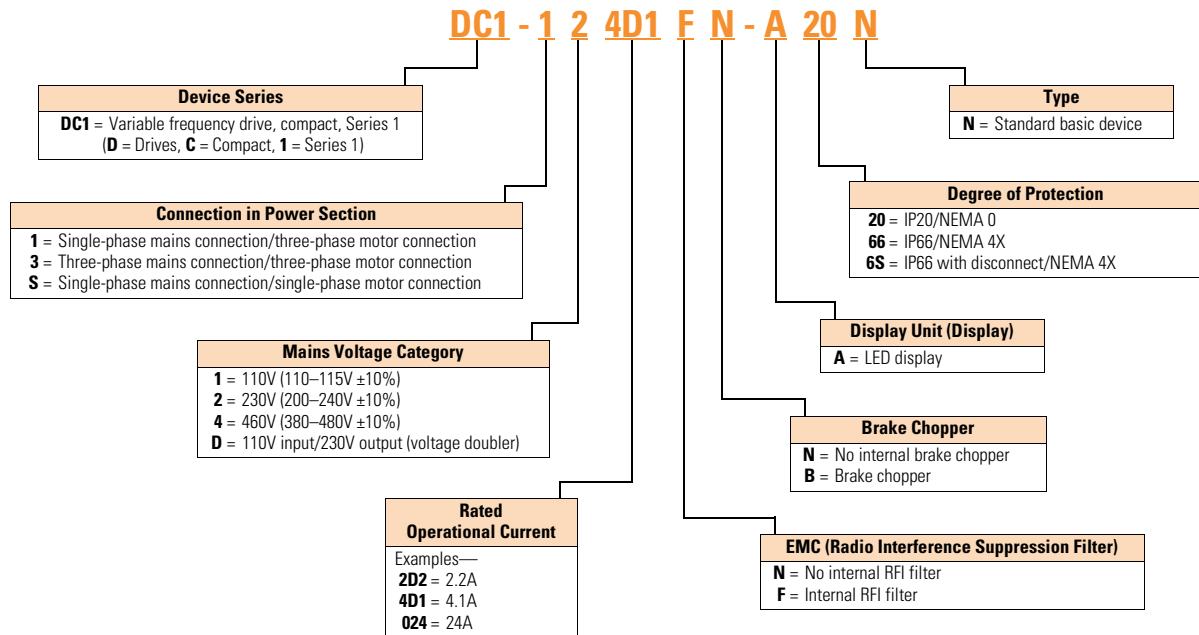

DA1 Series Adjustable Frequency AC Drives

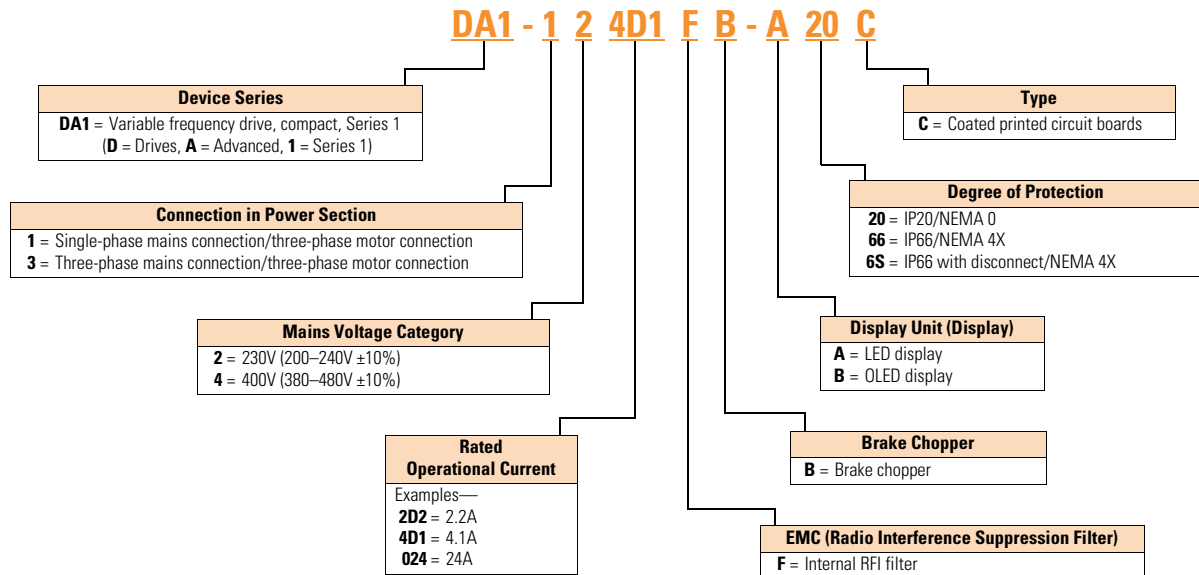

2.2

Adjustable Frequency Drives

PowerXL DC1, DA1 Series Adjustable Frequency AC Drives

Product Selection

DC1 Series ^①

2

IP20



hp ^②	kW	Volts	100% Continuous Current In (A)	Frame Size ^③	Catalog Number
0.5	0.37	115V single-phase in/ 115V single-phase out	7	1	DC1-S17D0NN-A20N
0.75	0.55		10.5	2	DC1-S1011NB-A20N
0.5	0.37	200–240V single-phase in/ 200–240V single-phase out	4.3	1	DC1-S24D3NN-A20N ^④
1	0.75		7	1	DC1-S27D0NN-A20N ^④
1.5	1.1		10	2	DC1-S2011NB-A20N ^④
0.5	0.37	115V single-phase in/ 230V three-phase out	2.3	1	DC1-1D2D3NN-A20N ^④
1	0.75		4.3	1	DC1-1D4D3NN-A20N
1.5	1.1		5.8	2	DC1-1D5D8NB-A20N
0.5	0.37	200–240V single-phase in/ 230V three-phase out	2.3	1	DC1-122D3NN-A20N ^④
1	0.75		4.3	1	DC1-124D3NN-A20N ^④
2	1.5		7	1	DC1-127D0NN-A20N ^④
2	1.5		7	2	DC1-127D0NB-A20N ^④
3	2.2		10.5	2	DC1-12011NB-A20N ^④
5	4		15	3	DC1-12015NB-A20N
0.5	0.37	200–240V three-phase in/ 230V three-phase out	2.3	1	DC1-322D3NN-A20N
1	0.75		4.3	1	DC1-324D3NN-A20N
2	1.5		7	1	DC1-327D0NN-A20N
2	1.5		7	2	DC1-327D0NB-A20N ^④
3	2.2		10.5	2	DC1-32011NB-A20N ^④
5	4		18	3	DC1-32018NB-A20N ^④
1	0.75	380–480V three-phase in/ 460V three-phase out	2.2	1	DC1-342D2NN-A20N ^④
2	1.5		4.1	1	DC1-344D1NN-A20N ^④
2	1.5		4.1	2	DC1-344D1NB-A20N ^④
3	2.2		5.8	2	DC1-345D8NB-A20N ^④
5	4		9.5	2	DC1-349D5NB-A20N ^④
7.5	5.5		14	3	DC1-34014NB-A20N ^④
10	7.5		18	3	DC1-34018NB-A20N ^④
15	11		24	3	DC1-34024NB-A20N ^④

Notes

- ① These are constant torque/high overload rated drives.
- ② For all applications, select the unit such that the motor current is less than or equal to the rated continuous output current.
- ③ Brake chopper circuit available as standard in frames 2 and 3.
- ④ RFI version available. Substitute with DC1-*****F*.* for this option.

IP66



IP66

hp ^①	kW	Volts	100% Continuous Current In (A)	Frame Size ^②	Catalog Number
0.5	0.37	115V single-phase in/ 115V single-phase out	7	1	DC1-S17D0NN-A6SN ^③
0.75	0.55		10.5	2	DC1-S1011NB-A6SN ^③
0.5	0.37	200–240V single-phase in/ 200–240V single-phase out	4.3	1	DC1-S24D3NN-A6SN ^{③④}
1	0.75		7	1	DC1-S27D0NN-A6SN ^{③④}
1.5	1.1		10	2	DC1-S2011NB-A6SN ^{③④}
0.5	0.37	115V single-phase in/ 230V three-phase out	2.3	1	DC1-1D2D3NN-A6SN ^③
1	0.75		4.3	1	DC1-1D4D3NN-A6SN ^③
1.5	1.1		5.8	2	DC1-1D5D8NB-A6SN ^③
0.5	0.37	200–240V single-phase in/ 230V three-phase out	2.3	1	DC1-122D3NN-A6SN ^{③④}
1	0.75		4.3	1	DC1-124D3NN-A6SN ^{③④}
2	1.5		7	1	DC1-127D0NN-A6SN ^{③④}
2	1.5		7	2	DC1-127D0NB-A6SN ^{③④}
3	2.2		10.5	2	DC1-12011NB-A6SN ^{③④}
5	4		15	3	DC1-12015NB-A6SN ^③
0.5	0.37	200–240V three-phase in/ 230V three-phase out	2.3	1	DC1-322D3NN-A6SN ^③
1	0.75		4.3	1	DC1-324D3NN-A6SN ^③
2	1.5		7	1	DC1-327D0NN-A6SN ^③
2	1.5		7	2	DC1-327D0NB-A6SN ^{③④}
3	2.2		10.5	2	DC1-32011NB-A6SN ^{③④}
5	4		18	3	DC1-32018NB-A6SN ^{③④}
1	0.75	380–480V three-phase in/ 460V three-phase out	2.2	1	DC1-342D2NN-A6SN ^{③④}
2	1.5		4.1	1	DC1-344D1NN-A6SN ^{③④}
2	1.5		4.1	2	DC1-344D1NB-A6SN ^{③④}
3	2.2		5.8	2	DC1-345D8NB-A6SN ^{③④}
5	4		9.5	2	DC1-349D5NB-A6SN ^{③④}
7.5	5.5		14	3	DC1-34014NB-A6SN ^{③④}
10	7.5		18	3	DC1-34018NB-A6SN ^{③④}

Notes

- ① For all applications, select the unit such that the motor current is less than or equal to the rated continuous output current.
 ② Brake chopper circuit available as standard in frames 2 and 3.
 ③ Non-disconnect version available. Substitute with **-A66N**.
 ④ RFI version available. Substitute with DC1-*******F***-**** for this option.

2.2

Adjustable Frequency Drives

PowerXL DC1, DA1 Series Adjustable Frequency AC Drives

DA1 Series ①

2

IP20



IP20

hp ②	kW	Volts	100% Continuous Current In (A)	Frame Size ③	Catalog Number
1	0.75	200–240V single-phase in/ 230V three-phase out	4.3	2	DA1-124D3FB-A20C
2	1.5		7	2	DA1-127D0FB-A20C
3	2.2		10.5	2	DA1-12011FB-A20C
1	0.75	200–240V three-phase in/ 230V three-phase out	4.3	2	DA1-324D3FB-A20C
2	1.5		7	2	DA1-327D0FB-A20C
3	2.2		10.5	2	DA1-32011FB-A20C
5	4		18	3	DA1-32018FB-A20C
7.5	5.5		24	3	DA1-32024FB-A20C
1	0.75	380–480V three-phase in/ 460V three-phase out	2.2	2	DA1-342D2FB-A20C
2	1.5		4.1	2	DA1-344D1FB-A20C
3	2.2		5.8	2	DA1-345D8FB-A20C
5	4		9.5	2	DA1-349D5FB-A20C
7.5	5.5		14	3	DA1-34014FB-A20C
10	7.5		18	3	DA1-34018FB-A20C
15	11		24	3	DA1-34024FB-A20C

IP66



IP66

hp ②	kW	Volts	100% Continuous Current In (A)	Frame Size ③	Catalog Number
1	0.75	200–240V single-phase in/ 230V three-phase out	4.3	2	DA1-124D3FB-A6SC ④
2	1.5		7	2	DA1-127D0FB-A6SC ④
3	2.2		10.5	2	DA1-12011FB-A6SC ④
1	0.75	200–240V three-phase in/ 230V three-phase out	4.3	2	DA1-324D3FB-A6SC ④
2	1.5		7	2	DA1-327D0FB-A6SC ④
3	2.2		10.5	2	DA1-32011FB-A6SC ④
5	4		18	3	DA1-32018FB-A6SC ④
1	0.75	380–480V three-phase in/ 460V three-phase out	2.2	2	DA1-342D2FB-A6SC ④
3	1.5		4.1	2	DA1-344D1FB-A6SC ④
5	2.2		5.8	2	DA1-345D8FB-A6SC ④
7.5	4		9.5	2	DA1-349D5FB-A6SC ④
10	5.5		14	3	DA1-34014FB-A6SC ④
15	7.5		18	3	DA1-34018FB-A6SC ④

IP66S



Notes

- ① These are constant torque/high overload rated drives.
- ② For all applications, select the unit such that the motor current is less than or equal to the rated continuous output current.
- ③ Brake chopper circuit available as standard in frames 2 and 3.
- ④ Non-disconnect version available. Substitute with **-A66C**.

Accessories

DC1 and DA1 Series

PC Communication Kit and Copy/Paste Module

Description	Catalog Number
BT communication stick	DX-COM-STICK
USB PC connection kit	DX-COM-PCKIT

Optional Communication Modules ^①

Description	Catalog Number
DeviceNet plug-in interface module	DX-NET-DEVICENET
PROFIBUS-DP plug-in interface module	DX-NET-PROFIBUS
EtherNet/IP plug-in interface module	DX-NET-ETHERNET-2
EtherCAT plug-in interface module	DX-NET-ETHERCAT-2
PROFINET plug-in interface module	DX-NET-PROFINET-2
Modbus TCP plug-in interface module	DX-NET-MOVBUSTCP-2
BACnet plug-in interface module	DX-NET-BACNETIP-2

Encoder Feedback Plug-In Option Module and Miscellaneous Cards

Description	Catalog Number
Local control/test option card	DXC-EXT-LOCSIM
HVACO drive running and tripped relay output card	DXC-EXT-2R01AO
Cascade control plug-in option module ^①	DXA-EXT-3R0
Dual relay output card	DXC-EXT-2R0
110V logic input card	DXC-EXT-IO110
230V logic input card	DXC-EXT-IO230
Encoder feedback plug-in option module ^①	DXA-EXT-ENCOD

Remote Keypad

Description	Catalog Number
LED remote keypad	DX-KEY-LED
OLED remote keypad	DX-KEY-OLED

Extension Cables and Data Cable Splitter

Description	Catalog Number
RJ45 communication cable w/terminating resistor	DX-CBL-TERM
RS-485 data cable, RJ45, 0.5m	DX-CBL-RJ45-0M5
RS-485 data cable, RJ45, 1.0m	DX-CBL-RJ45-1M0
RS-485 data cable, RJ45, 3.0m	DX-CBL-RJ45-3M0
RS-485 three-way data cable splitter, RJ45	DX-SPL-RJ45-3SL
RS-485 data cable splitter, RJ45, (1 connector to 2 socket)	DX-SPL-RJ45-2SL1PL

SmartWire Modules

Description	Catalog Number
SmartWire-DT interface for DC1 IP20	DX-NET-SWD3
SmartWire-DT interface for DA1 IP20	DX-NET-SWD1

Note

^① Only applicable for DA1.

Technical Data and Specifications

DC1 Series

2

Ratings

PowerXL DC1 Basic Controller IP20 Standard Ratings

Description	Specification
Protections	
Overload protection	150% for 60s for every 600 seconds
Overvoltage protection	Yes
Undervoltage protection	Yes
Ground fault protection	Yes
Overtemperature protection	Yes
Motor overload protection	Yes
Motor stall protection	Yes

Programmable Parameters

Description
Built-in Help card
14 Standard operation parameters
Reference scaling
Programmable start and stop functions
DC-brake at start and stop
Programmable V/Hz curve
Adjustable switching frequency
Autorestart function after fault
Protections and supervisions
Power section fault indication
External fault
Fieldbus communication
Second deceleration time
Analog input range selection, signal scaling and filtering
PI controller
Skip frequencies

Specifications

PowerXL DC1 Series Drives

Description	Specification
Input Ratings	
Input voltage (V_{in})	$\pm 10\%$
Input frequency (f_{in})	50/60 Hz (variation up to 48–62 Hz)
Connection to power	Maximum of one time every 30 seconds
Output Ratings	
Output voltage	0 to V_{in} ①
Continuous output current	Continuous rated current I_N at ambient temperature max. 122°F (50°C), 150% for 60 seconds, 175% for 2 seconds
Output frequency	0 to 500 Hz
Frequency resolution	0.1 Hz
Initial output current (I_{H})	175% for 2s for every 20 seconds Torque depends on motor
Control Characteristics	
Operation mode	U/f control, slip compensation
Switching frequency	4 to 32 kHz
Voltage reference	10 Vdc (max. 10 mA)
Field weakening point	0 to 500 Hz
Acceleration time	0.1 to 600 seconds
Deceleration time	0.1 to 600 seconds
Brake Resistor (Minimum Values) ②	
230V Series	FS2 and FS3 47 ohms
400V Series	FS2 100 ohms, FS3 47 ohms
Ambient Conditions	
Ambient operating temperature	+14°F (–10°C), no frost to +122°F (+50°C); Rated loadability I_N IP20—NEMA 0
Storage temperature	–40°F (–40°C) to +140°F (+60°C)
Relative humidity	0 to 95% RH, noncondensing, non-corrosive, no dripping water
Enclosure class	IP20 (FS1–FS3)

Notes

- ① Exception: 115V single-phase in, 230V three-phase out.
 ② Only FS2 and FS3 drives are equipped with brake chopper circuit.

Standards—DC1 Series**I/O Specifications**

- Digital inputs DI1–DI4 are programmable
- Digital, relay and analog outputs are programmable

Includes:

- Four inputs (two digital and two digital/analog)
- Analog inputs
 - 4–20 mA
 - 0–10V
- One output (analog or digital)
- One relay output
- RS-485 interface

Reliability

- Pretested components
- Computerized testing
- Final test with full load
- Conformal-coated boards
- Eaton's Electrical Services & Systems: national network of AF drive specialists

DC1 Series I/O Interface

Terminal	Signal	Factory Preset	Description
1	+24 Vdc	Control voltage for DI1–DI4	— Maximum load 100 mA Reference potential V
2	DI1	Digital Input 1	Start Enable FWD 8 to +30V (High, $R_1 > 6 \text{ k}\Omega$)
3	DI2	Digital Input 2	Start Enable REV 8 to +30V (High, $R_1 > 6 \text{ k}\Omega$)
4	DI3	Digital Input 3	Fixed frequency FF1 Digital: 8–30V (high)
	AI2	Analog Input 2	Fixed frequency FF1 Analog: 0 to +10V ($R_1 > 72 \text{ k}\Omega$) 0/4–20 mA ($R_8 = 500 \Omega$) Can be switched with parameter P16
5	+10 Vdc	Reference voltage, Output (+10V)	— Maximum load 10 mA Reference potential 0V
6	AI1	Analog Input 1	Frequency reference value ① (fixed frequency) Analog: 0 to +10V ($R_1 > 72 \text{ k}\Omega$) 0/4–20 mA ($R_8 = 500 \Omega$) Can be switched with parameter P16
	DI4	Digital Input 5	Frequency reference value ① (fixed frequency) Digital: 8–30V (high)
7	0V	Reference potential	— 0V = connection terminal 9
8	A01	Analog Output 1	Output frequency Analog: 0 to +10V, maximum 4–20 mA Can be switched with parameter P-25
	D01	Digital Output 1	Output frequency Digital: 8 to +24V
9	0V	Reference potential	— 0V connection terminal 7
10	K13	Relay 1, normally open contact	Active = RUN Maximum switching load: 250 Vac/6A or 30 Vdc/5A
11	K14	Relay 1, normally open contact	Active = RUN Maximum switching load: 250 Vac/6A or 30 Vdc/5A

Note

① Programmable function.

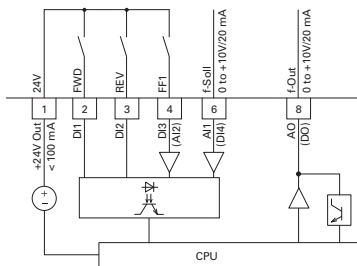

DA1 Series

2

Ratings

PowerXL DA1 Basic Controller IP20 Standard Ratings

Description	Specification
Protections	
Overload protection	150% for 60s for every 600 seconds
Overvoltage protection	Yes
Undervoltage protection	Yes
Ground fault protection	Yes
Overtemperature protection	Yes
Motor overload protection	Yes
Motor stall protection	Yes

Programmable Parameters

Description
Built-in Help card
14 Standard operation parameters
Reference scaling
Programmable start and stop functions
DC-brake at start and stop
Programmable V/Hz curve
Adjustable switching frequency
Autorestart function after fault
Protections and supervisions
Power section fault indication
External fault
Fieldbus communication
Safe torque off (STO) function
Analog input range selection, signal scaling and filtering
PI controller
Skip frequencies

Specifications

PowerXL DA1 Series Drives

Description	Specification
Input Ratings	
Input voltage (V_{in})	$\pm 10\%$
Input frequency (f_{in})	50/60 Hz (variation up to 48–62 Hz)
Connection to power	Maximum of one time every 30 seconds
Output Ratings	
Output voltage	0 to V_{in} ①
Continuous output current	Continuous rated current I_N at ambient temperature max. 122°F (50°C), 150% for 60 seconds, 200% for 4 seconds
Output frequency	0 to 500 Hz
Frequency resolution	0.1 Hz
Initial output current (I_{H1})	200% for 4s for every 40 seconds Torque depends on motor
Control Characteristics	
Operation mode	U/f control, slip compensation, sensorless vector control (SLV), vector control with feedback (CLV)
Switching frequency	4 to 32 kHz
Voltage reference	10 Vdc (max. 10 mA)
Field weakening point	0 to 500 Hz
Acceleration time	0.1 to 600 seconds
Deceleration time	0.1 to 600 seconds
Brake Resistor (Minimum Values) ②	
230V Series	FS2 and FS3 15 ohms
400V Series	FS2 33 ohms, FS3 22 ohms
Ambient Conditions	
Ambient operating temperature	+14°F (–10°C), no frost to +122°F (+50°C): Rated loadability I_N IP20—NEMA 0
Storage temperature	–40°F (–40°C) to +140°F (+60°C)
Relative humidity	0 to 95% RH, noncondensing, non-corrosive, no dripping water
Enclosure class	IP20 (FS1–FS3)

Notes

- ① Exception: 115V single-phase in, 230V three-phase out.
 ② Only FS2 and FS3 drives are equipped with brake chopper circuit.

Standards—DA1 Series

I/O Specifications

- Digital inputs D11–D15 are programmable
- Digital, relay and analog outputs are programmable

Includes:

- Five inputs (three digital and two digital/analog)
- Analog inputs
 - 4–20 mA
 - 0–10V
- Two outputs (analog or digital)
- Two relay outputs
- RS-485 interface

Reliability

- Pretested components
- Computerized testing
- Final test with full load
- Conformal-coated boards
- Eaton's Electrical Services & Systems: national network of AF drive specialists

DA1 Series I/O Interface

Terminal	Signal	Factory Preset	Description
1	+24 Vdc	Control voltage for D11–D15	Maximum load 100 mA Reference potential V
2	D11	Digital Input 1	Start Enable FWD ①
3	D12	Digital Input 2	Start Enable REV ①
4	D13	Digital Input 3	Fixed frequency FF1/FF2 ①
5	+10 Vdc	Reference voltage, Output (+10V)	Maximum load 10 mA Reference potential 0V
6	A11	Analog Input 1	Frequency reference value ①
	D14	Digital Input 5	Frequency reference value ①
7	0V	Reference potential	0V = connection terminal 9
8	A01	Analog Output 1	Output frequency
	D01	Digital Output 1	Output frequency
9	0V	Reference potential	0V connection terminal 7
10	D14	Digital Input 4	Fixed frequency FF2 ①
	A12	Analog Input 2	Fixed frequency FF2 ①
11	A02	Analog output 2	Output current ①
	D02	Digital output 2	Output current ①
12	STO+	Safe Torque Off +	Enable = +24V
13	STO-	Safe Torque Off -	Enable = 0V
14	K11	Relay 1, changeover contact	Active = FAULT ①
15	K14	Relay 1, changeover contact (N/O)	Active = FAULT ①
16	K12	Relay 1, changeover contact (N/C)	Active = FAULT ①
17	K23	Relay 2, N/O contact	Active = FAULT ①
18	K24	Relay 2, N/C contact	Active = FAULT ①

Note

① Programmable function.

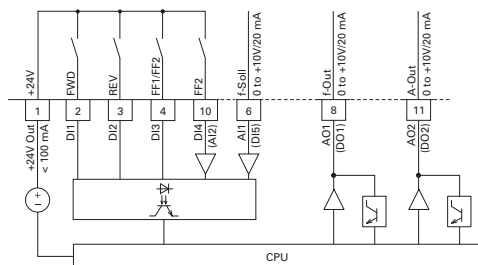

2.2

Adjustable Frequency Drives

PowerXL DC1, DA1 Series Adjustable Frequency AC Drives

Dimensions

Approximate Dimensions in Inches (mm)

2 DC1, Sizes FS1–FS3, Degree of Protection IP20/NEMA 0

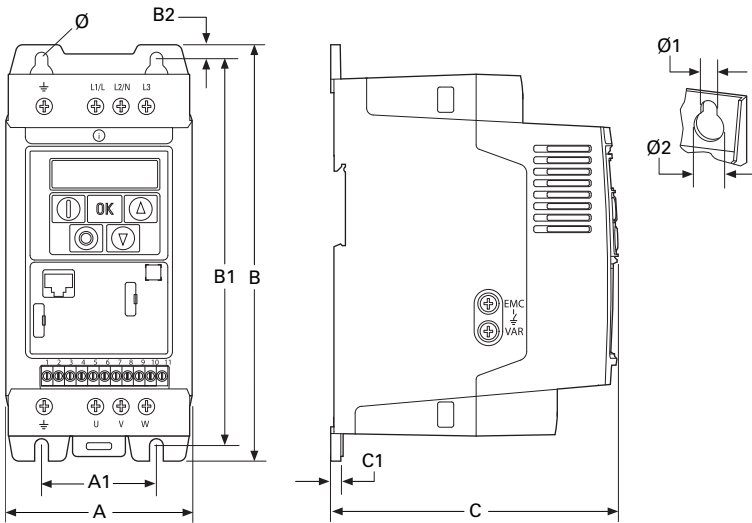

Frame Size	A	A1	B	B1	B2	C	C1	Ø1	Ø2	Weight lbs (kg)
FS1	3.19 (81.0)	1.97 (50.0)	7.24 (184.0)	6.69 (170.0)	0.28 (7.0)	4.88 (124.0)	0.16 (4.0)	0.24 (6.0)	0.47 (12.0)	2.43 (1.1)
FS2	4.21 (107.0)	2.95 (75.0)	9.09 (231.0)	8.46 (215.0)	0.31 (8.0)	5.98 (152.0)	0.20 (5.0)	0.24 (6.0)	0.47 (12.0)	5.73 (2.6)
FS3	5.16 (131.0)	3.94 (100.0)	10.75 (273.0)	10.04 (255.0)	0.33 (8.5)	6.89 (175.0)	0.20 (5.0)	0.24 (6.0)	0.47 (12.0)	8.82 (4.0)

DA1, Sizes FS2 and FS3, Degree of Protection IP20/NEMA 0

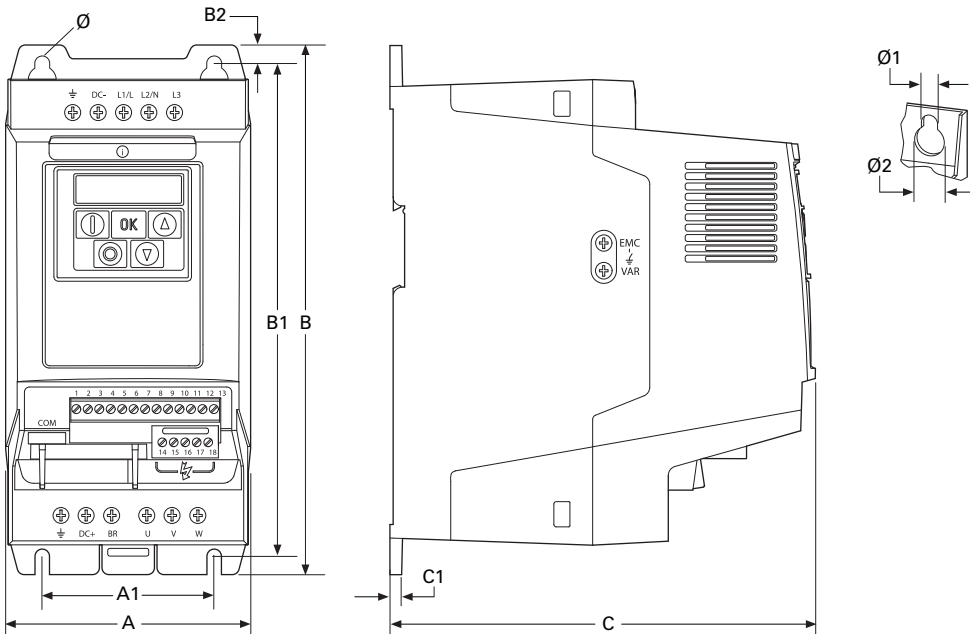

Frame Size	A	A1	B	B1	B2	C	C1	Ø1	Ø2	Weight lbs (kg)
FS2	4.21 (107.0)	2.95 (75.0)	9.09 (231.0)	8.46 (215.0)	0.31 (8.0)	7.32 (186.0)	0.20 (5.0)	0.24 (6.0)	0.47 (12.0)	3.97 (1.8)
FS3	5.16 (131.0)	3.94 (100.0)	10.75 (273.0)	10.04 (255.0)	0.33 (8.5)	8.03 (204.0)	0.20 (5.0)	0.24 (6.0)	0.47 (12.0)	7.72 (3.5)