

PLEASE CHECK WWW.MOLEX.COM FOR LATEST PART INFORMATION

Part Number: **0190020010**
Status: **Active**
Overview: Standard Quick-Disconnect Terminals
Description: Avikrimp™ Fully Insulated Quick Disconnect, Female, for 18-22 AWG Wire, Mylar Tape

Documents:

3D Model	Product Specification PS-19902-014 (PDF)
Drawing (PDF)	Product Specification PS-19902-015 (PDF)
Product Specification PS-19902-011 (PDF)	RoHS Certificate of Compliance (PDF)

Agency Certification

CSA	LR18689
UL	E79133

General

Product Family	Quick Disconnects
Series	<u>19002</u>
Crimp Quality Equipment	Yes
Insulated	Fully
Overview	<u>Standard Quick-Disconnect Terminals</u>
Product Name	Avikrimp™
Type	Quick Disconnect
UPC	800753027046

Physical

Barrel Type	Closed
Color - Resin	Red
Flammability	94V-2
Gender	Female
Glow-Wire Compliant	Yes
Insulation	Nylon (PA)
Lock to Mating Part	None
Material - Metal	Brass
Material - Plating Mating	Tin
Material - Plating Termination	Tin
Net Weight	0.849/g
Orientation	Straight
Packaging Type	Adhesive Tape on Reel
Polarized to Mating Part	No
Tab Thickness	0.81mm
Tab Width	4.75mm
Temperature Range - Operating	-65°C to +105°C
Wire Insulation Diameter	3.17mm max.
Wire Size AWG	18, 20, 22

Electrical

Voltage - Maximum	300V
-------------------	------

Solder Process Data

Lead-free Process Capability	N/A
------------------------------	-----

Material Info

Old Part Number	AA-5271T
-----------------	----------

Reference - Drawing Numbers

Product Specification	PS-19902-011, PS-19902-014, PS-19902-015
Sales Drawing	SD-19002-003

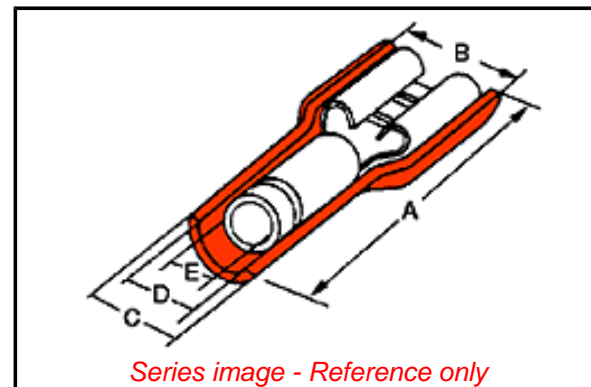

Series image - Reference only

EU ELV

Not Relevant

EU RoHS

Compliant

REACH SVHC

Not Contained Per -
ED/39/2015 (15 June
2015)

Halogen-Free

Status

Low-Halogen

**Need more information on product
environmental compliance?**

Email productcompliance@molex.com
Please visit the [Contact Us](#) section for any
non-product compliance questions.

China ROHS

ELV

Green Image

Not Relevant

Search Parts in this Series

19002 Series

Application Tooling | FAQ

*Tooling specifications and manuals are
found by selecting the products below.
Crimp Height Specifications are then
contained in the Application Tooling
Specification document.*

Global

Description	Product #
Mini-Mac™ Applicator	<u>0638852000</u>
ATP Crimp Dies for the Tape Crimp Module and ATP-101 & 301 Press	<u>0192880028</u>

This document was generated on 03/01/2016

PLEASE CHECK WWW.MOLEX.COM FOR LATEST PART INFORMATION