



Battery Disconnect Switch

DESCRIPTION

The Si4720CY is two level-shifted P-Channel MOSFETs. Operating together, these MOSFETs can be used as a reverse blocking switch for battery disconnect applications. It is a solution for multiple battery technology designs or designs that require isolation from the power bus during charging.

The Si4720CY is available in a 16-pin SOIC package and is rated for the commercial temperature range of - 25 °C to 85 °C.

FEATURES

- Solution for Bi-Directional Blocking
- 6 V to 30 V Operation
- Ground Referenced Logic Level Inputs
- Integrated Low $R_{DS(on)}$ MOSFET
- Level-Shifted Gate Drive with Internal MOSFET
- Two Independent Inputs
- Ultra Low Power Consumption in Off State (Leakage Current Only)
- Logic Supply Voltage is Not Required

FUNCTIONAL BLOCK DIAGRAM

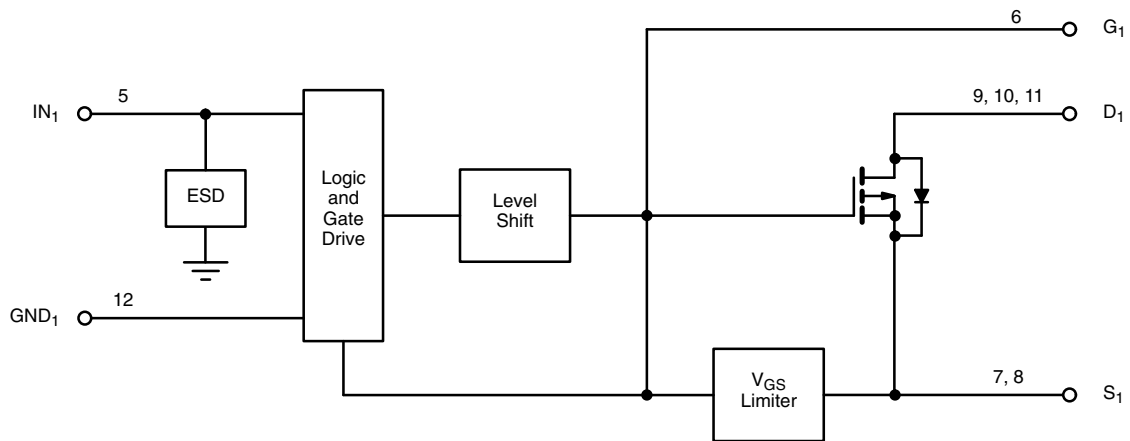

Half a circuit shown here.

Si4720

Vishay Siliconix

**ABSOLUTE MAXIMUM RATINGS**

Parameter	Symbol	Limit	Unit
Voltage Referenced to GND V_S, V_D^a		- 0.3 to 32	V
V_{SD}		- 0.3 to 30	
V_{IN1}, V_{IN2}		- 0.3 to 15	
V_{GS}		20	
Storage Temperature		- 55 to 150	°C
Power Dissipation ^b	$t = 10$ s	2.5	W
	$t =$ Steady State	1.5	

Notes:

a. $V_{SD} \leq 30 V_{DC}$.

b. Device mounted with all leads soldered to 1" x 1" FR4 with laminated copper PC board.

Stresses beyond those listed under "Absolute Maximum Ratings" may cause permanent damage to the device. These are stress ratings only, and functional operation of the device at these or any other conditions beyond those indicated in the operational sections of the specifications is not implied. Exposure to absolute maximum rating conditions for extended periods may affect device reliability.

RECOMMENDED OPERATING RANGE

Parameter	Symbol	Limit	Unit
V_S, V_D		6 to 30	V
V_{IN1}, V_{IN2}		0 to 13.2	
I_{DS}		0 to 6	A
Operating Temperature Range		- 25 to 85	°C
Junction Temperature		- 25 to 150	

This device has a maximum recommended operating junction temperature of 85 °C. This temperature limit is used for electrical specifications such as logic transition voltages only and is not a reliability limit. The device can be used with junction temperatures up to 150 °C if relaxed specifications can be tolerated, although limits for these specifications may not be given. Performance curves can be used to give an indication of specifications at higher temperatures, but are not guaranteed.

SPECIFICATIONS

Parameter	Symbol	Test Conditions Unless Otherwise Specified	Limits				Unit
			Temp. ^a	Min. ^b	Typ. ^c	Max. ^b	
On-Resistance	r_{DS}	$V_S = 10$ V, $I_D = 1$ A, $V_{IN} = H$	Room		0.0155	0.020	Ω
Leakage Current	$I_{DS(off)}$	$V_{DS} = 10$ V	Room			1	μ A
Supply Current	$I_{S(off)}$	$V_S = 21$ V	Room			1	
	$I_{S(on)}$		Room		1.1	6	
Input Voltage Low	V_{INL}	$V_S = 10$ and $V_S = 21$	Full			1	V
Input Voltage High	V_{INH}		Full	2.5			
Input Leakage Current	I_{INH}	$V_{IN} = 5$ V	Full			5	μ A
Turn-On Delay	IN to D or S	$V_S = 10$ V, $R_L = 5$ Ω , Figure 1	Room	2.2	2.9	10	μ s
Turn-Off Delay			Room		1.5	2.1	
Break-Before-Make ^d	t_{BBM}		Room		1.05		
Rise Time	t_{RISE}	$V_S = 10$ V, $R_L = 5$ Ω , Figure 1	Room		1.3	2.5	
Fall Time	t_{FALL}		Room		50	100	ns
Voltage Across pin 6 and 7	V_{GS}	$V_S = 30$	Room		10.2	18	V
Forward Diode	V_{SD}	$I_D = -1$ A	Room			1.1	

Notes:

a. Room = 25 °C, full = as determined by the operating temperature suffix.

b. The algebraic convention whereby the most negative value is a minimum and the most positive a maximum.

c. Typical values are for DESIGN AID ONLY, not guaranteed nor subject to production testing.

d. Guaranteed by design, not subject to production testing.



TIMING DIAGRAMS

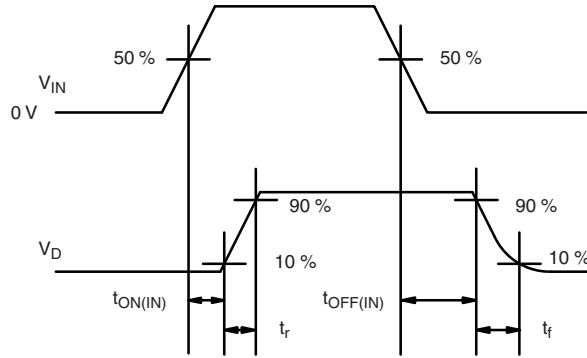
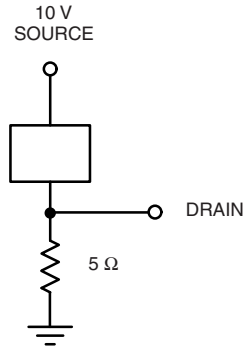
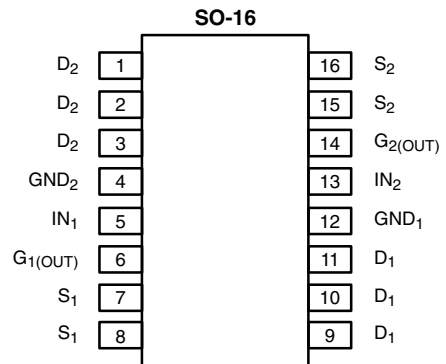

Figure 1.

PIN CONFIGURATION AND TRUTH			
V _{IN1}	V _{IN2}	Switch 1	Switch 2
0	0	Off	Off
0	1	Off	On
1	0	On	Off
1	1	On	On



Top View

Order Number: Si4720CY

PIN DESCRIPTION (Subject to Change)		
Pin Number	Symbol	Description
1, 2, 3	D ₂	Drain connection for MOSFET-2.
4, 12	GND	Ground
5	IN ₁	Logic input, IN ₁ . High level turns on the switch.
6	G _{1(OUT)}	Gate output to MOSFET-1.
7, 8	S ₁	Source connection for MOSFET-1.
9, 10, 11	D ₁	Drain connection for MOSFET-1.
13	IN ₂	Logic input, IN ₂ . High level turns on the switch.
14	G _{2(OUT)}	Gate output to MOSFET-2.
15, 16	S ₂	Source connection for MOSFET-2.

Si4720



Vishay Siliconix

TYPICAL CHARACTERISTICS (25 °C unless noted)

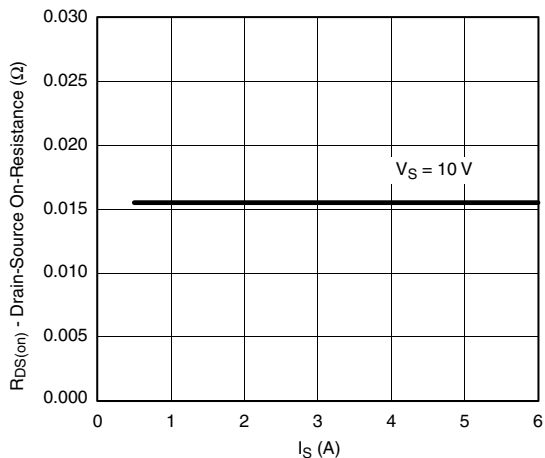

On-Resistance vs. Drain Current

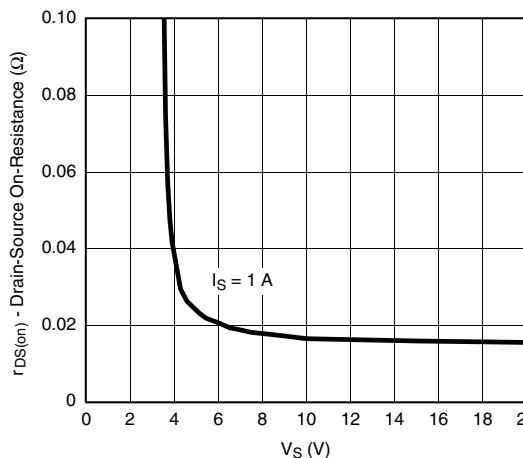

On-Resistance vs. Source Voltage

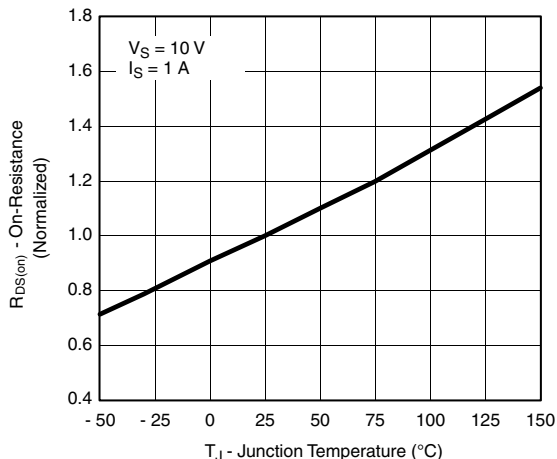

Normalized On-Resistance vs. Junction Temperature

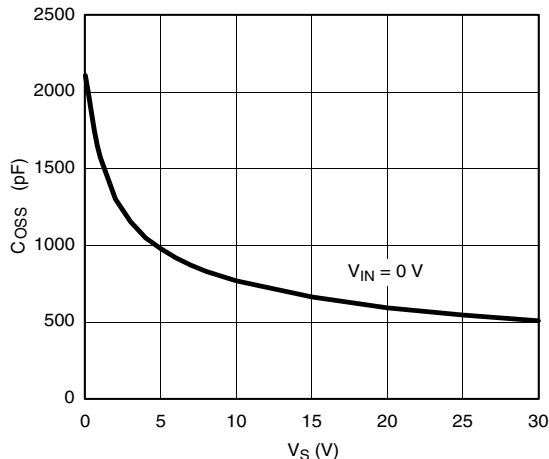

Output Capacitance vs. Source Voltage

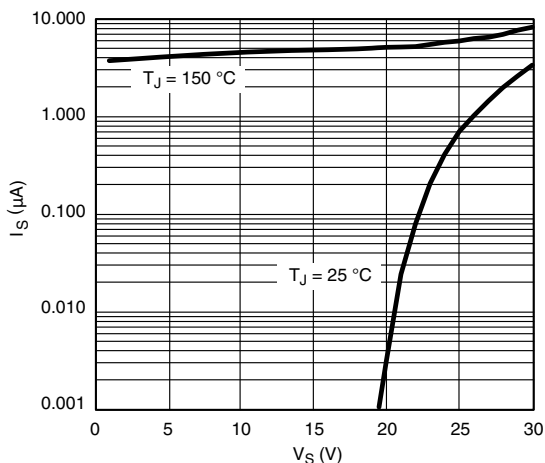

Off-Supply Current vs. Source Voltage

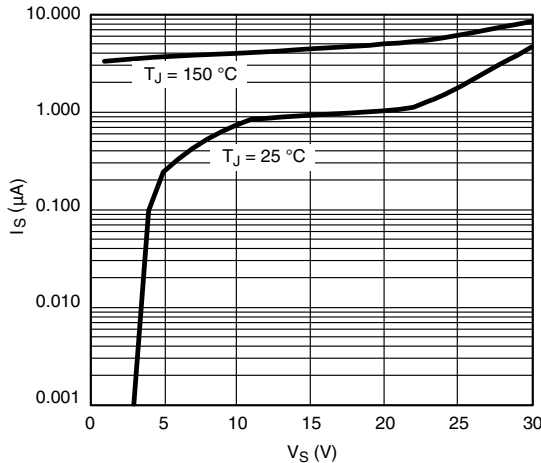

On-Supply Current vs. Source Voltage



TYPICAL CHARACTERISTICS (25 °C unless noted)

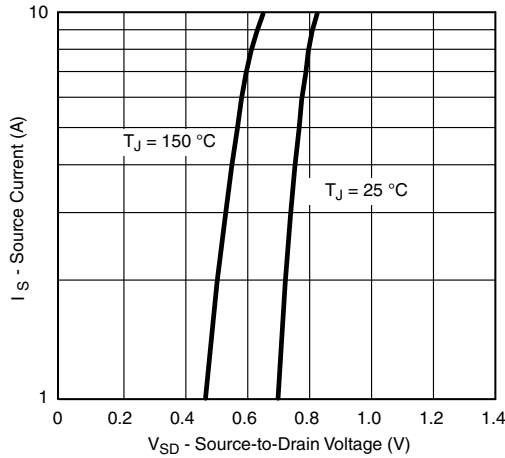

Drain-Source Diode Forward Voltage

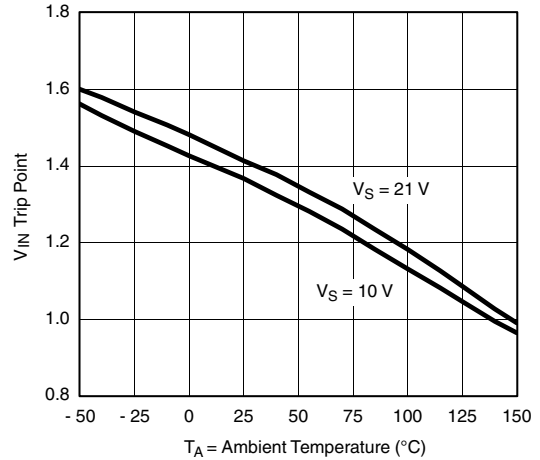

Input Voltage Trip Point vs. Temperature

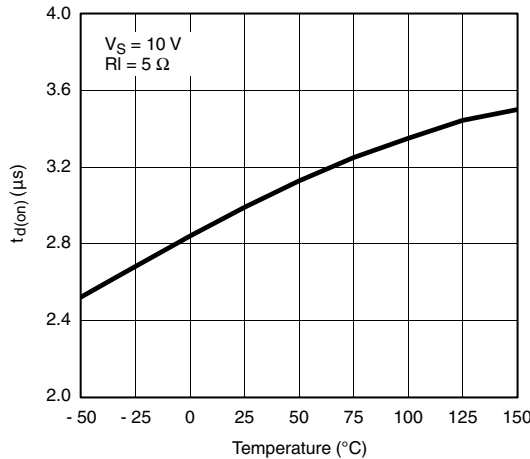

Turn-On Delay vs. Temperature

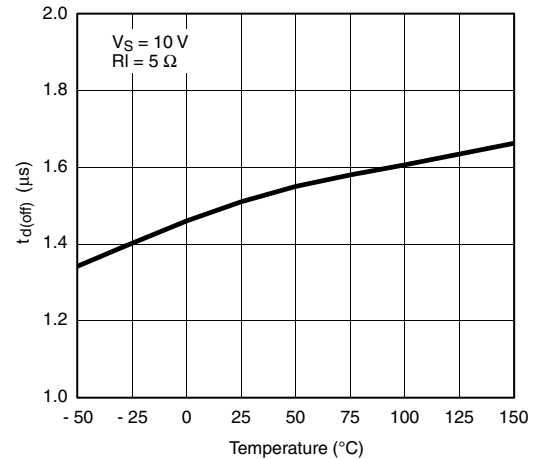

Turn-off Delay vs. Temperature

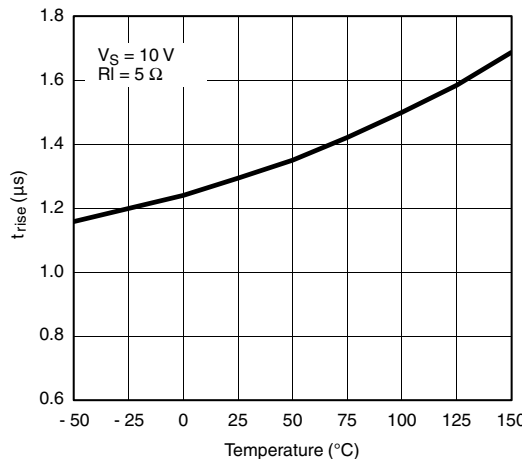

Rise Time vs. Temperature

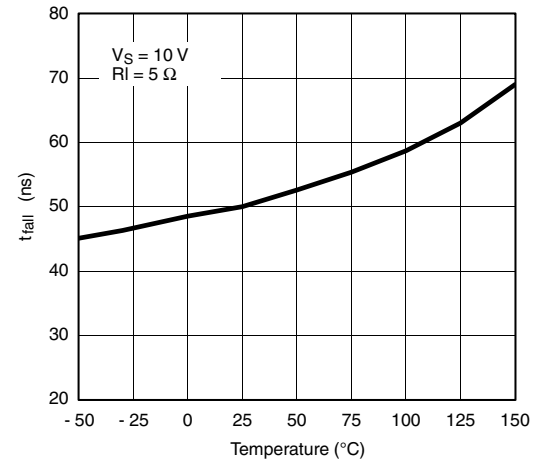

Fall Time vs. Temperature

Si4720

Vishay Siliconix



TYPICAL CHARACTERISTICS (25 °C unless noted)

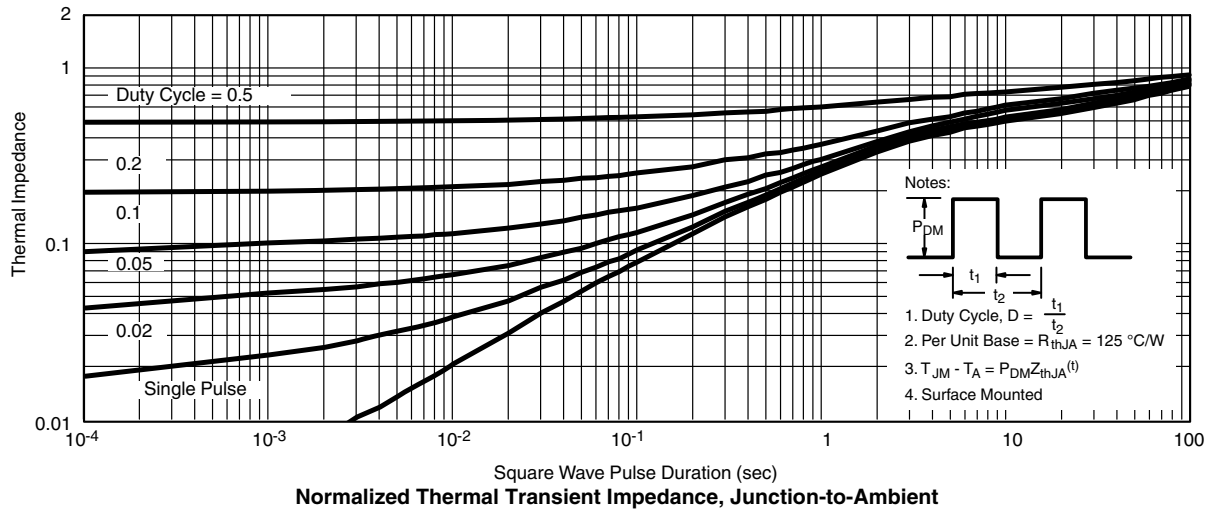
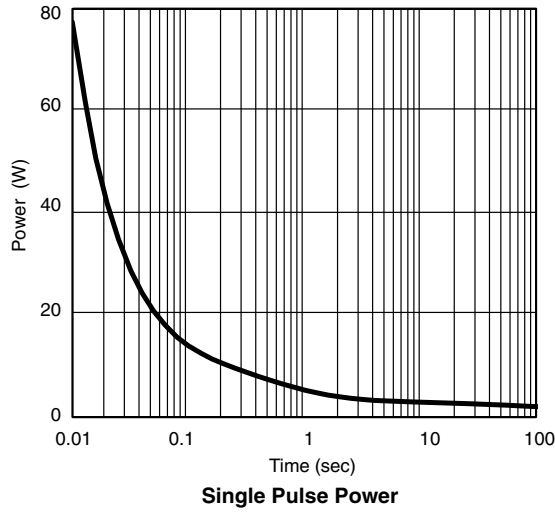



APPLICATION DRAWINGS

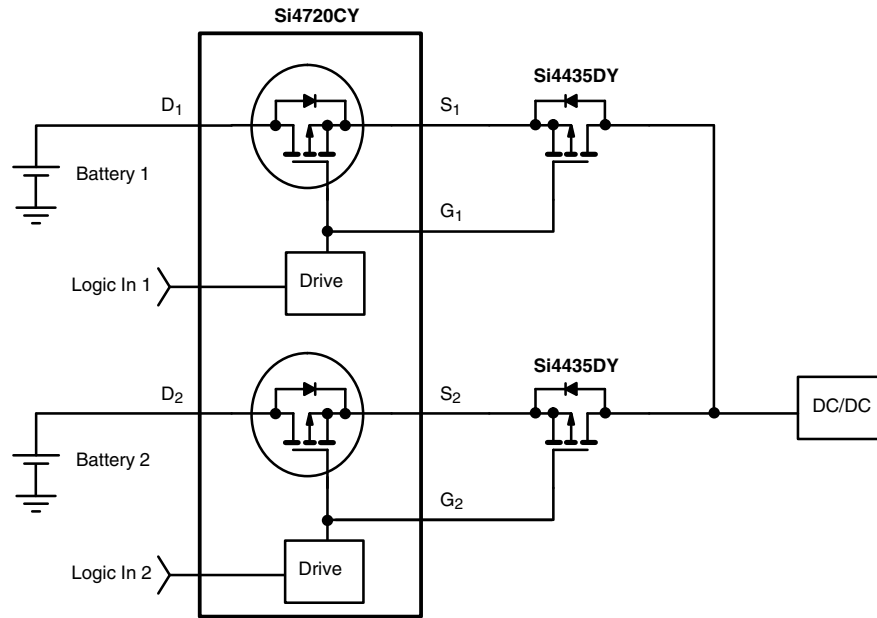

Figure 2.

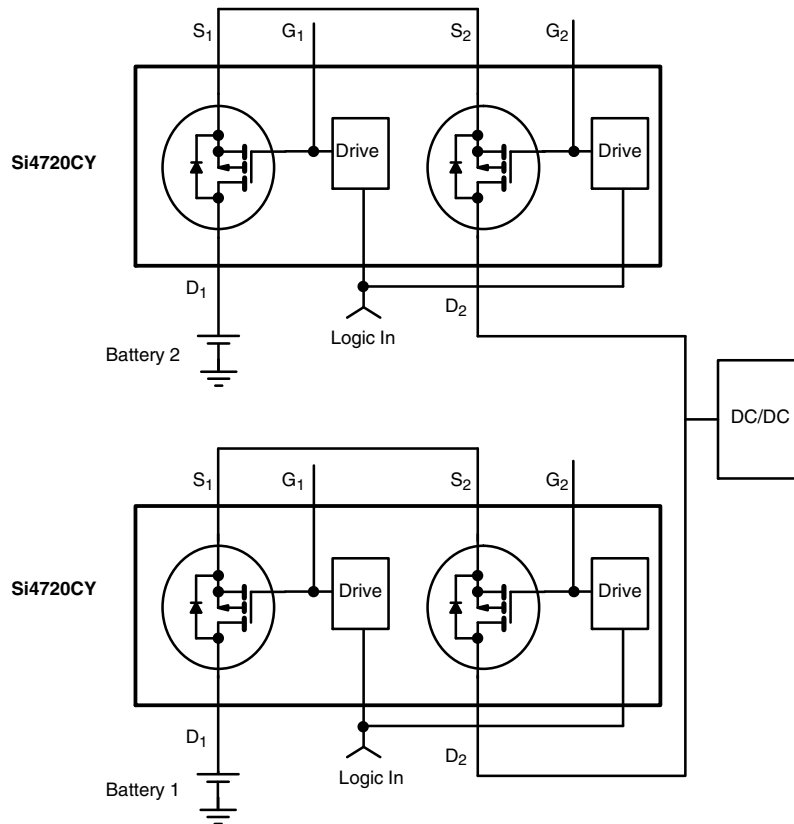

Figure 3.

Si4720

Vishay Siliconix



APPLICATION DRAWINGS

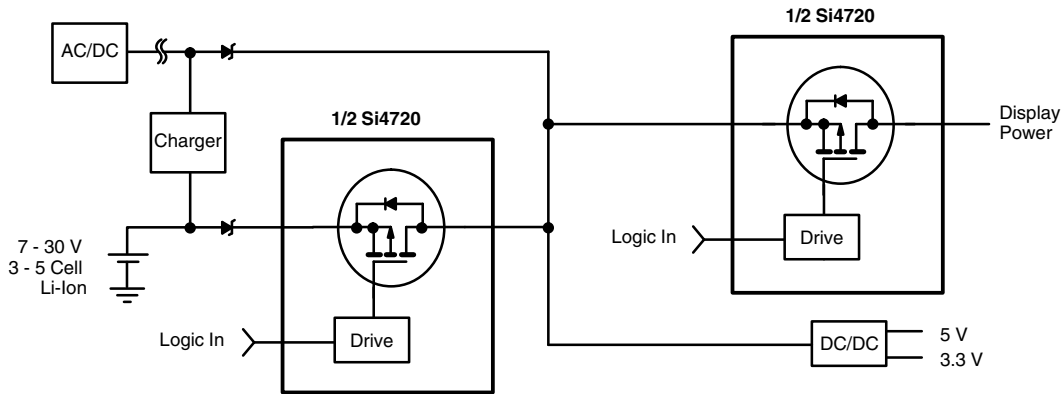

Figure 4. Low-Cost Laptop PC

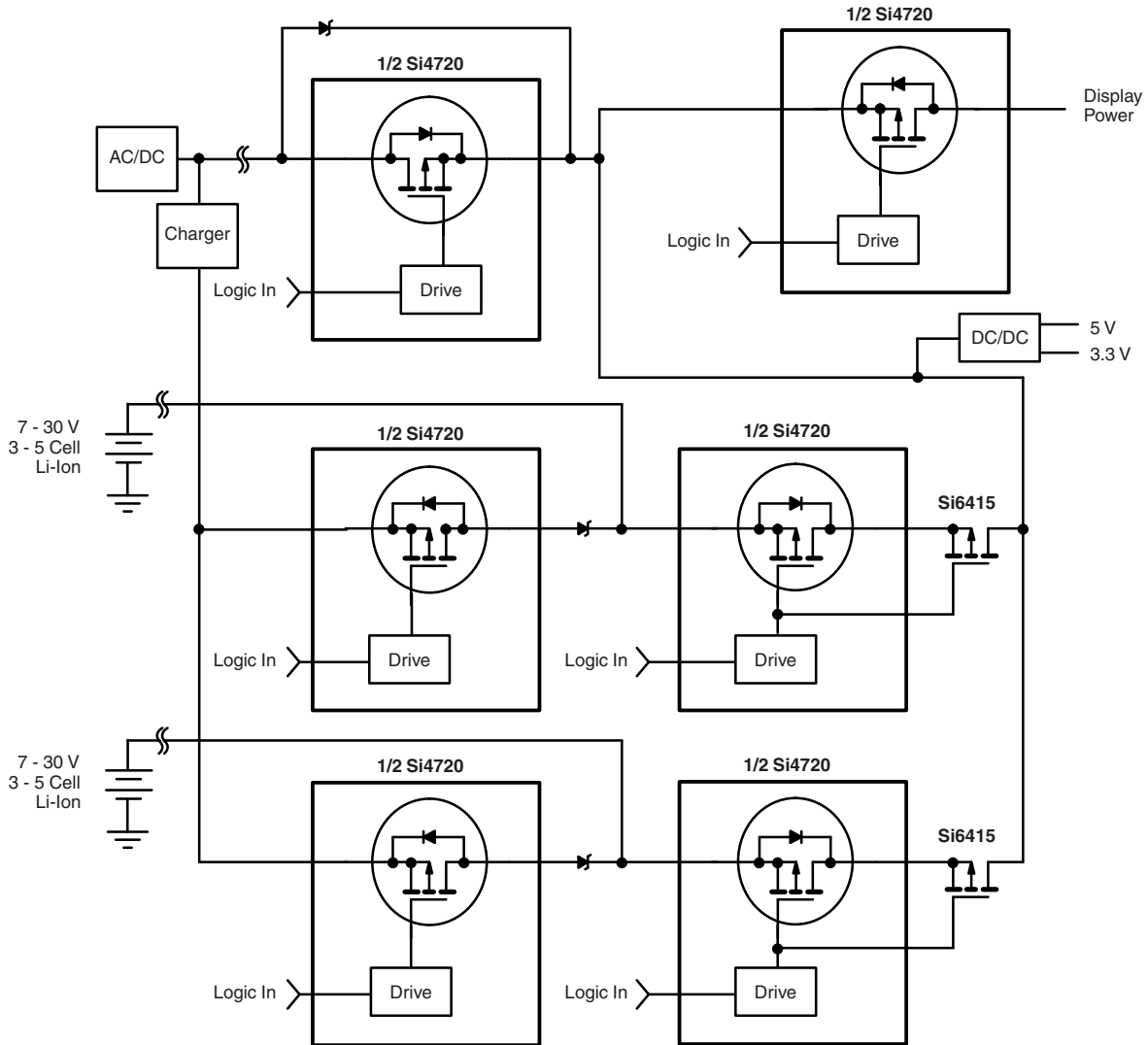

Figure 5. High-Performance Laptop PC

Vishay Siliconix maintains worldwide manufacturing capability. Products may be manufactured at one of several qualified locations. Reliability data for Silicon Technology and Package Reliability represent a composite of all qualified locations. For related documents such as package/tape drawings, part marking, and reliability data, see www.vishay.com/ppg?70664.



SOIC (NARROW): 16-LEAD
JEDEC Part Number: MS-012



Dim	MILLIMETERS		INCHES	
	Min	Max	Min	Max
A	1.35	1.75	0.053	0.069
A ₁	0.10	0.20	0.004	0.008
B	0.38	0.51	0.015	0.020
C	0.18	0.23	0.007	0.009
D	9.80	10.00	0.385	0.393
E	3.80	4.00	0.149	0.157
e	1.27 BSC		0.050 BSC	
H	5.80	6.20	0.228	0.244
L	0.50	0.93	0.020	0.037
∅	0°	8°	0°	8°

ECN: S-03946—Rev. F, 09-Jul-01
DWG: 5300





Disclaimer

ALL PRODUCT, PRODUCT SPECIFICATIONS AND DATA ARE SUBJECT TO CHANGE WITHOUT NOTICE TO IMPROVE RELIABILITY, FUNCTION OR DESIGN OR OTHERWISE.

Vishay Intertechnology, Inc., its affiliates, agents, and employees, and all persons acting on its or their behalf (collectively, "Vishay"), disclaim any and all liability for any errors, inaccuracies or incompleteness contained in any datasheet or in any other disclosure relating to any product.

Vishay makes no warranty, representation or guarantee regarding the suitability of the products for any particular purpose or the continuing production of any product. To the maximum extent permitted by applicable law, Vishay disclaims (i) any and all liability arising out of the application or use of any product, (ii) any and all liability, including without limitation special, consequential or incidental damages, and (iii) any and all implied warranties, including warranties of fitness for particular purpose, non-infringement and merchantability.

Statements regarding the suitability of products for certain types of applications are based on Vishay's knowledge of typical requirements that are often placed on Vishay products in generic applications. Such statements are not binding statements about the suitability of products for a particular application. It is the customer's responsibility to validate that a particular product with the properties described in the product specification is suitable for use in a particular application. Parameters provided in datasheets and/or specifications may vary in different applications and performance may vary over time. All operating parameters, including typical parameters, must be validated for each customer application by the customer's technical experts. Product specifications do not expand or otherwise modify Vishay's terms and conditions of purchase, including but not limited to the warranty expressed therein.

Except as expressly indicated in writing, Vishay products are not designed for use in medical, life-saving, or life-sustaining applications or for any other application in which the failure of the Vishay product could result in personal injury or death. Customers using or selling Vishay products not expressly indicated for use in such applications do so at their own risk. Please contact authorized Vishay personnel to obtain written terms and conditions regarding products designed for such applications.

No license, express or implied, by estoppel or otherwise, to any intellectual property rights is granted by this document or by any conduct of Vishay. Product names and markings noted herein may be trademarks of their respective owners.

Material Category Policy

Vishay Intertechnology, Inc. hereby certifies that all its products that are identified as RoHS-Compliant fulfill the definitions and restrictions defined under Directive 2011/65/EU of The European Parliament and of the Council of June 8, 2011 on the restriction of the use of certain hazardous substances in electrical and electronic equipment (EEE) - recast, unless otherwise specified as non-compliant.

Please note that some Vishay documentation may still make reference to RoHS Directive 2002/95/EC. We confirm that all the products identified as being compliant to Directive 2002/95/EC conform to Directive 2011/65/EU.

Vishay Intertechnology, Inc. hereby certifies that all its products that are identified as Halogen-Free follow Halogen-Free requirements as per JEDEC JS709A standards. Please note that some Vishay documentation may still make reference to the IEC 61249-2-21 definition. We confirm that all the products identified as being compliant to IEC 61249-2-21 conform to JEDEC JS709A standards.