



ATTENTION
OBSERVE PRECAUTIONS
FOR HANDLING
ELECTROSTATIC
DISCHARGE
SENSITIVE
DEVICES

Part Number: KADS-8072SY9Z4S Super Bright Yellow

Features

- High efficient light source.
- Designed for high current operation.
- Low thermal resistance.
- Encapsulation : Silicone resin.
- Compatible with IR-reflow processes.
- Moisture sensitivity level : level 4.
- ESD protection.
- RoHS compliant.

Applications

- Substitution of micro incandescent lamps.
- Portable light source.
- Signal and symbol luminaire for orientation.
- Marker lights (e.g. steps, exit ways, etc).
- Decorative and entertainment lighting.
- Commercial and residential lighting.
- Emergency-vehicle lighting.

Application Note

Static electricity and surge damage the LEDs.

It is recommended to use a wrist band or anti-electrostatic glove when handling the LEDs.

All devices, equipment and machinery must be electrically grounded.

Package Dimensions

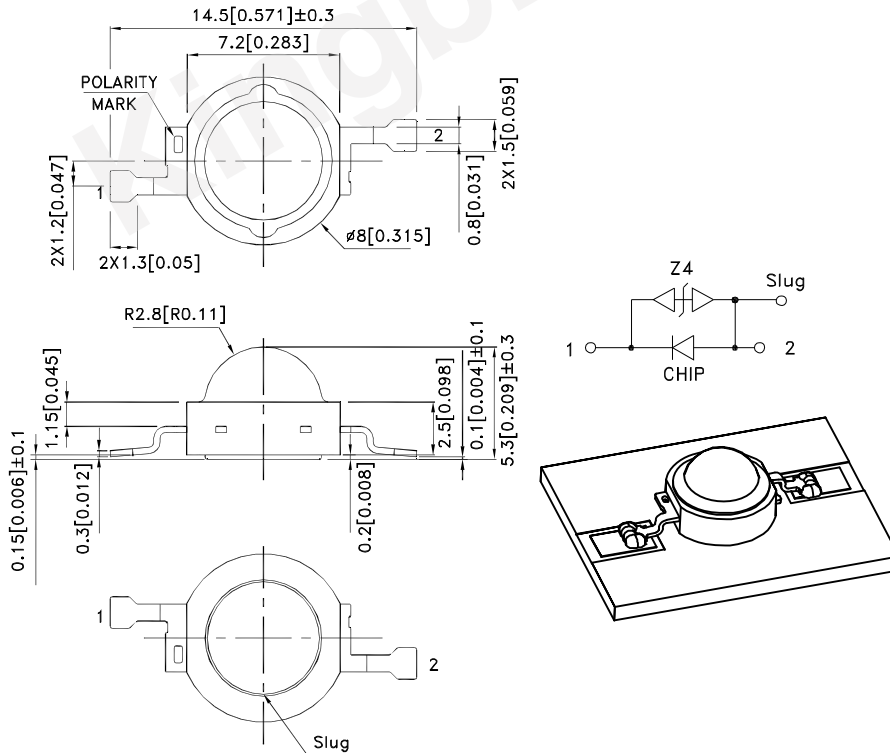

Notes:

1. All dimensions are in millimeters (inches).
2. Tolerance is $\pm 0.25(0.01)$ unless otherwise noted.
3. The specifications, characteristics and technical data described in the datasheet are subject to change without prior notice.
4. The device has a single mounting surface. The device must be mounted according to the specifications.



Handling Precautions

Compare to epoxy encapsulant that is hard and brittle, silicone is softer and flexible. Although its characteristic significantly reduces thermal stress, it is more susceptible to damage by external mechanical force.

As a result, special handling precautions need to be observed during assembly using silicone encapsulated LED products. Failure to comply might lead to damage and premature failure of the LED.

1. Handle the component along the side surfaces by using forceps or appropriate tools.

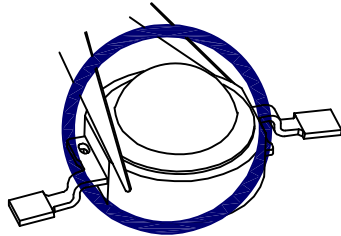

2. Do not directly touch or handle the silicone lens surface. It may damage the internal circuitry.

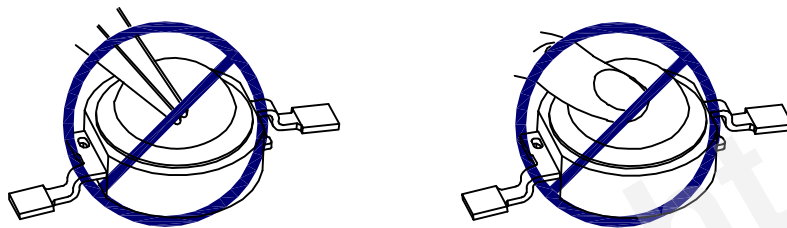

3. Do not stack together assembled PCBs containing exposed LEDs. Impact may scratch the silicone lens or damage the internal circuitry.

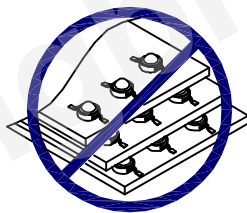

4.1. There should be enough space inside the nozzle to avoid contact with the dome lens during pick up.

4.2. The inner diameter of the SMD pickup nozzle should not exceed the size of the LED to prevent air leaks.

4.3. A pliable material is suggested for the nozzle tip to avoid scratching or damaging the LED surface during pickup.

4.4. The dimensions of the component must be accurately programmed in the pick-and-place machine to insure precise pickup and avoid damage during production.

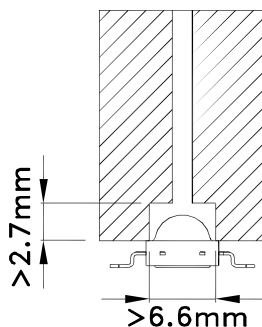

5. As silicone encapsulation is permeable to gases, some corrosive substances such as H₂S might corrode silver plating of Leadframe. Special care should be taken if an LED with silicone encapsulation is to be used near such substances.

Detailed application notes are listed on our website.

http://www.kingbright.com/application_notes

Flux Characteristics at 350mA Ambient Temperature, $T_a = 25^\circ\text{C}$

Color	Part No.	Luminous Flux (lm) @ 350mA [1]			
		Code.	Min.	Max.	Typ.
Super Bright Yellow (AlGaInP)	KADS-8072SY9Z4S	B7	29	35	42
		B8	35	42	
		B9	42	50	
		B10	50	60	

Note:

1. Minimum luminous flux performance guaranteed within published operating conditions. Kingbright maintains tolerance of +/-15% on flux.
2. Luminous Flux value is traceable to the CIE127-2007 compliant national standards.

Optical Characteristics at 350mA Ambient Temperature, $T_a = 25^\circ\text{C}$

Color	Dominant Wavelength [1] λ_D (nm)			Typical Spectral Halfwidth [2] (nm) $\Delta\lambda_{1/2}$	Typical Temperature Coefficient of Dominant Wavelength (nm/ $^\circ\text{C}$) $\Delta\lambda_D/\Delta T$	Typical Viewing Angle [3] (degrees) $2\theta_{1/2}$
	Min.	Typ.	Max.			
Super Bright Yellow	584	591	594	23	0.07	150°

Notes:

1. Dominant wavelength is derived from the CIE 1931 Chromaticity diagram and represents the perceived color.
2. Spectral width at 1/2 of the peak intensity.
3. Viewing angle is the off axis angle from lamp centerline where the luminous intensity is 1/2 of the peak value.
4. Wavelength value is traceable to the CIE127-2007 compliant national standards.

Electrical Characteristics at 350mA Ambient Temperature, $T_a = 25^\circ\text{C}$

Color	Forward Voltage V_f [1] (V)			Typical Temperature Coefficient of Forward Voltage [2] (mV/ $^\circ\text{C}$) $\Delta V_f/\Delta T$	Typical Thermal Resistance ($^\circ\text{C}/\text{W}$) $R_{th\ j\text{-slug}}$
	Min.	Typ.	Max.		
Super Bright Yellow	1.8	2.3	2.8	-3.2	5

Notes:

1. Kingbright maintains a tolerance of +/- 0.1V on forward voltage measurements.
3. Measured between $25^\circ\text{C} \leq T_j \leq 110^\circ\text{C}$ at $I_F = 350\text{ mA}$.

Absolute Maximum Ratings

Parameter	Super Bright Yellow
DC Forward Current (mA) [1]	500
Peak Pulsed Forward Current (mA)	700
Average Forward Current (mA)	500
Reverse Voltage (V)	5
ESD Sensitivity	8000V HBM
LED Junction Temperature (°C)	110
Operation Temperature (°C)	-40 to+100
Storage Temperature (°C)	-40 to+110
Soldering Temperature (°C)	260 For 5 Seconds

Notes:

1. Proper current derating must be observed to maintain junction temperature below the maximum.

Wavelength Characteristics $T_a = 25^\circ\text{C}$

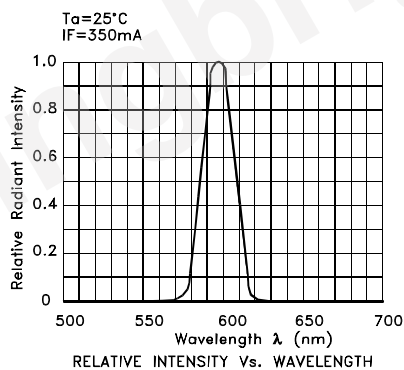

Light Output Characteristics

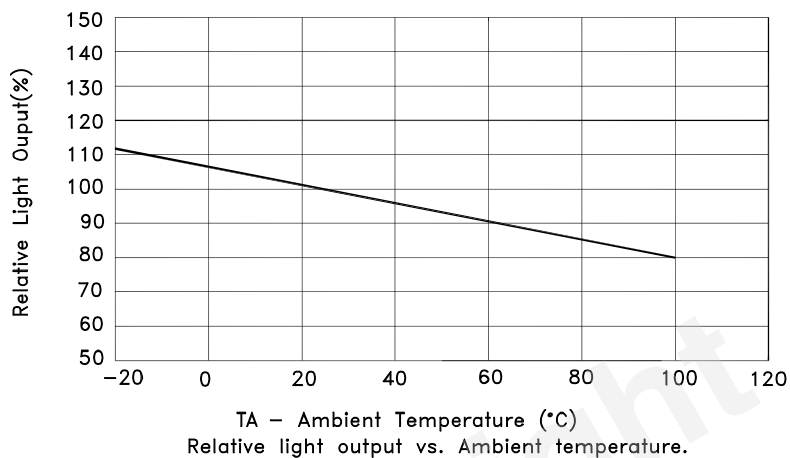

Forward Current Characteristics, TA=25°C

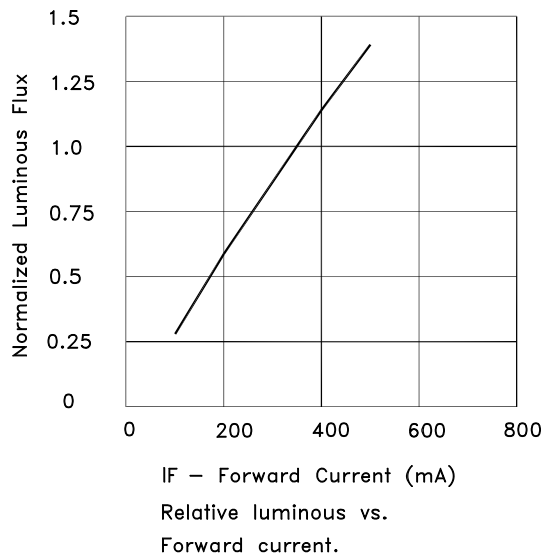
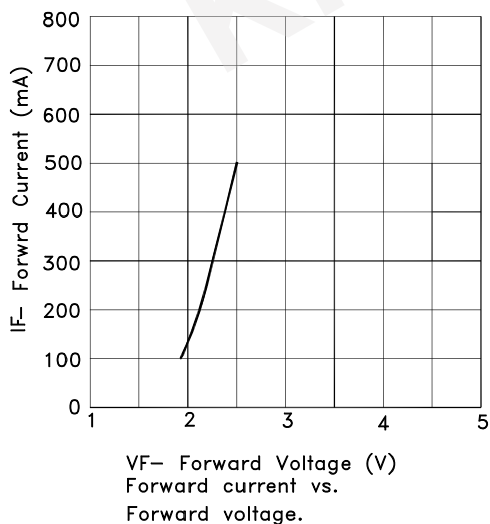

Current Derating Curves

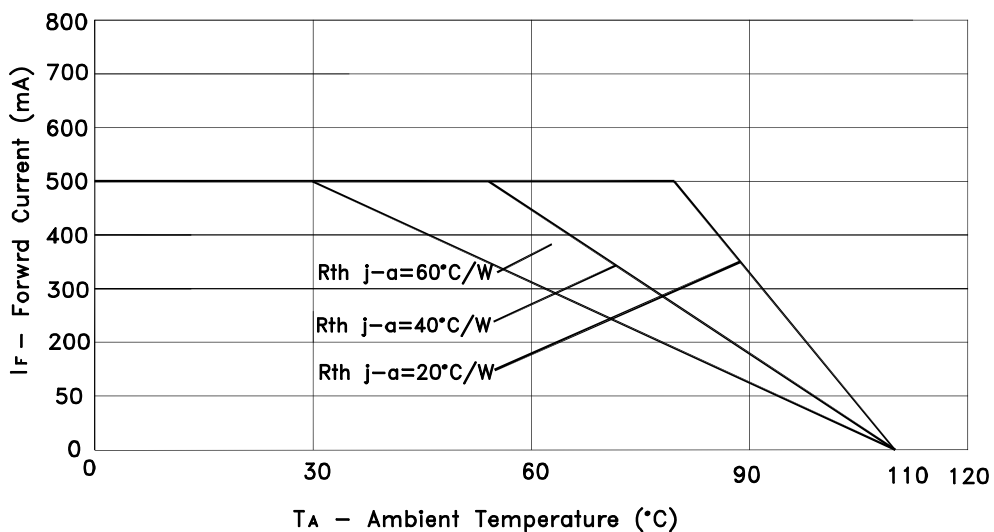

Maximum forward current vs. ambient temperature, based on $T_{JMAX} = 110^{\circ}C$.

Representative Typical Spatial Radiation Pattern

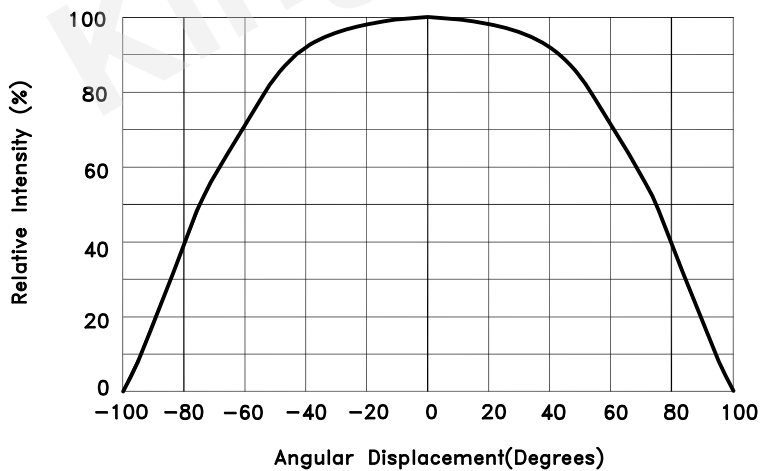

Representative Typical Spatial Radiation Pattern .

Reflow soldering is recommended and the soldering profile is shown below.
Other soldering methods are not recommended as they might cause damage to the product.

Reflow Soldering Profile For Lead-free SMT Process.

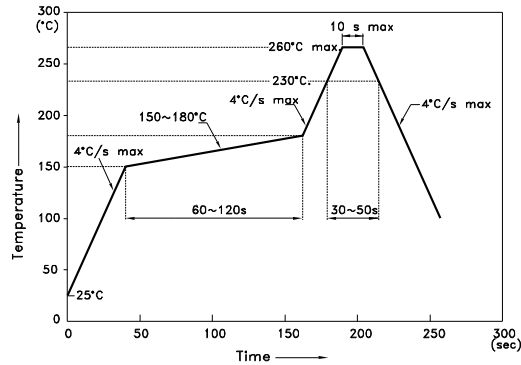

NOTES:

1. We recommend the reflow temperature 245°C(+/-5°C). The maximum soldering temperature should be limited to 260°C.
2. Don't cause stress to the epoxy resin while it is exposed to high temperature.
3. Number of reflow process shall be 2 times or less.

Recommended Soldering Pattern
(Units : mm ; Tolerance: ± 0.1)

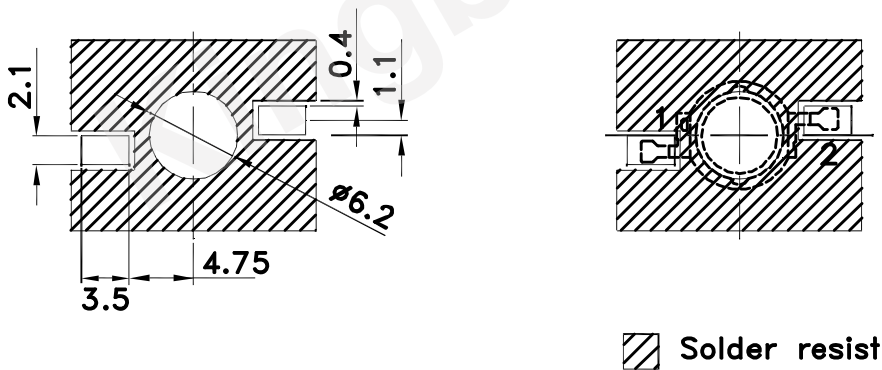

1. Solder pad dimensions are as shown above.
2. Recommended solder paste stencil pattern dimensions:
 - The center circular opening of the stencil (for the heat slug) should have the same size as the solder pad.
 - Each side of the two rectangular openings (for the leads) should exceed those of the solder pads by 0.06 – 0.10 mm.
 - Solder paste thickness should be greater than 0.25 mm.

PACKING & LABEL SPECIFICATIONS

KADS-8072SY9Z4S

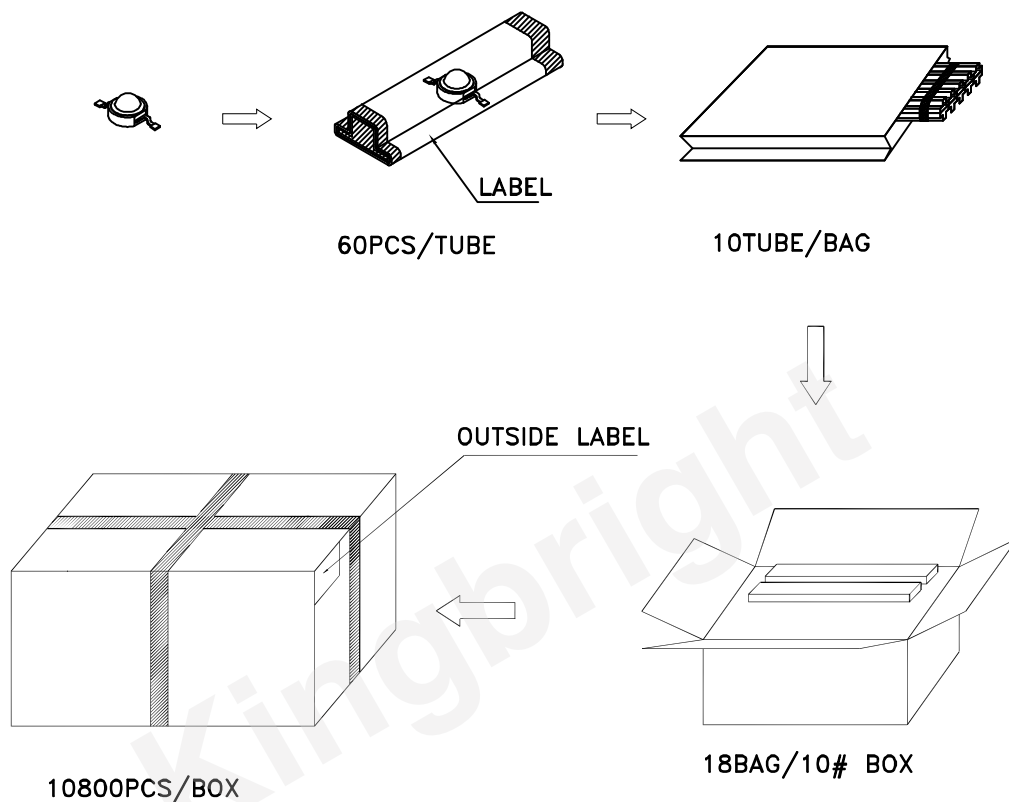

Kingbright	
P/NO: KADS-8072xxx	
QTY: 600 pcs	Q.C. Q C XX XX XXXX PASSED
S/N: XXXX	
CODE: XXX	
LOT NO:	
 XXXXXXXXXXXXX	
RoHS Compliant	