

10C - 12C series

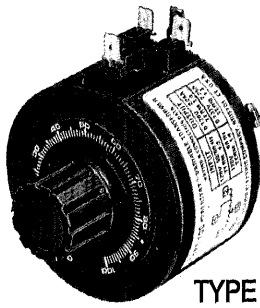

TYPE 10C

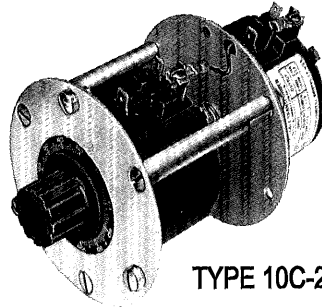

TYPE 10C-2

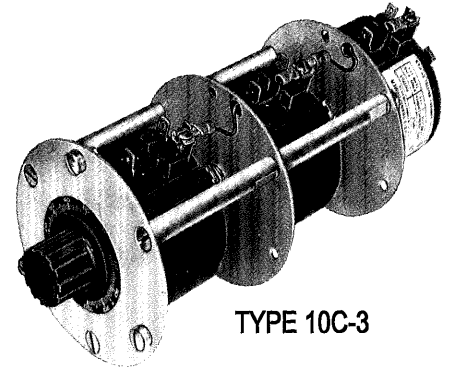

TYPE 10C-3

POWERSTAT Variable Transformers of the 10C-12C Series are offered in single and three phase manually operated assemblies. The 10C Series units operate from 120 volt lines and the 12C Series units operate from 240 volt lines. 10C Series units are rated at 2.25 amperes for constant current loads and 3.0 amperes for constant impedance loads. When line voltage connected, 12C Series units are rated at 0.7 ampere for constant current loads and 0.9 ampere for constant impedance loads. For over voltage connection the output rating for constant current loads is 0.5 ampere in the output range above line voltage but 0.7 ampere in the range from zero to line voltage. All these ratings are for metal panel mounting.

The tapping arrangement permits an output voltage of zero to line voltage or 10 percent above line voltage. Compensation may be made for a 10 percent drop in line voltage or to provide a wider working range. For

additional flexibility, units of the 10C-12C Series can be connected to deliver an increasing output voltage of zero to line voltage with either clockwise or counterclockwise knob rotation. As shown in Figure A, all models can be operated at any frequency between 50 and 2000 hertz without reduction in allowable output current. Figure B shows the regulation curves for POWERSTAT Variable Transformers of the 10C-12C Series operating at full rated load. The curves show the voltage drop at any brush setting when full load is applied. For less than full load, voltage drop is proportional to the load. Driving torque, d-c resistance per coil and maximum core and brush loss when operating under no load are given in the chart. All types are of open construction designed for back-of-panel mounting. Type 10C and type 12C have 1/16 inch (1.6mm) high non-turn devices for keying the units to the panels. All units have a 2 inch (50.8mm) dial graduated 0-100 and an angle of knob rotation of 322°.

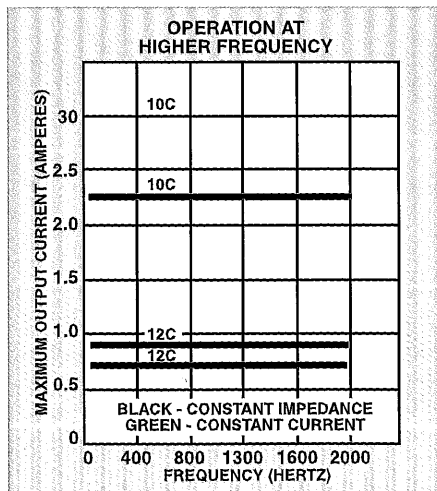

FIGURE A

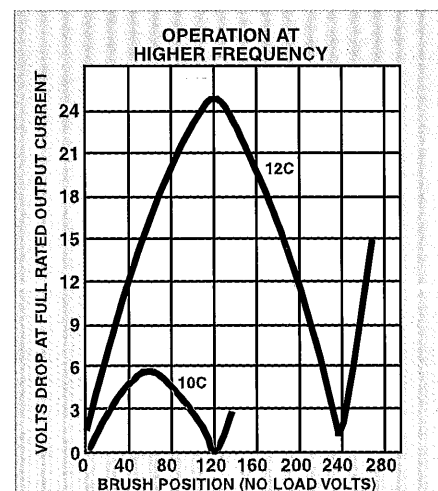
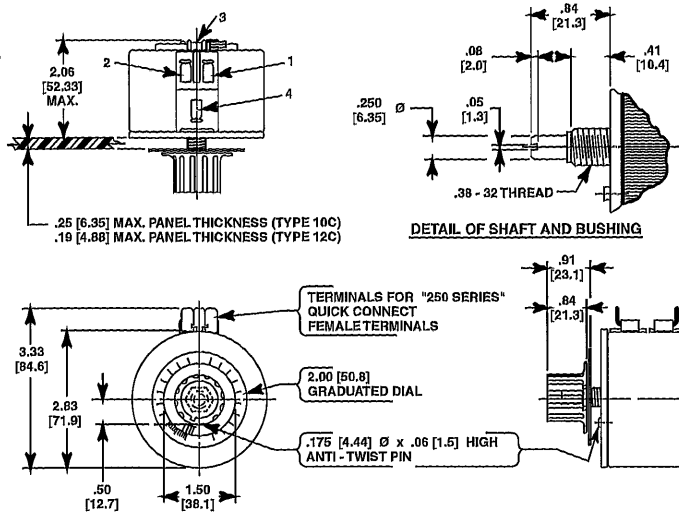
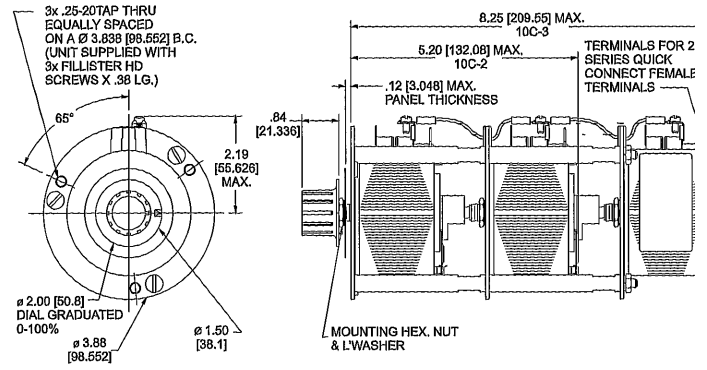

FIGURE B

10C - 12C series



TYPE 10C



TYPES 10C-2 AND 10C-3

CONNECTIONS AND RATINGS

TYPE	CONNECTION	INPUT		OUTPUT				KNOB ROTATION	TERMINALS			
		VOLTS	HERTZ	CONSTANT CURRENT LOAD		CONSTANT IMPEDANCE LOAD			INPUT	JUMPER†	OUTPUT	
				MAX. AMPS	MAX. KVA	MAX. AMPS	MAX. KVA					
10C	#1	120	50/60	0-120	2.25†	0.27	3†	0.36	CW	1-2	—	1-3
			60	0-132	2.25†	0.30	—	—	CW	1-2	—	2-3
12C	#1	240	50/60	0-240	0.7†	0.17	0.9†	0.22	CW	1-2	—	1-3
												2-3
												1-3
10C-2	#2 1-Phase Series	240	50/60	0-240	2.25†	0.54	3†	0.72	CW	1-2	—	1-3
												2-3
	#2 3-Phase Series	120	50/60	0-120	2.25†	0.47	3†	0.62	CW	1-1	1-1	3-3
												3-3
		60	0-264	2.25†	0.59	—	—	CW	4-4	1-1	3-3	
												3-3
12C-2	#2 1-Phase Series	480	50/60	0-480	0.7†	0.29	0.9†	0.37	CW	2-2	1-1	3-3
												3-3
	#2 3-Phase Open Data	240	50/60	0-240	0.7†	0.29	0.9†	0.37	CW	1-1	2-2	3-3
												3-3
10C-3	#3 3-Phase Wye	240	60	0-240	2.25†	0.94	3†	1.2	CW	2-2-2	1-1-1	3-3-3
												3-3-3
												3-3-3
12C-3	#3 3-Phase Wye	480	50/60	0-480	0.7†	0.58	0.9†	0.75	CW	2-2-2	1-1-1	3-3-3
												3-3-3

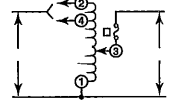

CONNECTION 1

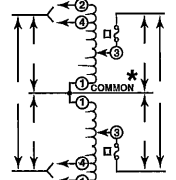

CONNECTION 2

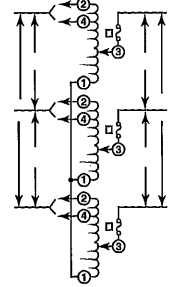

CONNECTION 3

* Common used as third leg in 3-phase open data or neutral in 3-wire single phase series and 4-wire 3-phase wye connections; not used in 2-wire series or 3-wire wye connections.

† Rating when mounted on a metal panel. When mounted on a bracket or a nonmetallic panel, derate to 2.5 amperes for 10C series. 0.75 amperes for 12C series.

‡ Rating when mounted on a metal panel. When mounted on a bracket or a nonmetallic panel, derate to 1.75 amperes for 10C series, 0.5 amperes for 12C series.

§ Maximum current when mounted on a metal panel is 0.76 amperes in output voltage range from 0 to line voltage

¶ Jumper provided in standard common position should be moved or removed as required.

CONNECTIONS SHOWN ARE FOR CW KNOB ROTATION

10C - 12C series

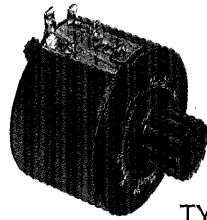

TYPE 12C

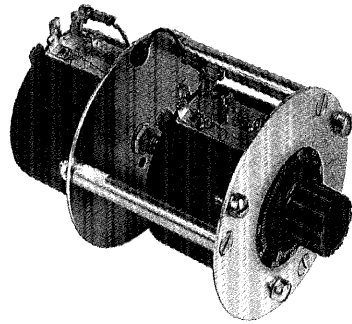

TYPE 12C-2

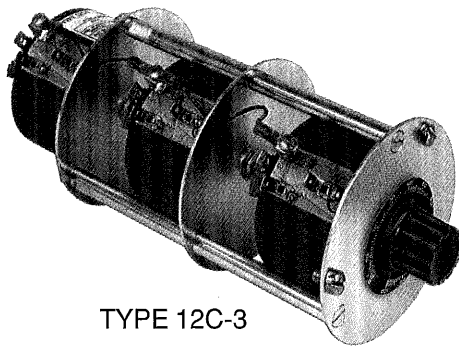

TYPE 12C-3

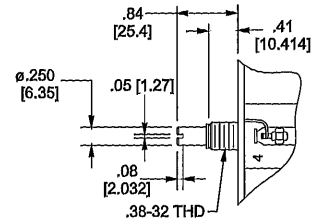

DETAIL OF SHAFT AND BUSHING

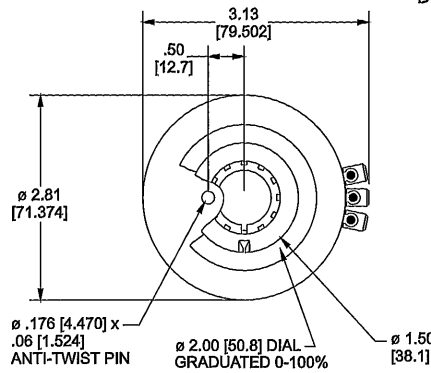

TYPE 12C

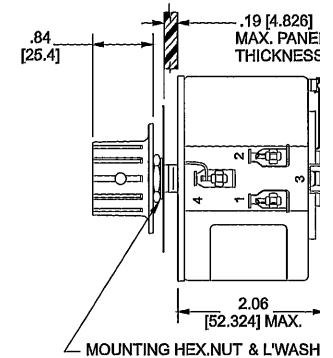

MOUNTING HEX.NUT & L'WASH

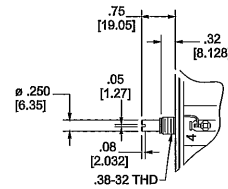

DETAIL OF SHAFT & BUSHING

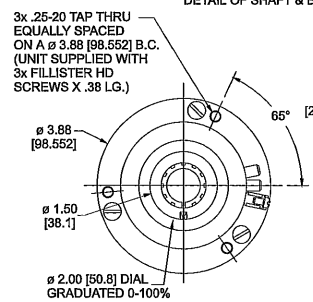

3x .25-20 TAP THRU EQUALLY SPACED ON A ø 3.88 [98.552] B.C. (UNIT SUPPLIED WITH 3x FILLISTER HD SCREWS X .38 L.G.)

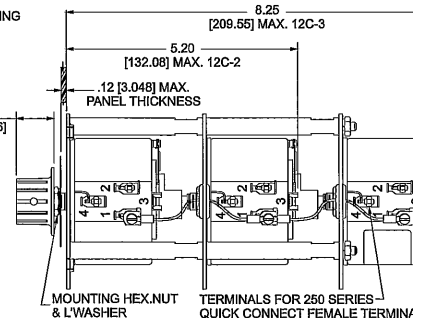

TYPES 12C-2, 12C-3

TYPE	Approximate Driving Torque		No-Load Loss at 60 Hertz (Watts)	D-C Resistance per Coil* (Ohms)
	Oz.-In.	KpCm		
10C	5	.4	1.8	14.2
10C-2	15-20	1.1 - 1.4	3.6	14.2
10C-3	20-30	1.4 - 2.2	5.4	14.2
12C	5	.4	2.0	162
12C-2	15-20	1.1 - 1.4	4.0	162
12C-3	20-30	1.4 - 2.2	6.0	162

*Measured from start to end of winding.

POTENTIOMETER ADAPTER KITS

Adapter Kits are available to permit user mounting of potentiometers, rheostats, tap switches and other devices to operate in unison with a 10C-12C Series POWERSTAT Variable Transformer. Order Kit type B211060-1 for 10C Series units or Kit type 30111-000 for 12-C Series units. The kits will accommodate devices having a 3/8"-32 mounting bushing and a 1/4" (6.4mm) diameter shaft. If desired, POWERSTAT Variable Transformers having the device factory mounted are available on special order.

