

GENERATION 4 DIGITAL I/O FAMILY DATA BOOK

Form 727-070719—July 2007

OPTO 22

43044 Business Park Drive • Temecula • CA 92590-3614
Phone: 800-321-OPTO (6786) or 951-695-3000
Fax: 800-832-OPTO (6786) or 951-695-2712
www.opto22.com

Product Support Services

800-TEK-OPTO (835-6786) or 951-695-3080
Fax: 951-695-3017
Email: support@opto22.com
Web: support.opto22.com

G4 Digital I/O Family Data Book
Form 727-070719—July 2007

Copyright © 2003–2007 Opto 22.
All rights reserved.

Printed in the United States of America.

The information in this manual has been checked carefully and is believed to be accurate; however, Opto 22 assumes no responsibility for possible inaccuracies or omissions. Specifications are subject to change without notice.

Opto 22 warrants all of its products to be free from defects in material or workmanship for 30 months from the manufacturing date code. This warranty is limited to the original cost of the unit only and does not cover installation, labor, or any other contingent costs. Opto 22 I/O modules and solid-state relays with date codes of 1/96 or later are guaranteed for life. This lifetime warranty excludes reed relay, SNAP serial communication modules, SNAP PID modules, and modules that contain mechanical contacts or switches. Opto 22 does not warrant any product, components, or parts not manufactured by Opto 22; for these items, the warranty from the original manufacturer applies. These products include, but are not limited to, OptoTerminal-G70, OptoTerminal-G75, and Sony Ericsson GT-48; see the product data sheet for specific warranty information. Refer to Opto 22 form number 1042 for complete warranty information.

Cyrano, Opto 22 FactoryFloor, Optomux, and Pamux are registered trademarks of Opto 22. Generation 4, ioControl, ioDisplay, ioManager, ioProject, ioUtilities, *mistic*, Nvio, Nvio.net Web Portal, OptoConnect, OptoControl, OptoDataLink, OptoDisplay, OptoOPCServer, OptoScript, OptoServer, OptoTerminal, OptoUtilities, PAC Control, PAC Display, PAC Manager, PAC Project, SNAP Ethernet I/O, SNAP I/O, SNAP OEM I/O, SNAP PAC System, SNAP Simple I/O, SNAP Ultimate I/O, and SNAP Wireless LAN I/O are trademarks of Opto 22.

ActiveX, JScript, Microsoft, MS-DOS, VBScript, Visual Basic, Visual C++, and Windows are either registered trademarks or trademarks of Microsoft Corporation in the United States and other countries. Linux is a registered trademark of Linus Torvalds. Unicenter is a registered trademark of Computer Associates International, Inc. ARCNET is a registered trademark of Datapoint Corporation. Modbus is a registered trademark of Schneider Electric. Wiegand is a registered trademark of Sensor Engineering Corporation. Nokia, Nokia M2M Platform, Nokia M2M Gateway Software, and Nokia 31 GSM Connectivity Terminal are trademarks or registered trademarks of Nokia Corporation. Sony is a trademark of Sony Corporation. Ericsson is a trademark of Telefonaktiebolaget LM Ericsson.

All other brand or product names are trademarks or registered trademarks of their respective companies or organizations.

Table of Contents

Chapter 1: Welcome to the G4 Digital I/O Family Data Book	1
Introduction	1
What's In This Book	1
For Help	2
Chapter 2: Generation 4 Digital I/O Mounting Racks	3
Overview of Mounting Racks	3
Features	3
Choose Your Rack	4
G4PB4 Mounting Rack	5
Description	5
Specifications	5
Dimensions	5
Connections	5
G4PB4R Mounting Rack	6
Description	6
Specifications	6
Dimensions	6
Connections	6
G4PB8 Mounting Rack	7
Description	7
Specifications	7
Dimensions	7
Connections—G4PB8	8
G4PB8H Mounting Rack	8
Description	8
Specifications	9

Dimensions—G4PB8H	9
Connections—G4PB8H	9
G4PB16 Mounting Rack	10
Description	10
Specifications	10
Dimensions—G4PB16	11
Connections—G4PB16	11
G4PB16H Mounting Rack	12
Description	12
Specifications	12
Dimensions—G4PB16H	13
Connections—G4PB16H	13
G4PB16HC Mounting Rack	14
Description	14
Specifications	14
Dimensions—G4PB16HC	15
Connections—G4PB16HC	15
G4PB16I Mounting Rack	16
Description	16
Specifications	16
Dimensions—G4PB16I	17
Connections—G4PB16I	17
Application Examples—G4PB16I	18
Positive-True Logic	
Connection to PLC	18
Negative-True Logic	
Connection to PLC	18
G4PB16T Mounting Rack	19
Description	19
Specifications	19
Dimensions	19
Connections—G4PB16T	20
G4PB24 Mounting Rack	20
Description	20
Specifications	21
Dimensions	21
Connections—G4PB24	22

G4PB32DEC Mounting Rack	23
Description	23
Specifications	23
Dimensions	24
Connections—G4PB32DEC	25
Chapter 3: Generation 4 Racks with Integral Digital I/O	27
Overview of Racks with Integral I/O	27
Features	27
Choose Your Rack	27
G4PB16J and K Racks with Integral Inputs.....	28
Description	28
Specifications	28
Dimensions—G4PB16J and K	29
Connections—G4PB16J and K	29
G4PB16L Rack with Integral Outputs	30
Description	30
Specifications and Dimensions	30
Connections—G4PB16L.....	31
Chapter 4: Generation 4 Digital I/O Modules	33
Overview of All Modules	33
Features	33
Choose Your Module	33
Digital DC Input Modules	35
Description	35
Specifications—DC Input Modules	35
Specifications—DC Input Modules (continued)	36
Dimensions—DC Input Modules	36
Schematics—DC Input Modules	37
Digital AC Input Modules	38
Description	38
Specifications—AC Input Modules	38
Specifications—AC Input Modules (continued)	39
Dimensions—AC Input Modules	39
Schematics—AC Input Modules	40

Digital Input Test Module	40
Description	40
Specifications—Digital Input Test Module	40
Dimensions and Schematics—Digital Input Test Module	41
Digital DC Output Modules	41
Description	41
Specifications—DC Output Modules	42
Dimensions—DC Output Modules	43
Schematics—DC Output Modules	43
Digital AC Output Modules	44
Description	44
Specifications—AC Output Modules	44
Specifications—AC Output Modules (continued)	45
Dimensions—AC Output Modules	46
Schematics—AC Output Modules	47
Dry Contact Output Modules	47
Description	47
Specifications—Dry Contact Output Modules	48
Specifications—Dry Contact Output Modules (continued)	48
Dimensions and Schematics—Dry Contact Output Modules	49
Digital Output Test Module	50
Description	50
Specifications—Output Test Module	50
Dimensions and Schematics—Output Test Module	50

Chapter 5: Generation 4 Digital I/O Accessories 51

Overview of Accessories	51
PC to I/O Mounting Rack Adapter Card (G4AC5)	51
Description	51
Requirements	51
Rack Part Numbers for the G4AC5 Adapter Card	52
Fully Compatible Racks	52
Racks That Can Be Modified	52
Incompatible Racks	52
Cables and Connectors	53
Description	53
Specifications	53

Building Your Own Cables	53
Fuses	54
Description	54
Ordering Guide	54
Jumper Strap	54
Description	54
Dimensions	54
Appendix A: Designing Custom I/O Mounting Racks	55
Introduction	55
Dimensions	55
Printed Circuit Patterns	56
Parts List	56
Appendix B: Wiring Diagrams	57
Input Modules Using DC Field Voltages	57
Input Modules Using AC Field Voltages	58
Output Modules Using DC Field Voltages	59
Output Modules Using AC Field Voltages	60

Welcome to the G4 Digital I/O Family Data Book

OPTO 22

Introduction

Generation 4 digital I/O, introduced by Opto 22 in 1989, provides increased density over older modules, while maintaining single-channel flexibility. LEDs and fuses are generally on the modules rather than the rack to make them visible and easy to service. The G4 digital I/O family includes a wide variety of modules, mounting racks, and accessories to meet the needs of your system.

What's In This Book

The *G4 Digital I/O Family Data Book* pulls together information on all Generation 4 digital I/O family products. This same information can also be found in individual product data sheets; it is brought together here for your convenience.

This book covers the following:

Chapter 2, "Generation 4 Digital I/O Mounting Racks"—Choose your mounting rack from the table on [page 4](#), then see detailed drawings and specifications on the following pages.

Chapter 3, "Generation 4 Racks with Integral Digital I/O"—Detailed drawings and specifications for a special group of rack products with I/O circuitry permanently integrated.

Chapter 4, "Generation 4 Digital I/O Modules"—See the table on [page 33](#) for an overview of all G4 modules. Detailed drawings and specifications follow.

Chapter 5, "Generation 4 Digital I/O Accessories"—Find details on G4 accessories, including an adapter card, cables and connectors, fuses, and a jumper strap.

Appendix A, "Designing Custom I/O Mounting Racks"—Includes helpful information for customers who are designing their own mounting systems for Generation 4 digital I/O modules.

Appendix B, "Wiring Diagrams"—Examples for mapping field wiring to mounting racks for each type of module that can be plugged into the rack.

For Help

If you have any questions about Generation 4 Digital I/O products, please contact Opto 22. Phone hours are Monday through Friday, 8 a.m. to 5 p.m. Pacific Time.

Phone: 800-TEK-OPTO (835-6786)
951-695-3080
(Hours are Monday through Friday,
7 a.m. to 5 p.m. Pacific Time)

Fax: 951-695-3017

Email: support@opto22.com

Opto 22 website: www.opto22.com

NOTE: Email messages and phone calls to Opto 22 Product Support are grouped together and answered in the order received.

When calling for technical support, be prepared to provide a complete description of your hardware and operating system to the Product Support engineer. This information should include:

- accessories installed
- type of power supply
- types of I/O modules and racks used
- third-party devices installed
- how the system is wired.

Generation 4 Digital I/O Mounting Racks

Overview of Mounting Racks

This chapter includes information on mounting racks used with G4 digital I/O modules. For integral racks, which have permanent I/O circuitry built into the rack, see [page 27](#).

Features

The following features apply to all mounting racks in this chapter:

- Minimum mounting space required
- Spare module fuse included
- UL recognized, CSA certified, and CE compliant
- Uses a single 5, 15, or 24 VDC power supply for control power
- You can insert and remove modules easily and quickly without disturbing field wiring.
- Modules are securely attached with a threaded captive hold-down screw.
- Operating temperature: 0° to 70° C
- Humidity: 95% relative humidity, non-condensing

Choose Your Rack

Choose a rack from the following table, and then see the referenced page in this chapter for detailed drawings and specifications.

Model	Number of Channels	Input Modules	Output Modules	AC	DC	Built-in Fuse Tester	Field Connector	Control Connector	Special Features	See
G4PB4	4	●	●	●	●	●	screw-type barrier strip	screw-type barrier strip	Good for compact locations where only a few I/O points are needed.	page 5
G4PB4R	4		●	●	●		screw-type barrier strip	screw-type barrier strip	Channel-to-channel isolation between all field and control circuits. Outputs can be wired for either positive-true logic or standard negative-true logic. Cannot use dry contact output modules.	page 6
G4PB8	8	●	●	●	●	●	screw-type barrier strip	50-pin header connector	G4AC5 compatible (See page 52.)	page 7
G4PB8H	8	●	●	●	●	●	screw-type barrier strip	50-pin header connector	For use with Optomux B1, Pamux B5, and mistic B100 brain boards. Works with Opto 22 PBSA/B/C power supply. Power indicator light.	page 8
G4PB16	16	●	●	●	●	●	screw-type barrier strip	50-pin header connector	G4AC5 compatible (See page 52.)	page 10
G4PB16H	16	●	●	●	●	●	screw-type barrier strip	50-pin header connector	For use with Optomux B1, Pamux B5, and mistic B100 brain boards. Works with Opto 22 PBSA/B/C power supply. Power indicator light.	page 12
G4PB16HC	16	●	●	●	●	●	screw-type barrier strip	50-pin header connector	Extra row of terminals for field loop power connections. For use with Optomux B1, Pamux B5, and Mistic B100 brain boards. Works with Opto 22 PBSA/B/C power supply. Power indicator light.	page 14
G4PB16I	16	●	●	●	●		screw-type barrier strip	screw-type barrier strip	Channel-to-channel isolation between all field and control circuits. Outputs can be wired for either positive-true logic or standard negative-true logic; inputs can be wired for negative-true.	page 16
G4PB16T	16	●	●	●	●	●	screw-type barrier strip	screw-type barrier strip	--	page 19
G4PB24	24	●	●	●	●	●	screw-type barrier strip	50-pin header connector	G4AC5 compatible (See page 52.)	page 20
G4PB32DEC	32	●	●	●	●	●	screw-type barrier strip	50-pin header connector	Interfaces to a DEC computer DRV-11J parallel card.	page 23

G4PB4 Mounting Rack

Description

The G4PB4 I/O mounting rack compactly accommodates up to four G4 digital I/O modules in applications where only a few I/O points are needed. Insert and remove modules easily and quickly without disturbing field wiring. Modules are secured to the mounting rack with a threaded captive hold-down screw.

Barrier strips with screw terminals provide the field, control, and mounting rack power connections.

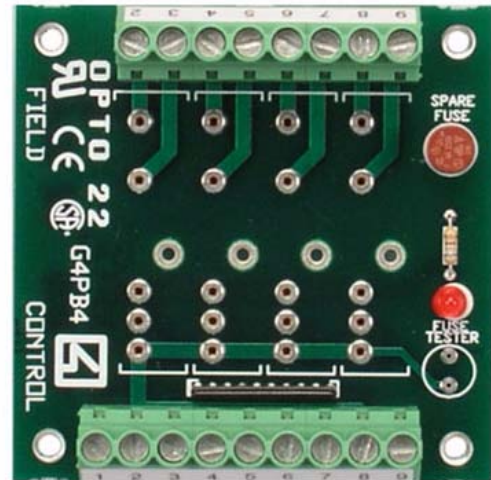

Specifications

Operating temperature	0° to 70° C
Interface connector (field and control)	Screw-type barrier strip accommodates up to 10 AWG wire

Dimensions

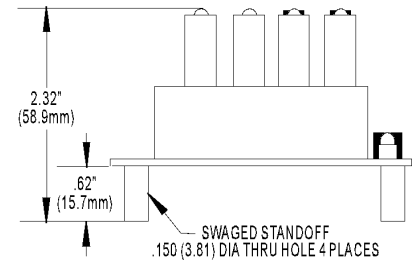
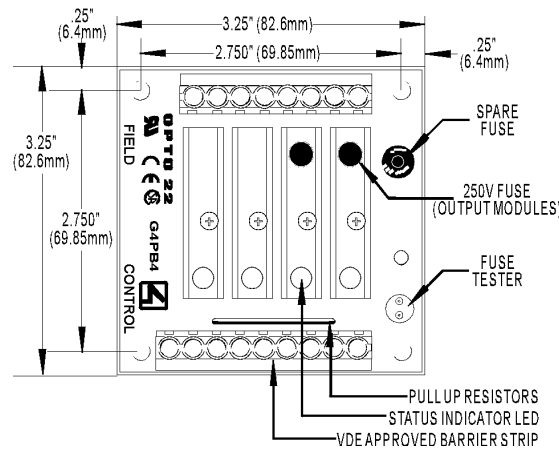

Connections

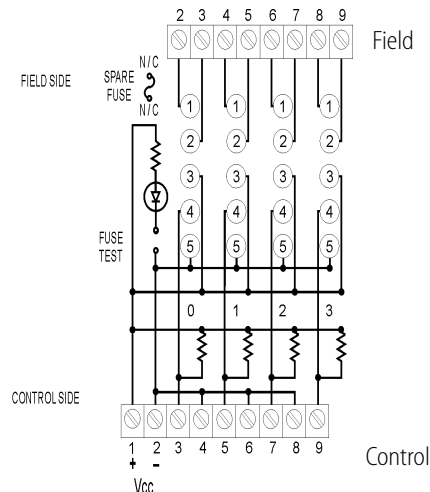

Notes:

1. Even pins on control side are connected by etch to common.
2. +VCC and return are connected to control terminals 1 and 2.

G4PB4R Mounting Rack

Description

The G4PB4R output mounting rack compactly accommodates up to four G4 output modules and features channel-to-channel isolation between all field and control circuits. Positive-true and standard negative-true control signals from computer I/O ports may be connected to the racks.

Modules are inserted and removed easily and quickly without disturbing the field wiring. The threaded captive hold-down screw on each module securely attaches them to the rack. Barrier strips with screw terminals provide the field, control, and mounting rack power connections.

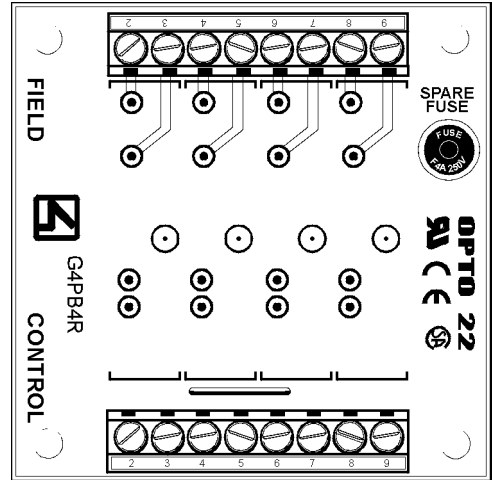

Specifications

Operating temperature	0° to 70° C
Interface connector (field and control)	Screw-type barrier strip accommodates up to 10 AWG wire

Dimensions

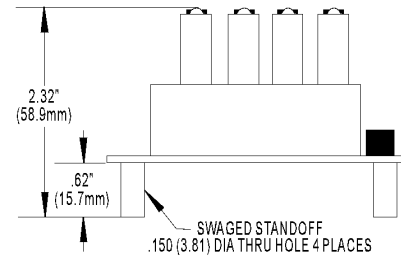
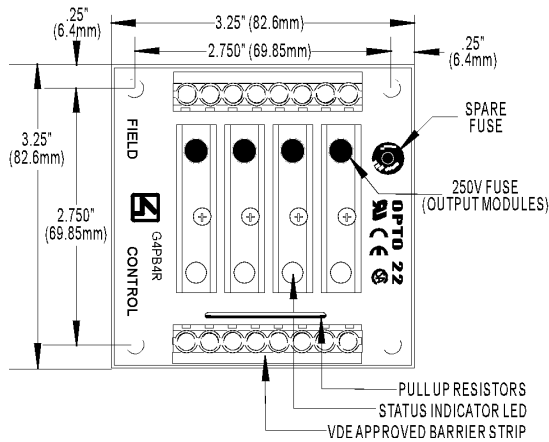

Connections

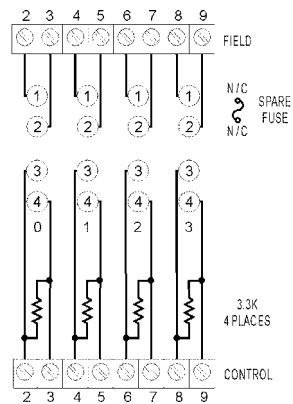

NOTE: G40DC5R, G40DC5R5, G40ACSAMA, G40ACSMA, G40DC5MA WILL NOT PLUG INTO THIS RACK.

G4PB8 Mounting Rack

Description

The G4PB8 I/O mounting rack accommodates up to eight G4 I/O modules. Insert and remove modules easily and quickly without disturbing field wiring. Modules are secured to the mounting rack with a threaded captive hold-down screw.

Barrier strips with screw terminals provide the field and mounting rack power connections. A header connector accepts a standard 50-pin cable for the logic connections (See [page 51](#) for information about the G4AC5.)

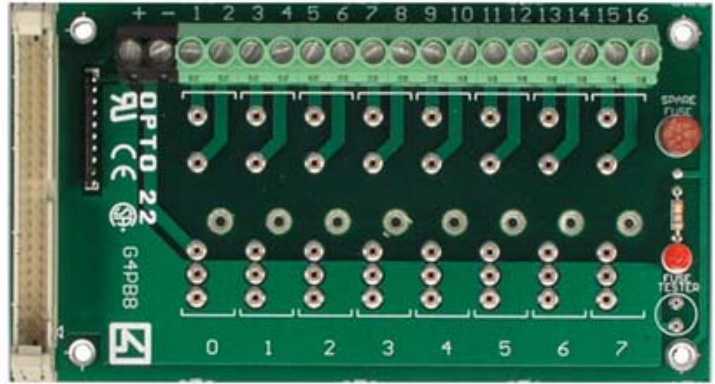

Specifications

Operating temperature	0° to 70° C
Interface connectors	
Field:	Screw-type barrier strip accommodates up to 10 AWG wire
Control:	50-pin header connector

Dimensions

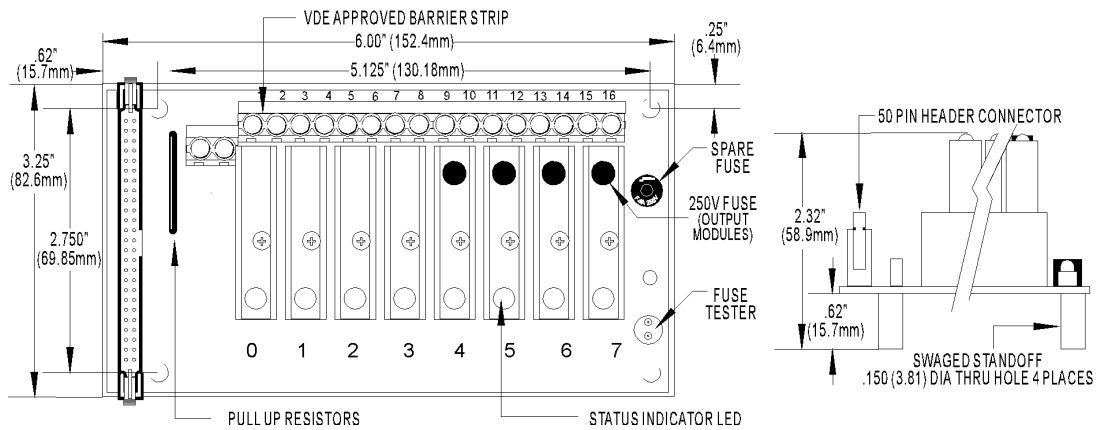

See the following page for connection information.

Connections—G4PB8

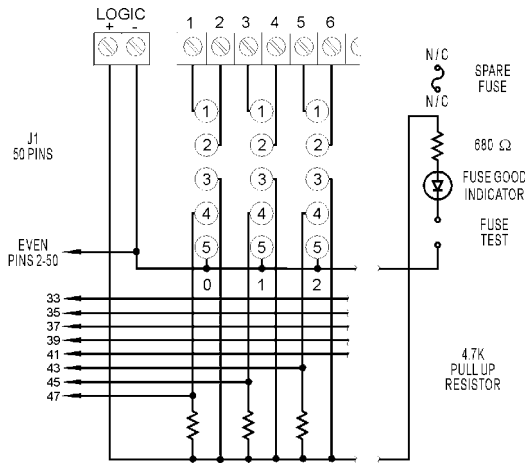

Notes:

1. Even pins on control connector are connected by etch to common.
2. +VCC and return connected to terminals marked LOGIC + and -.
3. At each module position on the field terminal strip, the lower number is always connected to pin 1 of the

Module Position	Control (Header Connector)	Field (Terminal Strip)
0	47	1 and 2
1	45	3 and 4
2	43	5 and 6
3	41	7 and 8
4	39	9 and 10
5	37	11 and 12
6	35	13 and 14
7	33	15 and 16

G4PB8H Mounting Rack

Description

The G4PB8H I/O mounting rack accommodates up to eight G4 I/O modules. A header connector accepts a standard 50-pin cable, the Optomux® B1, Pamux® B5, or B100 brain board for logic connections. Barrier strips with screw terminals provide the field and mounting rack power connections.

Insert and remove modules easily and quickly without disturbing field wiring. Modules are secured to the mounting rack with a threaded captive hold-down screw. The logic supply is fused with a 1A fuse

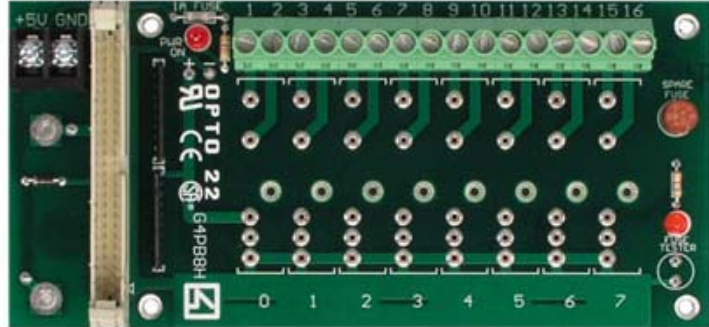

Specifications

Operating temperature	0° to 70° C
Interface connectors	
Field:	Screw-type barrier strip accommodates up to 10 AWG wire
Control:	50-pin header connector
Power:	Two-position screw terminal or Opto 22 PBSA/B/C power supply

Dimensions—G4PB8H

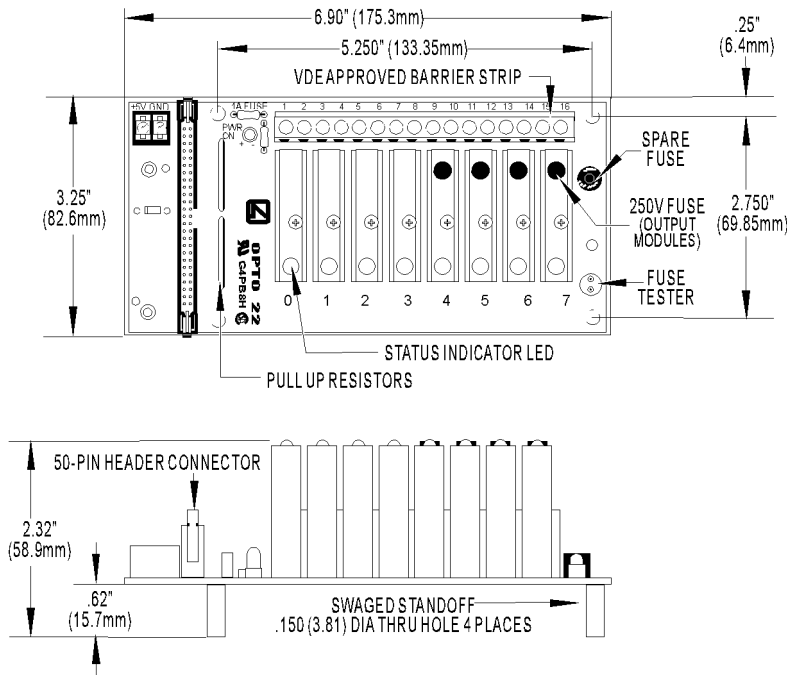

Connections—G4PB8H

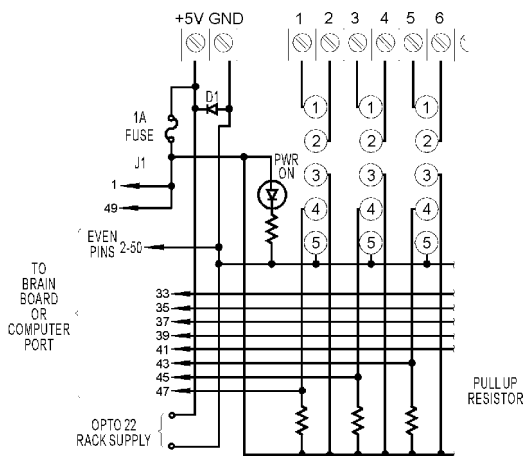

Notes:

1. Even pins on control connector are connected by etch to common.
2. +VCC and return connected to terminals marked +5V and GND.
3. At each module position on the field terminal strip, the lower number is always connected to pin 1 of the I/O module.
4. Use only 5 VDC logic modules when using the mounting rack with a brain board.

Module Position	Control (Header Connector)	Field (Terminal Strip)
0	47	1 and 2
1	45	3 and 4
2	43	5 and 6
3	41	7 and 8
4	39	9 and 10
5	37	11 and 12
6	35	13 and 14
7	33	15 and 16

G4PB16 Mounting Rack

Description

The G4PB16 I/O mounting rack accommodates up to 16 G4 I/O modules. Insert and remove modules easily and quickly without disturbing field wiring. Modules are secured to the mounting rack with a threaded captive hold-down screw.

Barrier strips with screw terminals provide the field and mounting rack power connections. A header connector accepts a standard 50-pin cable for the logic connections. (See [page 51](#) for information on the G4AC5.)

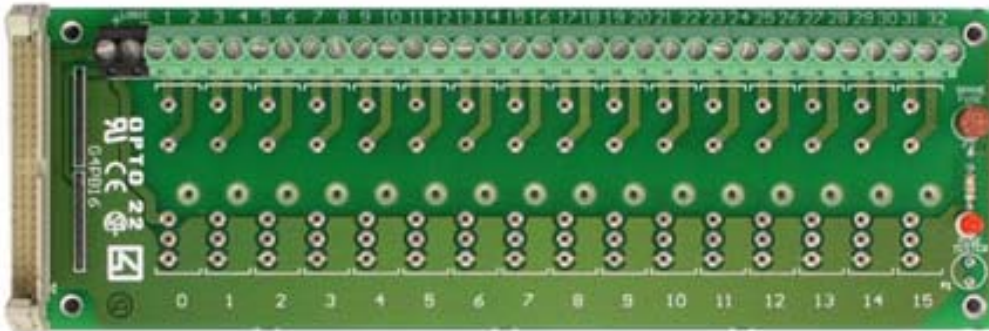

Specifications

Operating temperature	0° to 70° C
Interface connectors	
Field:	Screw-type barrier strip accommodates up to 10 AWG wire
Control:	50-pin header connector

See the following page for dimensions and connection information.

Dimensions—G4PB16

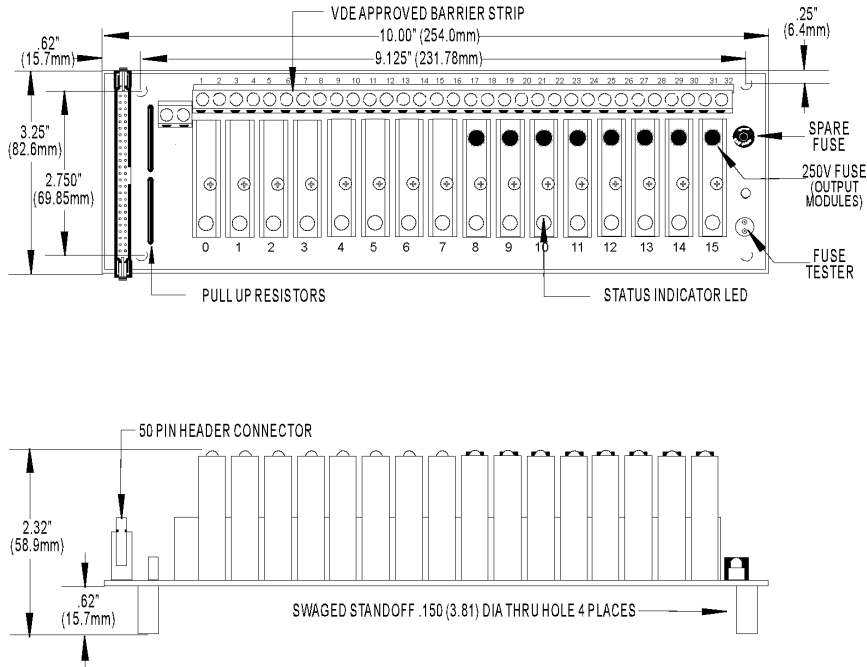

Connections—G4PB16

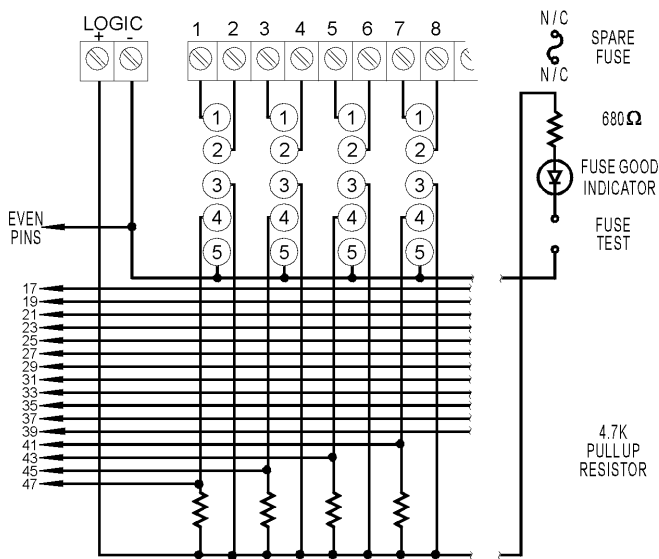

Notes:

1. Even pins on control connector are connected by etch to common.
2. +VCC and return connected to terminals marked LOGIC + and -.
3. At each module position on the field terminal strip, the lower number is always connected to pin 1 of the I/O module.

Module Position	Control (Header Connector)	Field (Terminal Strip)
0	47	1 and 2
1	45	3 and 4
2	43	5 and 6
3	41	7 and 8
4	39	9 and 10
5	37	11 and 12
6	35	13 and 14
7	33	15 and 16
8	31	17 and 18
9	29	19 and 20
10	27	21 and 22
11	25	23 and 24
12	23	25 and 26
13	21	27 and 28
14	19	29 and 30
15	17	31 and 32

G4PB16H Mounting Rack

Description

The G4PB16H I/O mounting rack accommodates up to 16 G4 I/O modules. A header connector accepts a standard 50-pin cable, the Optomux® B1, Pamux® B5, or Mystic™ B100 brain board for logic connections. Barrier strips with screw terminals provide the field and mounting rack power connections.

Insert and remove modules easily and quickly without disturbing field wiring. Modules are secured to the mounting rack with a threaded captive hold-down screw. The logic supply is fused with a 1A fuse

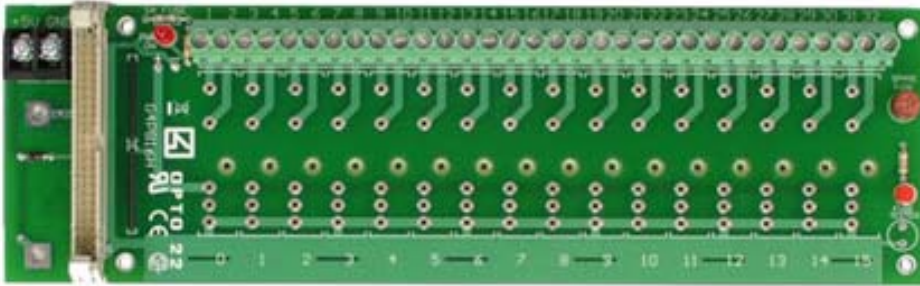

Specifications

Operating temperature	0° to 70° C
Interface connectors	
Field:	Screw-type barrier strip accommodates up to 10 AWG wire
Control:	50-pin header connector
Power:	Two-position screw terminal or Opto 22 PBSA/B/C power supply

See the following page for dimensions and connection information.

Dimensions—G4PB16H

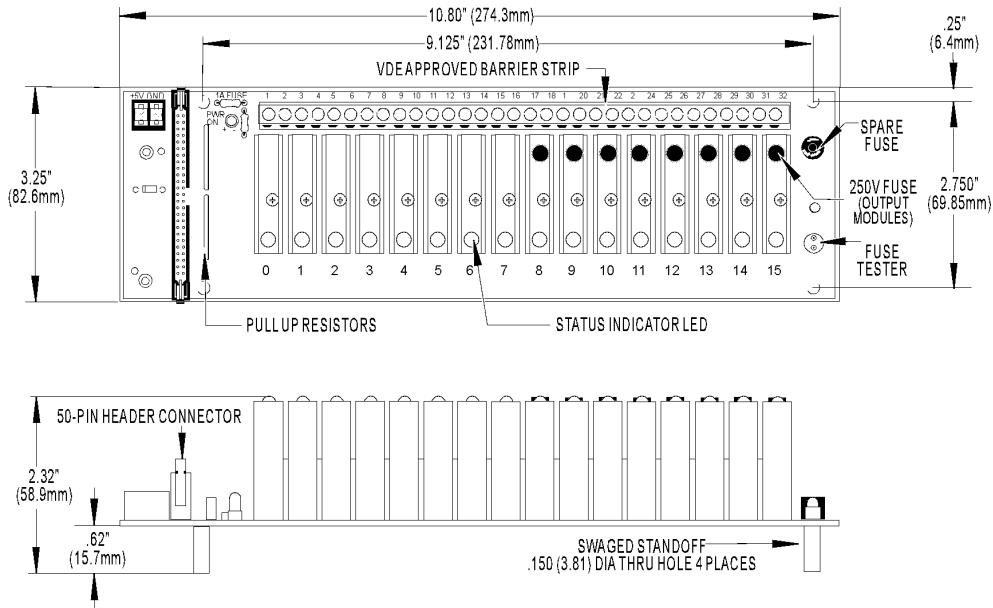

Connections—G4PB16H

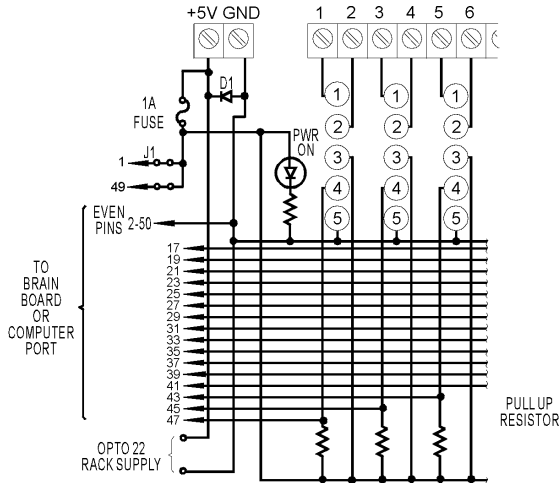

Notes:

1. Even pins on control connector are connected by etch to common.
2. +VCC and return connected to terminals marked +5V and GND.
3. At each module position on the field terminal strip, the lower number is always connected to pin 1 of the I/O module.
4. Use only 5 VDC logic modules when using the mounting rack with a brain board.

Module Position	Control (Header Connector)	Field (Terminal Strip)
0	47	1 and 2
1	45	3 and 4
2	43	5 and 6
3	41	7 and 8
4	39	9 and 10
5	37	11 and 12
6	35	13 and 14
7	33	15 and 16
8	31	17 and 18
9	29	19 and 20
10	27	21 and 22
11	25	23 and 24
12	23	25 and 26
13	21	27 and 28
14	19	29 and 30
15	17	31 and 32

G4PB16HC Mounting Rack

Description

The G4PB16HC I/O mounting rack accommodates up to 16 G4 I/O modules and features an extra row of terminals for field loop power connections. A header connector accepts a standard 50-pin cable, the Optomux® B1, Pamux® B5, or B100 brain board for logic connections. Barrier strips with screw terminals provide the field and mounting rack power connections.

Insert and remove modules easily and quickly without disturbing field wiring. Modules are secured to the mounting rack with a threaded captive hold-down screw. The logic supply is fused with a 1A fuse.

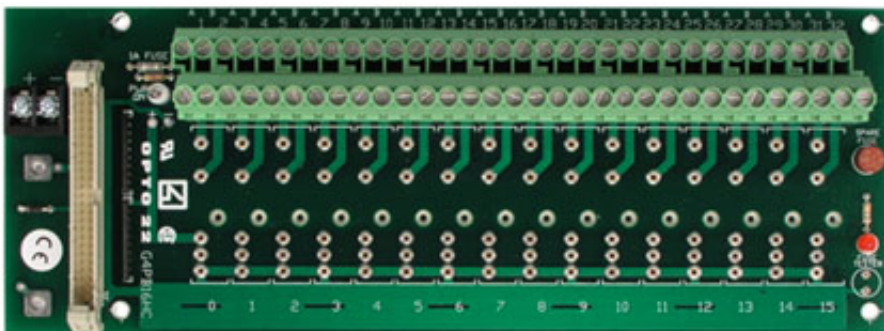

Specifications

Operating temperature	0° to 70° C
Interface connectors	
Field:	Screw-type barrier strip accommodates up to 10 AWG wire
Control:	50-pin header connector
Power:	Two-position screw terminal or Opto 22 PBSA/B/C power supply

See the following page for dimensions and connection information.

Dimensions—G4PB16HC

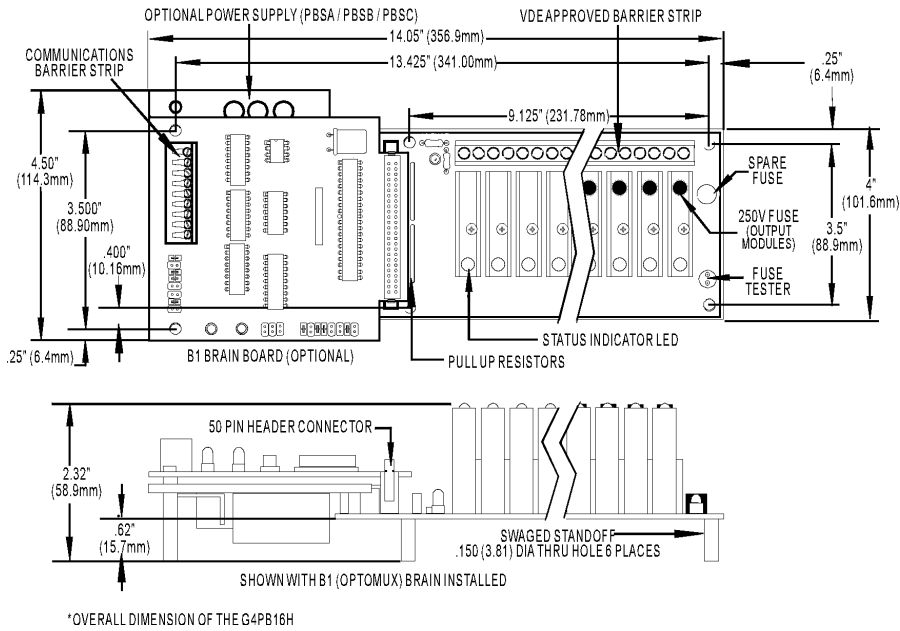

Connections—G4PB16HC

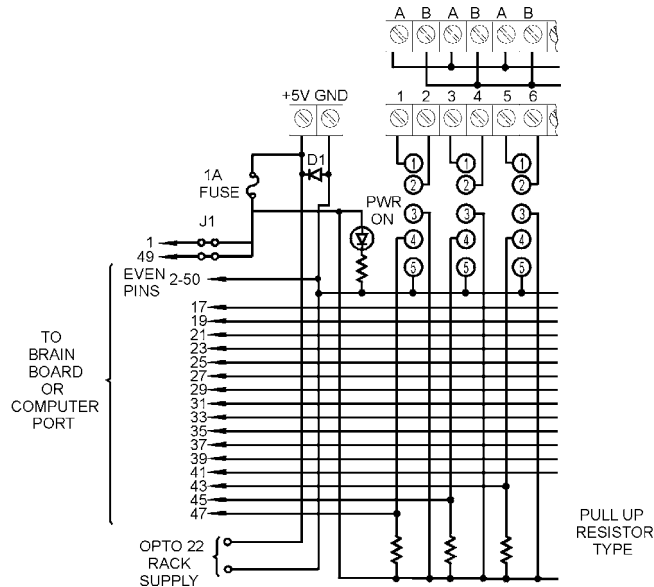

Notes:

1. Even pins on control connector are connected by etch to common.
2. +VCC and return connected to terminals marked +5V and GND.
3. At each module position on the field terminal strip, the lower number is always connected to pin 1 of the I/O module.
4. Use only 5 VDC logic modules when using the mounting rack with a brain board.

Module Position	Control (Header Connector)	Field (Terminal Strip)
0	47	1 and 2
1	45	3 and 4
2	43	5 and 6
3	41	7 and 8
4	39	9 and 10
5	37	11 and 12
6	35	13 and 14
7	33	15 and 16
8	31	17 and 18
9	29	19 and 20
10	27	21 and 22
11	25	23 and 24
12	23	25 and 26
13	21	27 and 28
14	19	29 and 30
15	17	31 and 32

G4PB16I Mounting Rack

Description

The G4PB16I I/O mounting rack accommodates up to 16 G4 I/O modules and features channel-to-channel isolation between all field and control circuits. Output modules may have their control side wired for either positive-true or standard negative-true control signals from computer I/O ports. Input modules operate only with negative true logic.

Insert and remove modules easily and quickly without disturbing field wiring. Modules are secured to the mounting rack with a captive hold-down screw. Barrier strips with screw terminals provide the field, control, and mounting rack power connections.

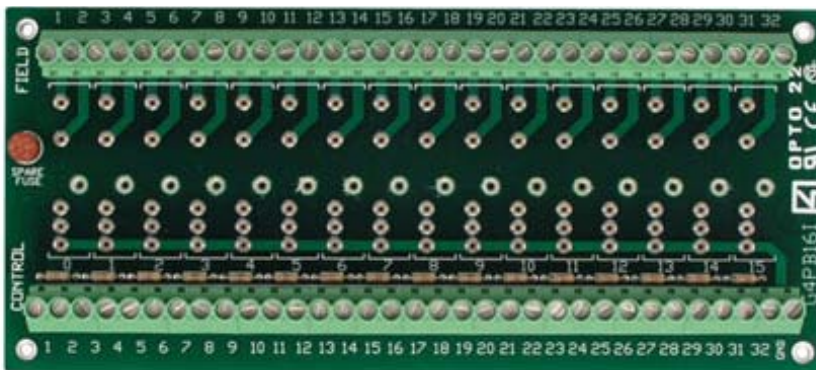

Specifications

Operating temperature	0° to 70° C
Interface connector (field and control)	Screw-type barrier strip accommodates up to 10 AWG wire

See the following page for dimensions and connection information.

Dimensions—G4PB16I

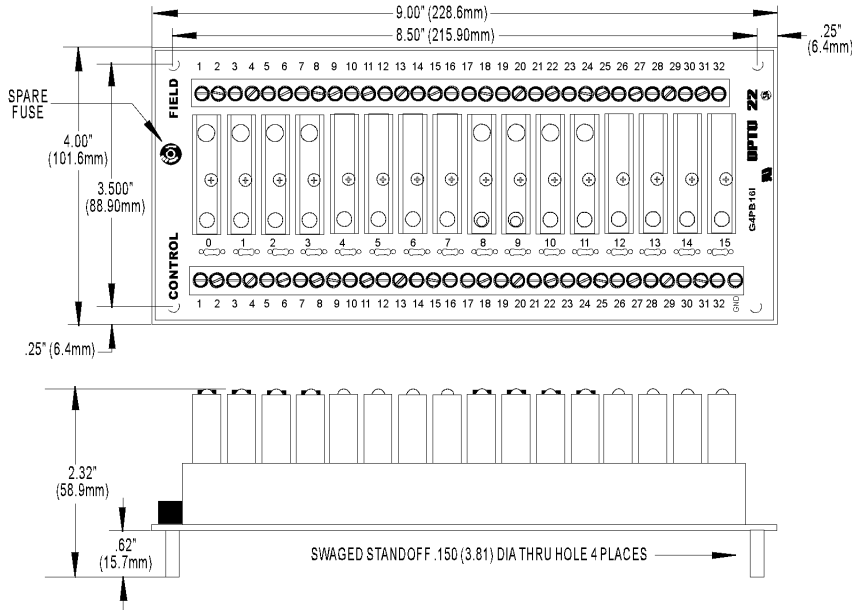

Connections—G4PB16I

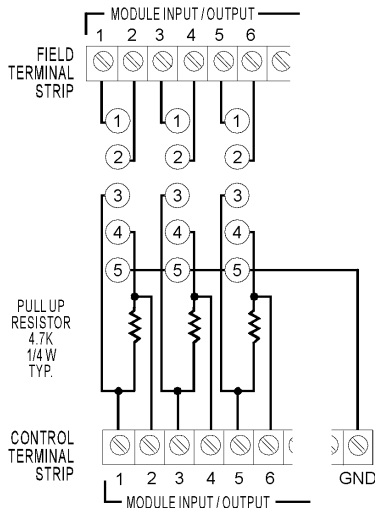

Notes:

1. At each module position on the field terminal strip, the lower number is always connected to pin 1 of the module.
2. Input modules and dry contact output modules (G4ODC5R and G4ODC5R5) require the power supply's ground to be connected to the control side's GND terminal. These modules also require that odd-numbered connections on the control side be connected to +VCC.
3. Input modules use even-numbered control terminals and can only be wired for negative-true logic.
4. To wire output modules for standard negative-true logic, connect the odd-numbered control terminals to VCC and use the even-numbered terminals for control.
5. To wire output modules for positive-true logic, connect the even-numbered control terminals to logic ground and use the odd-numbered terminals for control.

See application examples on the following page.

Module Position	Control (Header Connector)	Field (Terminal Strip)
0	47	1 and 2
1	45	3 and 4
2	43	5 and 6
3	41	7 and 8
4	39	9 and 10
5	37	11 and 12
6	35	13 and 14
7	33	15 and 16
8	31	17 and 18
9	29	19 and 20
10	27	21 and 22
11	25	23 and 24
12	23	25 and 26
13	21	27 and 28
14	19	29 and 30
15	17	31 and 32

Application Examples—G4PB16I

For wiring G4 digital output modules (except dry contact modules):

Positive-True Logic Connection to PLC

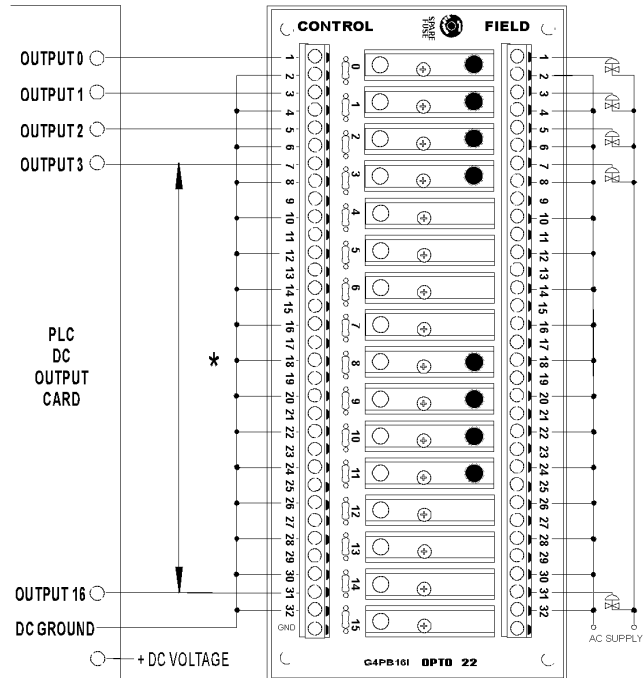

* This wiring can be done using a G4STRAP.

Negative-True Logic Connection to PLC

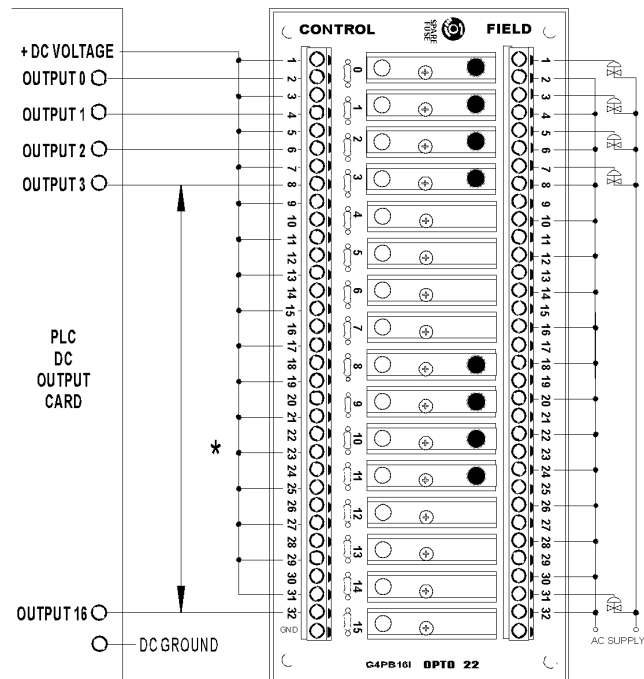

* This wiring can be done using a G4STRAP.

G4PB16T Mounting Rack

Description

The G4PB16T I/O mounting rack accommodates up to 16 G4 I/O modules. Insert and remove modules easily and quickly without disturbing field wiring. Modules are secured to the mounting rack with a threaded captive hold-down screw.

Barrier strips with screw terminals provide the field, logic, and mounting rack power connections.

Modules on the G4PB16T can be wired for standard negative true logic only. (For positive true logic on outputs, see form #460, the G4PB16I data sheet.)

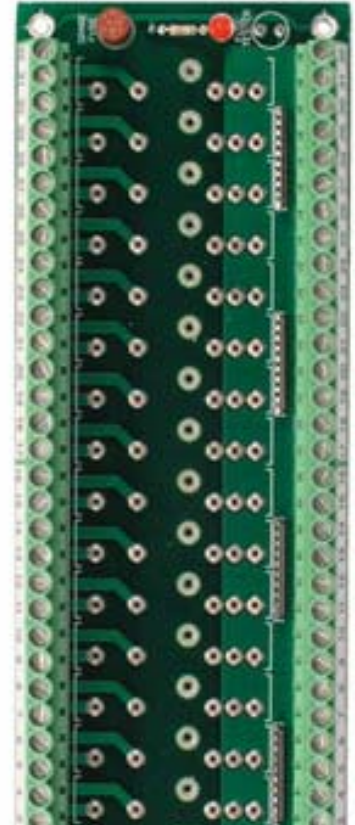

Specifications

Operating temperature	0° to 70° C
Interface connector (field and control)	Screw-type barrier strip accommodates up to 10 AWG wire

Dimensions

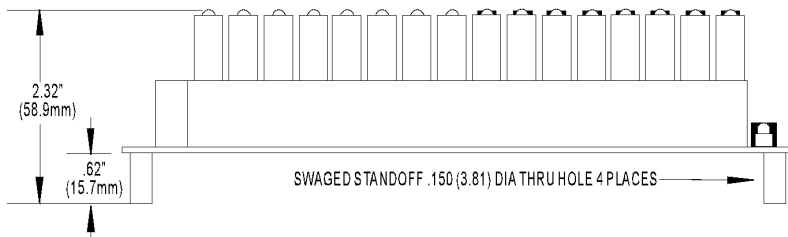
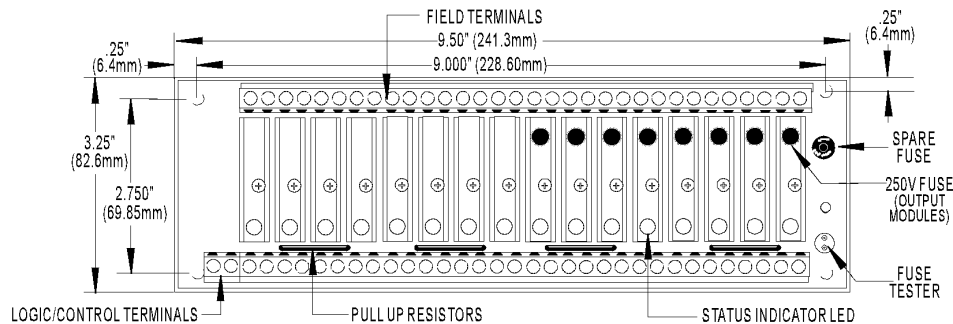

See the following page for connection information.

Connections—G4PB16T

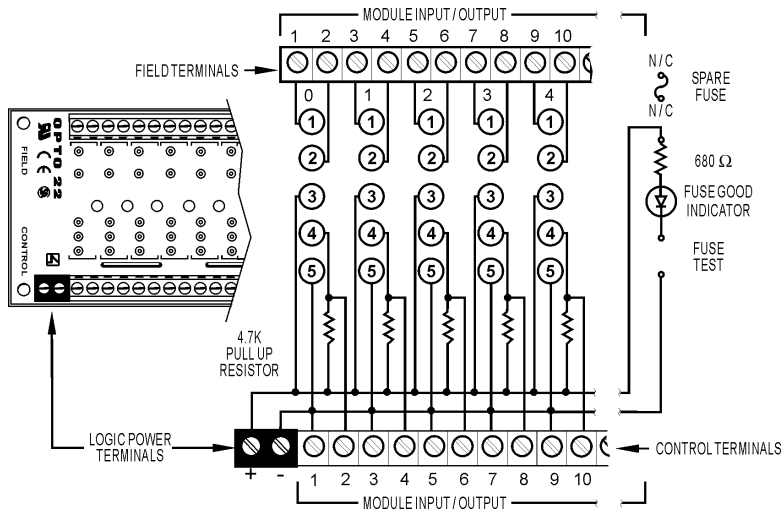

Module Position	Control (Header Connector)	Field (Terminal Strip)
0	47	1 and 2
1	45	3 and 4
2	43	5 and 6
3	41	7 and 8
4	39	9 and 10
5	37	11 and 12
6	35	13 and 14
7	33	15 and 16
8	31	17 and 18
9	29	19 and 20
10	27	21 and 22
11	25	23 and 24
12	23	25 and 26
13	21	27 and 28
14	19	29 and 30
15	17	31 and 32

Notes:

1. +VCC and return are connected to control terminals marked + and -.
2. All odd-numbered terminals on the control terminal strip are connected by etch to the VCC return terminal marked -.
3. At each module position on the field terminal strip, the lower number is always connected to pin 1 of the I/O module.

G4PB24 Mounting Rack

Description

The G4PB24 I/O mounting rack accommodates up to 24 G4 I/O modules. Insert and remove modules easily and quickly without disturbing field wiring. Modules are secured to the mounting rack with a threaded captive hold-down screw.

Barrier strips with screw terminals provide the field and mounting rack power connections. A header connector accepts a standard 50-pin cable for the logic connections. The rack works with the G4AC5 computer interface. (See [page 51](#).)

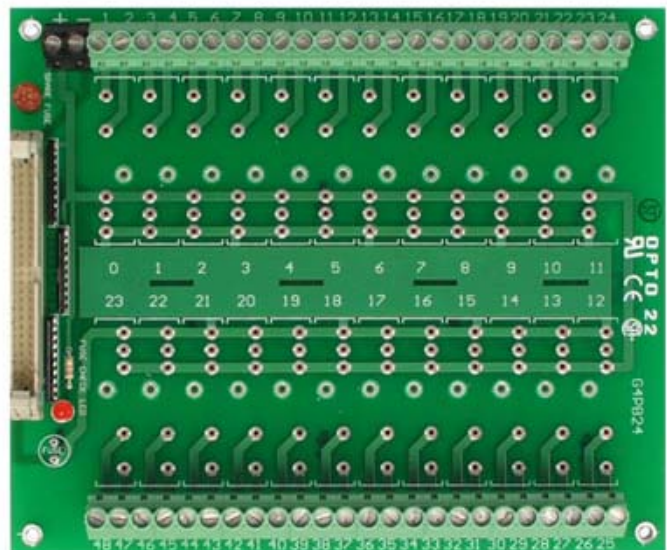

Specifications

Operating temperature	0° to 70° C
Interface connectors	
Field:	Screw-type barrier strip accepts up to 10 AWG wire
Control:	50-pin header connector

Dimensions

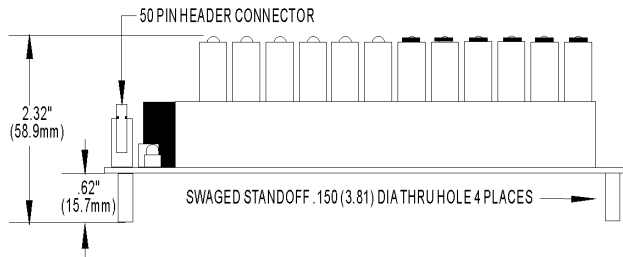
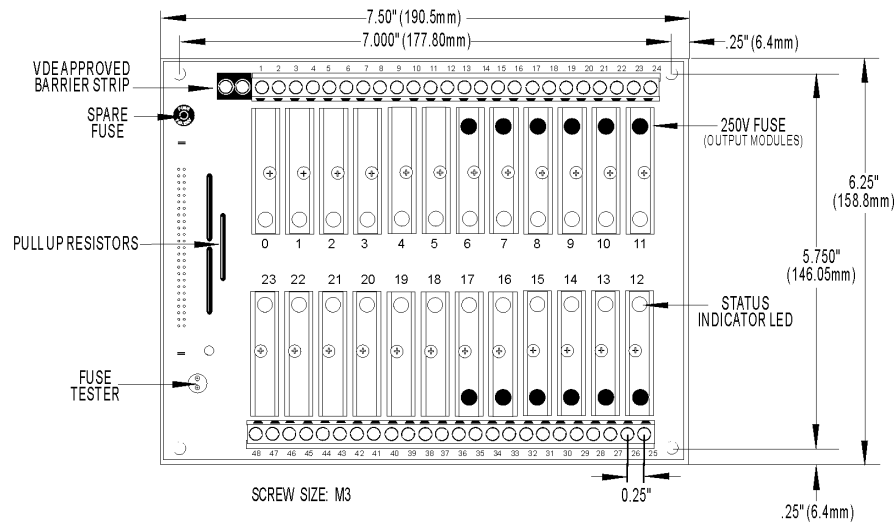

See the following page for connection information.

Connections—G4PB24

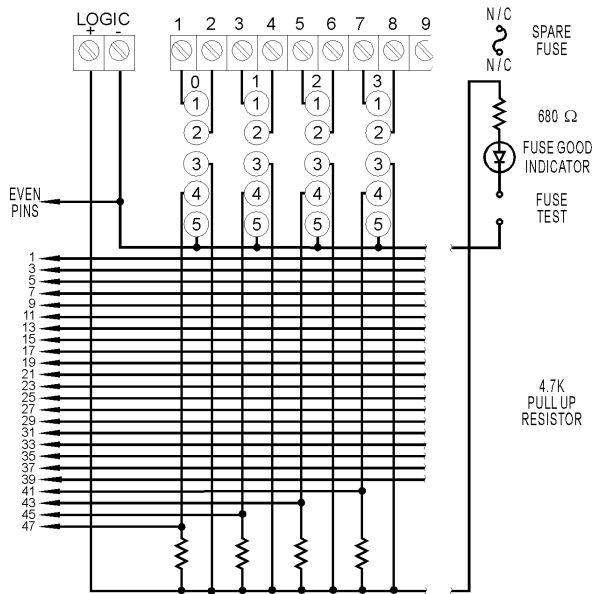

Notes:

1. Even pins on control connector are connected by etch to common.
2. +VCC and return connected to terminals marked LOGIC + and -.
3. At each module position on the field terminal strip, the lower number is always connected to pin 1 of the I/O module.

Module Position	Control (Header Connector)	Field (Terminal Strip)
0	47	1 and 2
1	45	3 and 4
2	43	5 and 6
3	41	7 and 8
4	39	9 and 10
5	37	11 and 12
6	35	13 and 14
7	33	15 and 16
8	31	17 and 18
9	29	19 and 20
10	27	21 and 22
11	25	23 and 24
12	23	25 and 26
13	21	27 and 28
14	19	29 and 30
15	17	31 and 32
16	15	33 and 34
17	13	35 and 36
18	11	37 and 38
19	9	39 and 40
20	7	41 and 42
21	5	43 and 44
22	3	45 and 46
23	1	47 and 48

G4PB32DEC Mounting Rack

Description

The G4PB32DEC I/O mounting rack accommodates up to 32 G4 digital I/O modules and is used to interface to a DEC computer DRV-11J parallel card.

A header connector on the rack is used for logic connections by using a standard 50-conductor, flat ribbon cable. Barrier strips with screw terminals provide the field and mounting rack power connections.

Insert and remove modules easily and quickly without disturbing field wiring. Modules are secured to the mounting rack with a threaded captive hold-down screw.

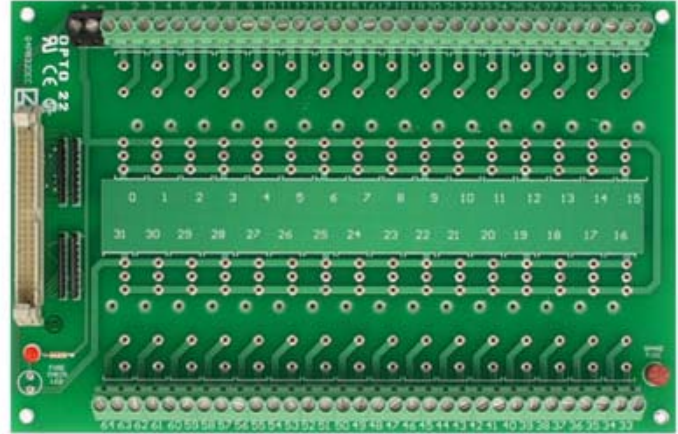

Specifications

Operating temperature	0° to 70° C
Interface connectors	
Field:	Screw-type barrier strip accommodates up to 10 AWG wire
Control:	50-pin header connector
Power:	Two-position screw terminal for a VCC power supply

See the following pages for dimensions and connection information.

Dimensions

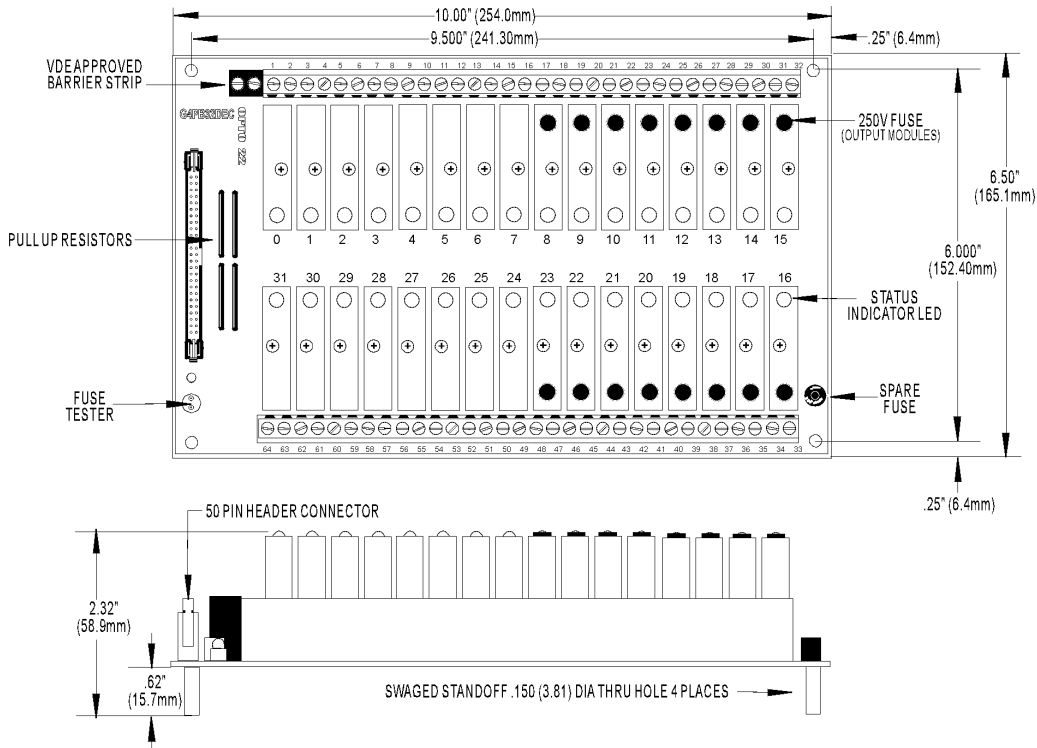

Connections—G4PB32DEC

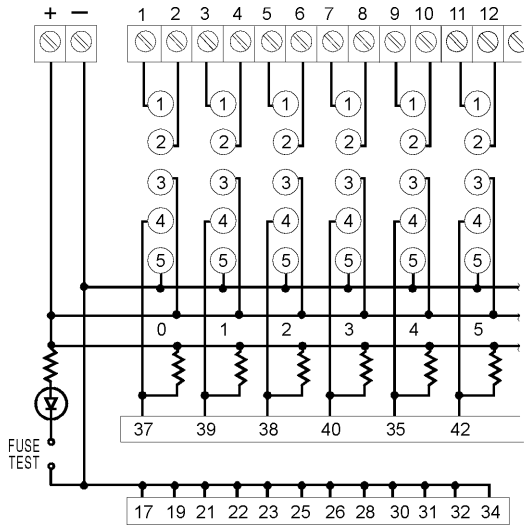

Notes:

1. Pins 17, 19, 21, 22, 23, 25, 26, 28, 30, 31, 32, and 34 on the control connector are etch-connected to the - terminal.
2. +VCC and the return are connected to terminals marked + and -.
3. At each module position on the field terminal strip, the lower number is always connected to pin 1 of the I/O module.
4. The +VCC connection requires +5 VDC.

Module Position	Control (Header Connector)	Field (Terminal Strip)
0	37	1 and 2
1	39	3 and 4
2	38	5 and 6
3	40	7 and 8
4	35	9 and 10
5	42	11 and 12
6	36	13 and 14
7	41	15 and 16
8	47	17 and 18
9	50	19 and 20
10	44	21 and 22
11	48	23 and 24
12	49	25 and 26
13	43	27 and 28
14	46	29 and 30
15	45	31 and 32

Module Position	Control (Header Connector)	Field (Terminal Strip)
16	14	33 and 34
17	12	35 and 36
18	13	37 and 38
19	11	39 and 40
20	16	41 and 42
21	9	43 and 44
22	15	45 and 46
23	10	47 and 48
24	4	49 and 50
25	1	51 and 52
26	7	53 and 54
27	3	55 and 56
28	2	57 and 58
29	8	59 and 60
30	5	61 and 62
31	6	63 and 64

Generation 4 Racks with Integral Digital I/O

Overview of Racks with Integral I/O

This chapter includes information on racks that have permanent I/O circuitry built in. For mounting racks that are used with separate I/O modules, see [page 3](#).

Features

The following features apply to all racks with integral I/O:

- Minimum mounting space required
- UL recognized, CSA certified, and CE compliant
- Uses a single 5 VDC power supply for control power
- Screw-type barrier strip for field connections; 50-pin header connector for control connections
- Operating temperature: -30° to 70° C. Humidity: 95%, non-condensing
- Can be modified for use with the G4AC5 adapter card. See [page 52](#) for more information.

Choose Your Rack

Choose a rack from the following table, then see the referenced page for detailed drawings and specifications.

Model	Number of Channels	Input Modules	Output Modules	AC	DC	Built-in Fuse Tester	Special Features	See
G4PB16J	16	●			●	n/a	Optically isolated 4–16 VDC input channels built in. Use with Optomux B1, Pamux B5, and mastic B100 brain boards. LED indicator for each channel. Logic supply is fused.	page 28
G4PB16K	16	●			●	n/a	Optically isolated 16–28 VDC input channels built in. Use with Optomux B1, Pamux B5, and mistic B100 brain boards. LED indicator and fuse for each channel. Logic supply is fused.	page 28
G4PB16L	16		●		●	●	Optically isolated 5–60 VDC output channels built in. Use with Optomux B1, Pamux B5, and mastic B100 brain boards. LED indicators for each channel.	page 30

G4PB16J and K Racks with Integral Inputs

Description

The G4PB16J and G4PB16K DC input racks provide 16 channels of optically-isolated inputs for sensing on/off DC voltage levels by a B1, B5, or B100 brain board, or any ISA bus-compatible computer with an Opto 22 G4AC5 adapter card. Their compact size and design yields a substantial space and cost savings over other 16-channel I/O boards.

All input channels are identical on each board and are ideal for applications that need to monitor several 4-16 VDC signals (model G4PB16J) or 16-28 VDC signal (model G4PB16K). On-board LED indicators display each channel's on/off status.

Typical applications for the integrated DC input racks include sensing the presence or absence of voltage from sources such as BCD devices, TTL level devices, thumbwheel switches, and barcode readers.

Control connections are easily made to a 50-pin header connector. Barrier strips with screw terminals provide the field and rack power connections. The logic supply is fused with a 1A fuse. These racks can be used with the G4AC5 computer interface if jumpers 1 and 2 are removed. (The figure above right shows the location of these two jumpers. See [page 51](#) for more information.)

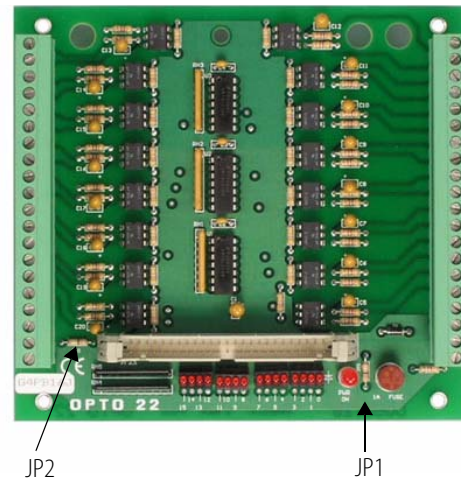

Specifications

	Units	G4PB16J	G4PB16K
Input line voltage	VDC	4–16	16–28
Input current:			
@ Minimum voltage range	mA @ VDC	3.3, 4	3.4, 16
@ Maximum voltage range	mA @ VDC	16, 16	6.3, 28
Isolation:			
Input-to-output (transient)	volts	4,000	4,000
Channel-to-channel	Continuous volts	300	300
Input-to-output capacitance	pF/channel	8	8
Turn-on time	ms	2.5	3
Turn-off time	ms	3.5	4.5
Logic supply voltage	VDC	4.5–6	4.5–6
Logic supply current	mA @ VDC	190, 5	190, 5
Temperature:			
Operating	°C	-30 to +70	-30 to +70
Storage	°C	-30 to +85	-30 to +85

Dimensions—G4PB16J and K

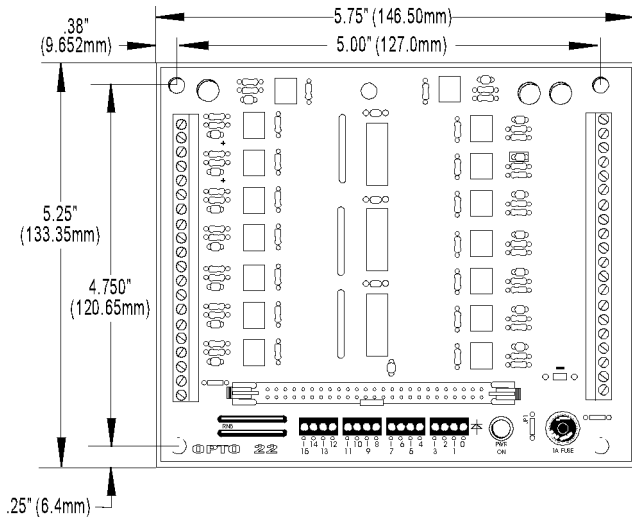

Connections—G4PB16J and K

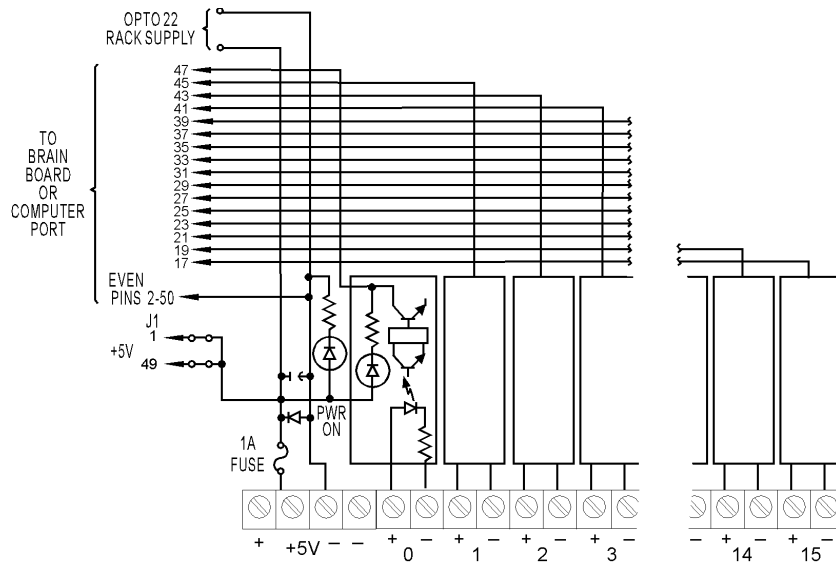

G4PB16L Rack with Integral Outputs

Description

The G4PB16L DC output rack provides 16 channels of optically-isolated outputs for controlling or switching small DC loads by aB1, B5, or B100 brain board, or any ISA bus-compatible computer with an Opto 22 G4AC5 adapter card. Their compact size and design yields a substantial space and cost savings over other 16-channel I/O boards.

All channels are identical on each board and output 5-60 VDC. They are ideal for applications that need to control or switch several similar small DC loads. On-board LED indicators display each channel's on/off status.

Typical applications for the integrated DC output rack include controlling or switching low-power DC relays, low-power DC solenoids, and DC lamps and indicators.

Control connections are easily made to a 50-pin header connector. Barrier strips with screw terminals provide the field and rack power connections. The logic supply and all output channels are individually fused with a 1A fuse. This rack can be used with the G4AC5 computer interface if jumpers 1 and 2 are removed. (The figure above right shows the location of these two jumpers. See [page 51](#) for more information.)

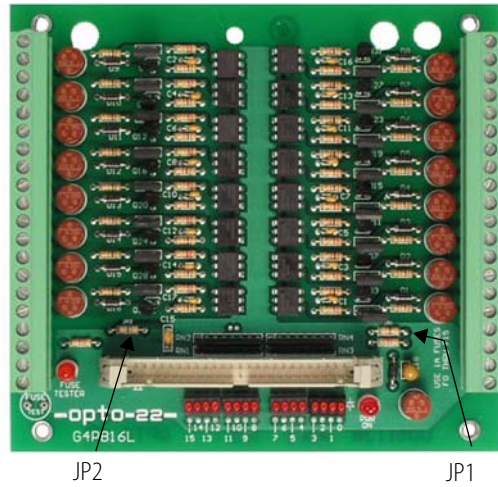

Specifications and Dimensions

Output voltage range	5–60 VDC
Current rating:	
@ 45° C	0.5 A
@ 70° C	0.2 A
Isolation:	
Input-to-output (transient)	4,000 volts
Channel-to-channel	300 volts
Off-state leakage at maximum voltage	1 mA
One-second surge	1.3 A
Turn-on time	100 μsec
Turn-off time	100 μsec
Output voltage drop maximum peak	1.6 VDC
Nominal logic voltage	5 VDC
Logic voltage range	4.5–6 VDC
Logic input current at nominal logic voltage	190 mA
Temperature:	
Operating	-30° to +70° C
Storage	-30° to +85° C

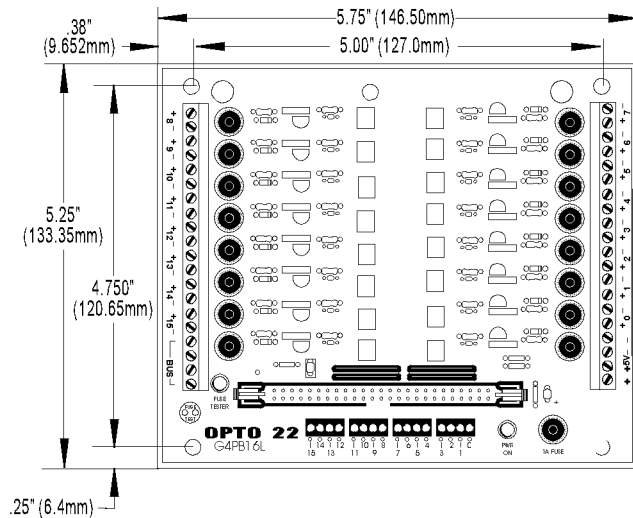

Connections-G4PB16L

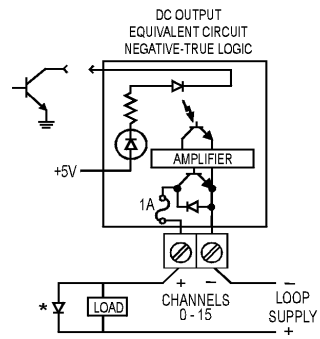
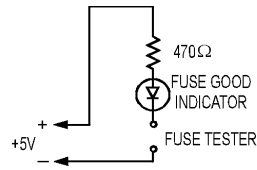
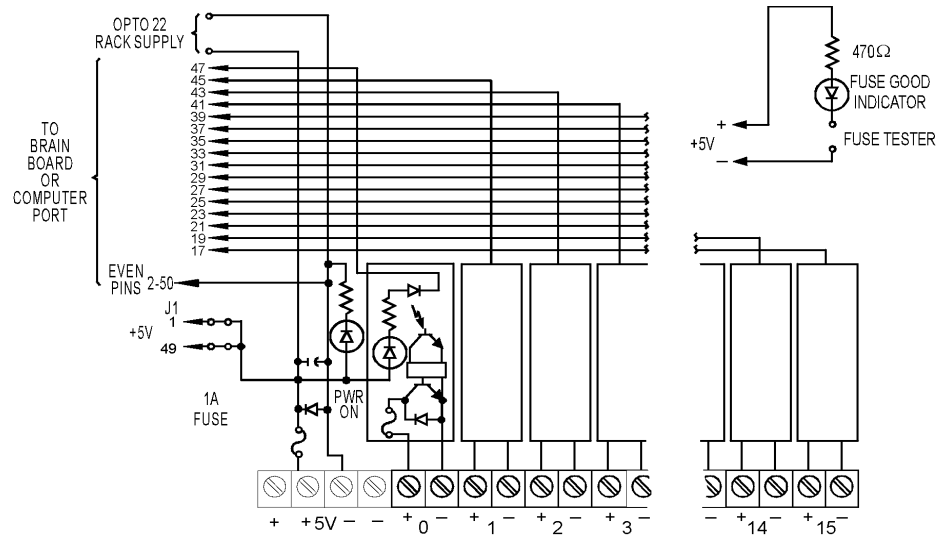

*Note: Commutation diode must be used on inductive loads.
Typically, use diode 1N4005

Generation 4 Digital I/O Modules

Overview of All Modules

Features

The following features apply to all modules:

- Small footprint design, reducing mounting space by approximately 50 percent
- UL recognized, CSA certified, and CE compliant
- Passed NEMA Showering Arc Test (ICS 2-230)
- Meet IEEE Surge Withstand Specification (IEEE-472)
- Operating temperature: - 30° to 70° C.

Choose Your Module

Choose a module from the following table, then see the referenced page for detailed drawings and specifications.

Model	Input	Output	AC	DC	Logic Voltage	Field Voltage	Used for Testing	Special Features	See
G4IDC5	●		● ¹	●	5 VDC	10–32 VDC 12–32 VAC			page 35
G4IDC5B	●			●	5 VDC	4–16 VDC		Higher speed	page 35
G4IDC5D	●			●	5 VDC	2.5–28 VDC		High speed	page 35
G4IDC5G	●		● ¹	●	5 VDC	35–60 VDC/AC			page 35
G4IDC5K	●			●	5 VDC	2.5–16 VDC		Highest speed	page 35
G4IDC5MA	●		● ¹	●	5 VDC	10–32 VDC 12–32 VAC	●	Diagnostic switch	page 35
G4IDC15	●		● ¹	●	15 VDC	10–32 VDC 12–32 VAC			page 35

¹ These DC input modules work with either DC or AC voltages.

² These AC input modules work with either AC or DC voltages.

Model	Input	Output	AC	DC	Logic Voltage	Field Voltage	Used for Testing	Special Features	See
G4IDC24	●		● ¹	●	24 VDC	10–32 VDC 12–32 VAC			page 35
G4IAC5	●		●	● ²	5 VDC	90–140 VAC/DC			page 38
G4IAC5A	●		●	● ²	5 VDC	180–280 VAC/DC			page 38
G4IAC5L	●		●	●	5 VDC	90–140 VAC/DC		Low input resistance	page 38
G4IAC5MA	●		●	● ²	5 VDC	90–140 VAC/DC	●	Diagnostic switch	page 38
G4IAC15	●		●	● ²	15 VDC	90–140 VAC/DC			page 38
G4IAC15A	●		●	● ²	15 VDC	180–280 VAC/DC			page 38
G4IAC24	●		●	● ²	24 VDC	90–140 VAC/DC			page 38
G4IAC24A	●		●	● ²	24 VDC	180–280 VAC/DC			page 38
G4SWIN	●		●	●	NA	NA	●	Simulates input	page 40
G4ODC5		●		●	5 VDC	5–60 VDC			page 41
G4ODC5A		●		●	5 VDC	5–200 VDC			page 41
G4ODC5MA		●		●	5 VDC	5–60 VDC		Diagnostic switch	page 41
G4ODC15		●		●	15 VDC	5–60 VDC			page 41
G4ODC24		●		●	24 VDC	5–60 VDC			page 41
G4ODC24A		●		●	24 VDC	5–200 VDC			page 41
G4OAC5		●	●		5 VDC	120 VAC			page 44
G4OAC5A		●	●		5 VDC	120/240 VAC			page 44
G4OAC5A5		●	●		5 VDC	120/240 VAC		Normally closed	page 44
G4OAC5MA		●	●		5 VDC	120 VAC	●	Diagnostic switch	page 44
G4OAC5AMA		●	●		5 VDC	120/240 VAC	●	Diagnostic switch	page 44
G4OAC15		●	●		15 VDC	120 VAC			page 44
G4OAC15A		●	●		15 VDC	120/240 VAC			page 44
G4OAC24		●	●		24 VDC	120 VAC			page 44
G4OAC24A		●	●		24 VDC	120/240 VAC			page 44
G4ODC5R		●	●	●	5 VDC	NA		Dry contact module (reed relay)	page 47
G4ODC5R5		●	●	●	5 VDC	NA		Dry contact module (reed relay)	page 47
G4SWOUT		●	●	●	NA	NA	●	Simulates output	page 50

¹ These DC input modules work with either DC or AC voltages.

² These AC input modules work with either AC or DC voltages.

Digital DC Input Modules

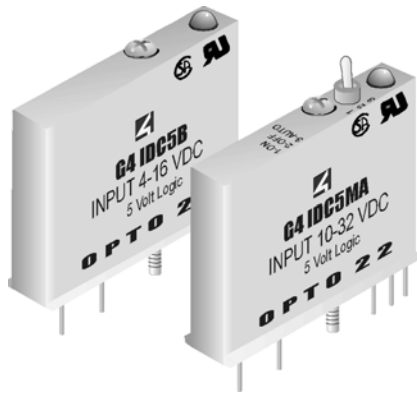

Description

Opto 22's G4 DC input modules are used to detect on/off DC voltage levels. Each module provides up to 4,000 V of optical isolation between field inputs and the logic output of the circuit.

All DC input modules except the G4IDC5K and the G4IDC5D are designed with filtering on the input and a hysteresis amplifier, providing high noise rejection and transient-free, "clean" switching. The G4IDC5K is a fast-switching module used to detect signals produced by photoelectric switches and TTL devices. The low-cost G4IDC5D is used for data acquisition. The G4IDC5MA is a special module featuring a manual-on/manual-off/automatic switch, ideal for diagnostic testing of control applications.

Typical applications for DC input modules include sensing the presence or absence of voltage with devices such as proximity switches, limit switches, selector switches, push buttons, photoelectric switches, and TTL-compatible devices. All modules include a built-in LED status indicator.

Specifications—DC Input Modules

	Units	G4IDC5	G4IDC5B	G4IDC5D	G4IDC5G
Input voltage range	VDC VAC	10–32 12–32	4–16 4–16	2.5–28 —	35–60 35–60
Key feature		—	Higher speed	High speed	—
Input current at maximum line	mA	25	45	30	6
Isolation, input-to-output (transient): 1 ms 1 minute	V V	4000 1500	4000 1500	4000 1500	4000 1500
Turn-on time	ms	5	0.05	1	10
Turn-off time	ms	5	0.1	1.5	10
Input allowed for off-state	mA, V	1, 3	0.7, 1	0.2, 1	0.7, 7
Nominal output supply voltage	VDC	5	5	5	5
Output supply voltage range	VDC	4.5–6	4.5–6	4.5–6	4.5–6
Output supply current at nominal logic voltage	mA	12	12	12	12
Input resistance (R1 in schematic)	ohms	1.5 K	300	900	10 K
Control resistance (Rc in schematic)	ohms	220	220	470	220
Output voltage drop	V @ 50 mA	0.4	0.4	0.4	0.4
Output current (sinking)	mA	50	50	50	50
Output leakage with no input	microamps @ 30 VDC	100	100	10	100
Transistor	V breakdown	30	30	30	30
Temperature: Operating Storage	°C °C	-30 to +70 -30 to +85	-30 to +70 -30 to +85	-30 to +70 -30 to +85	-30 to +70 -30 to +85

Specifications—DC Input Modules (continued)

	Units	G4IDC5K	G4IDC5MA	G4IDC15	G4IDC24
Input voltage range	VDC VAC	2.5–16 —	10–32 12–32	10–32 12–32	10–32 12–32
Key feature		Highest speed	Diagnostic switch	—	—
Input current at maximum line	mA	30	25	25	25
Isolation, input-to-output (transient): 1 ms 1 minute	V V	4000 1500	4000 1500	4000 1500	4000 1500
Turn-on time	ms	0.025*	5	5	5
Turn-off time	ms	0.025*	5	5	5
Input allowed for off-state	mA, V	0.2, 1	1, 3	1, 3	1,3
Nominal output supply voltage	VDC	5	5	15	24
Output supply voltage range	VDC	4.5–6	4.5–6	12–18	20–30
Output supply current at nominal logic voltage	mA	12	12	15	18
Input resistance (R1 in schematic)	ohms	500	1.5 K	1.5 K	1.5 K
Control resistance (Rc in schematic)	ohms	220	220	1 K	2.2 K
Output voltage drop	V @ 50 mA	0.4	0.4	0.4	0.4
Output current (sinking)	mA	50	50	50	50
Output leakage with no input	microamps @ 30 VDC	100	100	100	100
Transistor	V breakdown	30	30	30	30
Temperature: Operating Storage	°C °C	-30 to +70 -30 to +85	-30 to +70 -30 to +85	-30 to +70 -30 to +85	-30 to +70 -30 to +85

* At 5Vp-p square wave input, 50% duty cycle.

Dimensions—DC Input Modules

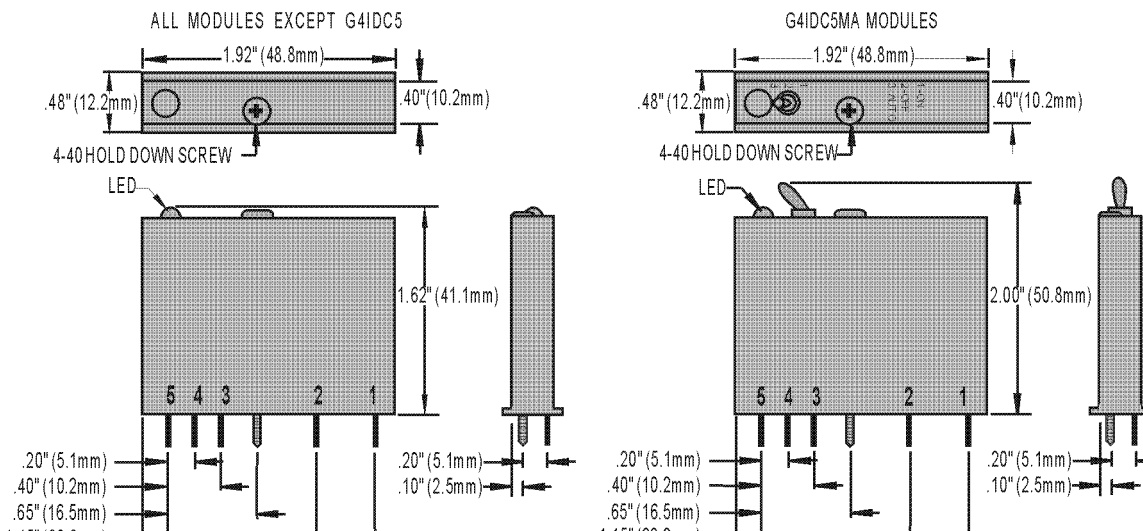

Schematics—DC Input Modules

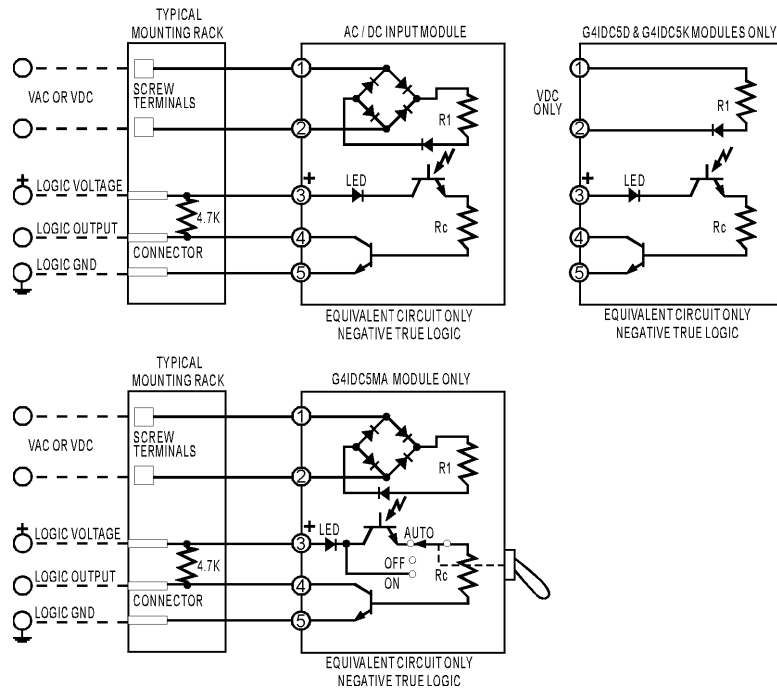

Digital AC Input Modules



Description

Opto 22's G4 AC input modules are used to detect on/off AC voltage levels. Each module provides up to 4,000 volts of optical isolation between field inputs and the logic output of the circuit.

All AC input modules are designed with filtering on the input and a hysteresis amplifier, providing high noise rejection and transient-free "clean" switching. The G4IAC5MA is a special module featuring a manual-on/manual-off/automatic switch, ideal for diagnostic testing of control applications.

Typical applications for AC input modules include sensing the presence or absence of voltage with devices such as proximity switches, limit switches, float switches, selector switches, push buttons, toggle switches, and thermostats. All modules include a built-in LED status indicator.

Specifications—AC Input Modules

	Units	G4IAC5	G4IAC5L	G4IAC5A	G4IAC5MA
Input voltage range	VAC or VDC	90–140	90–140	180–280	90–140
Key feature	--	--	Low R in	--	Diagnostic switch
Input current at maximum line	mA	5	11	5	5
Isolation, input-to-output (transient):					
1 ms	V	4000	4000	4000	4000
1 minute	V	1500	1500	1500	1500
Turn-on time	ms	20	20	20	20
Turn-off time	ms	20	20	20	20
Input allowed for off-state	mA, V	1.4, 40	3, 45	0.7, 45	1.4, 40
Nominal output voltage supply	VDC	5	5	5	5
Output supply voltage range	VDC	4.5–6	4.5–6	4.5–6	4.5–6
Output supply current at nominal logic voltage	mA	12	12	12	12
Input resistance (R ₁ in schematic)	ohms	28 K	14 K	70K	28 K
Control resistance (R _c in schematic)	ohms	220	220	220	220
Output voltage drop	V @ 50 mA	0.4	0.4	0.4	0.4
Output current (sinking)	mA	50	50	50	50
Output leakage with no input	microamps @ 30 VDC	100	100	100	100
Transistor	V breakdown	30	30	30	30
Temperature					
Operating:	°C	-30 to +70	-30 to +70	-30 to +70	-30 to +70
Storage:	°C	-30 to +85	-30 to +85	-30 to +85	-30 to +85

Specifications—AC Input Modules (continued)

	Units	G4IAC15	G4IAC15A	G4IAC24	G4IAC24A
Input voltage range	VAC or VDC	90–140	180–280	90–140	180–280
Key feature	--	--	--	--	--
Input current at maximum line	mA	5	5	5	5
Isolation, input-to-output (transient):					
1 ms	V	4000	4000	4000	4000
1 minute	V	1500	1500	1500	1500
Turn-on time	ms	20	20	20	20
Turn-off time	ms	20	20	20	20
Input allowed for off-state	mA, V	1.4, 40	0.7, 45	1.4, 40	0.7, 45
Nominal output supply voltage	VDC	15	15	24	24
Output supply voltage range	VDC	12–18	12–18	20–30	20–30
Output supply current at nominal logic voltage	mA	15	15	15	15
Input resistance (R1 in schematic)	ohms	28 K	70 K	28 K	70 K
Control resistance (Rc in schematic)	ohms	1 K	1 K	2.2 K	2.2 K
Output voltage drop	V @ 50 mA	0.4	0.4	0.4	0.4
Output current (sinking)	mA	50	50	50	50
Peak repetitive voltage	VAC	500	500	500	500
Output leakage with no input	microamps @ 30 VDC	100	100	100	100
Transistor	V breakdown	30	30	30	30
Temperature					
Operating:	°C	-30 to +70	-30 to +70	-30 to +70	-30 to +70
Storage:	°C	-30 to +85	-30 to +85	-30 to +85	-30 to +85

Dimensions—AC Input Modules

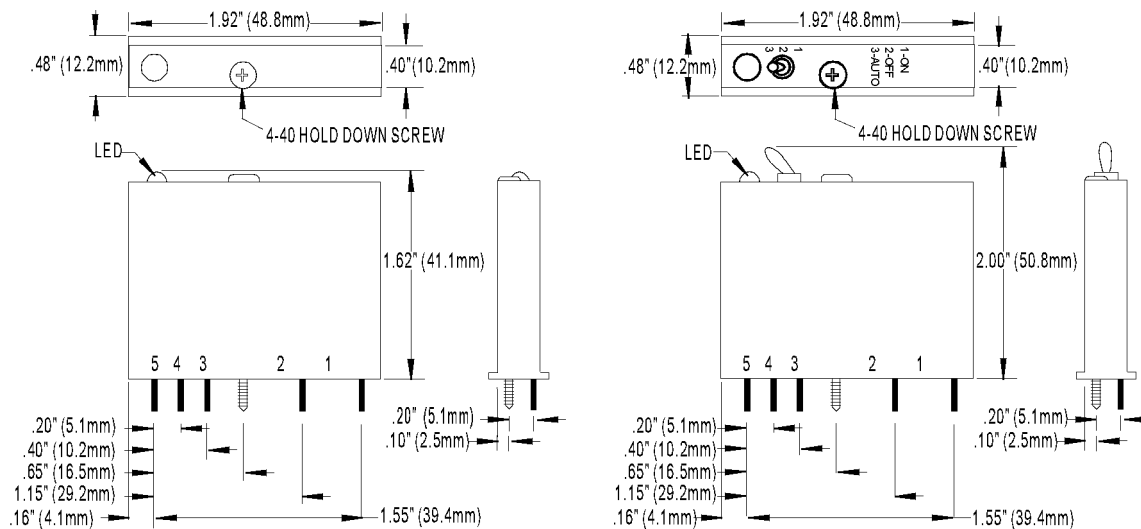

Schematics—AC Input Modules

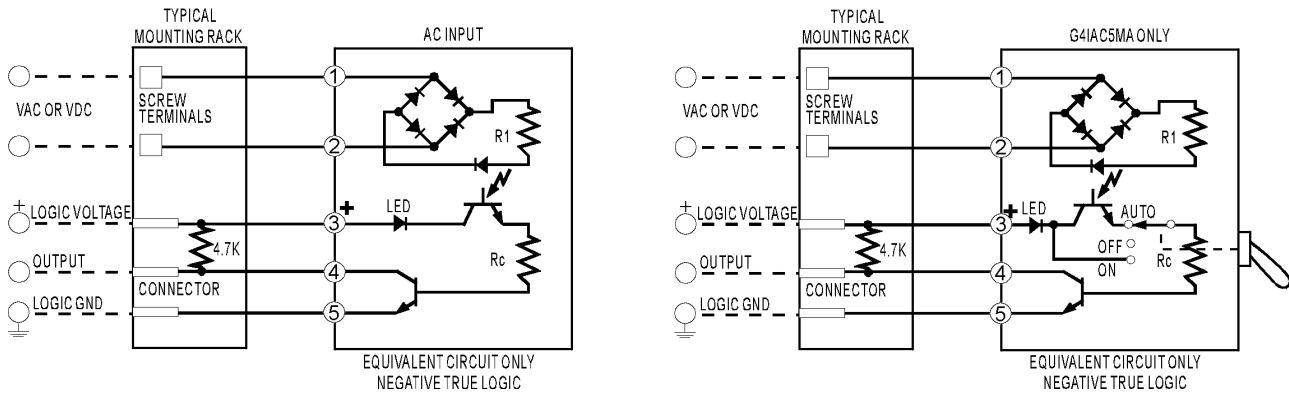

Digital Input Test Module

Description



Opto 22's G4SWIN input test module is used to simulate an input on an I/O mounting rack. Each module contains a toggle switch that closes a contact on the logic side. An internal resistor limits the current through the switch and provides a load similar to that of an actual input module. An internal debounce circuit allows rapid switch closures without false counts.

The G4SWIN module works with logic voltages of 5, 15, and 24 volts. Internally, there is no connection to the field inputs. A built-in LED indicates the simulated on/off status.

This module is ideal for simulating discrete external events when testing application software.

Specifications—Digital Input Test Module

Isolation, input-to-output (transient): 1 ms	4000 volts
1 minute	1500 volts
Temperature:	
Operating	-30 to +70 °C
Storage	-30 to +85 °C

Dimensions and Schematics—Digital Input Test Module

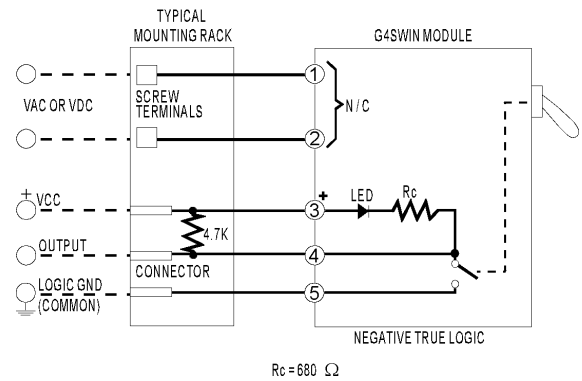
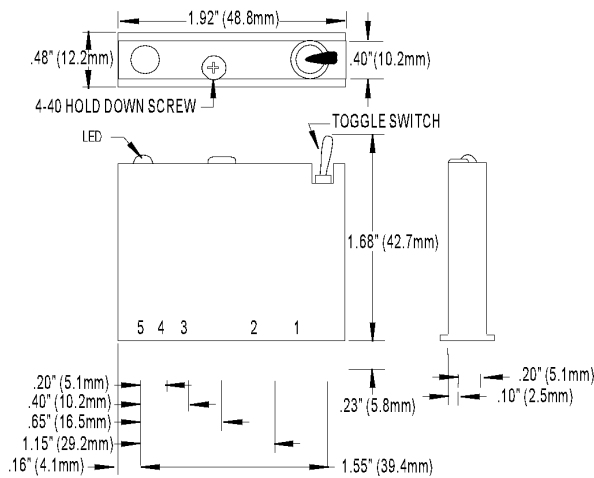

Digital DC Output Modules

Description

Opto 22's G4 DC output modules are used to control or switch DC loads. Each module provides up to 4,000 volts of optical isolation between field devices and control logic.

The G4ODC5MA is a special module featuring a manual-on/manual-off/automatic switch, ideal for diagnostic testing of control applications.

Typical applications for DC output modules include switching loads such as DC relays, solenoids, motor starters, lamps, and indicators. All modules include a built-in LED status indicator.



Specifications—DC Output Modules

	Units	G4ODC5 G4ODC5FM*	G4ODC5A G4ODC5AFM*	G4ODC5MA	G4ODC15	G4ODC24	G4ODC24A
Maximum line voltage	VDC	60	200	60	60	60	200
Output voltage range	VDC	5–60	5–200	5–60	5–60	5–60	5–200
Key feature	—	—	—	Diagnostic switch	—	—	—
Current rating: At 45 °C ambient At 70 °C ambient	A A	3 2	1 0.55	3 2	3 2	3 2	1 0.55
Isolation input-to-output (transient): 1 ms 1 minute	volts	4000 1500	4000 1500	4000 1500	4000 1500	4000 1500	4000 1500
Off-state leakage at maximum voltage	mA	1	1	1	1	1	1
Control resistance (R _C in schematic)	W	220	220	220	1 K	2.2 K	2.2 K
One-second surge	A	5	5	5	5	5	5
Turn-on time	micro-seconds	100	100	100	100	100	100
Turn-off time	micro-seconds	750	750	750	750	750	750
Output voltage drop maximum peak	V	1.6	1.6	1.6	1.6	1.6	1.6
Nominal logic voltage	VDC	5	5	5	15	24	24
Logic voltage range	VDC	4–8	4–8	4–8	10.5–16	19.5–32	19.5–32
Logic pickup voltage	VDC	4	4	4	10.5	19.5	19.5
Logic dropout voltage	VDC	1	1	1	1	1	1
Logic input current at nominal logic voltage	mA	12	12	12	15	18	18
Temperature: Operating Storage	°C °C	-30 to +70 -30 to +85	-30 to +70 -30 to +85	-30 to +70 -30 to +85	-30 to +70 -30 to +85	-30 to +70 -30 to +85	-3- to +70 -30 to +85
*Part numbers ending in FM are Factory Mutual approved.							

Dimensions—DC Output Modules

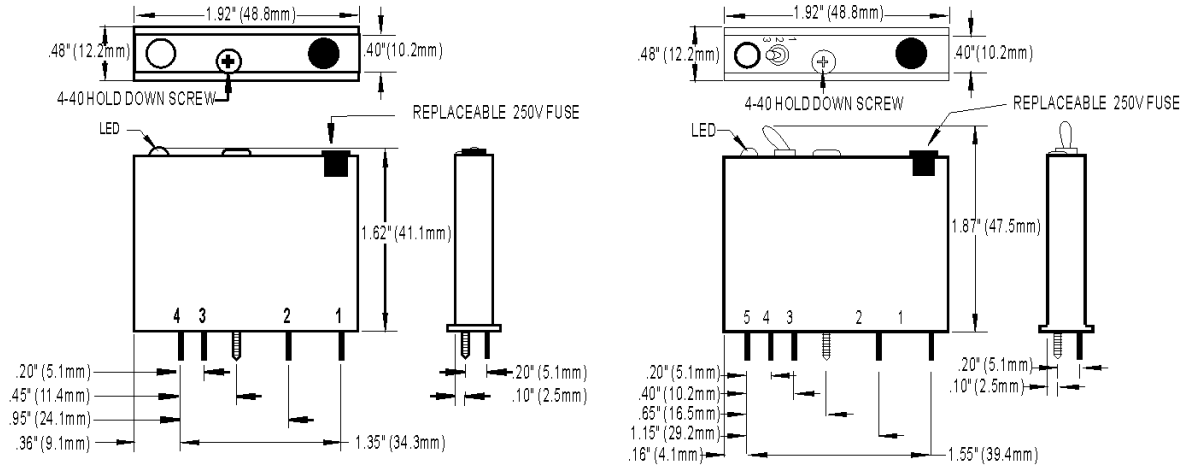

Schematics—DC Output Modules

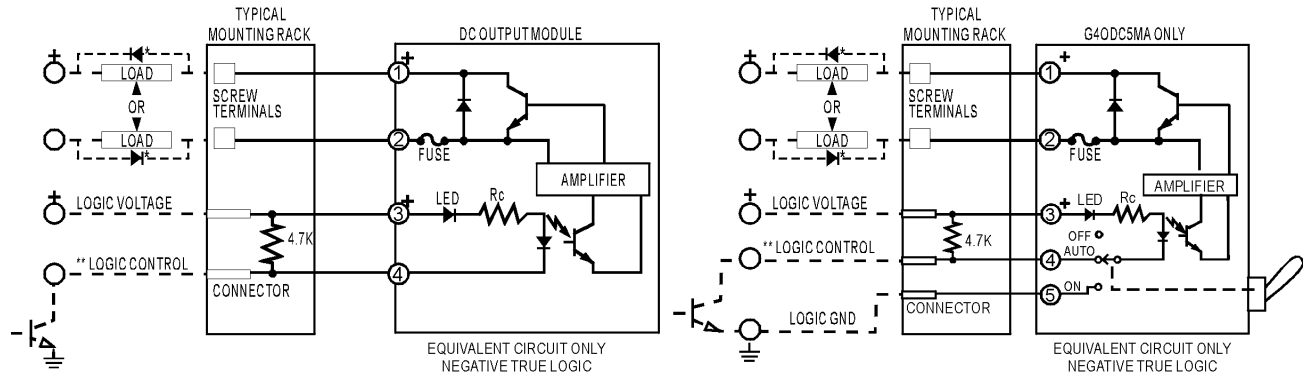

* Commutation diode must be used on inductive loads. Typically, use diode IN4005.
 ** Control line is compatible with totem pole or tri-state output device.

Digital AC Output Modules

Description

Opto 22's G4 AC output modules are used to control or switch AC loads. Each module provides up to 4,000 volts of optical isolation between field outputs and the control side of the circuit, and each features zero voltage turn-on and zero current turn-off. All AC output modules are equivalent to single-pole, single-throw, normally open contacts (Form A, SPST-NO) except the G4OAC5A5, which is equivalent to a single-pole, single-throw, normally closed contact (Form B, SPST-NC).

The G4OAC5MA and the G4OAC5AMA are special modules featuring a manual-on/manual-off/automatic switch, ideal for diagnostic testing of control applications.

Typical applications for AC output modules include switching loads such as AC relays, solenoids, motor starters, heaters, lamps, and indicators. All digital AC output modules include a built-in LED status indicator.



Specifications—AC Output Modules

	Units	G4OAC5 G4OAC5FM*	G4OAC5A G4OAC5AFM*	G4OAC5A5 G4OAC5A5FM*	G4OAC5MA	G4OAC5AMA
Nominal line voltage	VAC	120	120/240	120/240	120	120/240
Output voltage range	VAC	12–140	24–280	24–280	12–140	24–280
Key feature	—	—	—	Normally closed	Diagnostic switch	Diagnostic switch
Current rating:						
At 45 °C ambient	A	3	3	3	3	3
At 70 °C ambient	A	2	2	2	2	2
UL Motor Load Rating	A	1.5	1.5	1.5	1.5	1.5
Isolation input-to-output (transient):						
1 ms	volts	4000	4000	4000	4000	4000
1 minute		1500	1500	1500	1500	1500
Off-state leakage at nominal voltage (60 Hz)	mA _{RMS}	5	1.25/2.5	1.25/2.5	5	1.25/2.5
Nominal logic voltage	VDC	5	5	5	5	5
Logic voltage range	VDC	4–8	4–8	4–8	4–8	4–8
Logic pickup voltage	VDC	4	4	4	4	4
Logic dropout voltage	VDC	1	1	1	1	1
Logic input current at nominal logic voltage	mA	12	12	12	12	12
Control resistance (R _c in schematic)	ohms	220	220	220	220	220
One-cycle surge	A peak	80	80	80	80	80
Turn-on time @ 60 Hz	milliseconds	≤8.3**	≤8.3**	≤8.3**	≤8.3**	≤8.3**

	Units	G4OAC5 G4OAC5FM*	G4OAC5A G4OAC5AFM*	G4OAC5A5 G4OAC5A5FM*	G4OAC5MA	G4OAC5AMA
Turn-off time @ 60 Hz	milliseconds	≤8.3***	≤8.3***	≤8.3***	≤8.3***	≤8.3***
Peak repetitive voltage	VAC	500	500	500	500	500
Minimum load current	mA	20	20	20	20	20
Output voltage drop maximum peak	V	1.6	1.6	1.6	1.6	1.6
Operating frequency	Hz	25–65	25–65	25–65	25–65	25–65
dV/dT-off-state	V/micro-seconds	200	200	200	200	200
dV/dT-commutating	--	snubbed for 0.5 power factor load	snubbed for 0.5 power factor load	snubbed for 0.5 power factor load	snubbed for 0.5 power factor load	snubbed for 0.5 power factor load
Temperature Operating:	°C	-30 to +70	-30 to +70	-30 to +70	-30 to +70	-30 to +70
Storage:	°C	-30 to +85	-30 to +85	-30 to +85	-30 to +85	-30 to +85

* Part numbers ending in FM are Factory Mutual approved.

** One-half cycle maximum. Module turns on at the zero volt crossing of the AC sine wave.

*** One-half cycle maximum. Module turns off at the zero current crossing of the AC sine wave.

Specifications—AC Output Modules (continued)

	Units	G4OAC15	G4OAC15A	G4OAC24	G4OAC24A
Nominal line voltage	VAC	120	120/240	120	120/240
Output voltage range	VAC	12–140	24–280	12–140	24–280
Key feature	—	—	—	—	—
Current rating:					
At 45 °C ambient	A	3	3	3	3
At 70 °C ambient	A	2	2	2	2
UL Motor Load Rating	A	1.5	1.5	1.5	1.5
Isolation input-to-output (transient):					
1 ms	volts	4000	4000	4000	4000
1 minute		1500	1500	1500	1500
Off-state leakage at nominal voltage (60 Hz)	mA _{RMS}	5	1.25/2.5	5	1.25/2.5
Logic voltage range	VDC	10.5–16	10.5–16	19.5–32	19.5–32
Logic pickup voltage	VDC	10.5	10.5	19.5	19.5
Logic dropout voltage	VDC	1	1	1	1
Logic input current at nominal logic voltage	mA	15	15	18	18
Control resistance (Rc in schematic)	ohms	1 K	1 K	2.2 K	2.2 K
One-cycle surge	A peak	80	80	80	80
Turn-on time @ 60 Hz	micro-seconds	≤8.3*	≤8.3*	≤8.3*	≤8.3*
Turn-off time @ 60 Hz	micro-seconds	≤8.3**	≤8.3**	≤8.3**	≤8.3**

* One-half cycle maximum. Module turns on at the zero volt crossing of the AC sine wave.

** One-half cycle maximum. Module turns off at the zero current crossing of the AC sine wave.

	Units	G4OAC15	G4OAC15A	G4OAC24	G4OAC24A
Peak repetitive voltage	VAC	500	500	500	500
Minimum load current	mA	20	20	20	20
Output voltage drop maximum peak	V	1.6	1.6	1.6	1.6
Operating frequency	Hz	25–65	25–65	25–65	25–65
dV/dT-off-state	V/micro-second	200	200	200	200
dV/dT-commutating	--	snubbed for 0.5 power factor load	snubbed for 0.5 power factor load	snubbed for 0.5 power factor load	snubbed for 0.5 power factor load
Temperature Operating:	°C	-30 to +70	-30 to +70	-30 to +70	-30 to +70
Storage:	°C	-30 to +85	-30 to +85	-30 to +85	-30 to +85

* One-half cycle maximum. Module turns on at the zero volt crossing of the AC sine wave.

** One-half cycle maximum. Module turns off at the zero current crossing of the AC sine wave.

Dimensions—AC Output Modules

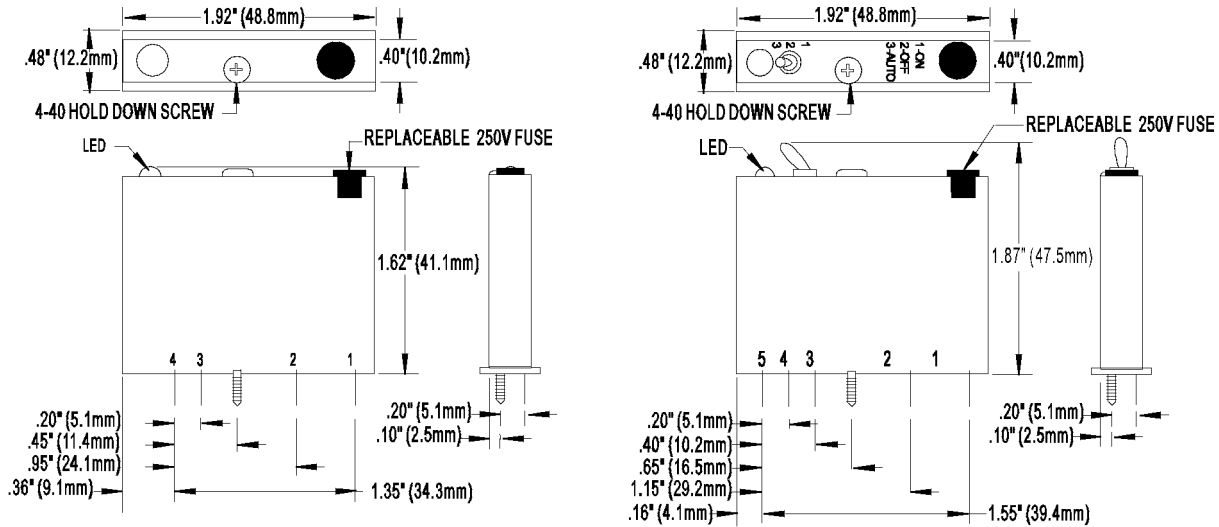

Schematics—AC Output Modules

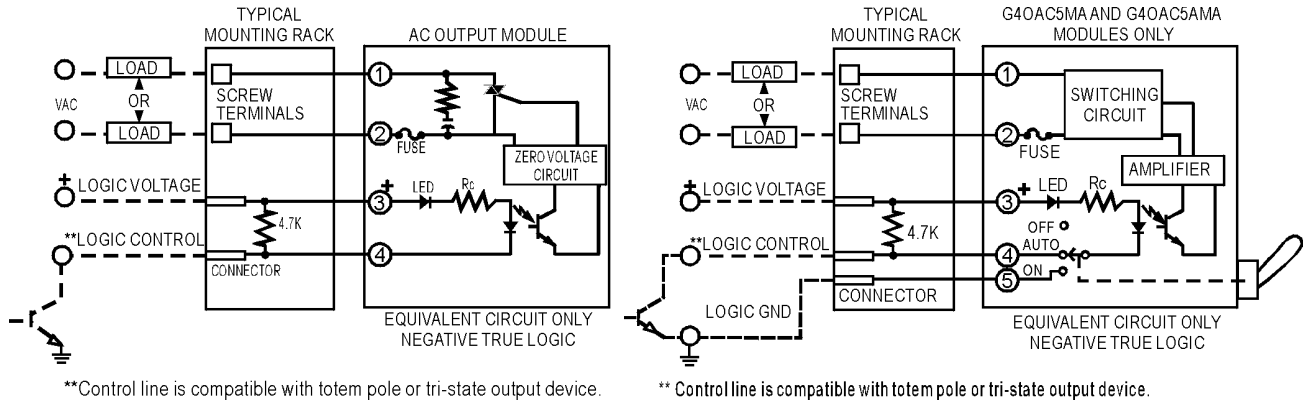

Dry Contact Output Modules



Description

Opto 22's G4 family of modules includes two dry-contact, low contact-resistance DC output modules: the G40DC5R and the G40DC5R5.

The G40DC5R is a single-pole, single-throw, normally *open* mechanical relay (Form A, SPST-NO). The G40DC5R5 is a single-pole, single-throw, normally *closed* mechanical relay (Form B, SPST-NC).

Typical applications for these dry-contact modules include analog signal and communication line multiplexing.

Specifications—Dry Contact Output Modules

	Units	G4ODC5R G4ODC5RFM ^{1,2}	G4ODC5R5 G4ODC5R5FM ^{1,2}
Contact form		Form A SPST mechanical relay	Form B SPST mechanical relay
Normal position		Open	Closed
Contact rating	VA	10	10
Maximum switching voltage	VDC	100	100
	VAC	130	130
Maximum switching current	A	0.5	0.5
Maximum carry current	A	1.5	1.5
Contact resistance	Megohms	200	200
Turn-on time	microseconds	500	500
Turn-off time	microseconds	500	500
Contact bounce	microseconds	250	250
Mechanical life	cycles	5x10 ⁶	5x10 ⁶
Logic voltage range	VDC	4.8–6	4.8–6
Logic pickup voltage ¹	VDC	0.8	0.8
Logic dropout voltage ¹	VDC	3.8	3.8
Logic input current at nominal logic voltage	milliamps	14	14
Isolation voltage (transient) input-to-output	VDC	1,500	1,500
Ambient temperature:			
	Operating	°C	0 to 70
Storage	°C	-60 to +105	0 to 70 -60 to +105

¹Pickup and dropout voltages are measured from 5 VDC logic ground.

²Part numbers ending in FM are Factory Mutual approved.

NOTE: The power rating of the dry contact module must not exceed 10 VA under steady-state or momentary in-rush conditions.

For voltages at or below 20 volts, the current limit is 0.5 amps. For voltages above 20 volts, the maximum allowable current is determined by the following equation:

$$\frac{10 \text{ VA}}{\text{voltage}} = \text{Current maximum}$$

See next page for additional information.

Specifications—Dry Contact Output Modules (continued)

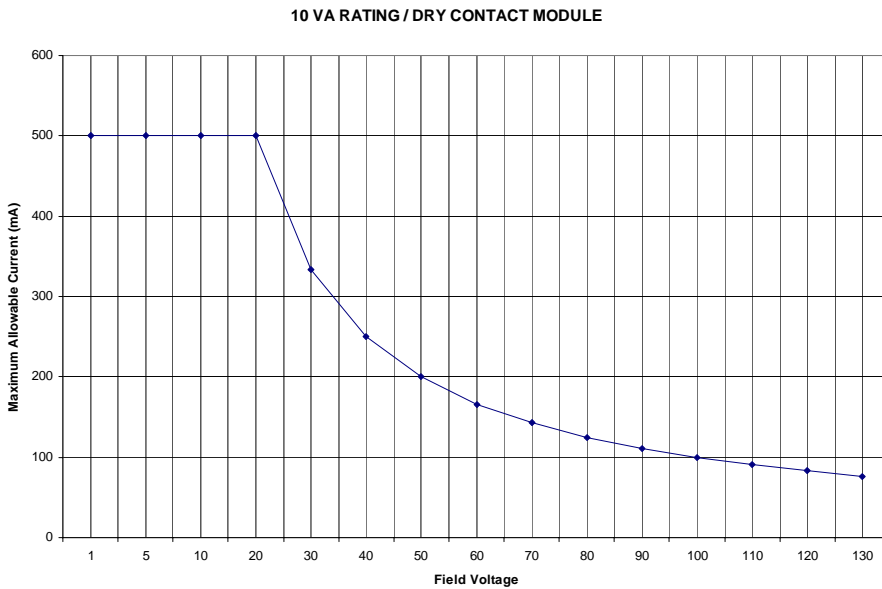

Current Limit at Key Voltages:

V	mA
5	500
12	500
24	416
100 ¹	100
120	83
130 ²	76

¹ Maximum DC voltage is 100 VDC.

² Maximum AC voltage is 130 VAC.

Dimensions and Schematics—Dry Contact Output Modules

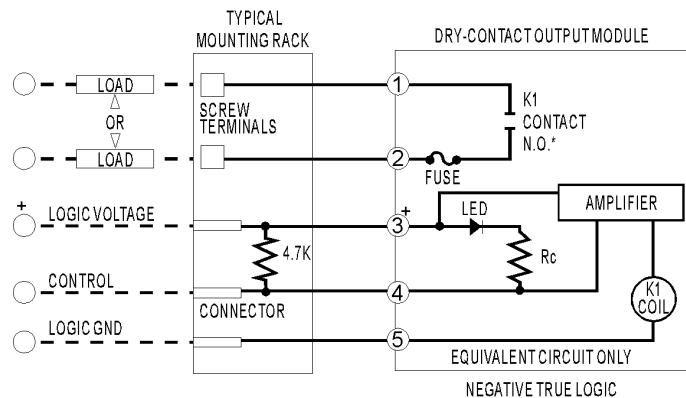
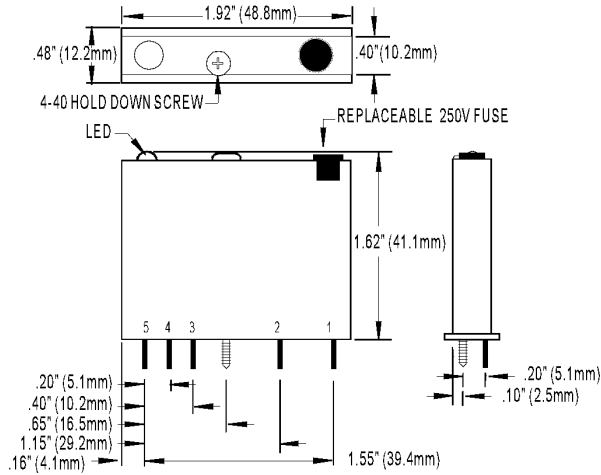

Note: Also compatible with Totem Pole or Tri-State Output.
Will not plug into G4PB4R mounting rack.

* Normally open for G40DC5R, normally closed for G40DC5R5.

Digital Output Test Module



Description

Opto 22's G4SWOUT output test module is used to simulate a G4 output on an I/O mounting rack. Each module contains a manual toggle switch on the field side. The switch closes a contact that shorts the field terminals to turn on a field output. Internally, there is no connection to the logic side of the module.

The G4SWOUT module is ideal for testing field wiring and devices by simulating an output from the computer. The switch handles 3 amps at 250 VAC/VDC.

Specifications—Output Test Module

Output voltage range	250 VAC/VDC
Isolation, input-to-output (transient)	4000 volts
Temperature: Operating Storage	-30 to +70 °C -30 to +85 °C

Dimensions and Schematics—Output Test Module

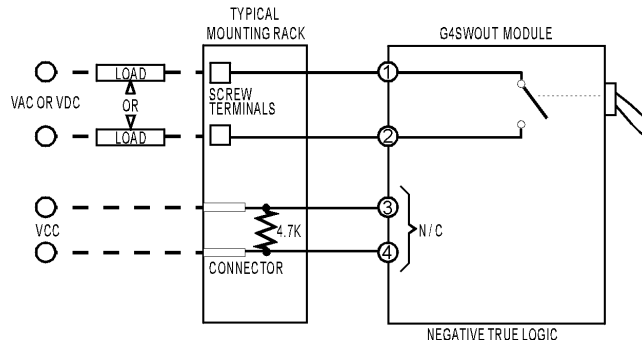
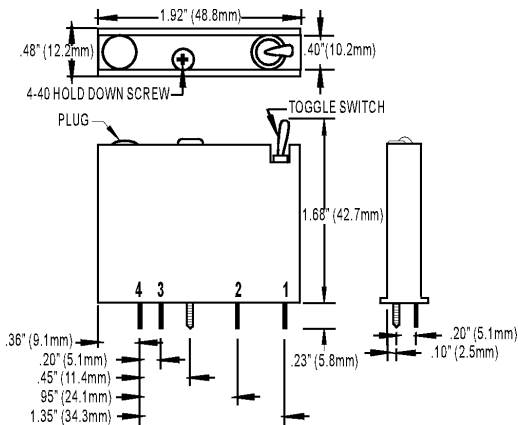

Generation 4 Digital I/O Accessories

Overview of Accessories

Accessories for Generation 4 I/O include the following:

- Adapter card—see below.
- Cables and connectors—see [page 53](#).
- Fuses—see [page 54](#).
- Jumper strap—see [page 54](#).

PC to I/O Mounting Rack Adapter Card (G4AC5)

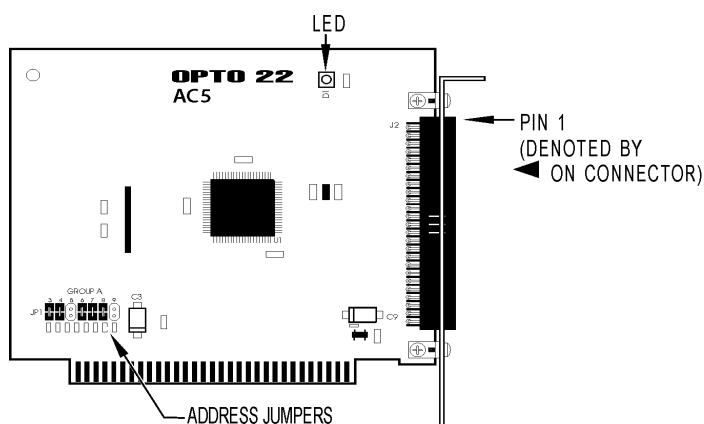

Description

The G4AC5 adapter card provides an interface between the PC and Opto 22 digital I/O mounting racks. As many as four G4AC5 adapter cards can be installed per PC.

A 50-conductor ribbon cable, supplied with the adapter card, connects the adapter to an I/O rack with header-style connectors

Requirements

- An external 5VDC power supply is required at the I/O mounting rack. This power cannot be provided by the G4AC5. Opto 22 recommends the use of a **linear** power supply for this purpose.
- A software driver is required to access the G4AC5 from Windows NT or when using Visual Basic on any operating system. For more information, contact Opto 22 Product Support. (See [page 2](#).)

Rack Part Numbers for the G4AC5 Adapter Card

Fully Compatible Racks

The following racks are compatible with the G4AC5 adapter card:

- G4PB8
- G4PB16
- G4PB24

Racks That Can Be Modified

The following racks can be modified for use with the G4AC5 by removing the jumpers to pins 1 and 49. (These jumpers are labeled JP1 and JP2 on racks G4PB16J, G4PB16K, and G4PB16L.) Jumpers can be de-soldered or clipped.

WARNING: If these jumpers are not removed, the power-on LED will be lit regardless of the actual 5-volt power status. This can result in a false power-on indication and may cause damage to the PC.

- G4PB16J
- G4PB16K
- G4PB16L

Incompatible Racks

The following racks are NOT compatible with the G4AC5 because they do not have jumpers that can be removed. The rack's power-on LED will be lit regardless of the actual 5-volt power status. This can result in a false power-on status.

WARNING: Using any of these racks with the G4AC5 may cause damage to the PC.

- G4PB8H
- G4PB16H
- G4PB16HC

Cables and Connectors

Description

Opto 22 supplies several standard cables to interface with host controllers. There are three series of cables, each available in standard lengths. All three cable types use 50-conductor ribbon cable.

Each series of cables is designated according to the type of connector on each end.

- The HH series has a header connector on both ends.
- The CA series has an edge connector on both ends.
- The OD series has a header connector on one end and a card edge connector on the other.

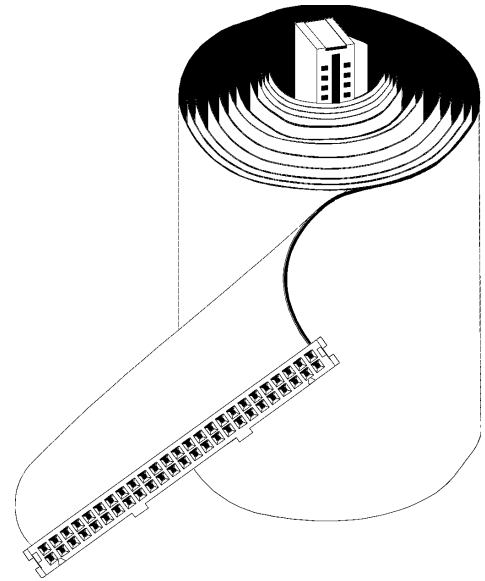

Specifications

Length (feet)	Series Part Numbers		
	HH (Header to header)	CA (Card edge to card edge)	OD (Header to card edge)
1.5	HH1.5	--	--
2	--	CA2	OD2
4	HH4	CA4	OD4
6	HH6	CA6	OD6
8	HH8	CA8	OD8
10	HH10	CA10	OD10

Building Your Own Cables

If the standard cables do not meet your requirements, the following list of manufacturers can help you choose connectors and cable. Contact the manufacturer's distributor for more information.

50-Conductor Cables:

3M P/N 3365/50
ALPHA P/N 3580/50 or 3583/50

Header Connectors:

Circuit Assemblies, Inc. P/N CA50IDS2-C-SPT

Edge Connectors:

3M P/N 3415-0001
Panduit P/N 055-050-455

Connectors with Strain Reliefs:

Use only Panduit Corporation parts P/N 050A050-455

Fuses

Description

Generation 4 output modules use a 4-amp fuse mounted on the module. Each mounting rack includes one spare module fuse.

Additional fuses can be ordered from Opto 22 or directly from Wickmann, at phone number (404) 699-7820.



Ordering Guide

Part Number	Description
FUSEG4	4-amp fuse for Generation 4 output modules (Wickmann, P/N 19370K)
FUSE01G4	1-amp fuse for Generation 4 digital logic power and brick power regulators (Wickmann, P/N 19373-1A)

Jumper Strap

Description

Jumper straps are used to simplify wiring in applications that require a common connection between each I/O module position. The G4STRAP can be used on all G4 digital I/O mounting racks. (It does not work with the G4PB16J, G4PB16K, or G4PB16L racks with integral I/O, however.) The jumper strap has an insulated coating and can be cut to size.



Dimensions

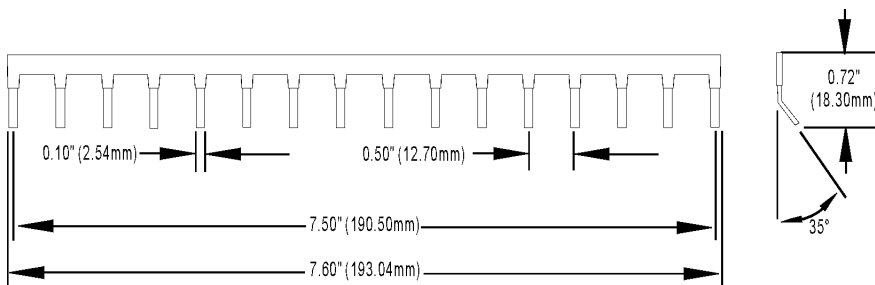

Designing Custom I/O Mounting Racks

Introduction

Customers designing their own mounting systems for Generation 4 digital I/O modules may find the following information helpful. Circuit board layout information and a circuit board parts list are provided to help you get started.

Refer to individual module information in [“Generation 4 Digital I/O Modules”](#) on page 33 for additional specifications.

Dimensions

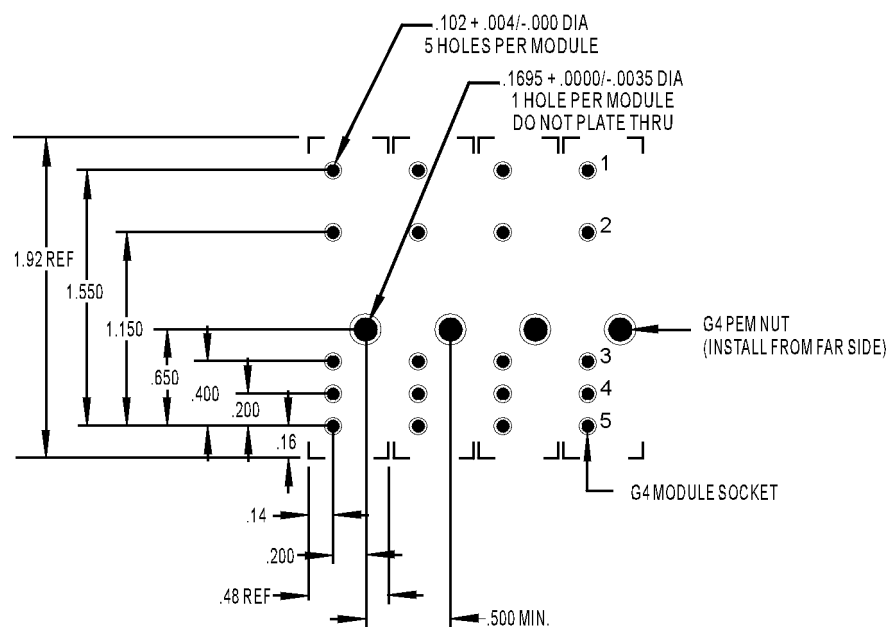

Printed Circuit Patterns

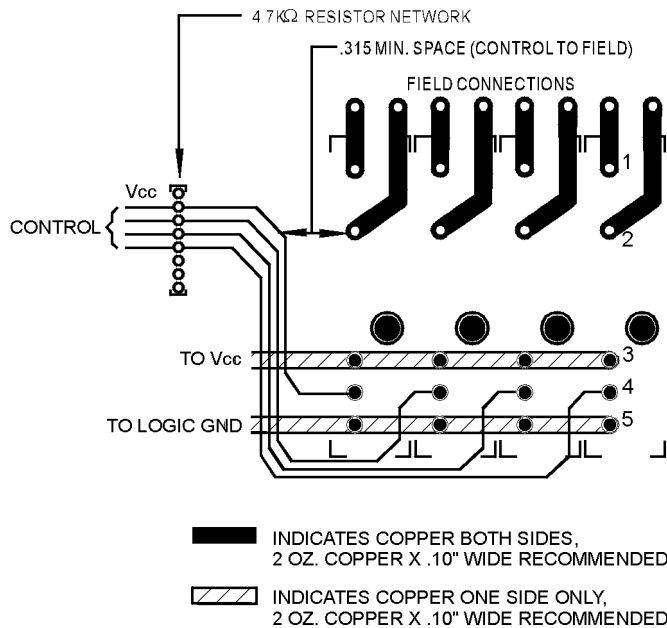

Parts List

Item	Notes	Manufacturer's Part Number	Opto 22 Part Number
G4 module sockets	Five required for each module position	Elpakco, Inc. P/N 4315-TG	G4-MOD-SOCKETS (Qty. 100)
G4 fuse sockets	Two required for each spare fuse ¹	Elpakco, Inc. P/N A2122	G4 FUSE SOCKETS (Qty. 100)
G4 pem nuts	One required for each module position	PEM Fastening Systems KF2-440ET	G4-PEM-NUTS (Qty. 100)
G4 barrier strip	24-position strip ²	Phoenix Contact MKDS5/X ³ -6.35	(see note 4)

¹ Hole size is 0.052 + 0.003/-0.001 diameter on 0.200 centers.

² Hole size is 0.052 + 0.003/-0.001 diameter on 0.500 centers.

³ X in the part number is the number of positions in the barrier strip.

⁴ See Phoenix Contact (information below)

Elpakco, Inc.
www.elpakco.com
2 Carl Thompson Rd.
Westford, MA 01886

PEM Fastening Systems
www.pemnet.com
5190 Old Easton Rd.
Danboro, PA 18916

Phoenix Contact
www.phoenixcontact.com
P.O. Box 4100
Harrisburg, PA 17111-0100

(978) 392-0400
(978) 392-6814 (fax)

(215) 766-8853
(215) 766-3633 (fax)

(717) 944-1300
(717) 944-1625 (fax)

Wiring Diagrams

Input Modules Using DC Field Voltages

Use the diagrams on this page for the following modules:

G4IDC5	G4IDC5G	G4IAC5
G4IDC5B	G4IDC5K	G4IAC5A
G4IDC5D	G4IDC5MA	G4IC5MA

NOTE: The AC input modules listed at left will work with either AC or DC field voltages. If you are using them with AC voltages, see [page 58](#). If you are using them with DC field voltages, follow the diagrams on this page.

On 4-Position Mounting Racks (G4PB4 and G4PB4R)

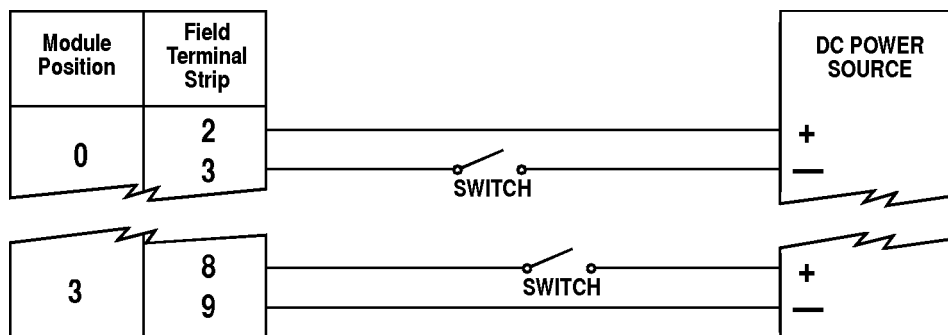

On All Other Mounting Racks

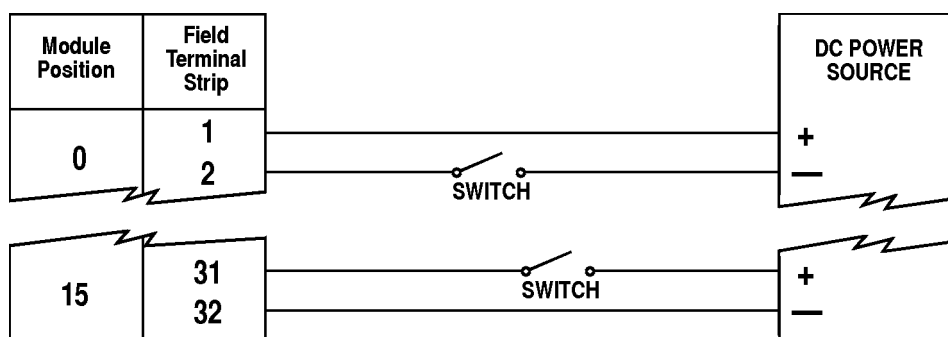

Input Modules Using AC Field Voltages

Use the diagrams on this page for the following modules:

- G4IAC5 G4IDC5
- G4IAC5A G4IDC5G
- G4IAC5MA G4ID5MA

NOTE: The DC input modules listed at left will work with either DC or AC field voltages. If you are using them with DC voltages, see [page 57](#). If you are using them with AC field voltages, follow the diagrams on this page.

On 4-Position Mounting Racks (G4PB4 and G4PB4R)

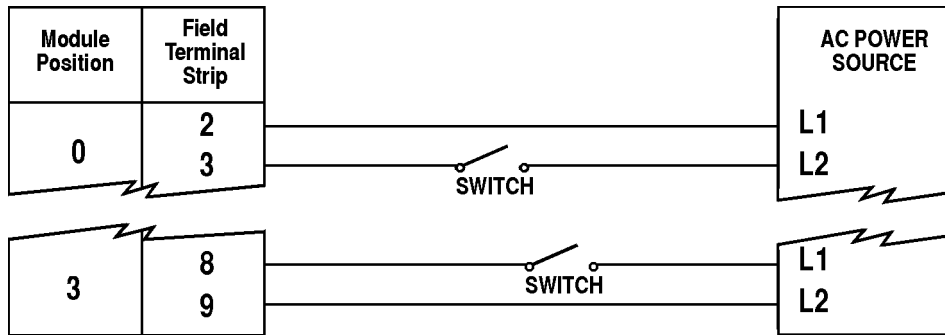

On All Other Mounting Racks

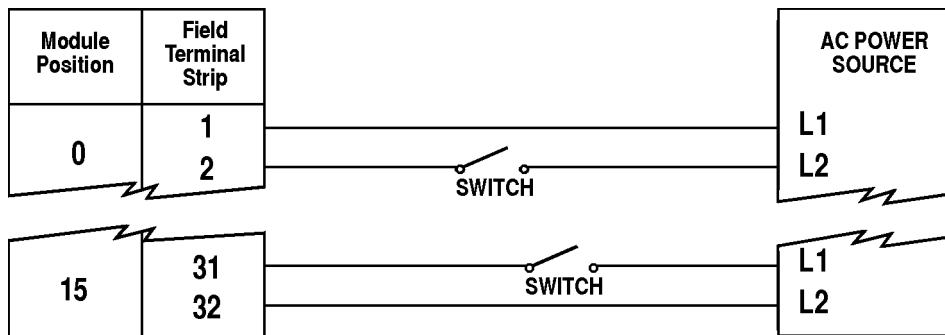

Output Modules Using DC Field Voltages

Use the diagrams on this page for the following modules:

- G40DC5
- G40DC5A
- G40DC5MA

On 4-Position Mounting Racks (G4PB4 and G4PB4R)

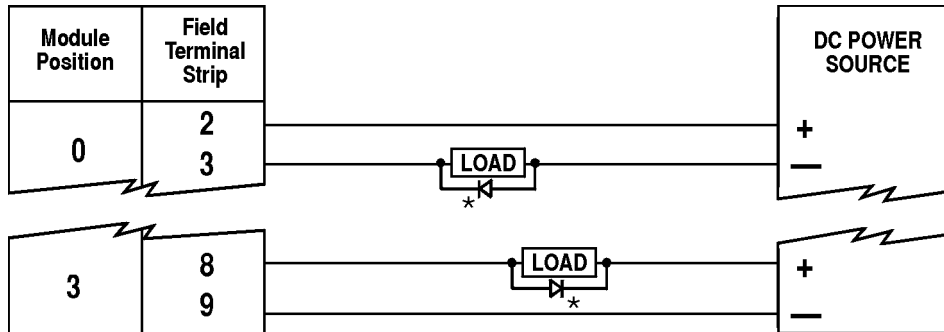

*Note: Commutation diode must be used on inductive loads. Typically, use diode 1N4005

On All Other Mounting Racks

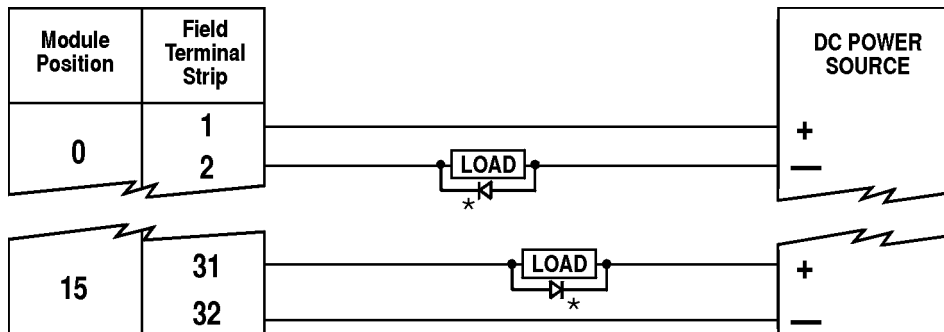

*Note: Commutation diode must be used on inductive loads. Typically, use diode 1N4005

Output Modules Using AC Field Voltages

Use the diagrams on this page for the following modules:

- G4OAC5
- G4OAC5A
- G4OAC5A5
- G4OAC5MA
- G4OAC5AMA

NOTE: The load can go on either terminal because AC modules are non-polar.

On 4-Position Mounting Racks (G4PB4 and G4PB4R)

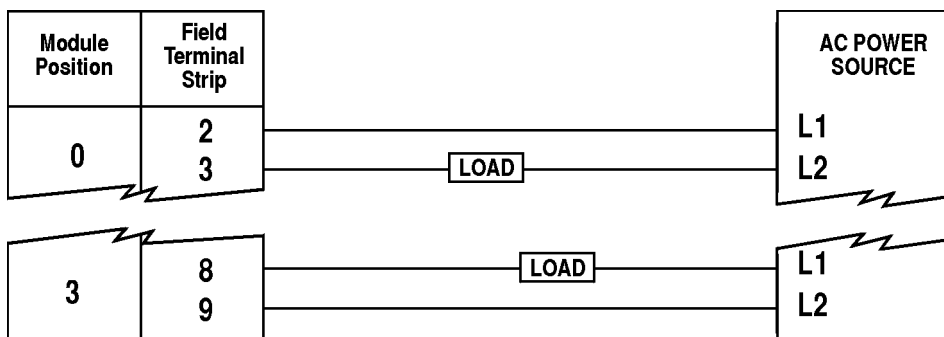

On All Other Mounting Racks

