

UNINTERRUPTIBLE POWER SUPPLY



SPS SOHO+ series



General index

1. Introduction.

1.1. Acknowledgement letter.

1.2. Using this manual.

1.2.1. Conventions and used symbols.

1.2.2. For more information and/or help.

1.2.3. Safety instructions.

1.2.3.1. General safety warnings.

1.2.3.2. To keep in mind.

1.2.3.3. Safety warning regarding batteries.

2. Quality and standard guarantee.

2.1. Declaration of the management.

2.2. Standard.

2.3. Environment.

3. Presentation.

3.1. Views.

3.1.1. Views of the equipment.

3.2. Synoptic with LCD display.

3.3. Nomenclature.

3.4. Structural diagram.

3.5. Operating principle.

4. Installation.

4.1. To be considered in the installation.

4.2. Equipment reception.

4.2.1. Unpacking and contents checking.

4.2.2. Storing.

4.2.3. Location.

4.2.4. Battery charging.

4.3. Communication ports.

4.3.1. Description and features.

4.3.2. Software.

4.4. Connection.

4.4.1. Power Supply connection.

4.4.2. Output connection.

4.4.3. Modem/Phoneline Connection.

5. OPERATION.

5.1. Preliminary controls.

5.2. Start up and shutdown.

5.3. LCD display.

6. Maintenance, warranty and service.

6.1. Basic maintenance guide.

6.2. Battery maintenance.

6.2.1. Notes for installing and replacing the batteries.

6.3. SPS troubleshooting guide.

6.4. Warranty conditions.

6.4.1. Covered product.

6.4.2. Warranty terms.

6.4.3. Out of scope of supply.

6.5. Technical service network.

7. Annexes.

7.1. General technical specifications.

7.2. Glossary.

1. Introduction.

1.1. Acknowledgement letter.

We would like to thank you in advance for the trust you have placed in us by purchasing this product. Read this instruction manual carefully before starting up the equipment and keep it for any possible future consult that can arise.

We remain at your entire disposal for any further information or any query you should wish to make.

Yours sincerely,

SALICRU

- The equipment here described **can cause important physical damages due to wrong handling**. This is why, the installation, maintenance and/or fixing of the here described equipment must be done by our staff or **specifically authorised**.
- According to our policy of constant evolution, **we reserve the right to modify the specifications in part or in whole without forewarning**.
- All **reproduction or third party concession of this manual is prohibited** without the **previous written authorization** of our firm.

1.2. Using this manual.



The target of this manual or publication is to provide information regarding the safety and to give explanations about the procedures for the installation and operating of the equipment. This manual and rest of support documentation has to be read carefully before installing, location change, setting or any handling of any kind, including the start up and shutdown operation.

Keep this document for future consults.









In the next pages, the “**equipment**” and “**S.T.S.**” terms, are referred to the Uninterruptible Power Supply or **SPS** and Service and Technical Support respectively.

1.2.1. Conventions and used symbols.

Some or all the symbols of this section can be used and shown in the equipment and/or in the description of this document. It is advisable to be familiar with them and understand their meaning.

-  «**Danger of electrical discharge**» symbol. Pay special attention to it, both in the indication on the equipment and in the paragraph referred to this user's manual, because it contains features and basic informations for person safety. To not respect these indications can result in serious incidents or even the death due to electrical discharges
-  «**Warning**» symbol. Carefully read the indicated paragraph and take the stated prevention measures, so it contains basic safety instructions for persons. To not respect





such instructions can cause serious incidents. Those indications with “**CAUTION**” symbol content features and basic instructions for safety of the things. To not respect such instructions can damage the goods.

-  «**Precaution**» symbol. Read the paragraph text and take the stated preventive mediums, it contains the basic instructions and features for the equipment safety. To not respect these indications can create material damages on the own equipment, installation or loads.
-  «**Notes of information**» symbol. Additional topics that complement the basic procedures. These instructions are important for the equipment use and its optimum efficiency.
-  «**Main protective earthing terminal**» symbol. Connect the earth cable coming from the installation to this terminal.
-  «**Earth bonding terminal**». Connect the earth cable coming from the load and the external battery cabinet to this terminal.
-  **Preservation of the environment:** The presence of this symbol in the product or in their associated documentation states that, when its useful life is expired, it will not be disposed together with the domestic residuals. In order to avoid possible damages to the environment, separate this product from other residuals and recycle it suitably. The users can contact with their provider or with the pertinent local authorities to be informed on how and where they can take the product to be recycled and/or disposed correctly.
-  Alternating Current A.C..
-  Direct Current D.C..
-  Recycle.

1.2.2. For more information and/or help.

For more information and/or help of your specific unit, contact with our Service and Technical Support (**S.T.S.**).

1.2.3. Safety instructions.

- Check the data of the nameplate are the required by the installation.
-  Never forget that the **SPS is a generator of electrical energy**, therefore the **user has to take precautions about against direct and indirect contacts**. Its energy source, a part from the AC mains, lies on the batteries.
-  **Compliance as regards to “Safety instructions” is mandatory, being the user the legal responsible regarding to its observance and application.** Read them carefully and follow the stated steps in the established order, keep them for future consults that may arise.
-  **If the instructions are not in total or partial and in special referred to the safety, do not carry on with the installation or commissioning tasks**, because there could be a **risk on your safety or on the other/s persons**, being able to make **serious injuries even the death**, also it can **cause damages to the equipment and/or to the loads and installation**.
-  The local electrical regulations and the different restrictions of the client's site, they can invalidate some recommendations included in the manuals. When discrepancies exist, the user has to comply the local regulations.

-  The equipments provided with power cord with plug and outlets, can be connected and used by personnel without any kind of experience.

The equipments with power blocks have **to be installed by qualified personnel** and it can be used by personnel with not specific training, just with only help of this manual.

A person is defined as **qualified**, if it has experience of assembling, commissioning and perfect control operating of the equipment, if he has the requirements to do the job and if has read and understand all the things described in this manual, in particular the safety indications. Such preparation is considered only valid if it is certified by our **S.T.S.**

- Place the equipment the closest to the power supply and loads to be supplied, leaving an easy access if it were needed an urgent disconnection.
- Warning labels should be placed on all primary power switches installed in places away from the equipment to alert the electrical maintenance personnel of the presence of a **SPS** in the circuit

The label will bear the following text or an equivalent one:

Before working in this circuit.

- Isolate the Uninterruptible Power System (**SPS**).
- Check the voltage between all terminals including the protective earth.

 **Risk of voltage feedback from SPS.**

1.2.3.1. General safety warnings.

- All connections and disconnections of the cables from the equipment, including the control ones, will be done with no power supply and the switches on rest, position «O» or «Off».
- Shutdown the equipment completely by switching «Off» the button of the control panel first. Next disconnect the cable from the wall outlet..
-  Pay special attention to the labelling of the equipment that warns about the «Electrical shock hazard». Inside the equipment there are dangerous voltages, never open the enclosure, the access has to be done by qualified staff. In case of maintenance or fault, consult to the closest (**S.T.S.**).

Cross cable sections used to supply the equipment and loads, will be according to the nominal current stated in the nameplate label of the equipment, and respecting the Low Voltage Electro-technical Regulations or standards of the country.

Use approved cables only

-  Protection Earth cable of the **SPS** drives the leakage current of the load devices. An isolated earth cable has to be installed as part of the circuit that supplies the equipment. Cross cable section and its features will be same as the power supply cables, but with green colour with or without the yellow strip.

All outlets of the **SPS** has an earth bonding, duly connected and those equipments with power blocks there is an exclusive terminal for the load earth connection. When an outgoing distribution is done, i.e power strips, it is essential that they have an earth terminal connected to each one of them.

It is essential that the cables that supplies the loads have the earth connection cable.

Check the quality and availability of the earth, it has to be between the defined parameters by the local or national regulations.

- For the smallest devices (the ones connected with the foreseen power cord with plug), the user has to check the wall

outlet corresponds with the type of supplied plug, with earth duly installed and connected to the local protection earth.

-  During the normal **SPS** operation the power cord cable can't be disconnected from wall outlet, because the protection earth of the own **SPS** would be disconnected and also the earth from the loads connected to the output.

For this reason, the general protection earth cable of the building or switchgear panel that supplies the **SPS** will not be disconnected.

- In small equipments (the ones connected with the foreseen power cord with plug), check that the sum of the leakage currents of the **SPS** and connected load/s do not exceed over 3,5mA.
- The installation will have input protections sized to the currents of the equipment and stated in the nameplate label (RCD devices type B and circuit breakers with C characteristic or any other equivalent one).

Overload conditions are considered as a nonpermanent an exceptional operating mode, so these currents will not be kept in mind when sizing the protections.

- Do not overload the **SPS** by connecting loads with inrush consumptions at its output, like laser printers.
- Output protection will be done with a circuit breaker of C characteristic or an equivalent one.

It is recommended to distribute the output power, into four lines as minimum. Each one of them will have a protection circuit breaker sized to the quarter of the nominal power. This kind of outgoing distributions will allow that any fault in any device connected to the equipment, that makes a short-circuit, will affect to the line with the faulty device only. An uninterruptible power supply will be guaranteed to the rest of connected loads, due to the protection tripping of the affected line by the short-circuit only.

- When replacing a fuse, do it for another of the same type, characteristics format and size.
- Under any concept the input power cord will be connected to the output of the equipment, either directly or through other ways.
-  When supplying input voltage to a **SPS** with static bypass, although the inverter is still turned «Off» (deactivated) it doesn't mean that at the output there will not be voltage.

So, to do it, the input switch will have to be turned «Off».

Put warnings of danger and/or emergency switches if the safety Standards require it in your particular installation.

- All power supply electrical cables have to be fixed to the equipments and loads, interfaces, etc..., to unmovable parts and in the way to avoid treads, trips on them or fortuitous pulls.
- CHASSIS or RACK mounted equipments are destined to be installed in a predetermined set to be done by professionals.
 - The installation has to be designed and executed by qualified personnel, who will be the responsible to apply the safety and EMC regulations and standards that controls the particular installations where the product is destined.
 - The equipments assembled in CHASSIS do not have enclosure protection, even the power blocks are unprotected.
 - Some RACK mounted equipments do not have the power blocks protected.
- Never manipulate the equipment with wet hands.

1.2.3.2. To keep in mind.

-  Do not try to dismantle or change any part of the equipment, if this action is not contemplated in this document. Manipulation inside the **SPS** due to any modification, repair or any other cause, can make an electrical discharge of high voltage and it is restricted to **qualified** staff only. Do not open the equipment.

A part from the implicit stated risks, any action that make the modification, internal or external of the equipment or just only the simple intervention inside of itself, which is not stated in this document, **it can expire the warranty**.

- If it is observed that the **SPS** exhausts smoke or toxic gas, shutdown it immediately and disconnect it from the power supply. This kind of fault can cause fire or electrical discharge. Contact with our **(S.T.S.)**.
- In case of an accidental equipment dropping or if the enclosure is damaged, do not start it up under any concept. This kind of fault can cause fire or electrical discharge. Contact with our **(S.T.S.)**.
- Do not cut, manipulate the electrical cables, do not put heavy objects over them too. Any of these actions could cause a short-circuit and make a fire or electrical discharge.

Check that the electrical cables of connection, plugs and outlets are in good conditions.

- When moving an equipment from a cold place to a warm environment and vice versa, it can cause condensation (small water drops) in the external and internal surfaces. Before installing a moved equipment from another place or even packaged, the equipment will be left for a minimum time of two hours in the new location before making any action, with the purpose of adapting it to the new environmental conditions and avoid the possible condensations.





The **SPS** has to be completely dry before starting any installation task.

- Do not store, install or expose the equipment in corrosive, wets, dusty inflammable or explosive environments and never outdoors.
- Avoid to locate, install or store the equipment in a place with direct sunlight or high temperatures. Batteries could be damaged.

In the exceptional case and long exposition to intense heat, batteries can cause filtrations, overheating or explosions, which can cause fires, burn or other injuries. High temperatures can also make deformation in the plastic enclosure.

- The location will be spacious, airy, away from heat sources and easy access.
- Do not obstruct the cooling grids by entering objects through themselves or other orifices.
- Leave as minimum space of 25 cm in the equipment peripheral.
- Do not put materials over the equipment or parts that obstruct the correct visualization of the synoptic.
- Be careful to not wet it, because it is not waterproof. Do not allow entering any kind of liquids in. If accidentally the outside of the machine comes into contact with liquids or salt air, dry it with a soft and absorbent cloth.
- To clean the equipment, wipe over a damp cloth and then dry it. Avoid sprinkling or spillage that could enter through the slots or cooling grids, which may cause fire or electric shock.

Do not clean the equipments with products that could have alcohol, benzene, solvent or other inflammable substances, or they are abrasive, corrosive, liquids or detergent.

- When it is needed to remove the protection cover to access to the terminals, they will have to be put back before starting up the equipment. Otherwise you may incur personal injury or equipment damage.
- Be careful to not lift heavy loads without help, according to the following recommendations:
 - , < 18 kg.
 - , 18 - 32 kg.
 - , 32 - 55 kg.
 - , > 55 kg.
- **SPS** are electronic equipments, so they will be treated as they are:
 - Avoid shocks.
 - Avoid jolting or bouncing of the **SPS**, like those produced by moving the equipment on a hand truck and move on an uneven or wavy surface.
- **SPS** transport will be done packaged inside its original packaging in order to prevent it from shock and impact and by means of the suitable type of packaging (carton box, pallet packaging, ...) and appropriate to its weight.
- Although the physical location of the elements can differ from the illustrations in this manual in some cases, the correct labelling correct the possible doubts and makes easy its comprehension.

1.2.3.3. Safety warning regarding batteries.

-  The manipulation and connection of the batteries shall be done and supervised by **personnel with battery knowledge only**.

Before doing any action, disconnect the batteries. Check that no current is present and there is not dangerous voltage in the DC BUS (capacitors) or in the endpoint of the battery set terminals.

Battery circuit is not isolated from input voltage. Dangerous voltages can be found between the terminals of the battery set and the earth. Check that there is not any voltage at the input before take any action over them.

- When faulty batteries are replaced, the complete battery set has to be replaced, less exceptional cases in new equipments, were due to manufacturing faults it will only be replaced the defective ones.

The replacement will be done by another one of the same type, voltage, capacity, quantity and brand. All of them has to be of the same brand.
- Generally, the used batteries are sealed lead acid of 12V and maintenance free (VRLA).
- Do not reuse the faulty batteries. There could be an explosion or burst any battery with the involved problems and issues that could happen.
- Generally supplied batteries are installed in the same cabinet, case or rack of the equipment. Depending on the power, autonomy or both, they can be supplied separately from the equipment in another cabinet, case or rack, with the interlink cables among them. Do not modify its length.
- In those equipments requested without batteries, their acquisition, installation and connection of themselves will be done by the end-user and **under his responsibility**. Data concerning the batteries as regards to quantity, capacity and voltage, are stated in this battery label stucked beside the nameplate of the equipment. **Respect these data**, battery connection polarity and the supplied circuit diagram **strictly**.

For an optimum and efficient operating, the battery set has to be located as close as possible to the equipment.

-  The battery voltage can involve the risk of electric shock and can produce high short circuit currents. Observe the following preventive measures before manipulating any terminal block identified in the labelling as «Batteries»:
 - Disconnect the corresponding protection elements.
 - When connecting a battery cabinet to the equipment, respect the cable's polarity and colour (red-positive; black-negative) indicated in the manual and in the corresponding labelling.
 - Wear rubber gloves and shoes.
 - Use tools with insulated handles.
 - Take off watches, rings or other metal objects.
 - Do not place metal tools or objects over the batteries.
 - Never manipulate with your hands or through conducting objects, do not short either the battery terminal block of the equipment or the own from the batteries.
- In order to avoid a complete discharge of the batteries and as a safety measure after a long blackout of the commercial mains and when ending the working day, proceed to the load shutdown and then to the equipment too, by following the operating described in this «User's manual».
- When the equipment and/or battery module has a protection through a fuse and it were needed to be replaced, it will always be done by another one with the same dimension, type and size.
- For long periods of disconnection, consider that the equipment has to be connected once a month for 10 hours as minimum, in order to charge the batteries, so the irreversible degradation of itself is avoided. On the other hand, in case of storing an equipment, it will be done in a fresh and dry place, **never outdoors**.
- Never short the battery terminals as it involves a high risk. It involves the detriment of the equipment and batteries.
- Avoid mechanical efforts and impacts.
- Do not open or mutilate the battery. Spilled electrolyte is harmful and toxic to the skin and eyes.
- Do not dispose the batteries in a fire and high temperatures. The batteries may explode.
- In case of contact of the acid with parts of the body, wash immediately with plenty water and call urgently the nearest medical service.
- Batteries involve a serious risk for the health and for the environment. Their disposal should be done according to the existing laws.

2. Quality and standard guarantee.

2.1. Declaration of the management.

Our target is the client's satisfaction, therefore this Management has decided to establish a Quality and Environmental policy, by means of installation a Quality and Environmental Management System that becomes us capable to comply the requirements demanded by the standard **ISO 9001** and **ISO 14001** and by our Clients and concerned parts too.

Likewise, the enterprise Management is committed with the development and improvement of the Quality and Environmental Management System, through:

- The communication to all the company about the importance of satisfaction both in the client's requirements and in the legal and regulations.
- The Quality and Environmental Policy diffusion and the fixation of the Quality and Environment targets.
- To carry out revisions by the Management.
- To provide the needed resources.

2.2. Standard.

The **SOHO+** product is designed, manufactured and commercialized in accordance with the standard **EN ISO 9001** of Quality Management Systems. The **CE** marking shows the conformity to the EEC Directive by means of the application of the following standards:

- **2006/95/EC** Low voltage directive.
- **2004/108/EC** Electromagnetic Compatibility directive (EMC).

In accordance with the specifications of the harmonized standards. Standards as reference:

- **EN-IEC 62040-1**. Uninterruptible power supply (**SPS**). Part 1-1: General and safety requirements for **SPS** used in accessible areas by end users..
- **EN-IEC 60950-1**. IT equipments. Safety. Part 1: General requirements.
- **EN-IEC 62040-2**. Uninterruptible power supply (**SPS**). Part 2: EMC requirements.



The manufacturers responsibility is excluded in the event of any modification or intervention in the product by the customer's side.



This is a product for its use in commercial and industrial applications, so restrictions and additional measures can be needed in the installation to prevent perturbations.



Declaration of conformity CE of the product is at the client disposal under previous request to our headquarters offices.

2.3. Environment.

This product has been designed to respect the environment and has been manufactured in accordance with the standard **ISO 14001**.

Equipment recycling at the end of its useful life:

Our company commits to use the services of authorised societies and according to the regulations, in order to treat the recovered product at the end of its useful life (contact your distributor).

Packaging:

To recycle the packing, follow the legal regulations in force.

Batteries:

The batteries mean a serious danger for health and environment. The disposal of them must be done in accordance with the standards in force.

3. Presentation.

3.1. Views.

3.1.1. Views of the equipment.

Figures 1 to 4 show the illustrations of the equipment according to the case format and depending on the power of the model. Nevertheless and due to the constant evolution of the product, some discrepancies or small contradictions can arise. In front of any doubt, the labelling of the equipment will always prevail.

 Figures regarding its main features or specifications can be checked in the nameplate of the equipment. Keep them in mind for its installation.

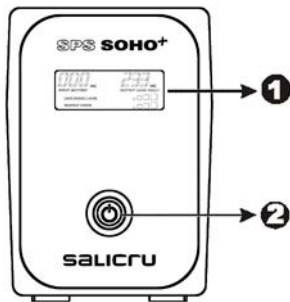

- 1. LCD Back-Light.
- 2. Power «ON/OFF» Switch.

Fig. 1. Front view from SOHO+ 400/600/800 VA.

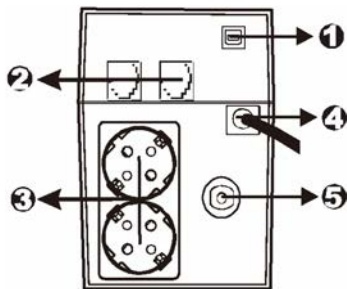

- 1. Communication Port.
- 2. Modem/Phone Line Surge Protection.
- 3. AC Output.
- 4. AC Input.
- 5. Circuit breaker.

Fig. 2. Rear view from SOHO+ 400/600/800 VA.

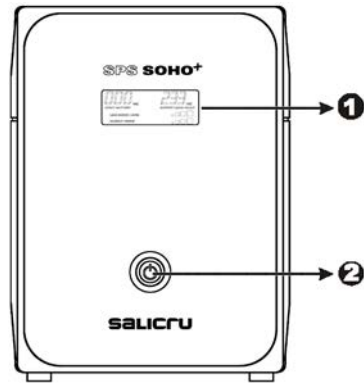

- 1. LCD Back-Light.
- 2. Power «ON/OFF» Switch.

Fig. 3. Front view from SOHO+ 1000/1400/2000 VA.

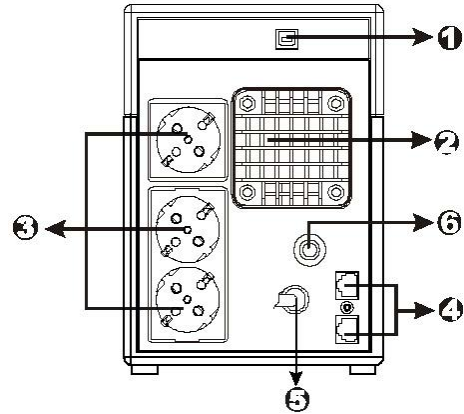

SOHO+ 1000 VA

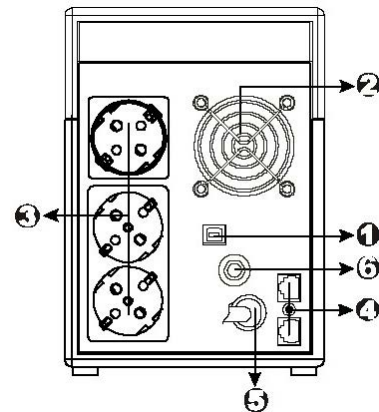

SOHO+ 1400/2000 VA

- 1. Communication Port.
- 2. Cooling Fan.
- 3. AC Output.
- 4. Modem/Phone Line Surge Protection.
- 5. AC Input.
- 6. Breaker.

Fig. 4. Rear view from SOHO+ 1000/1400/2000 VA.

3.2. Synoptic with LCD display.

As it is possible to be observed in the following figure, the equipment has a standart LCD display, where are reflected the input tension and frequency, output voltage and frequency and the fault indicators, load level, battery capacity, line and battery modes.

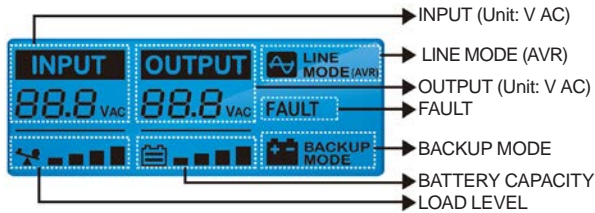
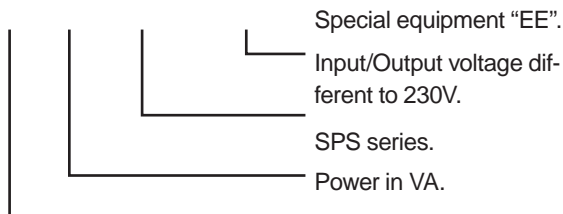

Fig. 5. Synoptic with LCD display

3.3. Nomenclature.

SPS.400.SOHO+ 220V "EE61837-37"



3.4. Structural diagram.

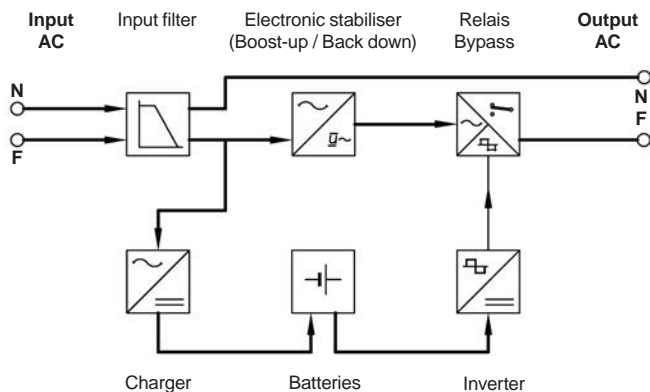

Fig. 6. SPS SOHO+ series block diagram.

3.5. Operating principle.

The SPS is an off-line, interactive Uninterrupted Power Supply System (electronic Boost-up / Back-down stabiliser), controlled by microprocessor. With the unit running, it works as follows:

- With the mains present at between 75 % and 125 % the SPS supplies output voltage through the stabiliser, as well as charging the batteries.
- In the event of mains absent or incorrect (off margins) the inverter supplies pseudo-sinusoidal wave energy from the batteries for a limited time.

- When the mains returns or finds its corresponding margins, the charge is supplied once more from the commercial mains after filtering, and also through the stabiliser.
- Additionally, it has protection against tension tips to the telephone line (Fax, Modem...), through connectors RJ-11/RJ-45.
- The mere fact of the unit being connected to the mains means that the batteries are recharged.
- If the SPS is overloaded in any of its working modes and the load connected to the output is not reduced, the unit will stop supplying output voltage in a few seconds:

Line Mode

110%+20%/-10%; shutdown after 5 minutes and pass to fault mode.

120%+20%/-10%; shutdown immediate and pass to fault mode.



Battery Mode

110%+20%/-10%; shutdown after 5 seconds.

120%+20%/-10%; shutdown immediate.

- The unit has automatic detection of the input frequency, which is activated when it is connected to the mains supply.
- With a software of supervision «Winpower» and a cable of connection in order to use between the equipment and its computer, an intelligent operation is obtained, that provides a perfect protection of the loads.

4. Installation.

- Check the Safety instructions, from section 1.2.3.
- Check that the data in the nameplate are the required by the installation.
- A wrong connection or manoeuvring, can make faults in the **SPS** and/or loads connected to itself. Read carefully the instructions of this manual and follow the stated steps in the established order.
-  The equipments can be installed and used by personnel with no specific training just with the help of this «Manual» only, less those ones that are hard wired, which have to be installed by qualified personnel.
-  All connections of the equipment including the control (interface, remote panel, ...), will be done with the switches at rest and no voltage present (**SPS** power supply switch to «Off»).
-  Never forget that the **SPS** is an electrical energy generator, so the user has to take the needed cautions against direct and indirect contacts.
- Connection to any other type of receptacle other than a two-pole, three-wire grounding receptacle may result in shock hazard as well as violate local electrical codes.
- In the event of an emergency, turn the power switch to the «off» position and disconnect the power cord from the AC power supply to properly disable the **SPS**.
- This unit intended for installation in a controlled environment (temperature controlled, indoor area free of conductive contaminants). Avoid installing the **SPS** in locations where there is standing or running water, or excessive humidity.
- Do not attach a power strip or surge suppressor to the **SPS**.
- Do not attach non-computer-related items, such as medical equipment, life-support equipment, microwave ovens, or vacuum cleaners to **SPS**.

4.1. To be considered in the installation.

- All the equipments have power cord with schuko plug to be connected to the AC mains.
In the same way, 2 or 3 schuko outlets are supplied depending on the model, for its connection with the loads (output).
- Cross cable section of the input and output lines, will be calculated from the currents stated in the nameplate of each equipment, and respecting the Local and/or National Low Voltage Electrotechnical Regulations.
- Protections of the switchgear panel, will have the following features:
 - For input line, type B for RCD devices and C characteristic for circuit breakers.
 - For the output (load feeding), C characteristic for circuit breaker.Regarding the size, they will be as minimum to the currents stated in the nameplate of each **SPS**.
- In the nameplate of the equipment there are only printed the nominal currents as it is stated in the safety standard EN-IEC 62040-1. To calculate the input current, the power factor and the efficiency of the equipment have been considered.
Overload conditions are considered as nonpermanent and exceptional operating mode.

4.2. Equipment reception.

4.2.1. Unpacking and contents checking.

- On receiving the unit, make sure that it has not been damaged in any way during transport, so it could be better to unpack it to make a visual inspection and to check that the features of itself corresponds to those specified in the order (See nameplate stucked to the packing). If it is damaged, make all suitable claims to your supplier or, short of this, to our firm, by mentioning the serial number of the equipment and the references of the delivery invoice.
- Having completed the reception, it is best to pack the equipment into its original packing until it is put into service in order to protect it against possible mechanical impacts, dust, dirt, etc. In any case we recommend to keep the packing.
- The packing is made of recycable materials, therefore if they are to be disposed, it must be done in accordance with the effective laws.

4.2.2. Storing.

- The unit must be stored in a dry and well-ventilated place and protected from the rain, water projections or chemical agents. It is best to keep the unit in their original packing as this packing has been specifically designed to ensure maximum protection during transport and storage.
-  The **SPS** includes sealed lead-calcium batteries, and they should not be stored for more than 4 months without recharging the batteries for 6 hours minimum. This means that the unit shall be connected to the commercial mains and started up. Once the batteries are recharged return the equipment to its original packing.
Do not store the devices where the ambient temperature exceeds 40° C or falls below -20° C, otherwise it might deteriorate the electrical characteristics of the batteries.

4.2.3. Location.

Install the **SPS** unit in any protected environment that provides adequate airflow around the unit, and is free from excessive dust, corrosive fumes and conductive contaminants. Do not operate your **SPS** in an environment where the ambient temperature or humidity is high. On the other hand, place the **SPS** unit away from monitor at least 20cm to avoid interference.

4.2.4. Battery charging.

This unit is shipped from the factory with its internal battery fully charged. however, some energy may be lost during shipping so the battery should be recharged before using it. Plug the unit into an appropriate power supply and allow the **SPS** to charge fully by leaving it plugged in for 8 hours.(models 400/600/800 VA) and for 10 hours (models 1000/1400/2000 VA).

4.3. Communication ports.

4.3.1. Description and features.

New series SOHO+ incorporates a port USB with which to communicate with the outside.

4.3.2. Software.

• Free software download - WinPower.

WinPower is a **SPS** monitoring software, which makes a user-friendly interface of monitoring and management. This software supplies an auto Shutdown for a system based on several PCs in case of an electrical blackout. With this software, the end-users can monitor and manage any **SPS** in the same IT network, through the RS232 or USB communication port, never mind the distance between them.

• Installation procedure:

- Go to website:
<http://support.salicru.com>
- Choose the operating platform that you need and follow the instructions described in the web site to download the software.
- When downloading the needed files from Internet, enter the following licence to install the software:
511C1-01220-0100-478DF2A .

When the computer is rebooted, WinPower software will be shown as an icon with plug shape and green colour in the system tray, near the clock.

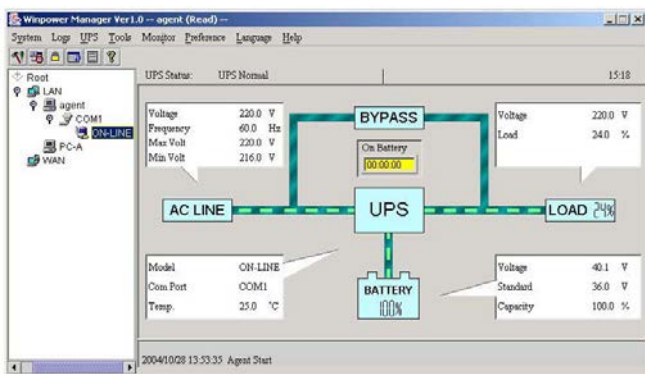

Fig. 7. Main screen of the monitoring software.

4.4. Connection.

4.4.1. Power Supply connection.

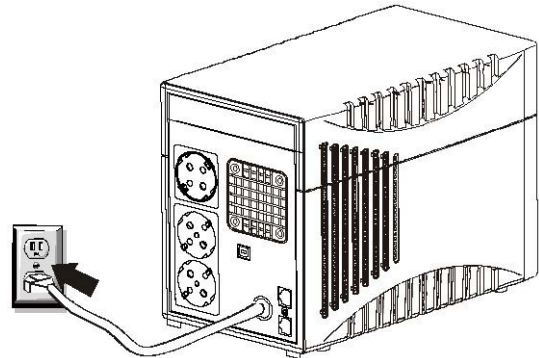

Fig. 8. Power supply connection.

4.4.2. Output connection.

Connect one computer-related device into each of the power receptacles supplied on the back of the **SPS** (maximum of two or three depending on model).

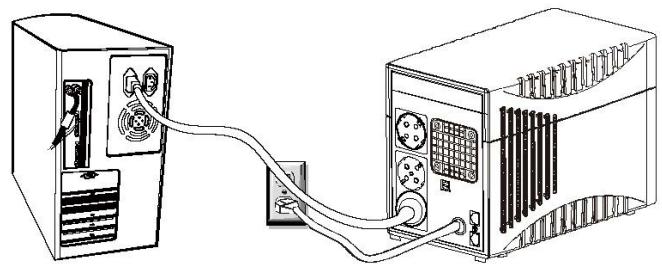

Fig. 9. Output connection.

4.4.3. Modem/Phoneline Connection.

Plug incoming internet line into the «In» socket at the back of the **SPS**. Use one more Internet line cable and plug one end of the Internet line cable to the «Out» socket at the back of the **SPS**. Plug the other end to the modem input socket as shown.

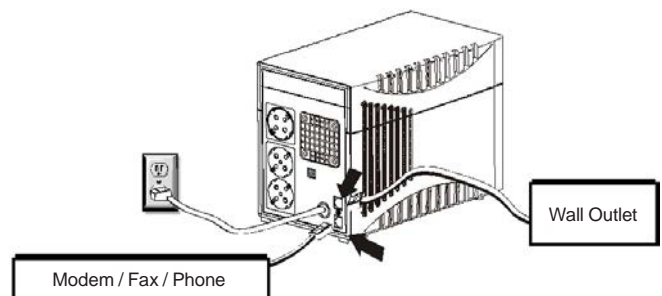



Fig. 10. Modem/Phoneline Connection.

5. OPERATION.

5.1. Preliminary controls.

- Make sure that all connections have been done properly, and respecting the labelling of the equipment and the instructions of chapter 4.
- Check that the power supply is correct.
- Check that the **SPS** is Off (shutdown).
- Make sure that all loads are shutdown «Off».
-  Loads can be connected after the **SPS** start up and one by one. Before shutdown the **SPS**, check that all loads are shutdown (Off).
- Check that the thermal protection of the equipment is not tripped.
- Turn "ON" the protection of the distribution panel.

5.2. Start up and shutdown.

To turn on the **SPS** unit, press the power switch lightly. To turn off the **SPS** unit, press the power switch again (When switch ON the LED lighting.).



Fig. 11. Start up and shutdown.

5.3. LCD display.

The LED will always turns on when **SPS** works, including in off charging mode and fault mode.

When LCD start to work, it will display all information for 3s:

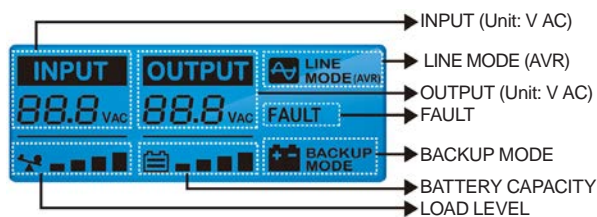

Fig. 12. LCD display.

- When in normal mode, it will display as below.

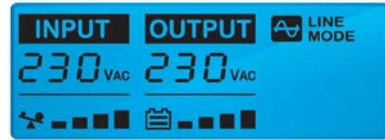

Fig. 13. Screen normal mode.

- When in AVR mode, it will display as below. And the mark  will flicker every 1 second.

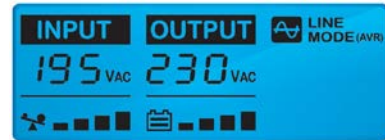



Fig. 14. Screen AVR mode.

- When in battery mode, it will  display as below. And the mark will flicker every 1 second.

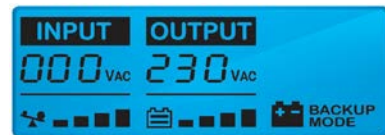

Fig. 15. Screen battery mode.

Note: If I/P-V < 40 V, input voltage will display "000".

- When in off charging mode, it will display as below.

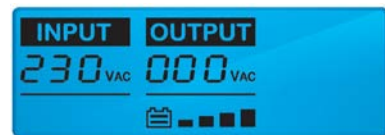

Fig. 16. Screen charging mode.

Note: The output voltage always is displayed as "000" in off charging mode.

- When in fault mode, it will display as below.



Fig. 17. Screen fault mode.

- Load level definition:



Load level	Battery bar indication
	0.. 25 %
	25.. 50 %
	50.. 75 %
	75.. 100 %

Table 1. Load level.

- Battery capacity definition:





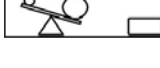
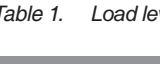

Battery level	Battery bar indication
	Battery voltage ≤ 11 V
	11 V \leq Battery voltage $\leq 11,5$ V
	$11,5$ V \leq Battery voltage $\leq 12,5$ V
	Battery voltage $\geq 12,5$ V

Table 2. Battery level.

- When over load, the mark  will flicker every 1 second.
- When battery low, the mark  will flicker every 1 second.

6. Maintenance, warranty and service.

6.1. Basic maintenance guide.

The main guidelines for a correct maintenance are similar to the ones that are applying our Service and Technical Support in the Preventive maintenance modality (see section 6.5).

6.2. Battery maintenance.

- Pay attention to the safety instructions regarding battery and the stated in section 1.2.3.3.
- The **SPS** from **SOHO+** series only requires a minimum maintenance. The used battery in the standard models is lead acid, sealed, VRLA and maintenance free. These models require a minimum of reparations. The only requirement is to charge the **SPS** regularly, in order to prolong the battery lifetime. Meanwhile, it is connected to the power supply, never mind if the **SPS** is ON or OFF, it will keep the batteries charged and will give protection against overcharging and undercharging.
- The **SPS** has to be charged once, every 4 or 6 months if it has not been used for long time.
- In hot areas, battery has to be charged every 2 months. The charging time has to be 12 hours as minimum.
- Under normal conditions, the battery lifetime is from 3 to 5 years 25° C. In case that the battery was not in good conditions, it has to be replaced before. This replacement has to be done by qualified staff.
- Always replace them with the same quantity and type.
- Do not replace one battery only. All batteries have to be replaced at the same time and following the instructions of the manufacturer.
- Usually, the batteries should be charged and discharged every 4 or 6 months. The charging would be started after shutdown the **SPS** due to a low battery (discharging). Charging time for standard **SPS** should be 12 hours as minimum.

6.2.1. Notes for installing and replacing the batteries.

- If it is needed to replace the connection of any wire, purchase original parts through authorised distributors or service centres in order to avoid overheating and sparks with fire risk because the size is not enough.
- Do not short the + and - poles of the batteries, there is risk of fire or electrocution.
- Be sure that there is no voltage before touching the batteries. Battery circuit is not isolated from the input. Hazardous voltages can be found between the battery and earth terminals
- Although the input circuit breaker the switchgear panel is turned off, the internal parts of the **SPS** are still connected to the batteries, so there are hazardous voltages inside.

Therefore, before doing any reparation or maintenance task, the internal battery fuses have to be removed and/or the interlink connections between them and the **SPS**.

- Batteries have hazardous voltages. The battery maintenance and replacement have to be done by qualified personnel and familiarised with them. Nobody else can manipulate them.

6.3. SPS troubleshooting guide.

If the **SPS** doesn't work properly, check the information given by the LCD of the control panel. Try to solve the problem by means of the established steps in the table 3. In case the problem persists, consult with our Service and Technical Support **S.T.S.**

When it is needed to contact with our Service and Technical Support **S.T.S.**, provide the following information:

- **SPS** model and serial number.
- Date when the problem occurred.
- Complete description of the problem, including the information given by the LCD panel and the status of the alarms.
- Power supply condition, type of load and the level connected to the **SPS**, ambient temperature, cooling conditions.
- Other informations that you may think that they are important.

Symptom	Possible Cause	Remedy
LCD display is not illuminated	1. Unloaded battery.	1. Charge battery up to 8 hours.
	2. Battery defect.	2. Replace with the same type of battery.
	3. When the Input cord isn't electrified and Power switch is not pressed.	3. Press the power switch again or test the Input cord.
Alarm buzzer beeps continuously when AC supply is normal.	Overload of the UPS.	Verify that the load matches the UPS capability specified in the specs.
When power failure, back-up time is shorten.	1. Overload of the UPS.	1. Remove some noncritical load.
	2. Battery voltage is too low.	2. Charge battery 8 hours or more.
	3. Battery defect due to high temperature operation environment, or improper operation to battery.	3. Replace with the same type of battery.
Communication lost between UPS and computer.	1. Software is not installed well.	1. Check the setting of the software .
	2. Cable is not properly connected.	2. Check the USB cable is firmly connected to the computer and confirm the setting again.
Mains normal but LCD display Battery mode.	1. Circuit breaker tripped.	1. Reset the circuit breaker.
	2. Power cord is loose.	2. Reconnect the power cord properly.

Table 3. SPS troubleshooting guide.

6.4. Warranty conditions.

The limited warranty only applies to those products that you acquire for commercial or industrial use in the normal development of your business.

6.4.1. Covered product.

SPS SOHO+ series.

6.4.2. Warranty terms.

See product conditions as in Website.

6.4.3. Out of scope of supply.

Our company is not forced by the warranty if it appreciates that the defect in the product doesn't exist or it was caused by a wrong use, negligence, installation and/or inadequate testing, tentative of repairing or not authorized modification, or any other cause beyond the foreseen use, or by accident, fire, lightnings or other dangers. Neither it will cover, in any case, compensations for damages or injuries.

6.5. Technical service network.

Coverage, both national and international, from our Service and Technical Support (**S.T.S.**), can be found in our Website.

7. Annexes.

7.1. General technical specifications.

MODEL		SPS.400.SOHO+	SPS.600.SOHO+	SPS.800.SOHO+	SPS.1000.SOHO+	SPS.1400.SOHO+	SPS.2000.SOHO+
CAPACITY	VA / W	400 / 240	600 / 360	800 / 480	1000 / 600	1400 / 840	2000 / 1200
INPUT	Voltage	220, 230, 240 VAC				230, 240 VAC	
	Voltage Range	162-290 VAC				166-290 VAC	
	Frequency	50 Hz / 60 Hz					
OUTPUT	Voltage	220, 230, 240 VAC				230, 240 VAC	
	Voltage regulation (Battery Mode)	± 10 %				± 5 % at load < 50 %	
	Frequency	50 Hz / 60 Hz					
	Frequency regulation (Battery Mode)	± 1 Hz					
	Output Waveform	Pseudo Sine-wave					
BATTERY	Battery Type and No	12 V / 4.5 Ah x 1pcs	12 V / 28 W x 1 pcs	12 V / 34 W x 1 pcs	12 V / 7 Ah x 2 pcs	12 V / 9 Ah x 2 pcs	
	Back up Time ⁽¹⁾	8 minutes			10 minutes		6 minutes
	Recharge Time	8 Hours to 90 % after complete discharge			10 Hours to 90 %		6 Hours to 90%
TRANSFER TIME	Typical	2 - 6 ms			4 - 6 ms		4 - 8 ms
INDICATOR	LCD Display	The LCD will always turn on when UPS work, including in off charging mode and fault mode					
AUDIBLE ALARM	Battery Mode	Sounding every 10 seconds					
	Battery Low	Sounding every 1 second					
	Overload	Sounding every 0,5 seconds					
	Battery replace	Sounding every 2 seconds					
	Fault	Continuously sounding					
	Buck / Boost with > 70 % SPS load	Sounding every 0.5 seconds after 25 min. and fault after 30 min.				NA	
PROTECTION	Full protection	Discharge, Overcharge, Short Circuit and Overload Protection					
PHYSICAL	Dimension (DxWxD) (mm.)	330 x 100 x 140				399 x 145 x 205	
	Net Weight (Kg.)	4.5	5	6.5	9	9.5	10
ENVIRONMENT	Operating	0 - 40 °C, 0 - 90 % Relative Humidity (non-condensing)					
	Noise Level	Less than 40 dB				Less than 45 dB	
INTERFACE	USB	For Windows family & MAC					

(1) Minimum at 50% load.

Table 4. General technical specifications.

7.2. Glossary.

- **Electromagnetic Compatibility.**- Branch of the electronic and telecommunication technology that is in charge of the interferences between the electric and electronic equipments. It is defined (in accordance with the international standard collected on the Technical file of the International Electrotechnical Commission 61000-1-1) as «the capacity of any device, equipment or system to operate in suitable way in its electromagnetic environment without making electromagnetic perturbations over anything in that environment».
- **VA.**- Voltampere is the unit of the apparent power in alter-

nating current. In the direct current is almost equal to the real power but in the alternating current it can be different depending on the power factor. The voltamperes are arithmetic product of the multiplication between the voltage and current.

- **LCD.-** LCD are the English acronyms of Liquid Crystal Display.
- **Serial port.-** A serial port is a communication interface among computers and peripherals, where the data is transmitted bit by bit and sending one bit only every time, meanwhile the parallel port sends several bits at the same time.
- **Modem.-** It is the acronym of the words modulator/demodulator. Modulador sends a constant analogical signal called holder. Generally, it is a simple sinewave. When digital data needs to be sent, it is modified any characteristic of the holder signal, therefore it is stating if it is sending a «zero» or «one».
- **Circuit breaker.-** A circuit breaker is based in the operation of two effects made by the electrical current circulation in a circuit, the magnetic and thermal (Joule effect). So, the device has two parts, an electromagnetic and a **b i** - metal plate, connected in series and the current is circulating through them to the load.
- **LAN.-** LAN is the acronym of Local Area Network or just Local Network. A local network interconnects several computers and peripherals. Its extension is physically limited to one building or to one surrounding of a few kilometers. Its most extended application is the interconnection of personal computers and workstations in offices, factories, etc; to share resources and to exchange data and applications.
- **AVR.-** It is the acronym of Automatic Voltage Regulator, and it is a device ready to stabilize the output electrical voltage to preset values (accuracy) in front of fluctuations at its input (input range).
- **Autonomy.-** It is the time, previously specified, during which the **SPS** is able to supply a fixed voltage and frequency and a certain current to the loads connected to its output.
- **Transfer time.-** It is the time that lapses in a Line Interactive or Off-Line **SPS** when the input mains faults and the inverter starts up and supplies output voltage. Usually it is around a few milliseconds.



A series of horizontal dotted lines for writing, starting from the top left and extending across the page.

SALICRU

Avda. de la Serra, 100
08460 Palautordera
BARCELONA
Tel. +34 93 848 24 00
902 48 24 00 (Only Spain)
Fax. +34 94 848 11 51
salicru@salicru.com
Tel. (S.T.S.) +34 93 848 24 00
902 48 24 01 (Only Spain)
Fax. (S.T.S.) +34 93 848 22 05
sst@salicru.com
SALICRU.COM

BRANCHES AND SERVICES AND TECHNICAL SUPPORT (S.T.S.)

BARCELONA	PALMA DE MALLORCA
BILBAO	PAMPLONA
GIJÓN	SAN SEBASTIÁN
LA CORUÑA	SEVILLA
LAS PALMAS DE G. CANARIA	VALENCIA
MADRID	VALLADOLID
MÁLAGA	ZARAGOZA
MURCIA	

SUBSIDIARIES

CHINA	MÉXICO
FRANCIA	PORTUGAL
HUNGRÍA	REINO UNIDO
MARRUECOS	SINGAPUR

REST OF WORLD

ALEMANIA	JORDANIA
ARABIA SAUDÍ	KUWAIT
ARGELIA	MALASIA
ARGENTINA	PERÚ
BÉLGICA	POLONIA
BRASIL	REPÚBLICA CHECA
CHILE	RUSIA
COLOMBIA	SUECIA
CUBA	SUIZA
DINAMARCA	TAILANDIA
ECUADOR	TÚNEZ
EGIPTO	UEA
FILIPINAS	URUGUAY
HOLANDA	VENEZUELA
INDONESIA	VIETNAM
IRLANDA	

Product Range

Uninterruptible Power Supply (UPS)
Lighting Flow Dimmer-Stabilizers (ILUEST)
Switch Mode Power Supplies
Static Inverters
Photovoltaic Inverters
Voltage Stabilisers and Power Line Conditioners

