

IEC Appliance Inlet C8 polarized, Screw-on Mounting, Front Side, Solder, Quick Connect or PCB Terminal



C8 polarized



70 °C



### Description

- Panel Mount
- Screw-on mounting, from front side
- Appliance Inlet, Pin temperature 70 °C, Protection class II
- Solder, Quick Connect or PCB Terminal

### Approvals

- VDE Certificate Number: 40034368
- UL File Number: E96454

### Weblinks

[pdf-datasheet](#), [html-datasheet](#), [General Product Information](#), [Approvals](#), [CE declaration of conformity](#), [RoHS](#), [CHINA-RoHS](#), [REACH](#), [Mating Connectors](#), [e-Shop](#), [SCHURTER-Stock-Check](#), [Distributor-Stock-Check](#), [CAD-Drawings](#), [Accessories](#), [Detailed request for product](#)

### Technical Data

Ratings IEC	2.5 A / 250 VAC; 50 Hz
Ratings UL/CSA	2.5 A / 250 VAC; 60 Hz 7 A / 125 VAC; 60 Hz
Dielectric Strength	> 3 kVAC between L-N > 1.5 kVAC between L/N-PE (1 min/50 Hz)
Allowable Operation Temp.	-25 °C to 70 °C
Degree of Protection	from front side IP 20 acc. to IEC 60529
Protection Class	Suitable for appliances with protection class II acc. to IEC 61140
Material: Housing	PA6, black / grey / white, UL 94V-0

Appliance Inlet	C8p acc. to IEC 60320-1 UL 498, CSA C22.2 no. 42 (for cold conditions) pin-temperature 70 °C, 2.5 A, Protection Class II
-----------------	---

**Dimensions**

Solder terminals for PCB

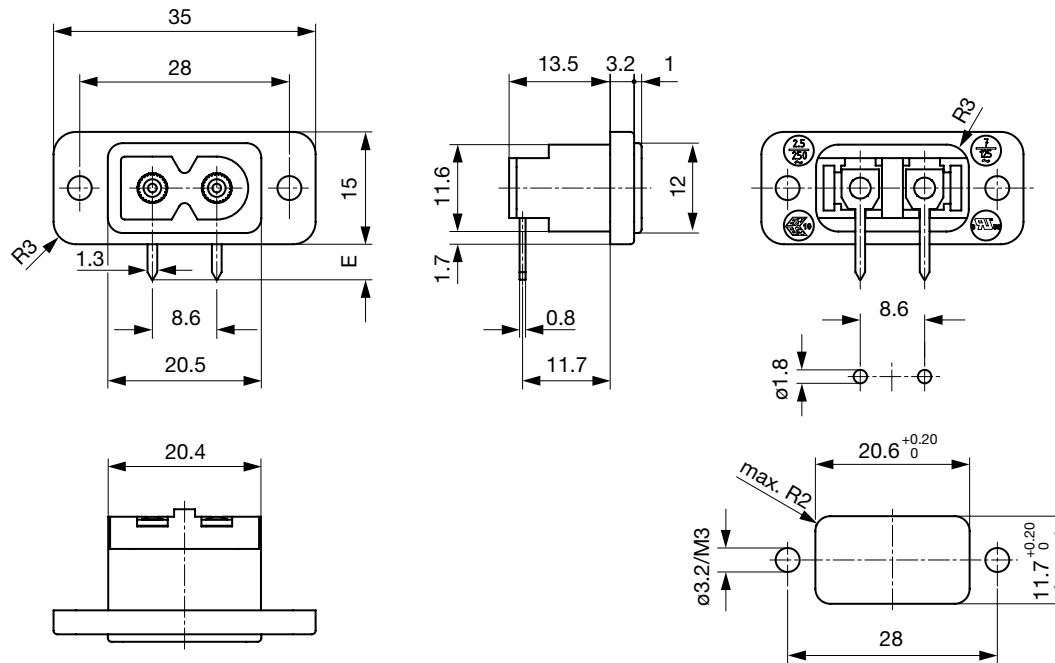

- E: PCB terminal standard: 4.8 mm
- E: PCB terminal short: 3.2 mm
- E: PCB terminal long: 5.9 mm

**Terminals orientation A**

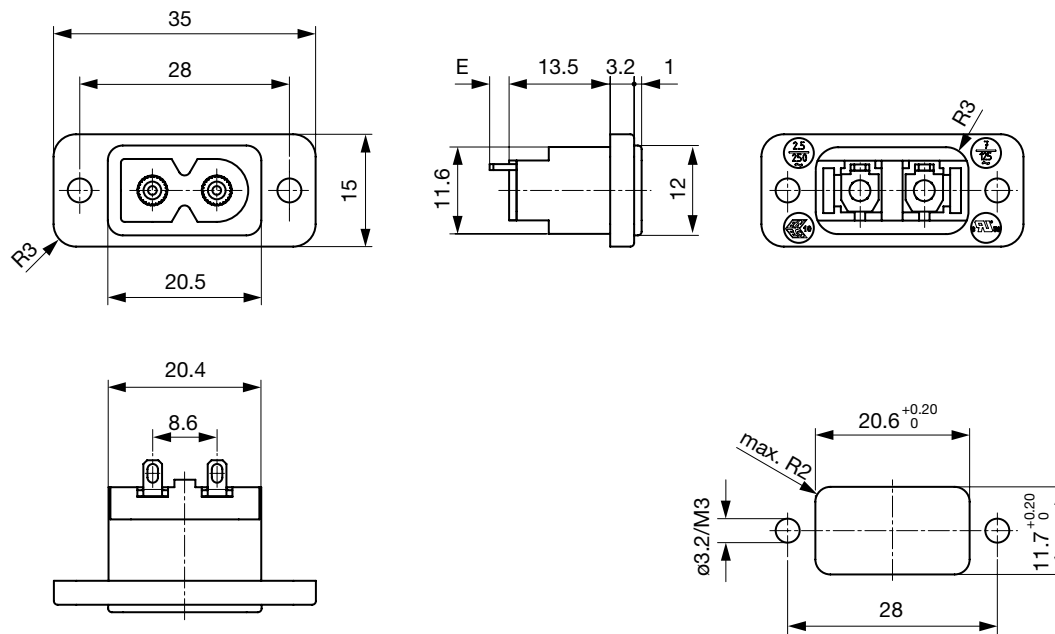

- E: Solder terminals short: 3.6 mm (L=4.8 mm)
- E: Solder terminals long: 7.3 mm (L=8.5 mm)
- E: Quick connect terminals 2.8x0.8 mm: 9.6 mm

Terminals orientation B

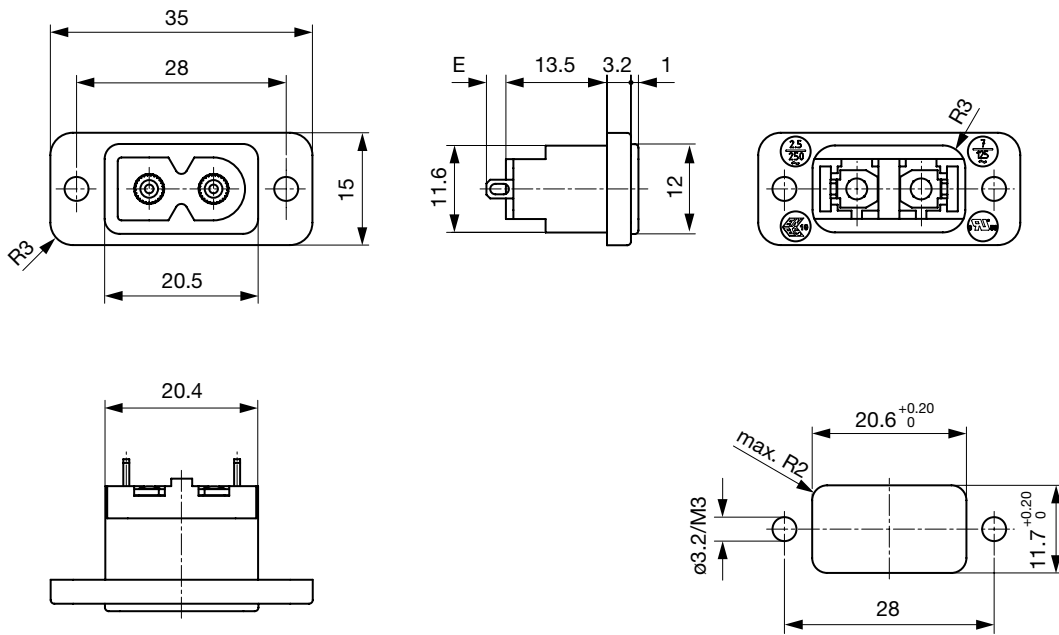

- E: Solder terminals short: 3.6 mm (L=4.8 mm)
- E: Solder terminals long: 7.3 mm (L=8.5 mm)
- E: Quick connect terminals 2.8x0.8 mm: 9.6 mm

Config. Code

2577 - H - A B C 0 - D - E G F

The characters are placeholders for the correspondingly keys of selections from the key tables.

2577 - H - A B C 0 - D - E G F = Type

Type	Configuration key
protection class II	X

2577 - H - A B C 0 - D - E G F = Terminals

Terminal L	Configuration key
short solder terminal (L = 4.8 mm)	2
long solder terminal (L = 8.5 mm)	3
PCB-terminal standard (additional solder terminal)	4
PCB-terminal short (additional solder terminal)	5
PCB-terminal long (additional solder terminal)	6

Terminal L

Blade terminal (2.8 x 0.8 mm)



7

PCB-terminal (standard)



A

PCB-terminal (short)



B

PCB-terminal (long)



C

2577 - H - A B C 0 - D - E G F = Terminals

Terminal N

short solder terminal (L = 4.8 mm)

2

long solder terminal (L = 8.5 mm)

3

PCB-terminal standard (additional solder terminal)

4

PCB-terminal short (additional solder terminal)

5

PCB-terminal long (additional solder terminal)

6

Blade terminal (2.8 x 0.8 mm)

7

Symbols similar as in table A

Terminal N	Configuration key
PCB-terminal (standard)	A
PCB-terminal (short)	B
PCB-terminal (long)	C

Symbols similar as in table A

2577 - H - A B C 0 - D - E G F = Terminals

Terminal Ground	Configuration key
without terminal	0

Symbols similar as in table A

2577 - H - A B C 0 - D - E G F = Color

Color	Configuration key
Black	A
Grey	B
White	D

2577 - H - A B C 0 - D - E G F = Style

Style	Configuration key
flange with countersunk holes	1
flange with through holes	2

2577 - H - A B C 0 - D - E G F = Mass S

Mass "s"	Configuration key
00	

The dimension "S" is displayed in ( $\frac{1}{10}$  mm). This information is also valid for the order code

2577 - H - A B C 0 - D - E G F = Orientation of Terminals

Orientation of Terminals	Configuration key
horizontal	A
vertical	B

All Variants

Config. Code	Description	Order Number
2577-X-2200-A-200A	2577, IEC Appliance Inlet C8p, 70°C, , version: protection class II, L: short solder terminal (L = 4.8 mm), N: short solder terminal (L = 4.8 mm), ground: without terminal, color: Black, design: flange with through holes, dimension S: 00	6160.0101
2577-X-3300-A-200A	2577, IEC Appliance Inlet C8p, 70°C, , version: protection class II, L: long solder terminal (L = 8.5 mm), N: long solder terminal (L = 8.5 mm), ground: without terminal, color: Black, design: flange with through holes, dimension S: 00	6160.0102
2577-X-4400-A-200A	2577, IEC Appliance Inlet C8p, 70°C, , version: protection class II, L: PCB-terminal standard (additional solder terminal), N: PCB-terminal standard (additional solder terminal), ground: without terminal, color: Black, design: flange with through holes, dimension S: 00	6160.0103
2577-X-BB00-A-200A	2577, IEC Appliance Inlet C8p, 70°C, , version: protection class II, L: PCB-terminal (short), N: PCB-terminal (short), ground: without terminal, color: Black, design: flange with through holes, dimension S: 00	6160.0104
2577-X-CC00-A-200A	2577, IEC Appliance Inlet C8p, 70°C, , version: protection class II, L: PCB-terminal (long), N: PCB-terminal (long), ground: without terminal, color: Black, design: flange with through holes, dimension S: 00	6160.0105
2577-X-7700-A-200A	2577, IEC Appliance Inlet C8p, 70°C, , version: protection class II, L: Blade terminal (2.8 x 0.8 mm), N: Blade terminal (2.8 x 0.8 mm), ground: without terminal, color: Black, design: flange with through holes, dimension S: 00	6160.0106
2577-X-2200-A-200B	2577, IEC Appliance Inlet C8p, 70°C, , version: protection class II, L: short solder terminal (L = 4.8 mm), N: short solder terminal (L = 4.8 mm), ground: without terminal, color: Black, design: flange with through holes, dimension S: 00	6160.0143

The listed variants should be available from stock Other versions on request [www.schurter.com/contact](http://www.schurter.com/contact)

Most Popular.

Availability for all products can be searched real-time: <http://www.schurter.com/Stock-Check/Stock-Check-SCHURTER>

Packaging unit 100 Pcs

Mating Outlets/Connectors

Category / Description



Power Supply Cord Overview complete

Cord Sets 2.5 A, North America, Black, 2.5 m, SVT 2x18AWG, IEC C7p, 002500 mm, cord end:

6052.0047

Power Supply Cord further types to 2577