

Assembly Manual for V1.0

MeArm.io

Manual Revision 1.4 September 2015

This assembly manual is based on a work by Scott Pierce ([www.spiercetechnology.com](http://www.spiercetechnology.com))

# Building the MeArm

Please Note: The MeArm relies on self tapping screws, do not over tighten or you could strip the hole or break the part.

Do not attempt to force parts together as excessive force can break them.

Please contact us on our forums at [forum.mearm.io](http://forum.mearm.io) if you encounter any problems with your build.





## Parts

Building the MeArm Requires the following fasteners. These profiles are actual size (if printed A5 sized paper).

The acrylic parts list is shown for reference. Small differences may occur as the product is improved over time.

Construction requires a small cross head screwdriver and 2.5mm hex key, which is supplied.

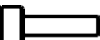
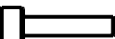
Additional screws for the servo arms are included in the servo packs.

- 10x – M3 Nut 
- 6x – M3 x 6 
- 15x – M3 x 8 
- 3x – M3 x 10 
- 8x – M3 x 12 
- 4x – M3 x 20 
- 4x – Rubber Foot 

# Acrylic Parts

Comprising 24 large parts and 12 smaller parts, bagged separately

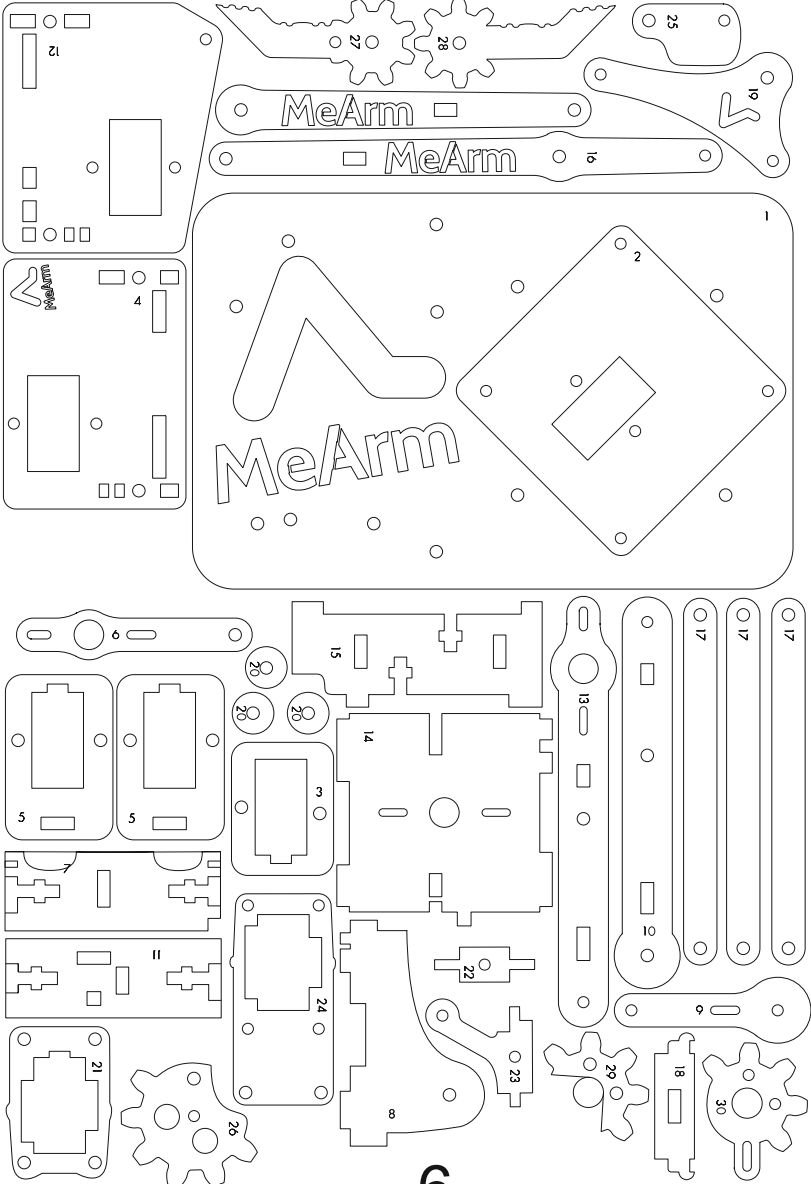

Before fixing together align screw holes on Base Plate, Pivot Servo Plate and Base Servo Collar for later reference. If the Base Servo Collar faces the wrong way then flip the Pivot Servo Plate.

PARTS LIST			
ITEM	PART NAME	QTY	PART NUMBER
1	Base Plate	1	1
2	M3 x 20mm Screw	4	
3	Rubber Foot	4	
4	Pivot Servo Plate	1	2
5	Servo Motor	1	
6	Base Servo Collar	1	3
7	M3 x 8mm Screw	2	
8	M3 Nut	4	

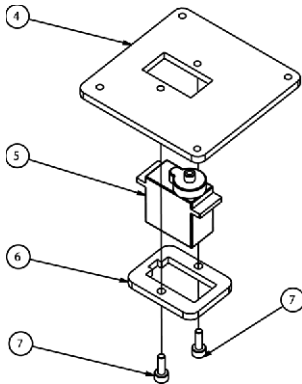

- Step 1. Insert MIDDLE Servo Motor into top side of Servo Collar
- Step 2. Insert Servo Motor into bottom side of Pivot Servo Plate
- Step 3. Insert (2x) M3 x 8mm Screws through bottom of Servo Collar and fix to Pivot Servo Plate

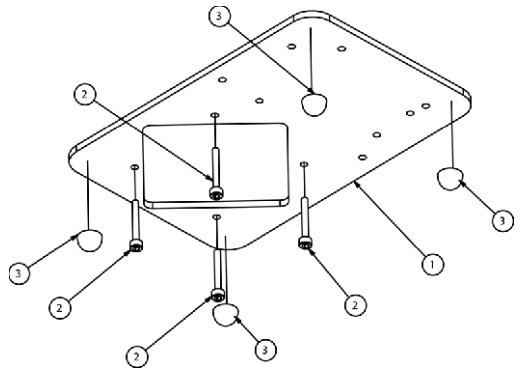

- Step 4. Attach Rubber Feet to underside of Base Plate
- Step 5. Insert (4) 20mm Screw though from underside of Base Plate

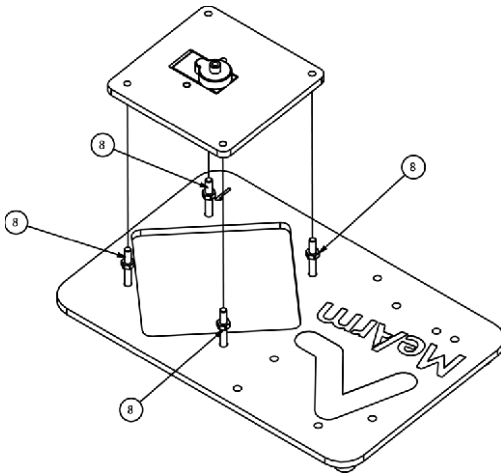

- Step 6. Thread (1x) Nut half way down each of the (4x) 20mm Screws.
- Step 7. Screw each of the 20mm Screws into the mating holes on the Pivot Servo Plate until the end of the screw is flush with the top of the plate

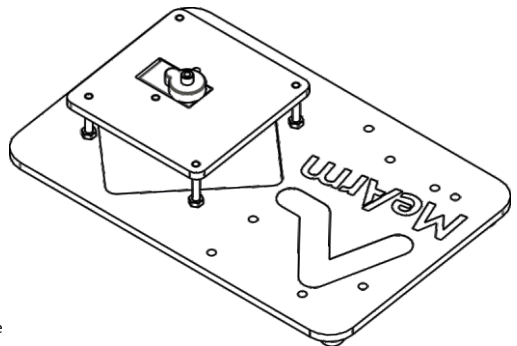

- Step 8. Tighten the Nuts rest of the way down (finger tight is fine).

ITEM	PART NAME	QTY	PART NUMBER
1	Left Arm Servo Plate	1	4
2	M3 x 8mm Screw	2	
3	Servo Collar	1	5
4	9 Gram Servo	1	
5	Long Servo Arm	1	6
6	Servo Double Arm	1	
7	Servo Mount Screw	2	
8	Servo Screw	1	

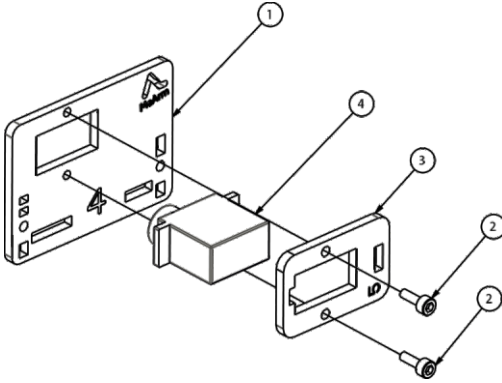

Step 10. Slide Servo Collar over the bottom end of the Servo and insert cable through rectangular hole

Step 11. Insert (2) M3 x 8mm Screws into the Servo Collar and attach to Left Arm Servo Plate

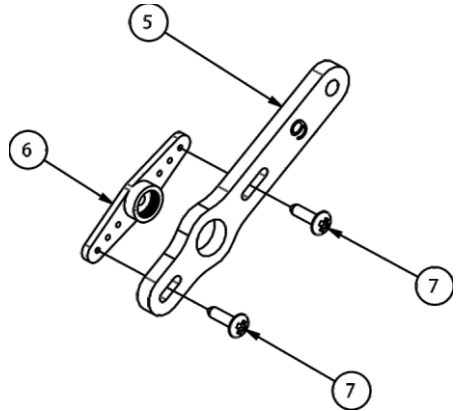

Step 12. Attach the Servo Arm to the Long Servo Arm Extension using the sharp screws in the servo pack. These will self tap with a little pressure.

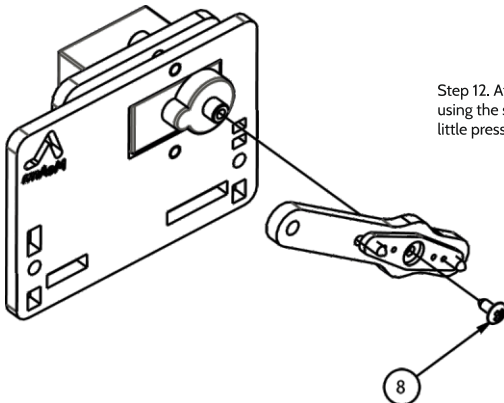

Step 13. Attach the Long Servo Arm Extension assembly to the calibrated LEFT servo motor (using the Brains Board Guide as a reference for position).

Step 14. Use the machine screw from the servo pack to secure in position.

Step 15. (Optional) Power the Brains Board and check that the Long Servo Arm Extension assembly points to approximately 9 o'clock.

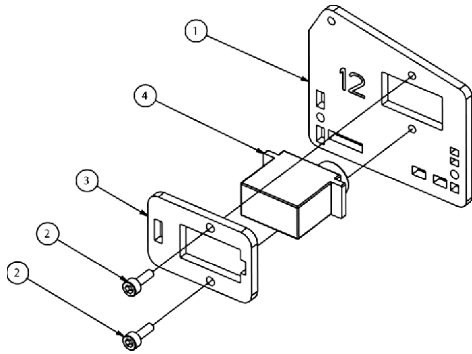

Step 16. Slide Servo Collar over the bottom end of the Servo and insert cable through rectangular hole

Step 17. Insert (2) M3 x 8mm Screws into the Servo Collar and attach to Right Arm Servo Plate

ITEM	PART NAME	QTY	PART NUMBER
1	Right Arm Servo Plate	1	12
2	M3 x 8mm Screw	2	
3	Servo Collar	1	5
4	9 Gram Servo	1	
5	Right Arm Base Joint	1	13
6	Servo Double Arm	1	
7	Servo Mount Screw	2	
8	Parallel Linkage	1	17
9	M3 x 6mm Screw	1	
10	Servo Screw	1	

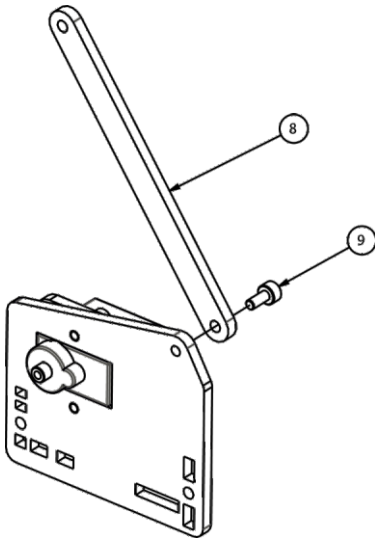

Step 19. Insert 6mm Screw into Parallel linkage and attach to Right Arm Servo Plate.

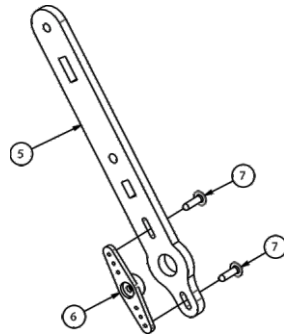

Step 18. Attach the Servo Arm to the Right Arm Base Joint using the sharp screws in the servo pack. These will self tap with a little pressure.

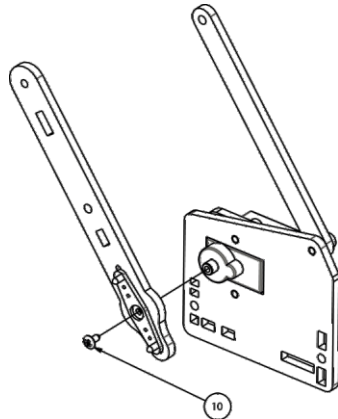

Step 20. Attach the Right Arm Base Joint assembly to the **calibrated RIGHT** servo motor (using the Brains Board Guide as a reference for position).

Step 21. Use the machine screw from the servo pack to secure in position

Step 22. (Optional) Power the Brains Board and check that the Right Arm Base Joint assembly points to approximately 12 o'clock.

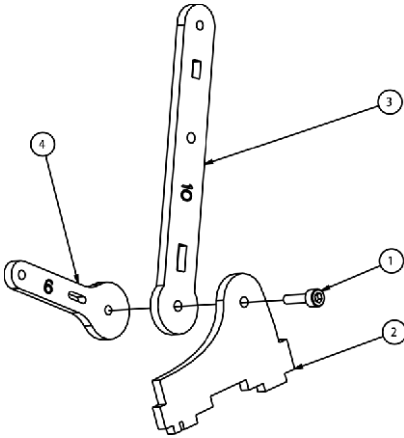

RTS LIST			
ITEM	PART NAME	QTY	
1	M3 x 10mm Screw	1	
2	Left Arm Mount Tablet	1	8
3	Left Arm Base Joint	1	10
4	Short Servo Arm	1	9
5	Arm Bottom Plate	1	14
6	Servo Double Arm	1	
7	Servo Mount Screw	2	

Step 23. Fix parts shown together using 10mm Screw. These should move freely. This assembly is known as the pig.

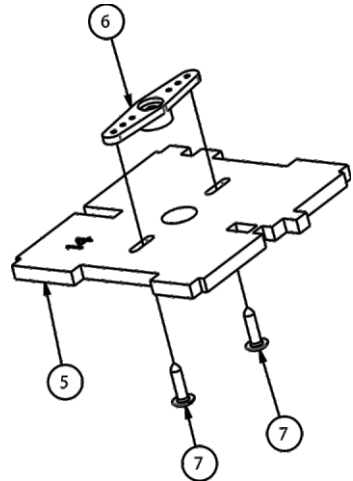

Step 24. Attach the Servo Arm to the Arm Bottom Plate using the sharp screws in the servo pack. These will self tap with a little pressure.

Step 25. Insert the machine screw to attach to the servo later into the Servo Arm as insertion later is a little tricky.

ITEM	PART NAME	QTY	PART NUMBER
1	Front Arm Base Cross Member	1	7
2	Back Arm Base Cross Member	1	11
3	M3 x 12mm Screw	3	
4	Spacer	1	20
5	Parallel Linkage	1	17
6	M3 Nut	2	

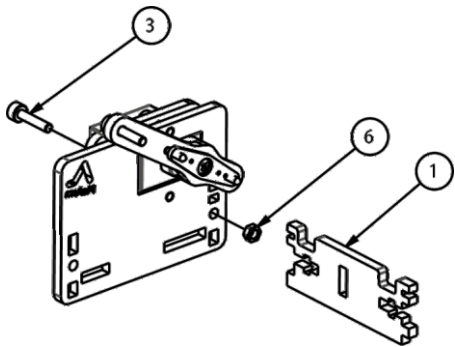

Step 26. Insert (1) 12mm Screw, add nut and Front Arm Base Cross Member and tighten. Stop before you break it.

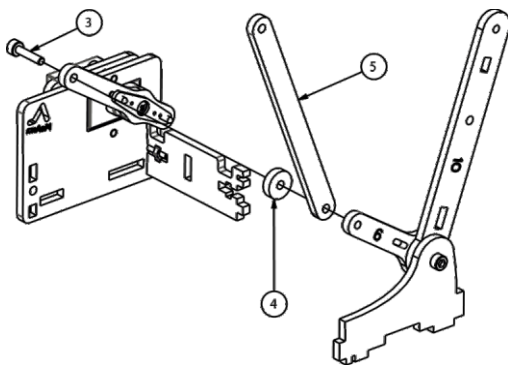

Step 27. Insert the Pig into the Front Arm Base Cross Member and using 12mm Screw attach the Pig to the Long Servo Arm Extension

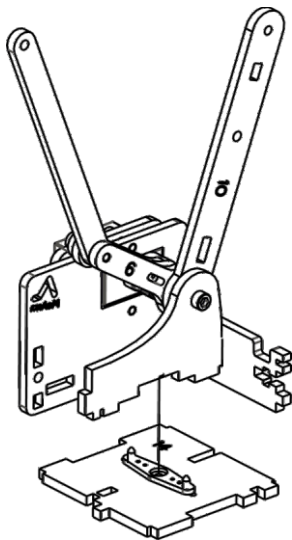

Step 28. Insert the Arm Bottom Plate into the Left Arm Servo Plate at a diagonal angle and lever into place on the Pig Section.

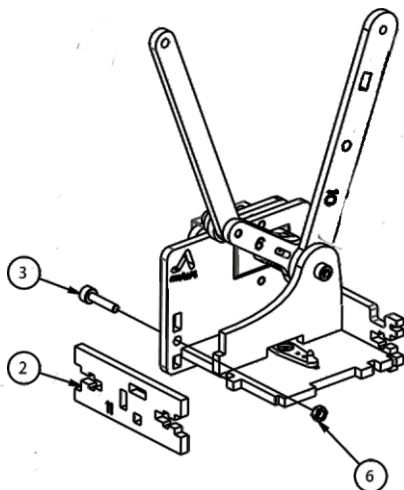

Step 29. Insert 12mm screw, add nut and Rear Arm Base Cross Member and lever carefully onto the rear of the Pig and the Arm Bottom Plate. Leave this screw slightly loose to aid attaching this assembly to the base later.



RTS LIST			
ITEM	PART NAME	QTY	PART NUMBER
1	M3 x 12mm Screw	4	
2	M3 Nut	4	
3	Main Arm Cross Web	1	15

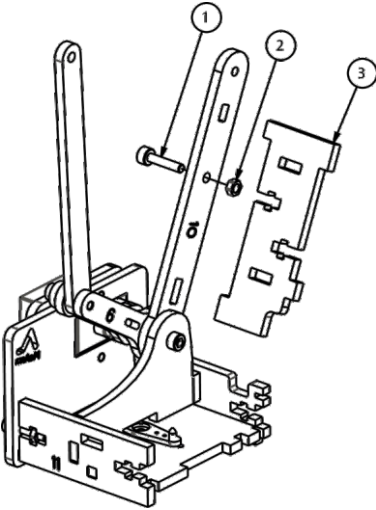

Step 30. Using 12mm Screw and Nut attach Main Arm Cross Web

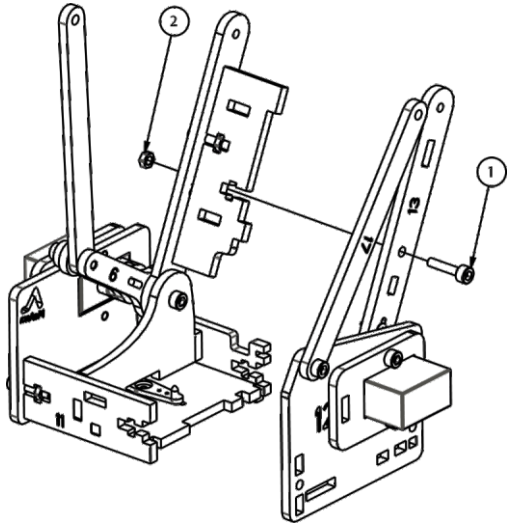

Step 31. Bring the right and left assemblies together securing with a 12mm Screw and Nut in the Main Arm Cross Web.

This part is tricky. Be gentle and have some patience. Small adjustments of the parts will allow it all to push together.

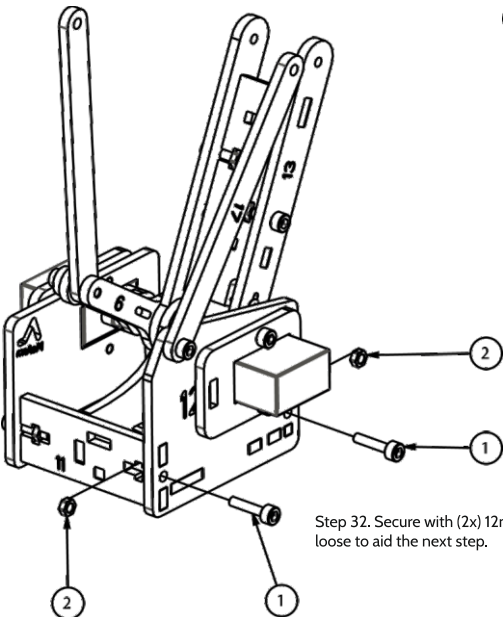

Step 32. Secure with (2x) 12mm Screws and (2x) Nuts. Leave a little loose to aid the next step.

ITEM	PART NAME	QTY	PART NUMBER
1	Servo Screw	1	
2	Left Wrist Joint	1	16
3	M3 x 6mm Screw	2	

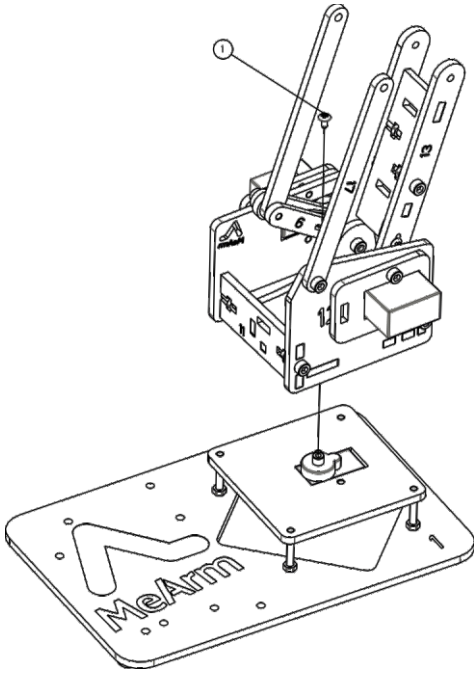

Step 33. Attach Arm Assembly to Base using small machine screw from Servo Pack, which should have been left in the Servo Arm from Step 25.

Step 34. (Optional) Power Brains Board and check that the assembly sits at approximately 12 o'clock relative to the base.

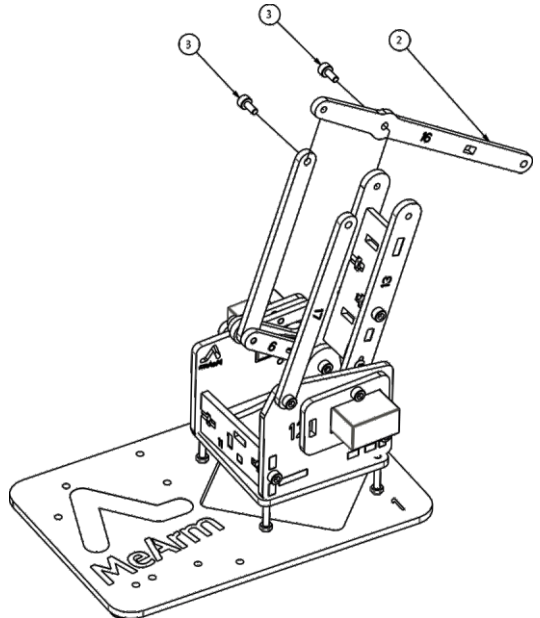

Step 35. Attach using (2) 6mm Screws.

ITEM	PART NAME	QTY	PART NUMBER
1	M3 x 10mm Screw	2	
2	Spacer	1	20
3	Parallel Linkage Connector	1	
4	Parallel Linkage	1	17
5	M3 x 6mm Screw	1	
6	Right Wrist Joint	1	31
7	Wrist Joint Connector	1	18

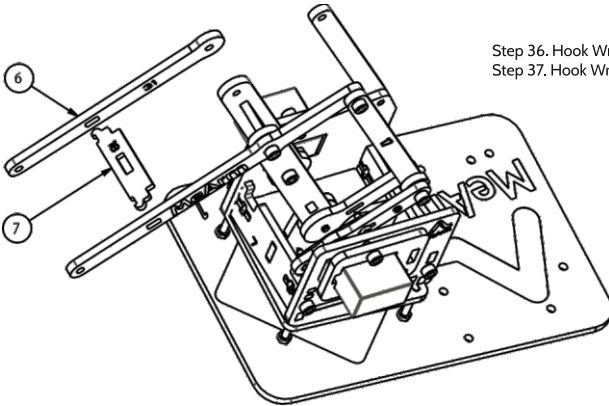

Step 36. Hook Wrist Joint Connector into Right Wrist Joint  
 Step 37. Hook Wrist Joint Connector Assembly into Left Wrist Joint

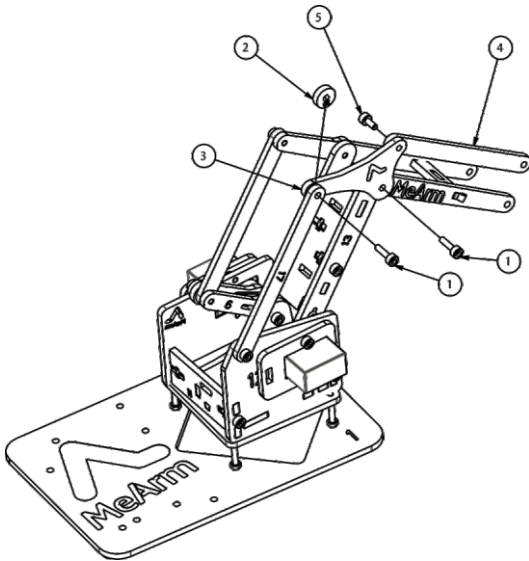

Step 38. Secure Right Wrist Joint with Parallel Linkage Connector and a 10mm Screw

Step 39. Attach Parallel Linkage (from Right Servo Plate) to the Parallel Linkage Connector using 10mm Screw and a Spacer.

Step 40. Attach final Parallel Linkage to the Parallel Linkage connector using a 6mm screw.

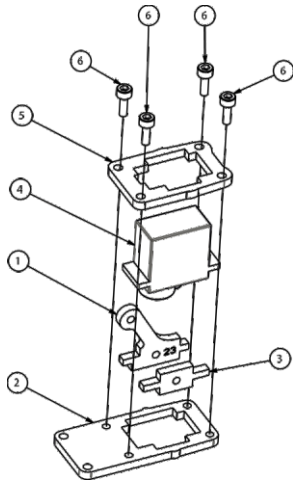

- Step 41. Insert Servo into Clamp Top Servo Collar
- Step 42. Slide Right and Left Wrist Attachments into the Clamp Top Servo Collar as shown
- Step 43. Slide the Clamp Bottom Servo Mount over the Servo
- Step 44. Insert (4x) 8mm Screws into the Clamp Top Servo Collar and attach to the Clamp Bottom Servo Mount

ITEM	PART NAME	QTY	PART NUMBER
1	Right Wrist Attachment	1	23
2	Clamp Bottom Servo Mount	1	24
3	Left Wrist Attachment	1	22
4	9 Gram Servo	1	
5	Clamp Top Servo Collar	1	21
6	M3 x 8mm Screw	6	
7	Right Gripper	1	27
8	Left Gripper	1	28
9	Gripper Plate	1	25
10	Gripper Gear	1	26
11	Top Servo Gear	1	30
12	Servo Single Arm	1	
13	Servo Mount Screw	1	
14	Servo Screw	1	
15	Bottom Servo Gear	1	29
16	M3 x 6mm Screw	2	
17	M3 x 12mm Screw	1	

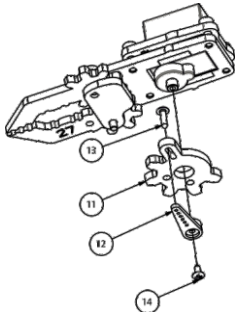

- Step 46. Attach Servo Single Arm to Top Servo Gear and attach to calibrated CLAW servo (using the Brains Board Guide as reference).
- NOTE. On the calibrated CLAW Servo the Servo Arm assembly and longest lug should point towards 6 o'clock (Gripper at 12 o'clock)

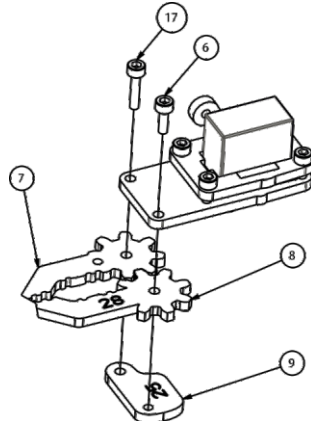

- Step 45. Attach Left Gripper with 8mm Screw into Gripper Plate
- Insert 12mm Screw to keep assembly in place (does not tighten yet)

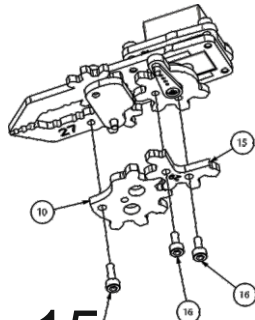

- Step 47. Connect Bottom Servo Gear using 6mm Screws.
- Step 48. Attach Gripper Gear with 8mm Screw from underside and 12mm Screw (previously inserted from above). **IMPORTANT NOTE!** Jaws should be set open to 90 degrees (180 degrees to each other) when meshed with calibrated servo gear! **NOT AS SHOWN**

15

PARTS LIST			
ITEM	PART NAME	QTY	PART NUMBER
1	Spacer	1	20
2	M3 x 8mm Screw	3	

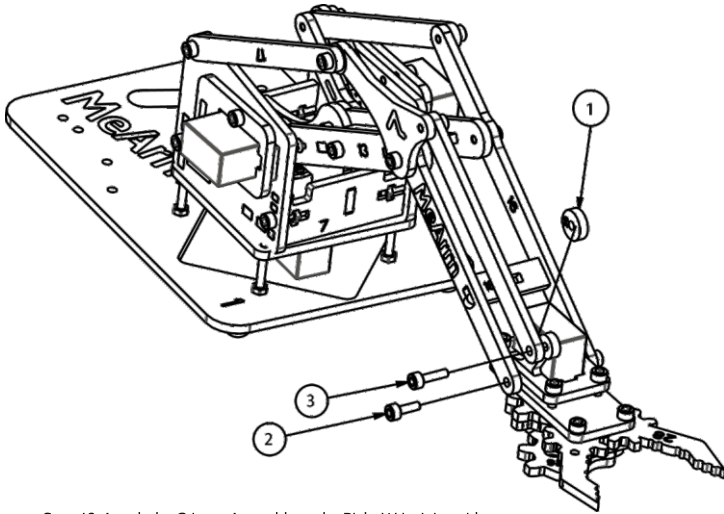

Step 49. Attach the Gripper Assembly to the Right Wrist Joint with 8mm Screw  
 Step 50. Connect the Parallel Linkage with a 8mm Screw and Spacer

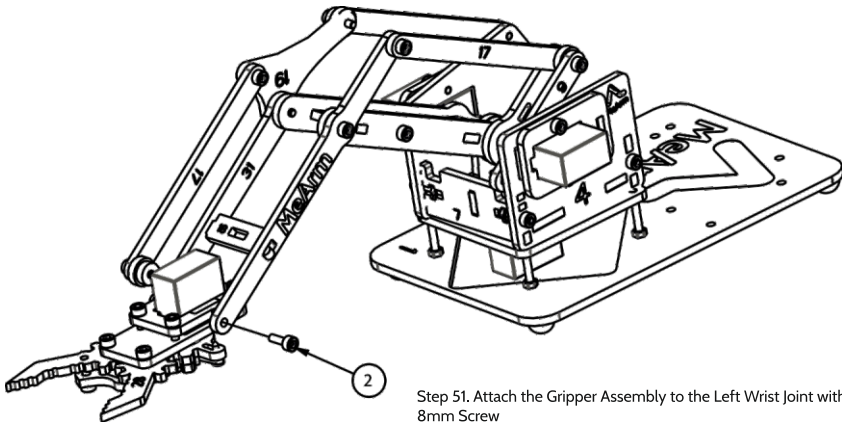

Step 51. Attach the Gripper Assembly to the Left Wrist Joint with 8mm Screw  
 Step 52. Thread CLAW Servo cable through cable guides and attach Servo Extension to reach Brains Boards.  
 Step 53. Attach Brains Board to mounting holes in base plate.

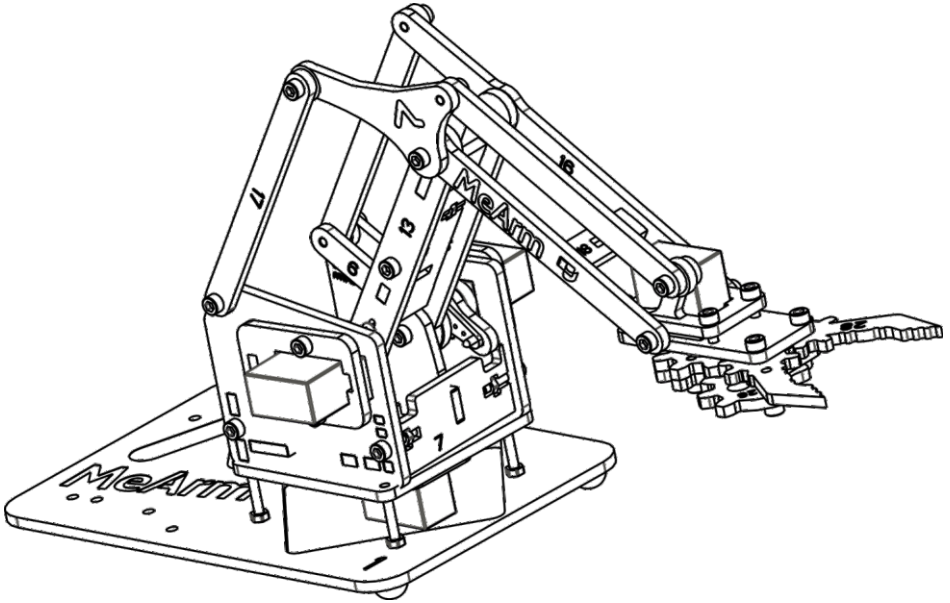

# Congratulations!

Now you've completed your MeArm! It's now ready to control with your Brains Board. For Joysticks controllers it should be ready to play right away. For the Sliders reset the Brains Board and hold the right button for 5-10 seconds on start up to enable Slider control.

We'll be adding to this guide so please check back and in the mean time we hope to see you on our forums at [forum.mearm.io](http://forum.mearm.io)

Many thanks for supporting the MeArm project!