

# **MSP Debuggers**

This manual describes the use and the features of all MSP debug probes. It includes information about the debugger probe hardware and software. It documents frequently asked questions on how to enable and disable certain features. It shows the differences between the debug probes and offers a guide on how to identify the specific version of the debug probe hardware.

### **Contents**

1	Introduction .....	3
2	MSP Debug Probe Overview.....	4
3	Hardware Identification.....	5
4	Hardware Installation .....	7
5	Debug Probes Hardware and Software .....	11

### **List of Figures**

1	eZ-FET Windows Enumeration .....	5
2	eZ-FET Emulation IP .....	5
3	eZ-FET Lite Emulation IP .....	5
4	eZ430 Emulation IP .....	6
5	eZ430 Windows Enumeration.....	6
6	MSP Flasher Driver Install Notification.....	9
7	CCS Cloud Agent Installation.....	10
8	Successful CCS Cloud Agent Installation .....	10
9	MSP Ecosystem .....	11
10	MSP-FET Top View .....	13
11	MSP-FET Bottom View .....	13
12	MSP-FET 14-Pin JTAG Connector .....	16
13	MSP-FET USB Debugger, Schematic (1 of 5) .....	18
14	MSP-FET USB Debugger, Schematic (2 of 5) .....	19
15	MSP-FET USB Debugger, Schematic (3 of 5) .....	20
16	MSP-FET USB Debugger, Schematic (4 of 5) .....	21
17	MSP-FET USB Debugger, Schematic (5 of 5) .....	22
18	MSP-FET USB Debugger, PCB (Top).....	22
19	MSP-FET USB Debugger, PCB (Bottom).....	22
20	MSP-FET430UIF Version 1.4a Top and Bottom Views .....	24
21	MSP-FET430UIF Version 1.3 Top and Bottom Views .....	24
22	MSP-FET430UIF 14-Pin JTAG Connector.....	25
23	MSP-FET430UIF USB Interface, Schematic (1 of 4).....	27
24	MSP-FET430UIF USB Interface, Schematic (2 of 4).....	28
25	MSP-FET430UIF USB Interface, Schematic (3 of 4).....	29

MSP430, E2E, EnergyTrace are trademarks of Texas Instruments.  
 OS X is a registered trademark of Apple, Inc.  
 IAR Embedded Workbench is a trademark of IAR Systems.  
 Linux is a registered trademark of Linus Torvalds.  
 Windows is a registered trademark of Microsoft Corporation.  
 All other trademarks are the property of their respective owners.

26	MSP-FET430UIF USB Interface, Schematic (4 of 4) .....	30
27	MSP-FET430UIF USB Interface, PCB .....	31
28	eZ-FET and eZ-FET Lite Top Views .....	32
29	eZ-FET or eZ-FET Lite Debug Connector .....	34
30	MSP-FET to LaunchPad Pin Assignments .....	35
31	MSP-FET to LaunchPad Wiring Diagram .....	35
32	eZ-FET Schematic (USB Connection) .....	36
33	eZ-FET Schematic (Emulation MCU) .....	37
34	eZ-FET Schematic DCDC (No eZ-FET Lite) .....	38
35	eZ430 Emulation .....	39
36	eZ430 Debug Connector on MSP-EXP430G2 LaunchPad .....	40
37	eZ430 Schematic (Emulation MCU) .....	41
38	eZ430 Schematic (USB Connection) .....	42
39	MSP-FET430PIF .....	43
40	MSP-FET430PIF FET Interface Module, Schematic .....	44
41	MSP-FET430PIF FET Interface Module, PCB .....	45

#### List of Tables

1	Debug Probes Features and Device Compatibility .....	4
2	MSP-FET Backchannel UART Implementation .....	14
3	MSP-FET Backchannel UART Activation Commands .....	15
4	MSP-FET MSP Target BSL Activation Commands .....	15
5	MSP-FET LED Signals .....	16
6	MSP-FET Pin States .....	17
7	MSP-FET430UIF LED Signals .....	25
8	MSP-FET430UIF Pin States .....	26
9	eZ-FET and eZ-FET Lite Backchannel UART Implementation .....	33
10	eZ-FET and eZ-FET Lite Backchannel UART Activation Commands .....	33
11	eZ-FET LED Signals .....	34
12	eZ-FET and eZ-FET Lite Pin States .....	35
13	eZ430 Backchannel UART Implementation .....	40
14	eZ430 Pin States .....	40

## 1 Introduction

### 1.1 Related Documentation From Texas Instruments

*MSP430™ Hardware Tools User's Guide* ([SLAU278](#))

*IAR Embedded Workbench™ Version 3+ for MSP430™ User's Guide* ([SLAU138](#))

*Advanced Debugging Using the Enhanced Emulation Module (EEM) With Code Composer Studio™ Version 6* ([SLAA393](#))

*MSP430™ Programming With the Bootloader (BSL)* ([SLAU319](#))

*MSP430™ Programming Via the JTAG Interface* ([SLAU320](#))

### 1.2 Terms and Abbreviations

Term	Definition
BSL	Bootloader
CCS	Code Composer Studio development tool for MSP430
CDC	Communications device class
CPU	Central processing unit
CRC	Cyclic redundancy check
CTS	Clear to send
FET	Flash emulation tool
I <sup>2</sup> C	Inter-Integrated Circuit 2-wire communication bus
IAR EW430	IAR Embedded Workbench development tool for MSP430
JTAG	Joint Test Action Group
JTAG 4-wire	4-wire JTAG protocol communication
MCLK	Master clock
MSP	Mixed signal processor
<a href="#">MSP-FET</a>	MSP debug probe
<a href="#">MSP-FET430 UIF</a>	MSP debug probe
MSPDebugStack	Dynamic library (Windows®), shared object (Linux®), or dy library (OS X®) that offers functions to access and debug MSP430 devices using an MSP debug probe
PC	Personal computer
RTS	Request to send
RX	Receive data
SBW	Spy-Bi-Wire (2-wire JTAG protocol) communication
TX	Transmit data
UART	Universal asynchronous receiver/transmitter
UIF	USB interface to debug and access MSP derivatives
USB	Universal serial bus

### 1.3 If You Need Assistance

Support for the MSP microcontrollers and the development tools is provided by the TI Product Information Center (PIC). Contact information for the PIC can be found on the TI website at [www.ti.com/support](http://www.ti.com/support). The [TI E2E™ Community](#) support forums for the MSP microcontrollers also provide open interaction and support from a community of peer engineers, TI engineers, and other experts. Additional device-specific information can be found on the [MSP website](#).

## 2 MSP Debug Probe Overview

Table 1 is an overview of the capabilities and features for the available MSP debug probes.

**Table 1. Debug Probes Features and Device Compatibility<sup>(1)(2)(3)</sup>**

Feature and MSP430 Device Support	eZ430-F2013	eZ430-RF2500	eZ430-RF2480	eZ430-RF2560	MSP-WDSxx Metawatch	eZ430-Chronos	LaunchPad (MSP-EXP430G2)	MSP-EXP430FR5739	MSP-EXP430F5529	MSP-FET430PIF	MSP-FET430UIF	MSP-FET	eZ-FET Emulation IP	eZ-FET Lite Emulation IP
Supports all programmable MSP430 and CC430 devices										✓	✓	✓	✓	✓
Supports only F20xx, G2x01, G2x11, G2x21, G2x31	✓													
Supports F20xx, F21x2, F22xx, G2x01, G2x11, G2x21, G2x31, G2x53							✓							
Supports F20xx, F21x2, F22xx, G2x01, G2x11, G2x21, G2x31		✓	✓											
Supports F5438, F5438A				✓										
Supports BT5190, F5438A				✓	✓									
Supports only F552x									✓					
Supports FR57xx, F5638, F6638								✓						
Supports only CC430F613x						✓								
Allows JTAG access protection (Fuse Blow) <sup>(4)</sup>											✓	✓		
Adjustable target supply voltage											✓	✓		
Fixed 2.8-V target supply voltage										✓				
Fixed 3.3-V target supply voltage													✓	✓
Fixed 3.6-V target supply voltage	✓	✓	✓	✓	✓	✓	✓	✓	✓					
4-wire JTAG										✓	✓	✓		
2-wire JTAG <sup>(5)</sup>	✓	✓	✓	✓	✓	✓	✓	✓	✓		✓	✓	✓	✓
BSL tool or mode												✓		
Backchannel UART		✓	✓	✓	✓	✓	✓	✓	✓			✓	✓	✓
Supported by CCS for Windows	✓	✓	✓	✓	✓	✓	✓	✓	✓	✓	✓	✓	✓	✓
Supported by CCS for Linux											✓	✓	✓	✓
Supported by CCS for OS X											✓	✓	✓	✓
Supported by IAR	✓	✓	✓	✓	✓	✓	✓	✓	✓	✓	✓	✓	✓	✓
EnergyTrace™, EnergyTrace++												✓	✓	

<sup>(1)</sup> The MSP-FET430PIF is for legacy device support only. This emulation tool does not support any devices released after 2011.

<sup>(2)</sup> Refer to [Section 3.1](#) to identify the hardware.

<sup>(3)</sup> The eZ-FET Emulation IP and eZ-FET Lite Emulation IP are used as the onboard emulation for the MSP LaunchPad tools.

<sup>(4)</sup> Refer to [Section 5.5](#) for more information.

<sup>(5)</sup> The 2-wire JTAG debug interface is also referred to as Spy-Bi-Wire (SBW) interface.

### CAUTION

Never disconnect the JTAG or emulator USB cable during an active debug session. Always terminate a running debug session properly, by clicking on the "Terminate" icon, before disconnecting the target device.

### 3 Hardware Identification

#### 3.1 How to Determine If Your Hardware is Based on eZ-FET or eZ-FET Lite

- Check the installed tool drivers by using the Windows Device Manager. eZ-FET tools enumerate as CDC "MSP Debug Interface" and CDC "MSP Application UART1" devices (see Figure 1).
- Check the Experimenter Board or LaunchPad emulation section to find out if it is based on an eZ-FET tool. If it is based on an MSP430F5528 device, it is an eZ-FET tool.
- There is a small print on the silkscreen that indicates eZ-FET or eZ-FET Lite (see Figure 2 and Figure 3).

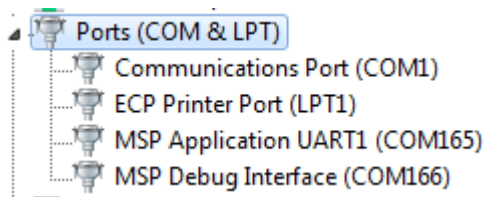

Figure 1. eZ-FET Windows Enumeration

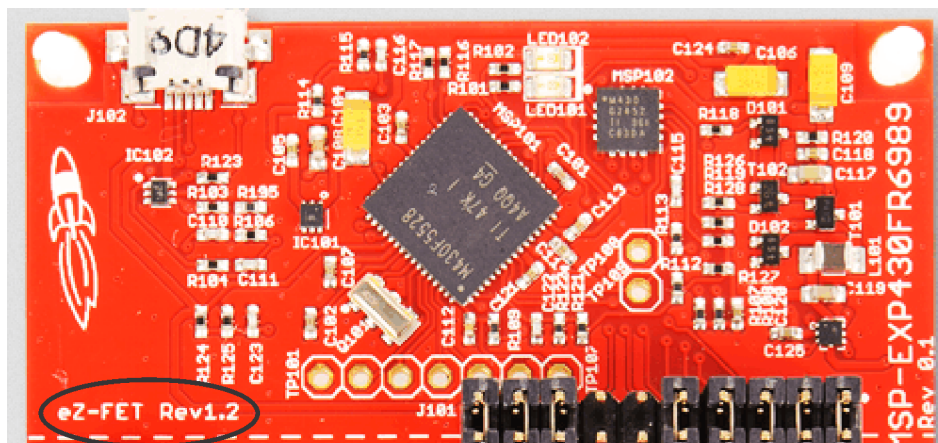

Figure 2. eZ-FET Emulation IP

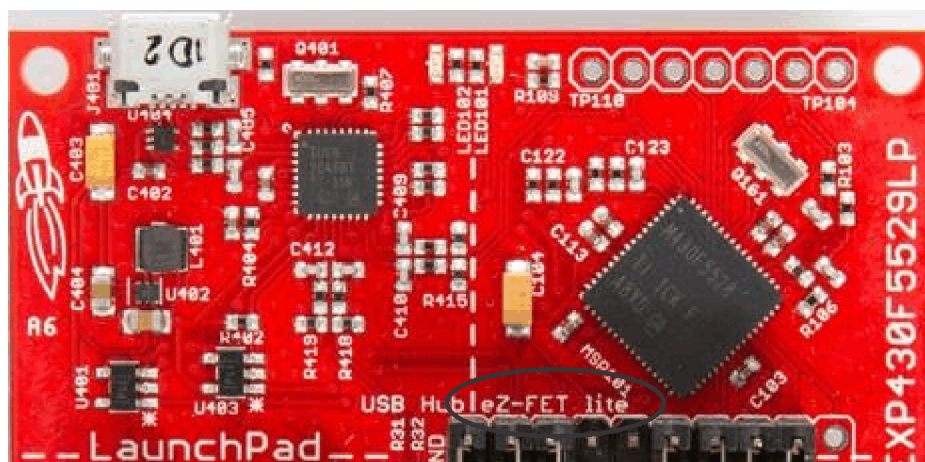

Figure 3. eZ-FET Lite Emulation IP

### 3.2 How to Determine If Your Hardware is Based on eZ430

- Check the installed tool drivers by using the Windows Device Manager (see [Figure 5](#)). eZ430 tools enumerate as HID (Debugger port) and CDC (Backchannel UART) devices.
- Check the Experimenter Board to find out if it is based on an eZ430 tool (see [Figure 4](#)). If it is based on an MSP430F1612 and a TUSB3410, it is an eZ430 tool.



Figure 4. eZ430 Emulation IP

USB Composite Device	✓ Ready to use
MSP430 Application UART (COM205)	✓ Ready to use
USB Input Device	✓ Ready to use

Figure 5. eZ430 Windows Enumeration

### 3.3 Signal Connections for In-System Programming and Debugging

For details about the hardware connections of all debug probes refer to the "Signal Connections for In-System Programming and Debugging" section of the *MSP430 Hardware Tools User's Guide* ([SLAU278](#)).

### 3.4 Using the Power Supply Feature of the eZ-FET and eZ-FET Lite

The eZ-FET and the eZ-FET Lite only support a fixed voltage power supply. The maximum supply current is 75 mA. For more details, refer to the specific LaunchPad or experimenter board user's guide.

---

**NOTE:** These debug probes do not support externally powering of the device while debugging – if an external voltage is needed for stand-alone testing, the eZ-FET emulation section should not be connected through USB. If both external power and the USB power are connected, there could be a conflict that can damage the device.

---

### 3.5 Using the Power Supply Feature of the MSP-FET430UIF and MSP-FET

All MSP debug probes can supply targets with up to 100 mA through pin 2 of the 14-pin JTAG connector.

---

**NOTE:** The target should not consume more than 60 mA at peak current, as it may violate the USB specification. Details can be found on [www.USB.org](http://www.USB.org).

---

**Example:** If the target board has a capacitor on the  $V_{CC}$  line with a capacity of more than 10  $\mu F$ , it may cause an inrush current during capacitor charging that may exceed 60 mA. In this case, the current should be limited by the design of the target board, or an external power supply should be used.

Target  $V_{CC}$  is selectable in a range between 1.8 V and 3.6 V in steps of 0.1 V.

Alternatively, the target can be supplied externally. In this case, the external voltage should be connected to pin 4 of the 14-pin JTAG connector. MSP-FET tools adjust the level of the JTAG signals to automatically match the external  $V_{CC}$ .

---

**NOTE:** Only pin 2 (MSP-FET tool supplies target) or pin 4 (target is externally supplied) must be connected. Both connections are not supported at the same time.

Even if an external supply powers the target device on the target socket module and any user circuitry connected to the target socket module, the MSP-FET tool continues to be powered from the PC through the USB interface.

---

**NOTE: MSP-FET430PIF only**

The PC parallel ports with a connected MSP-FET430PIF can source a maximum current of 25 mA. Because of the ultra-low-power requirement of the MSP430, a stand-alone MSP430 does not exceed the provided current. However, if additional circuits are added, the current limit could be exceeded. In this case, the MSP430 must be supplied externally.

---

## 4 Hardware Installation

This section describes how to install the drivers for all MSP debug probes. The drivers are needed to enable the IDE (integrated development environment) to use the debug probe that is connected to the system. There are four different ways to install the drivers.

1. CCS desktop: During the CCS setup, all MSP debug probe drivers are installed automatically for all supported operation systems.
2. CCS cloud: The automatic driver installer is included inside the TI Cloud Agent Application, which must be downloaded when connecting a local MSP debug probe to CCS cloud.
3. Stand-alone driver installer: The stand-alone driver installer is only available for Windows. It installs all MSP debug probe drivers automatically.
4. Using another supported IDE such as IAR EW430 or the MSP-Flasher: During the setup, all MSP debug probe drivers are installed automatically.

### 4.1 MSP-FET430PIF

The MSP-FET430PIF has the following system requirements:

It supports only Windows XP with IAR EW430 version 5.xx.x and Code Composer Studio version 5.x.x. No new development is scheduled to support MSP-FET430PIF.

Follow these steps to install the hardware for the MSP-FET430PIF tool:

1. Use the 25-pin ribbon cable to connect the debugger interface module to the parallel port of the PC. The necessary driver for accessing the PC parallel port is installed automatically during CCS or IAR Embedded Workbench installation. Note that a restart is required after the CCS or IAR Embedded Workbench installation.
2. Use the 14-pin ribbon cable to connect the parallel-port debug interface to a target board which contains the target MSP430 device.

### 4.2 MSP-FET430UIF, MSP-FET, eZ-FET, and eZ-FET Lite

---

**NOTE:** The built-in DC-DC converter of the MSP-FET and eZ-FET emulators causes a load-dependent amount of ripple on the output voltage ( $f_{\text{ripple}} = 1 \text{ kHz to } 50 \text{ kHz}$ ,  $V_{\text{rms\_ripple}} = 5 \text{ mV to } 50 \text{ mV}$ ), which might affect sensitive analog and RF circuits that are supplied by the emulator. For such sensitive circuits, TI recommends temporarily increasing the amount of power supply decoupling used during development, using an emulator with an integrated linear regulator (MSP-FET430UIF or eZ-FET430), or using a separate bench supply.

---

Installation steps for the MSP-FET430UIF, MSP-FET, eZ-FET or eZ-FET Lite:

1. Install the IDE (TI CCS or IAR EW430) before connecting the debug probe to the PC. During IDE installation, the USB drivers for the debug probes are installed automatically. Make sure to use the latest IDE version; older versions might install USB drivers that do not recognize the connected debug probe.
2. Connect the debug probe to a USB port on the PC using the provided USB cable.
3. The following procedure applies to operation under Windows:
  - (a) After connecting to the PC, the debug probe should be recognized automatically, as the USB device driver has been already installed together with the IDE.
  - (b) However, if the driver is not automatically detected, the "Found New Hardware wizard" starts. Follow the instructions and point the wizard to the driver files.

The default location for CCS is: `c:\ti\ccsv6\ccs_base\emulation\drivers\msp430\USB_CDC`.

The default location for IAR Embedded Workbench is: `<Installation Root>\Embedded Workbench x.x\430\drivers\<Win_OS>`.
4. After connecting the debug probe to a PC, the probe performs a self-test. If the self-test passes, the green LED stays on. For a complete list of LED signals, refer to the "LED Signals" of each debug probe in [Section 5.6](#) through [Section 5.8](#).
5. Connect the debug probe with the target board using the 14-pin ribbon cable.
6. When using a target socket board, make sure that the MSP430 device is properly inserted in the socket and that pin 1 of the device (indicated with a circular indentation on the top surface) aligns with the "1" mark on the PCB.

---

**NOTE:** To use the debug probe without an IDE, install the stand-alone driver package. The stand-alone driver installer can be found at <http://www.ti.com/mspds> under the heading MSPDS-USB-DRIVERS.

---

### 4.3 eZ430-Based Experimenter Boards and LaunchPad Kits

For driver installation on a Windows operating system, follow the steps in [Section 4.2](#).

---

**NOTE:** eZ430-tools are not supported on USB3.0 ports. eZ430 tools are only supported on Windows operating systems – Linux and OS X are not supported.

---

### 4.4 Hardware Installation Using the MSP Flasher

The MSP430 Flasher is an open-source shell-based interface for programming any MSP430 device through a [MSP Debug Stack](#) and provides the most common functions on the command line. MSP430 Flasher can be used to download binary files (.txt or .hex) directly to the MSP430 memory without the need for an IDE like CCS or IAR. It can also be used to extract firmware directly from a device, set hardware breakpoints, and lock JTAG access permanently. MSP430 Flasher supports the following operating systems:

- Windows 10 32-bit or 64-bit
- Windows 8 32-bit or 64-bit
- Windows 7 32-bit or 64-bit
- Windows XP 32-bit or 64-bit
- Ubuntu 12.04 32-bit
- OS X Mavericks 10.9 64-bit



Installation steps for the MSP-FET430UIF, MSP-FET, eZ-FET or eZ-FET Lite:

1. After successfully downloading and executing the MSP Flasher installer, it prompts you to execute the [stand-alone driver installer](#) for the MSP debug probes.

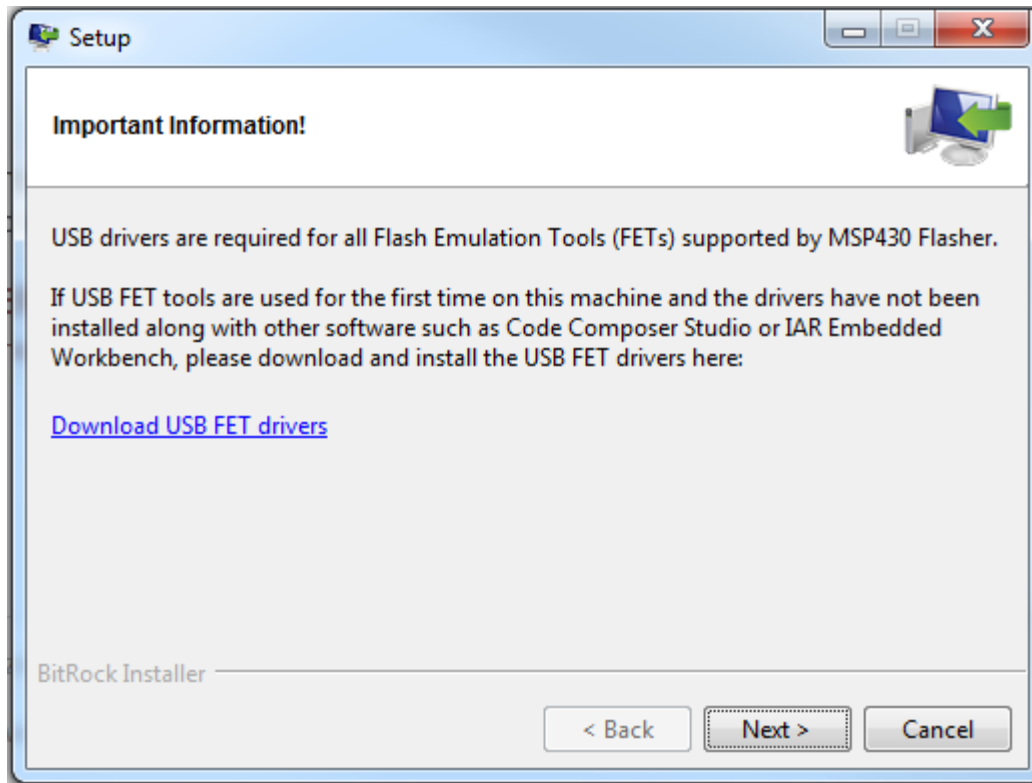

**Figure 6. MSP Flasher Driver Install Notification**

2. Follow the steps given by the stand-alone driver installer for debug probe driver installation.
3. After successful driver installation, connect the debug probe to a USB port on the PC using the provided USB cable.
4. After connecting the debug probe to a PC, it performs a self-test. If the self-test passes, the green LED stays on. For a complete list of LED signals, refer to the "LED Signals" of every debug probe in [Section 5.6](#) through [Section 5.8](#).
5. Connect the debug probe with the target board using the 14-pin ribbon cable.
6. When using a target socket board, make sure that the MSP430 device is properly inserted in the socket and that its pin 1 (indicated with a circular indentation on the top surface) aligns with the "1" mark on the PCB.

#### 4.5 Hardware Installation Using CCS Cloud

CCS Cloud is web-based IDE that allows you to create, edit, and build CCS and Energia projects. After a project is successfully built, it can be downloaded and run on the connected LaunchPad or any other debug probe. Basic debugging features, like setting breakpoints or viewing values of target variables are now supported.

CCS Cloud can be used with the local debug probe connected to the PC through USB. To support this configuration, install the "CCS Cloud browser extension", and download and install the "TI Cloud Agent Application". For more details, refer to the CCS cloud documentation at [http://processors.wiki.ti.com/index.php/TI\\_Cloud\\_Agent](http://processors.wiki.ti.com/index.php/TI_Cloud_Agent).

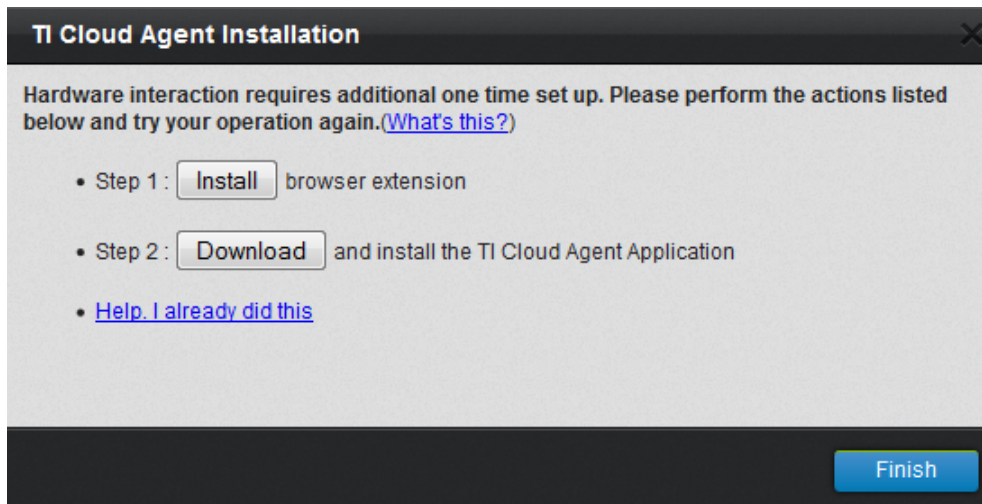

Figure 7. CCS Cloud Agent Installation

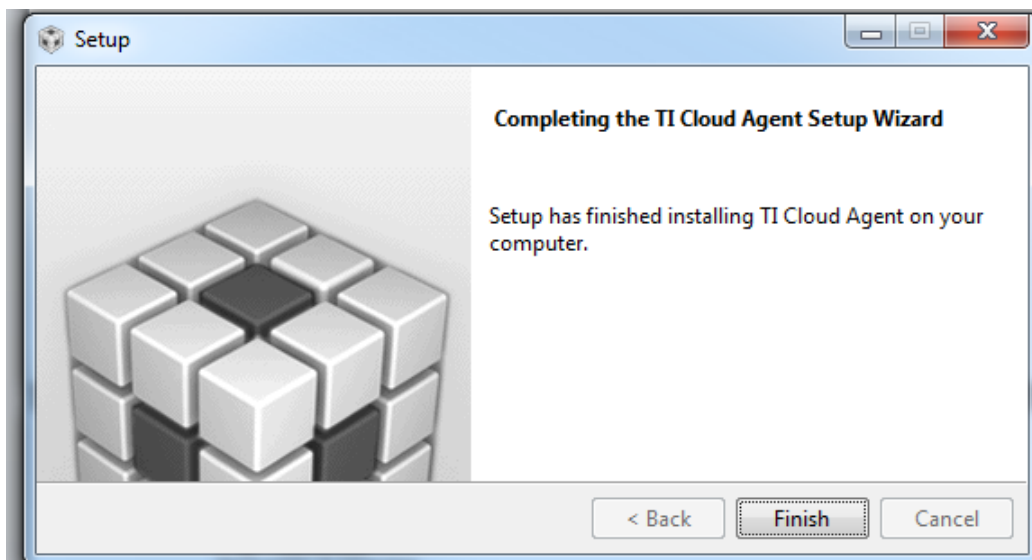

Figure 8. Successful CCS Cloud Agent Installation

After the successful Agent installation, download the application by clicking the Flash or Debug button in CCS Cloud.

## 5 Debug Probes Hardware and Software

This section includes all specifications and features of all MSP debug probes. The debug probe hardware and different debug mode configuration and setting are described.

Figure 9 is an overview of the MSP ecosystem showing the relations between IDE and debug probe and the MSP device itself.

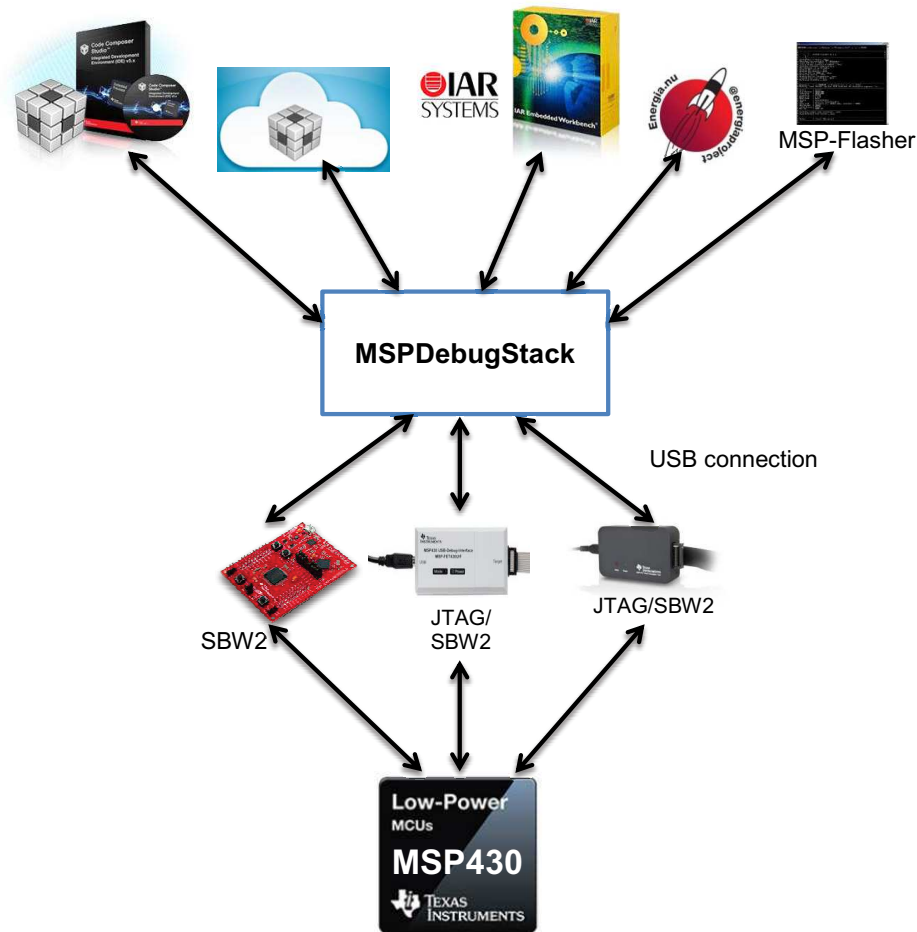

Figure 9. MSP Ecosystem

### 5.1 MSPDebugStack

The MSPDebugStack is the host side interface to all MSP debug probes. It is a library for controlling and debugging Texas Instruments MSP ultra-low power microcontrollers during software development phase.

For this purpose the MSP microcontroller is controlled by the MSPDebugStack using the MSP device's JTAG interface. The MSPDebugStack provides device control (for example, run and stop), memory programming and debugging functionality (for example, breakpoints).

The MSPDebugStack supports Windows, Linux, and OS X operating systems.

The debug probe firmware for all field updatable tools is included in the MSPDebugStack. It automatically detects if an update of the debug probe is required.

For more details and information see [www.ti.com/mspds](http://www.ti.com/mspds).

## 5.2 Ultra-Low-Power Debug Support

Ultra-low power (ULP) debug support enables users to debug in the low-power modes that are used in their application software.

If this option is enabled during an active debug session in IAR EW430 or Code Composer studio, the target MSP430 device enters the low-power modes. Wake-up times can be measured on F5xx, F6xx, FR5xx, and FR6xx devices. For some MSP430 devices, special debug features are disabled in this mode; for example, setting breakpoints (hardware and software) while device is running in ULP mode.

---

**NOTE:** When debugging with EnergyTrace++ active, this mode must be used.

---

**NOTE:** Measured currents might be slightly higher than in stand-alone mode (EnergyTrace) due to the active debugger connection.

For more details and information refer to the *MSP430 Ultra-Low-Power LPMx.5 Mode* section of the IDE user's guides for IAR EW430 ([SLAU138](#)) and CCS ([SLAU157](#)).

---

## 5.3 EnergyTrace™ Technology

EnergyTrace Technology is an energy-based code analysis tool that measures and displays the application's energy profile, which helps to optimize it for ultra-low power consumption.

MSP devices with built-in **EnergyTrace+[CPU State]+[Peripheral States]** (or in short **EnergyTrace++**) technology allow real-time monitoring of many internal device states while user program code executes. EnergyTrace++ technology is supported on selected MSP devices and debuggers (see [Table 1](#)).

**EnergyTrace** mode (without the "+") is a fundamental part of **EnergyTrace Technology** and enables analog energy measurement to determine the energy consumption of an application but does not correlate it to internal device information. The EnergyTrace mode is available for all MSP devices with selected debuggers, including CCS (see [Table 1](#)).

For more details about the EnergyTrace Technology, refer to <http://www.ti.com/tool/energytrace>.

## 5.4 Unlimited Software Breakpoints in Flash, FRAM, and RAM

All MSP430 debug tools support the use of Software breakpoints in Flash, FRAM, and RAM. Software breakpoints enable the user to set an unlimited number of breakpoints during an active debug session.

Without Software Breakpoints enabled, the number of breakpoints which can be set is limited to the number of hardware breakpoints available by the specific MSP device.. All MSP debug tools prefer the use of hardware breakpoints as much as possible. However, if the MSP breakpoint logic runs out of hardware breakpoints, software breakpoints are used automatically (if enabled in the IDE).

---

**NOTE:** When the debug session is closed, all software breakpoints are erased and the original memory content is restored.

For more details about the software breakpoints and their IDE-specific use, refer to the "Breakpoint Types" section in the IDE user's guides for IAR EW430 ([SLAU138](#)) and CCS ([SLAU157](#)).

For a practical example of different breakpoint types, refer to the application report *Advanced Debugging Using the Enhanced Emulation Module (EEM) With Code Composer Studio Version 6* ([SLAA393](#)).

---

## 5.5 JTAG Access Protection (Fuse Blow)

Different MSP430 devices implement different methods to prevent JTAG debug access to the MSP430 target device.

JTAG fuse:

- Available on 1xx, 2xx, and 4xx families (except FRxx and I20xx devices).
- Applying a high voltage to test the TEST pin of the MSP430 target device blows an actual physical polyfuse and disables the JTAG interface.

JTAG lock without password (eFuse/"soft" fuse):

- Available on 5xx, 6xx, and FRxx families.
- A certain lock pattern is written into the MSP430 target memory to disable the JTAG interface.

JTAG lock with password:

- Available only FRxx families.
- A user-defined password can disable JTAG access to the MSP430 target device.
- Using CCS, EW430, or the MSP Flasher, applying the configured password to the MSP430 target restores JTAG access

Memory protection by custom startup code (SUC):

- Available on only the i20xx family (for example, the MSP430i2040 device).
- Custom startup code can enable or disable JTAG access to the MSP430i20xx target device.

---

**NOTE:** Only the MSP-FET and the MSP-FET430UIF support JTAG access protection to disable JTAG access.

For more details how the JTAG access protection mechanism is implemented refer to the "JTAG Access Protection" section in *MSP430 Programming Via the JTAG Interface* ([SLAU320](#)).

---

## 5.6 MSP-FET Stand-Alone Debug Probe

The MSP-FET is a powerful debug probe for application development supporting all MSP430 microcontrollers.

The MSP-FET provides a USB interface to program and debug the MSP430 devices in-system through the JTAG interface or the pin-saving Spy-Bi-Wire (2-wire JTAG) protocol. Furthermore, the USB interface can be used for Backchannel UART and MSP target BSL communication. UART BSL and I<sup>2</sup>C BSL communication modes are supported.

The MSP-FET development tool supports development with all MSP430 devices and is designed for use with PCBs that contain MSP430 devices; for example, the MSP430 target socket boards.



Figure 10. MSP-FET Top View



Figure 11. MSP-FET Bottom View

### 5.6.1 General Features

The following features are provided by the MSP-FET debug probe.

Features:

- Operating systems: OS X, Linux, Windows
- Software configurable supply voltage between 1.8 V and 3.6 V at 100 mA
- External voltage detection
- Supports JTAG security fuse blow to disable debugging
- Supports all MSP430 boards with JTAG header
- Supports both JTAG and Spy-Bi-Wire (2-wire JTAG) debug protocols
- EnergyTrace and EnergyTrace++ support
- Software breakpoints in Flash, FRAM, and RAM
- MSPDS application backchannel UART included
- Target BSL communication mode available
- Flash and FRAM programming support
- Debug probe firmware field update is supported <sup>(4)</sup>

### 5.6.2 Backchannel UART

The MSP-FET supports the Backchannel UART functionality only when using an MSPDebugStack v3.4.1.0 or higher for the MSP-FET connection.

The baud rates that are supported depend on the target configuration and the debug settings. [Table 2](#) shows which baud rates are supported with certain configuration combinations.

✓ means that the corresponding baud rate is supported without any data loss with the specified combination of settings.

✗ means that the corresponding baud rate is not supported (data loss is expected) with the specified combination of settings.

<sup>(4)</sup> Enable new device support by in field firmware updates

**Table 2. MSP-FET Backchannel UART Implementation**

Target MCLK Frequency:	1 MHz		8 MHz		1 MHz		8 MHz	
Debugger:	Active				Inactive			
Flow Control:	No	Yes	No	Yes	No	Yes	No	Yes
4800 baud	✓	✓	✓	✓	✓	✓	✓	✓
9600 baud	✓	✓	✓	✓	✓	✓	✓	✓
19200 baud	✓	✓	✓	✓	✓	✓	✓	✓
28800 baud	✗	✓	✓	✓	✓	✓	✓	✓
38400 baud	✗	✓	✗	✓	✗	✓	✗	✓
57200 baud	✗	✓	✗	✓	✗	✓	✗	✓
115200 baud	✗	✗	✗	✓	✗	✗	✗	✓

#### 5.6.2.1 UART Backchannel Activation Commands

The MSP-FET supports two different Backchannel UART modes, one with flow control and one without. The different modes can be selected by opening the corresponding COM port with a dedicated baud rate. See [Table 3](#) for the specific baud rates for each command.

---

**NOTE:** The baud rates used by these activation commands cannot be used for communication.

---

**NOTE:** The Backchannel UART is disabled until the COM port is opened with a valid baud rate.

If none of the specified commands are transferred before setting the communication baud rate, communication starts with the default settings: 3.3 V target  $V_{CC}$ , no flow control mechanism.

**Table 3. MSP-FET Backchannel UART Activation Commands**

Baud Rate	Command
9620	Set all backchannel UART pins to high impedance – no current flow into target device
9621	Configure backchannel UART communication without handshake (default start behavior)
9622	Configure backchannel UART communication with handshake
9623	Voltage configuration command. When this command is received, target $V_{CC}$ is set to 3.3 V. After target $V_{CC}$ is configured, it is switched through to the target device.

### 5.6.3 Target BSL Connection and BSL-Scripter Support

The MSP-FET can be used for communication with the target device bootloader (BSL) through the I<sup>2</sup>C and UART protocols. The activation of the different protocols is equivalent to the MSP-FET backchannel UART. See [Table 4](#) for command details.

The BSL-Scripter software in the [zip file](#) that is included with *MSP430™ Programming With the Bootloader (BSL)* ([SLAU319](#)) implements support for these activation commands and performs the correct sequence according to the communication interface (UART, I<sup>2</sup>C) that is specified in the script.

In MSP-FET BSL communication mode, flow control is not available, because this is not supported by the MSP target device BSL.

**UART BSL:** The MSP-FET BSL UART mode supports the following baud rates: 9600, 14400, 19200, 28800, 38400, 56000, 57600, and 115200. For the BSL UART, 8 + 1 + even parity is used.

**I<sup>2</sup>C BSL:** The MSP-FET is always the I<sup>2</sup>C master, and the target device BSL is always the I<sup>2</sup>C slave. 7-bit I<sup>2</sup>C addressing mode is used with a fixed I<sup>2</sup>C slave address of 0x48.

**NOTE:** If the MSP-FET is configured to support BSL communication, debugger functionality is disabled. To switch to debugger mode, either perform a power cycle (unplug the USB cable) or configure the baud rate to 8001. The BSL mode is disabled until sending a BSL entry baud rate command.







Maximum I<sup>2</sup>C clock rate; 55 kHz

**Table 4. MSP-FET MSP Target BSL Activation Commands**















Baud Rate	Command
9620	Set all UART or I <sup>2</sup> C pins to high impedance – no current flow into target device
9601	BSL entry sequence and power up 3.3 V (UART BSL) – debugger is disabled
100000 or 100001	BSL entry sequence and power up 3.3 V (I <sup>2</sup> C BSL) – debugger is disabled
400000 or 400001	BSL entry sequence and power up 3.3 V (I <sup>2</sup> C BSL) – debugger is disabled
9623	Power up 3.3 V
8001	Activate debugger

**NOTE:** The MSP-FET I<sup>2</sup>C interface is a software I<sup>2</sup>C implementation, which always runs with a speed of approximately 55 kHz. The four different speed configurations are supported for compatibility purposes with BSL-Scripter and the BSL-Rocket.

### 5.6.4 LED Signals

The MSP-FET shows its operating states using two LEDs, one green and one red. Table 5 lists all available operation modes. An  or  icon indicates that the LED is off, an  or  icon indicates that the LED is on, and an  or  icon indicates that the LED flashes.

**Table 5. MSP-FET LED Signals**

Power LED	Mode LED	Function
		MSP-FET not connected to PC or MSP-FET not ready; for example, after a major firmware update. Connect or reconnect MSP-FET to PC.
		MSP-FET connected and ready
		MSP-FET waiting for data transfer
		Ongoing data transfer – during active debug session
		An error has occurred; for example, target $V_{CC}$ over current. Unplug MSP-FET from target, and cycle the power off and on. Check target connection, and reconnect MSP-FET.
		Firmware update in progress. Do not disconnect MSP-FET while both LEDs are blinking slowly.
		FPGA update in progress. Do not disconnect MSP-FET while both LEDs are blinking rapidly.

### 5.6.5 Hardware

This section includes MSP-FET hardware descriptions like the JTAG connector, schematics, and power-up states of the MSP-FET JTAG pins.

#### 5.6.5.1 JTAG Target Connector

Figure 12 shows the pinout of the MSP-FET JTAG connector.

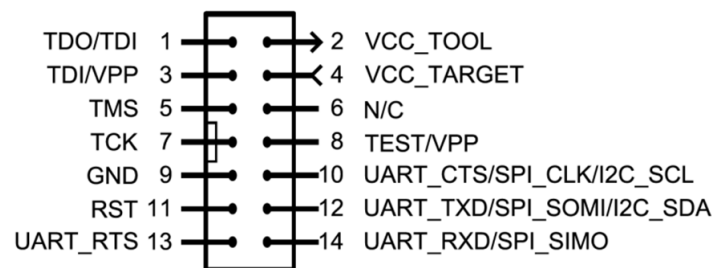

**Figure 12. MSP-FET 14-Pin JTAG Connector**



### 5.6.5.2 MSP-FET Pin States After Power Up

Table 6 describes the electrical state of every JTAG pin after debug probe power up.

**Table 6. MSP-FET Pin States**

Pin	Name	After Power up	When JTAG Protocol is Active	When Spy-Bi-Wire Protocol is Active
1	TDO/TDI	Hi-Z, pulled up to 3.3 V	In, TDO	In and Out, SBWTDIO (RST pin)
2	VCC_TOOL	3.3 V	Target V <sub>CC</sub>	Target V <sub>CC</sub>
3	TDI/VPP	Hi-Z, pulled up to 3.3 V	Out, TDI	Hi-Z, pulled up to V <sub>CC</sub>
4	VCC_TARGET	In, external V <sub>CC</sub> sense	In, external V <sub>CC</sub> sense	In, external V <sub>CC</sub> sense
5	TMS	Hi-Z, pulled up to 3.3 V	Out, TMS	Hi-Z, pulled up to V <sub>CC</sub>
6	N/C	N/C	N/C	N/C
7	TCK	Hi-Z, pulled up to 3.3 V	Out, TCK	Out, SBWTCK
8	TEST/VPP	Out, Ground	Out, TEST	Hi-Z, pulled up to V <sub>CC</sub>
9	GND	Ground	Ground	Ground
10	UART_CTS/SPI_CLK/I2C_SCL	Hi-Z, pulled up to 3.3 V	Out, Target UART Clear-To-Send Handshake input	Out, Target UART Clear-To-Send Handshake input
11	RST	Out, V <sub>CC</sub>	Out, RST	Ground
12	UART_TXD/SPI_SOMI/I2C_SDA	Hi-Z, pulled up to 3.3 V	In, Target UART TXD output	In, Target UART TXD output
13	UART_RTS	Hi-Z, pulled up to 3.3 V	In, Target UART Ready-to-Send Handshake output	In, Target UART Ready-to-Send Handshake output
14	UART_RXD/SPI_SIMO	Hi-Z, pulled up to 3.3 V	Out, Target UART RXD input	Out, Target UART RXD input

---

**NOTE:** To enable the UART, I<sup>2</sup>C or SPI pins, the correct invalid baud rate activation command must be sent (see MSP-FET Backchannel UART Activation Commands and MSP-FET MSP Target BSL Activation Commands). After this the pins switch into the state described in the [Table 6](#).

---



---

**NOTE:** MSP430BSL-SPI support is currently not available using the MSP-FET. The pin names used in [Table 6](#) are the same as the names that are printed on the back of the MSP-FET.

---

5.6.5.3 Schematics

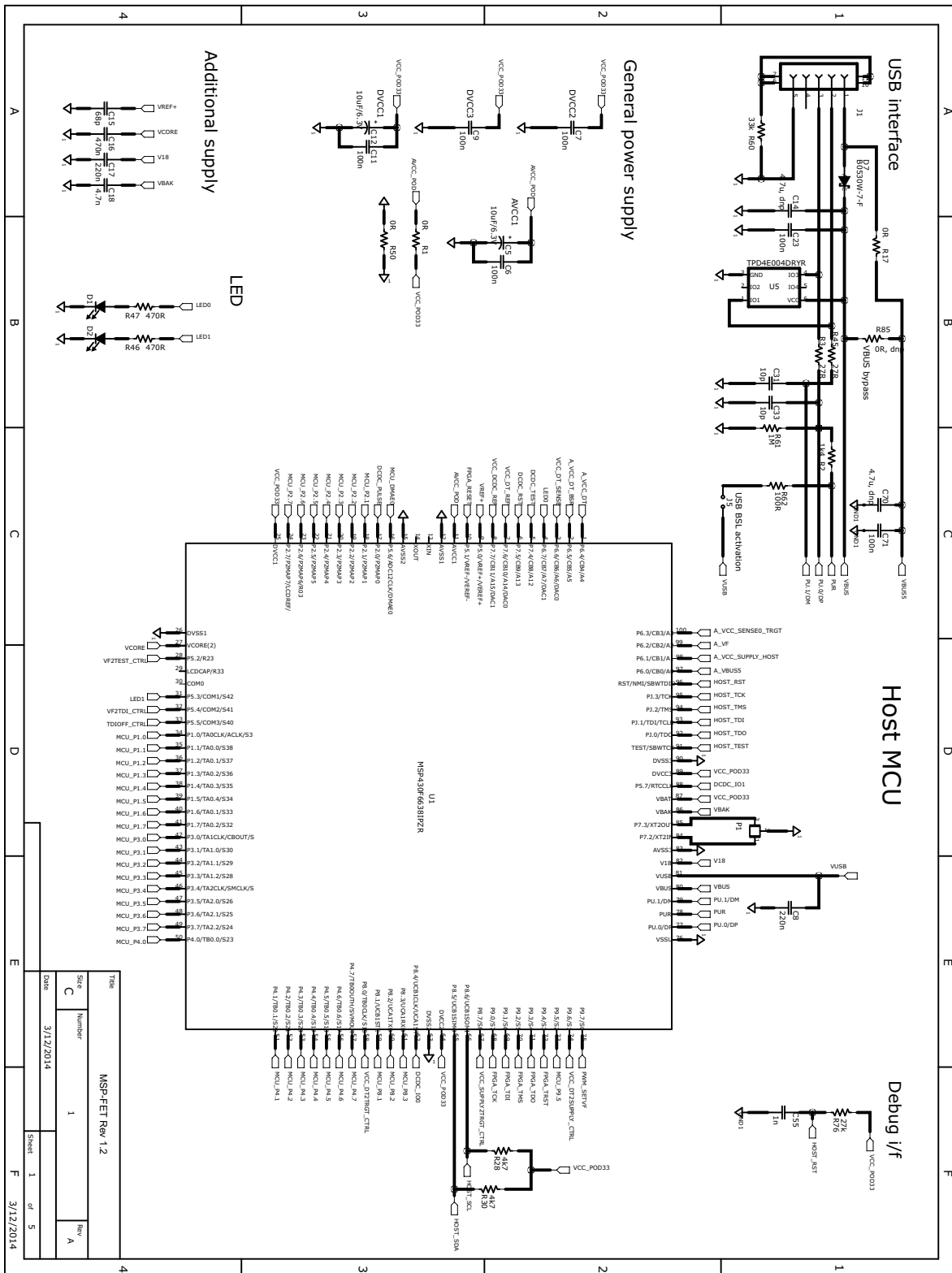

Figure 13. MSP-FET USB Debugger, Schematic (1 of 5)

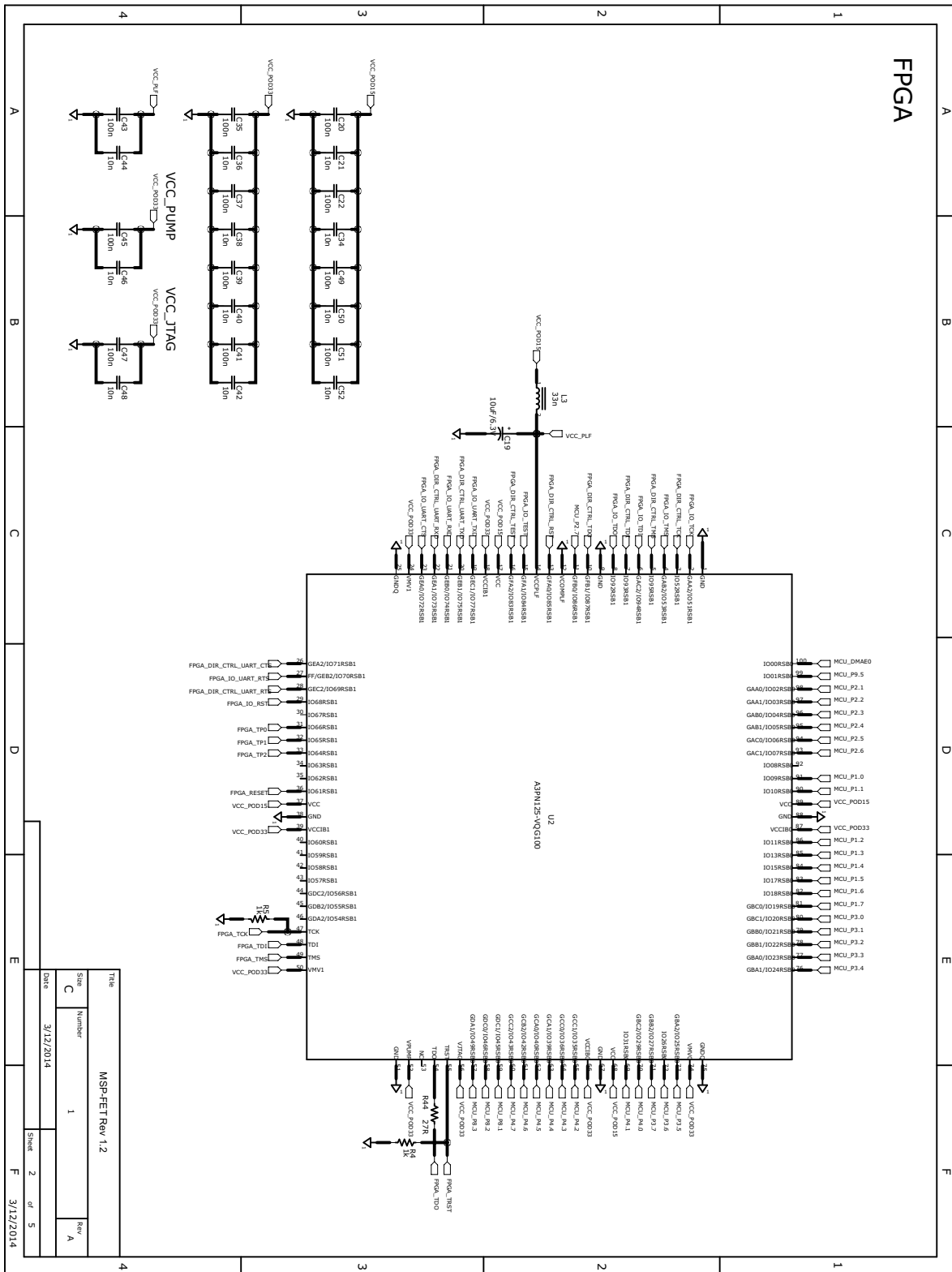

Figure 14. MSP-FET USB Debugger, Schematic (2 of 5)

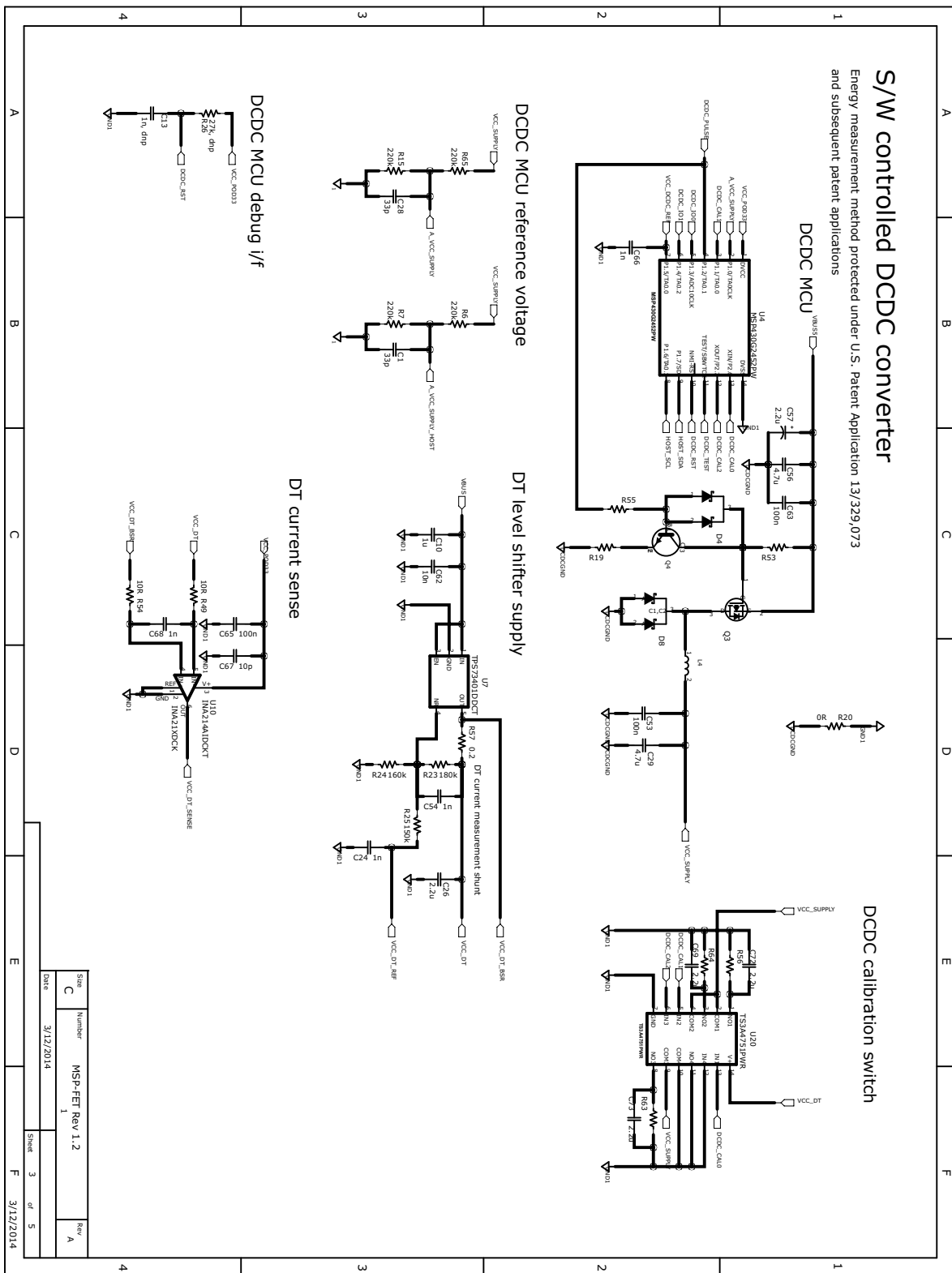

Figure 15. MSP-FET USB Debugger, Schematic (3 of 5)

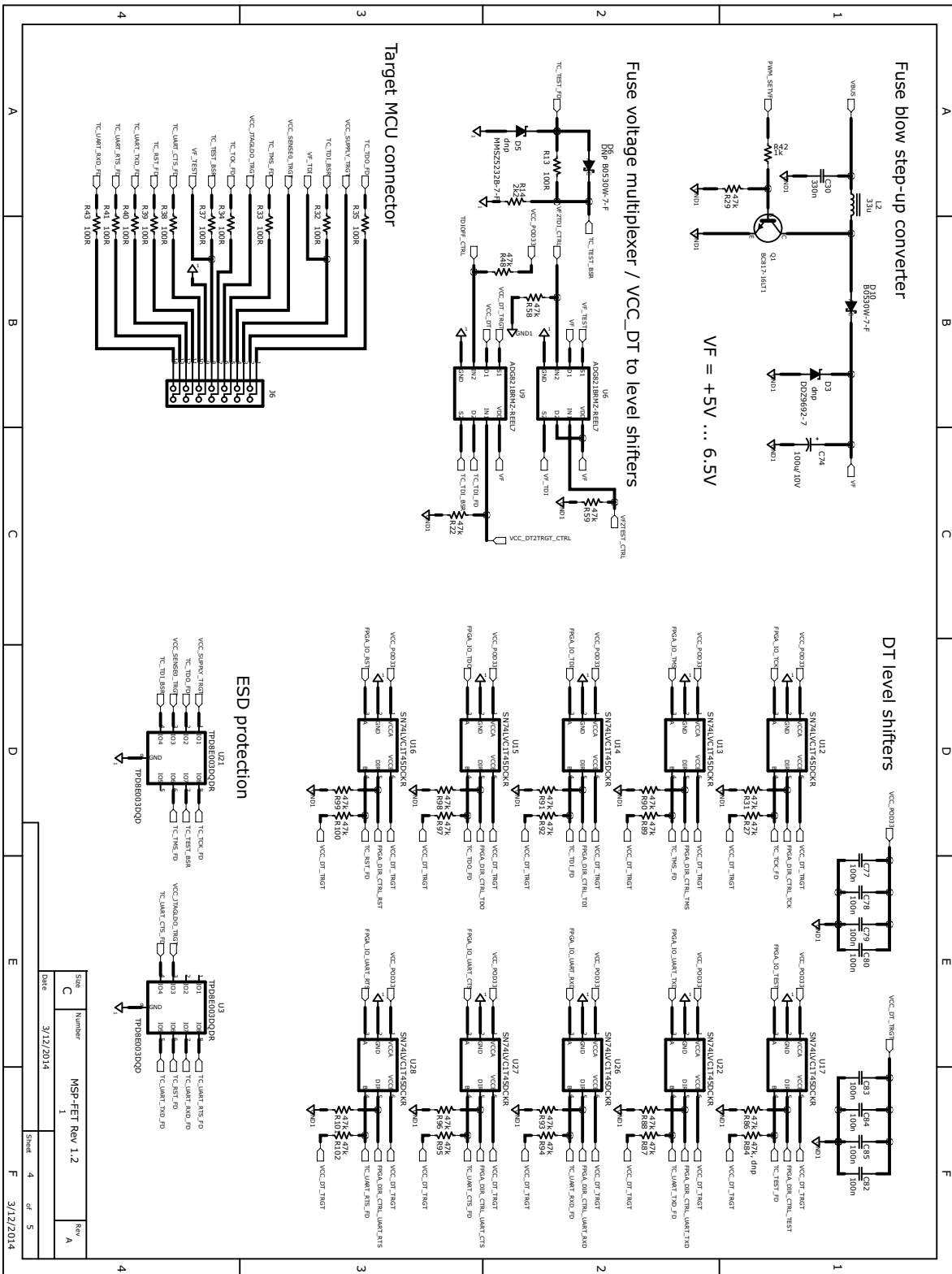

Figure 16. MSP-FET USB Debugger, Schematic (4 of 5)

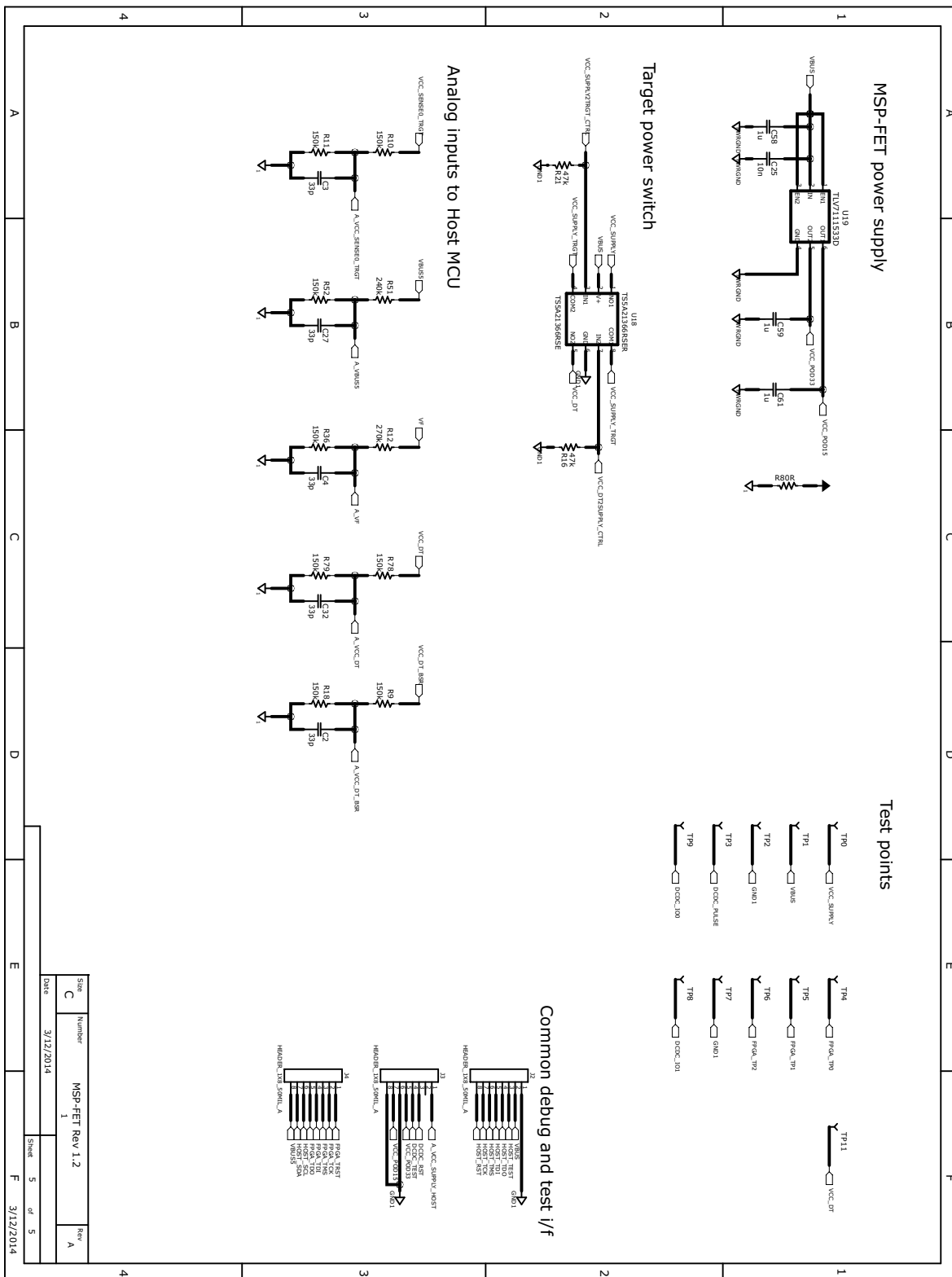

Figure 17. MSP-FET USB Debugger, Schematic (5 of 5)

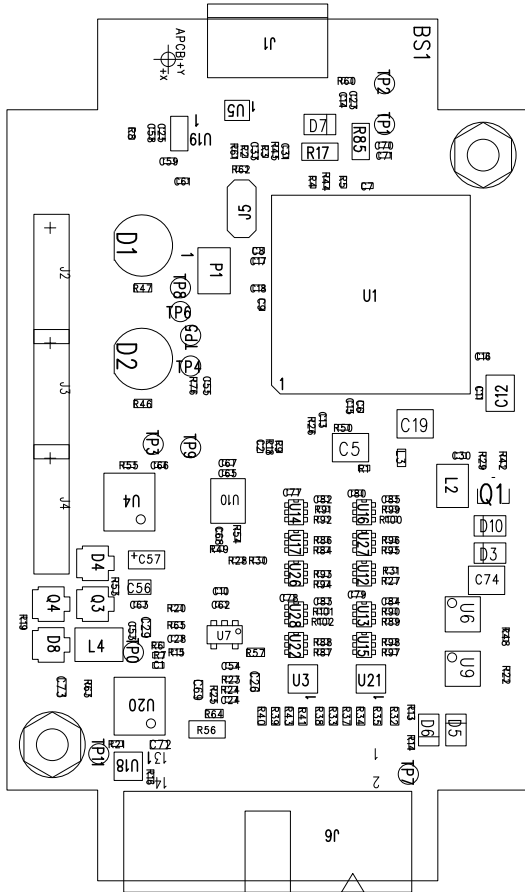

Figure 18. MSP-FET USB Debugger, PCB (Top)

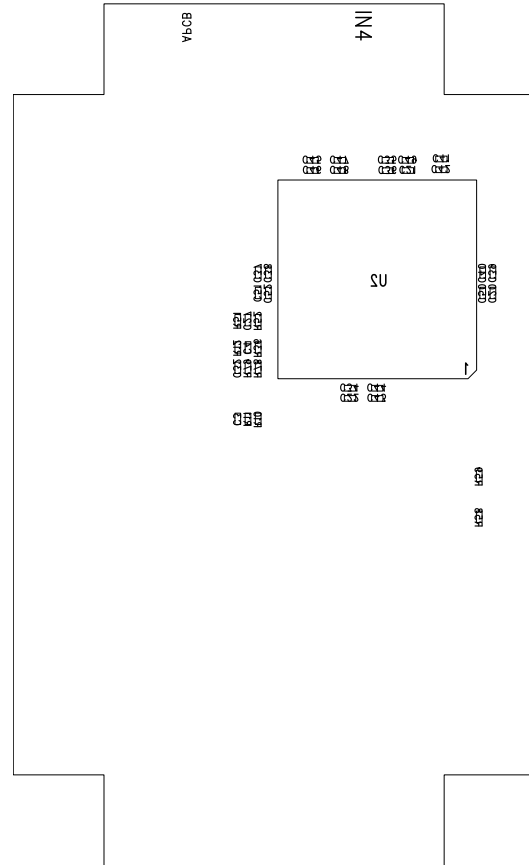

Figure 19. MSP-FET USB Debugger, PCB (Bottom)

## 5.7 MSP-FET430UIF Stand-Alone Debugger

The MSP-FET430UIF is a powerful debug probe for application development on MSP430 microcontrollers. This is a legacy debugger being replaced by MSP-FET.

The MSP-FET430UIF provides a USB interface to program and debug the MSP430 devices in-system through the JTAG interface or the pin-saving Spy-Bi-Wire (2-wire JTAG) protocol.

The MSP-FET430UIF development tool supports development with all MSP430 devices and is designed for use with PCBs that contain MSP430 devices; for example, the MSP430 target socket boards.

Two different version of the MSP-FET430UIF are available, version 1.3 and version 1.4a. There are limitations when using version 1.3. Refer to [Section 5.7.1](#) for more details.



Figure 20. MSP-FET430UIF Version 1.4a Top and Bottom Views



Figure 21. MSP-FET430UIF Version 1.3 Top and Bottom Views

### 5.7.1 General Features

The following features are provided by the MSP-FET430UIF debug probe.

Features:

- Operating systems: OS X, Linux, Windows
- Software configurable supply voltage between 1.8 V and 3.6 V at 100 mA
- External voltage detection
- Supports JTAG Security Fuse blow to protect code
- Supports all MSP430 boards with JTAG header
- Supports both JTAG and Spy-Bi-Wire (2-wire JTAG) debug protocols
- Software breakpoints in Flash, FRAM, and RAM support
- Flash and FRAM programming support
- Software field update is possible (enable new device support by in field firmware updates)







---

**NOTE:** The MSP-FET430UIF version 1.3 does not support Spy-Bi-Wire connection for MSP430 devices with 1- $\mu$ F capacitance on the reset line.













---



## 5.7.2 LED Signals

The MSP-FET430UIF shows its operating states using two LEDs, one green and one red. [Table 7](#) lists all available operation modes. An  or  icon indicates that the LED is off, an  or  icon indicates that the LED is on, and an  or  icon indicates that the LED flashes.

**Table 7. MSP-FET430UIF LED Signals**

Power LED	Mode LED	Function
		MSP-FET430UIF not connected to PC, or MSP-FET430UIF not ready; for example, after a major firmware update. Connect or reconnect MSP-FET430UIF to PC.
		MSP-FET430UIF connected and ready
		MSP-FET430UIF waiting for data transfer
		Ongoing data transfer – during active debug session
		An error has occurred; for example, target $V_{CC}$ over current. Unplug MSP-FET430UIF from target, and cycle the power off and on. Check target connection, and reconnect MSP-FET430UIF.
		Firmware update in progress. Do not disconnect MSP-FET430UIF while both LEDs are blinking.

## 5.7.3 Hardware

This section includes MSP-FET430UIF hardware descriptions like the JTAG connector, schematic, and power up states of the JTAG pins.

### 5.7.3.1 JTAG Target Connector

[Figure 22](#) shows the pinout of the MSP-FET430UIF JTAG connector.

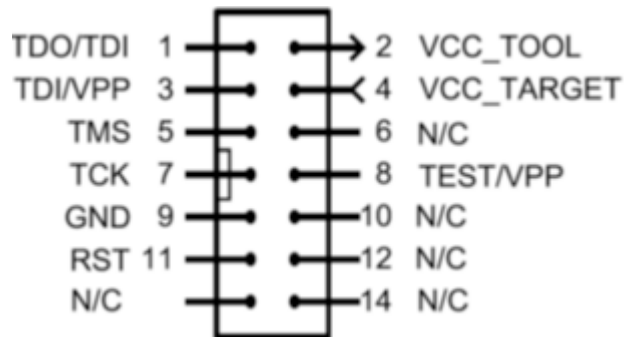

**Figure 22. MSP-FET430UIF 14-Pin JTAG Connector**

### 5.7.3.2 Pin States After Power Up

Table 8 describes the electrical state of every JTAG pin after debug probe power up.

**Table 8. MSP-FET430UIF Pin States**

Pin	Name	After Power-Up	When JTAG Protocol is Active	When Spy-Bi-Wire Protocol is Active
1	TDO/TDI	Hi-Z, pulled up to 3.3 V	In, TDO	In and Out, SBWTDIO
2	VCC_TOOL	3.3 V	Target V <sub>CC</sub>	Target V <sub>CC</sub>
3	TDI/VPP	Hi-Z, pulled up to 3.3 V	Out, TDI	Hi-Z, pulled up to V <sub>CC</sub>
4	VCC_TARGET	In, external V <sub>CC</sub> sense	In, external V <sub>CC</sub> sense	In, external V <sub>CC</sub> sense
5	TMS	Hi-Z, pulled up to 3.3 V	Out, TMS	Hi-Z, pulled up to V <sub>CC</sub>
6	N/C	N/C	N/C	N/C
7	TCK	Hi-Z, pulled up to 3.3 V	Out, TCK	Out, SBWTCK
8	TEST/VPP	Out, Ground	Out, TEST	Hi-Z, pulled up to V <sub>CC</sub>
9	GND	Ground	Ground	Ground
10	N/C	N/C	N/C	N/C
11	RST	Out, V <sub>CC</sub>	Out, RST	Ground
12	N/C	N/C	N/C	N/C
13	N/C	N/C	N/C	N/C
14	N/C	N/C	N/C	N/C



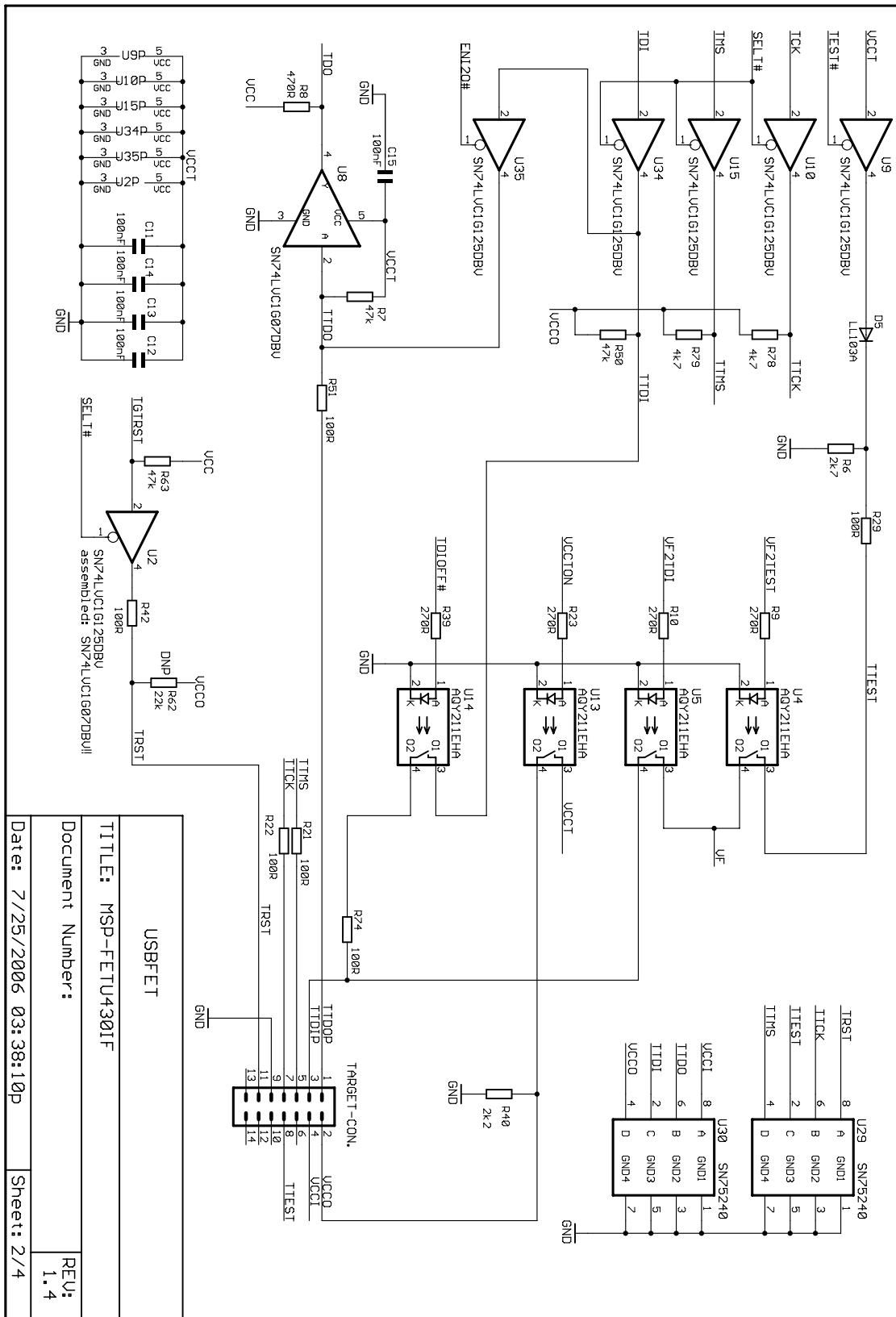

Figure 24. MSP-FET430UIF USB Interface, Schematic (2 of 4)

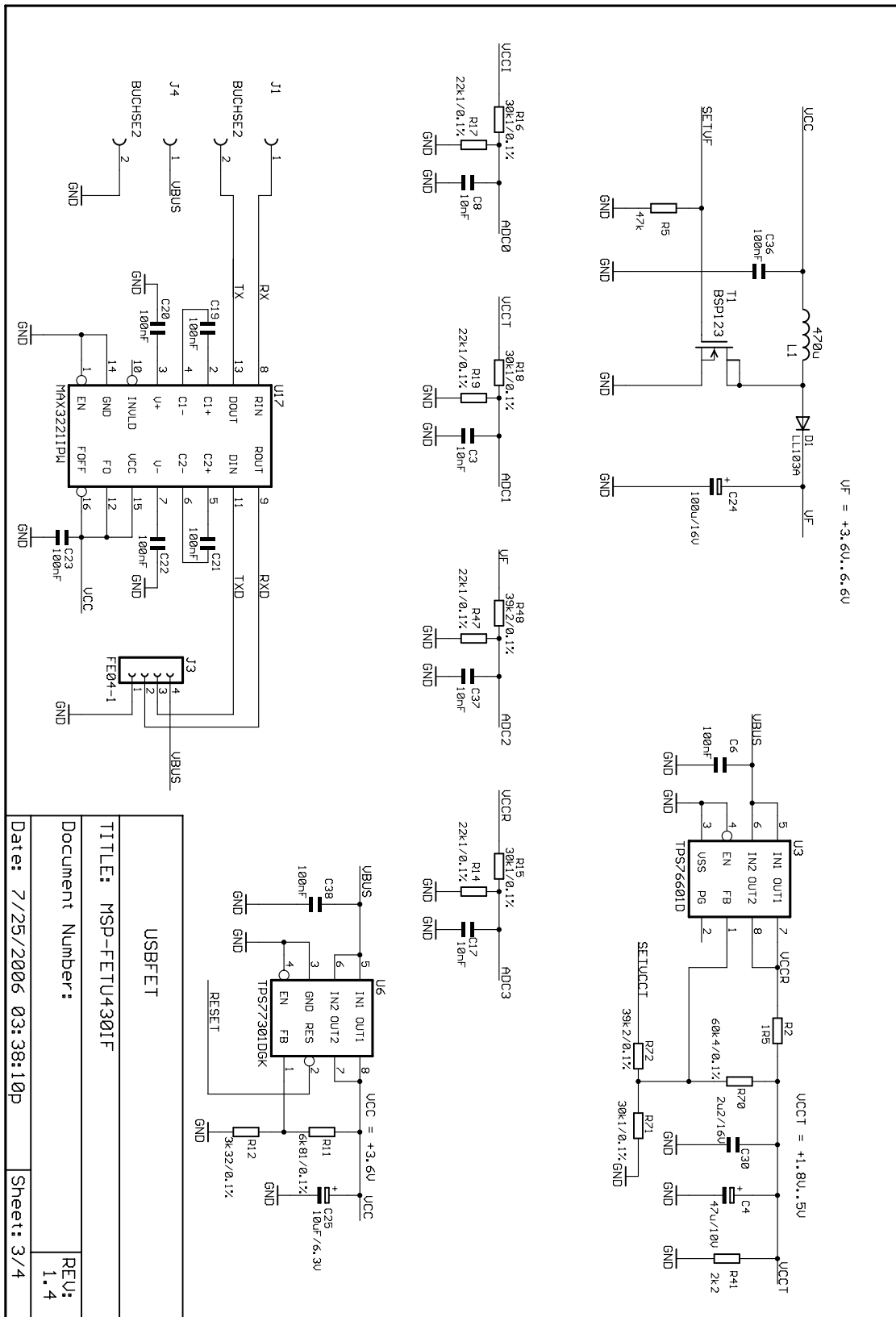

Figure 25. MSP-FET430UIF USB Interface, Schematic (3 of 4)

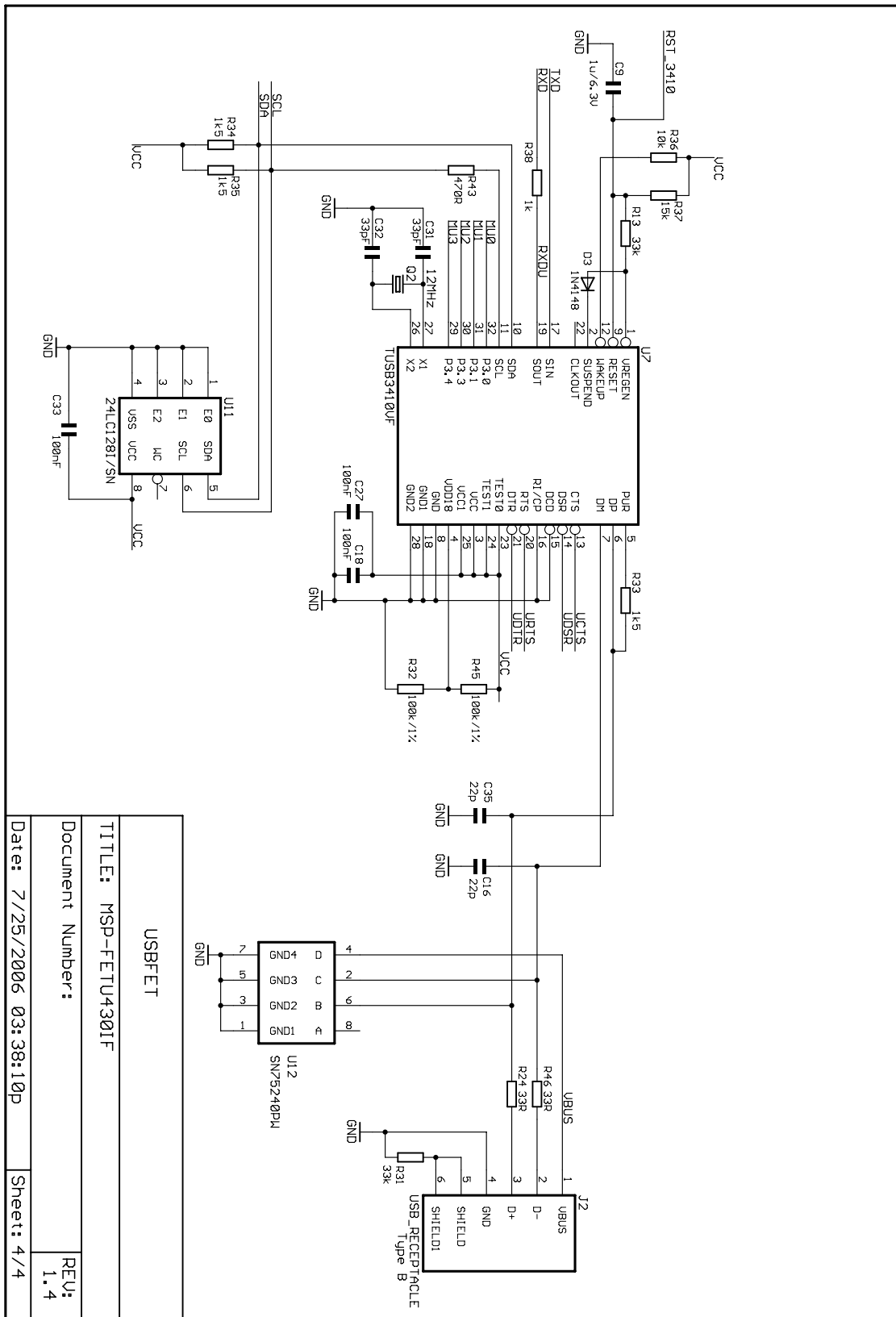

Figure 26. MSP-FET430UIF USB Interface, Schematic (4 of 4)

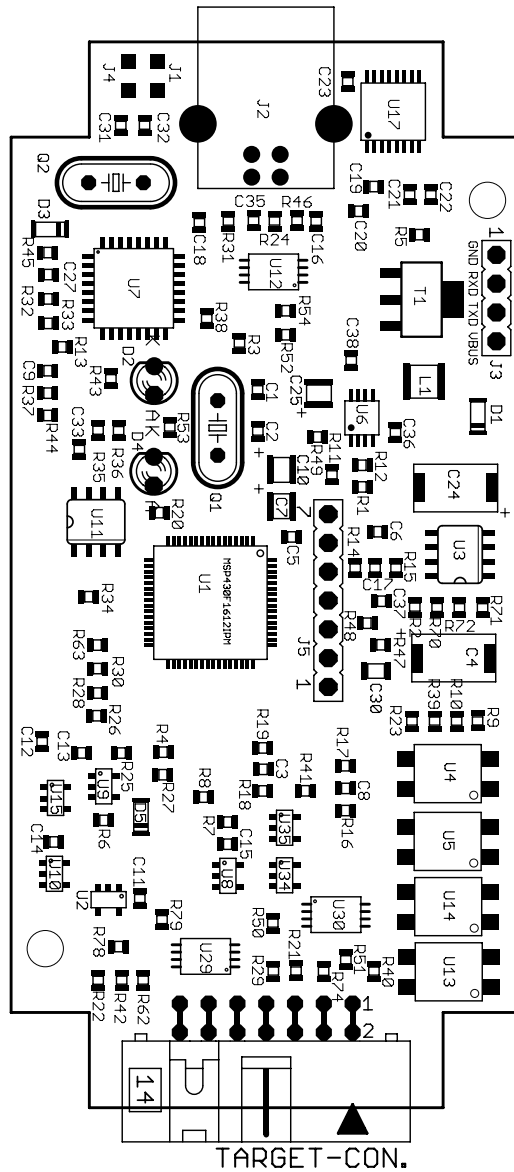

Figure 27. MSP-FET430UIF USB Interface, PCB

## 5.8 eZ-FET and eZ-FET Lite Onboard Emulation

The eZ-FET and eZ-FET Lite are powerful onboard flash emulation debug probes for application development on MSP430 microcontrollers. The eZ-FET and eZ-FET Lite onboard emulation are the successors of the legacy eZ430.

Both eZ-FETs provide a USB interface to program and debug the MSP430 devices in-system through the pin-saving Spy-Bi-Wire (2-wire JTAG) protocol. Furthermore, the USB interface can be used for Backchannel UART communication.

Both development tools support development with all MSP430 devices. They are designed as onboard emulation that is available on several LaunchPad kits. <sup>(1)</sup>

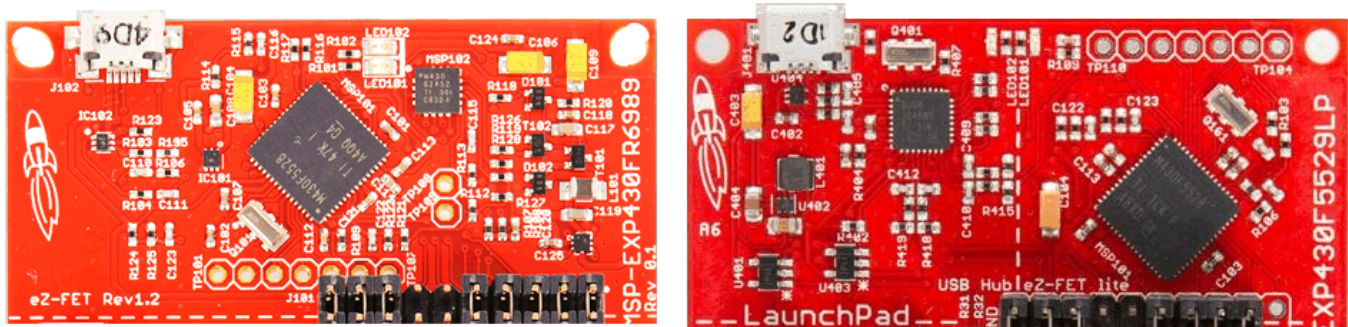

Figure 28. eZ-FET and eZ-FET Lite Top Views

### 5.8.1 General Features

The following features are provided by the eZ-FET and eZ-FET Lite debug probes.

Features:

- Operating systems: OS X, Linux, Windows
- Fixed supply voltage between 3.3 or 3.6 V at 75 mA
- Support Spy-Bi-Wire (2-wire JTAG) debug protocol
- Software Breakpoint in Flash, FRAM, and RAM support
- Flash and FRAM programming support
- Backchannel UART
- eZ-FET only – EnergyTrace and EnergyTrace++ support
- Software field update is possible

<sup>(1)</sup> Only MSP430 devices that implement the SBW2 protocol are supported



## 5.8.2 Backchannel UART

Supported baud rates depend on the target configuration and the debug settings. [Table 9](#) shows which baud rates are supported with certain configuration combinations.

✓ means that the corresponding baud rate is supported without any data loss with the specified combination of settings.

✗ means that the corresponding baud rate is not supported (data loss is expected) with the specified combination of settings.

**Table 9. eZ-FET and eZ-FET Lite Backchannel UART Implementation**

Target MCLK Frequency:	1 MHz		8 MHz		1 MHz		8 MHz	
Debugger:	Active				Inactive			
Flow Control:	No	Yes	No	Yes	No	Yes	No	Yes
4800 baud	✓	✓	✓	✓	✓	✓	✓	✓
9600 baud	✓	✓	✓	✓	✓	✓	✓	✓
19200 baud	✓	✓	✓	✓	✓	✓	✓	✓
28800 baud	✗	✓	✓	✓	✓	✓	✓	✓
38400 baud	✗	✓	✗	✓	✗	✓	✗	✓
57200 baud	✗	✓	✗	✓	✗	✓	✗	✓
115200 baud	✗	✗	✗	✓	✗	✗	✗	✓

### 5.8.2.1 eZ-FET and eZ-FET Lite UART Backchannel Activation Commands

The eZ-FET supports two different backchannel UART modes, one with flow control and one without. The different modes can be selected by opening the corresponding COM port with a dedicated baud rate. See [Table 10](#) for the specific baud rates for each command.

---

**NOTE:** The baud rates used by these commands cannot be used for communication.







---

If none of the specified commands are transferred before setting the communication baud rate, communication starts with these default settings:  $V_{CC}$  on, no flow control mechanism.













**Table 10. eZ-FET and eZ-FET Lite Backchannel UART Activation Commands**

Baud Rate	Command
9620	Set all backchannel UART pins to high impedance – no current flow into target device
9621	Configure backchannel UART communication without handshake (default start behavior)
9622	Configure backchannel UART communication with handshake
9623	Voltage configuration command. When this command is received, target $V_{CC}$ switched on.

### 5.8.3 LED Signals

eZ-FET emulators show their operating states using two LEDs, one green and one red. Table 11 lists all available operation modes. An  or  icon indicates that the LED is off, an  or  icon indicates that the LED is on, and an  or  icon indicates that the LED flashes.

**Table 11. eZ-FET LED Signals**

Power LED	Mode LED	Function
		eZ-FET not connected to PC, or eZ-FET not ready; for example, after a major firmware update. Connect or reconnect eZ-FET to PC.
		eZ-FET connected and ready
		eZ-FET waiting for data transfer
		Ongoing data transfer – during active debug session
		An error has occurred; for example, target $V_{CC}$ over current. Unplug eZ-FET from target, and cycle the power off and on. Check target connection, and reconnect eZ-FET.
		Firmware update in progress. Do not disconnect eZ-FET while both LEDs are blinking.

### 5.8.4 Hardware

This section describes the pinout of the eZ-FET and eZ-FET Lite debug connector. It includes a list of all debugger pin states after power up and the eZ-FET and eZ-FET Lite schematics.

#### 5.8.4.1 JTAG Target Connector

Figure 29 shows the pinout of the eZ-FET debug connector.



**Figure 29. eZ-FET or eZ-FET Lite Debug Connector**

### 5.8.4.2 Connecting MSP-FET to LaunchPad

Figure 30 and Figure 31 show how to connect an MSP-FET to the target MSP430 device that is solders onto the LaunchPad, using an F5529 LaunchPad as an example.

MSP-FET		'F5529 Launchpad (Isolation Jumper Block)	
Signal	Pin	Signal	Pin
GND	9	GND	JP3
VCC_TOOL	2	3V3	JP2
TDO/TDI	1	SBW_RST	JP4.2
TCK	7	SBW_TST	JP4.1

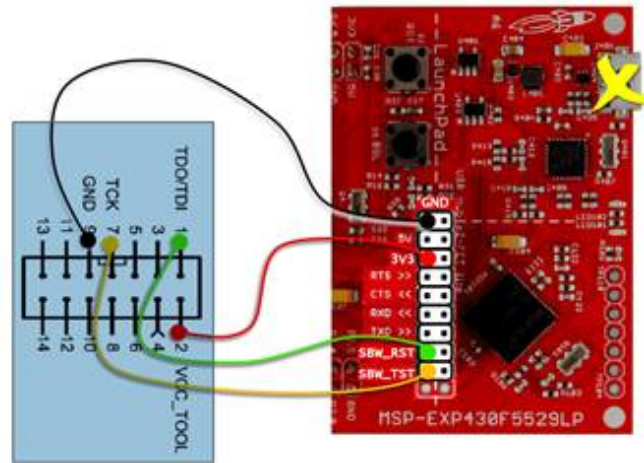

Figure 30. MSP-FET to LaunchPad Pin Assignments

Figure 31. MSP-FET to LaunchPad Wiring Diagram

### 5.8.4.3 Pin States After Power Up

Table 12 describes the electrical state of every JTAG pin after debug probe power up.

Table 12. eZ-FET and eZ-FET Lite Pin States

Signal Name	After Power-Up	When Spy-Bi-Wire Protocol is Active
SBWTDIO	Hi-Z, pulled up to 3.3 V	In and Out, SBWTDIO
SBWTCK	Hi-Z, pulled up to 3.3 V	Out, SBWTCK
TXD	Hi-Z, pulled up to 3.3 V	In, Target UART TXD output
RXD	Hi-Z, pulled up to 3.3 V	Out, Target UART RXD input
CTS	Hi-Z, pulled up to 3.3 V	Out, Target UART Clear-To-Send Handshake input
RTS	Hi-Z, pulled up to 3.3 V	In, Target UART Ready-to-Send Handshake output
3V3	Target V <sub>CC</sub>	Target V <sub>CC</sub>
5V	USB V <sub>CC</sub>	USB V <sub>CC</sub>
GND	Ground	Ground

5.8.4.4 Schematics

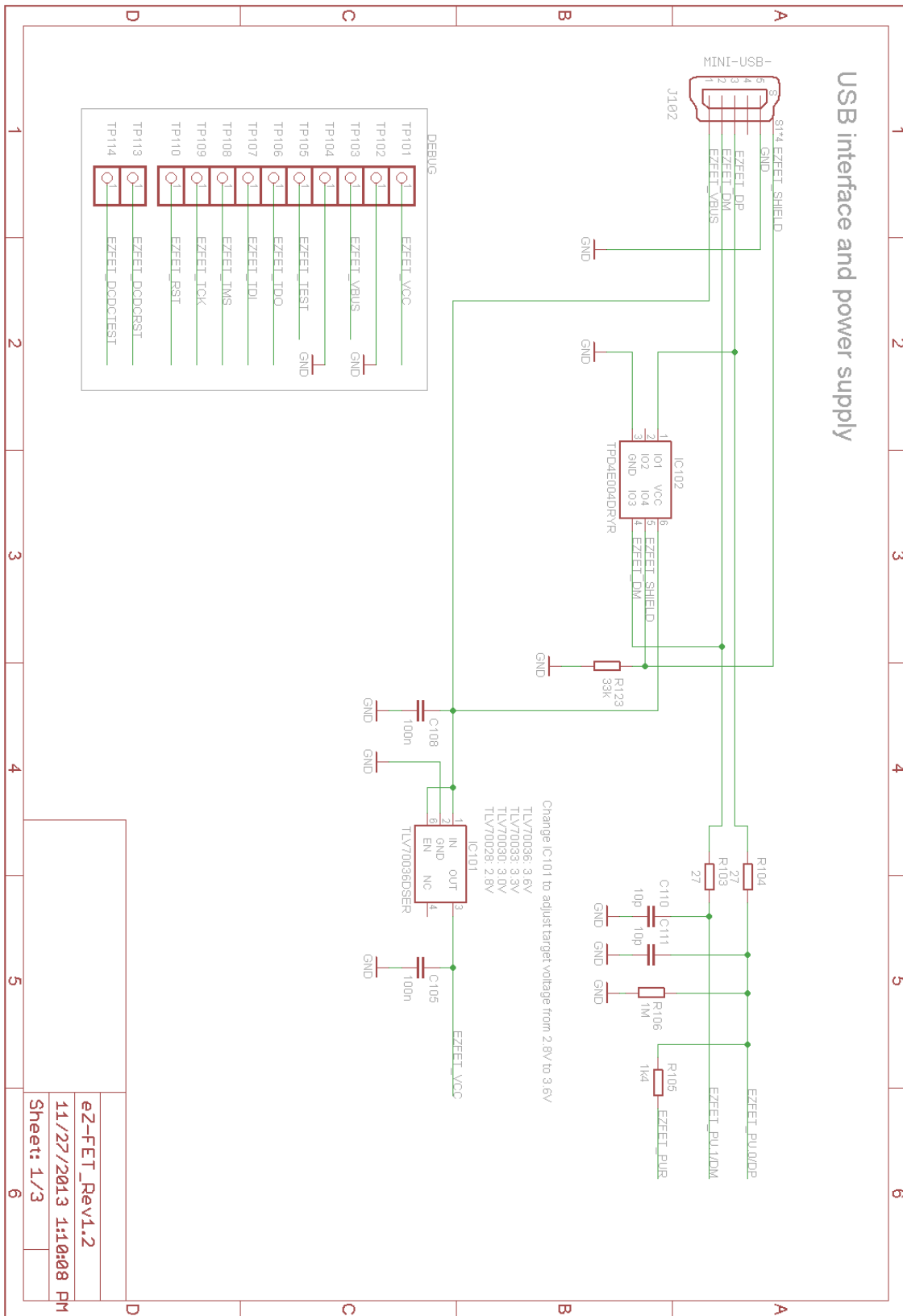

Figure 32. eZ-FET Schematic (USB Connection)

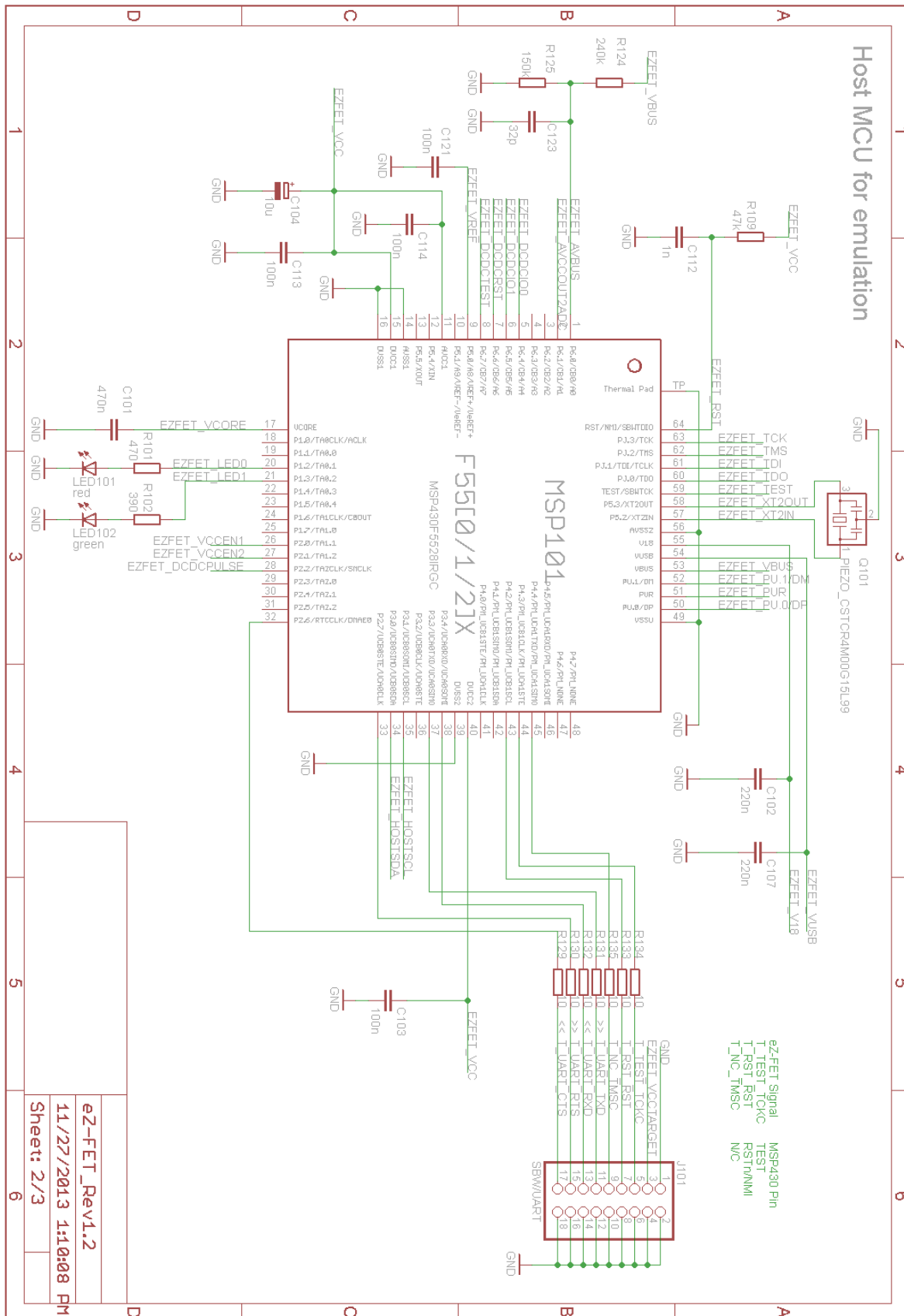

Figure 33. eZ-FET Schematic (Emulation MCU)

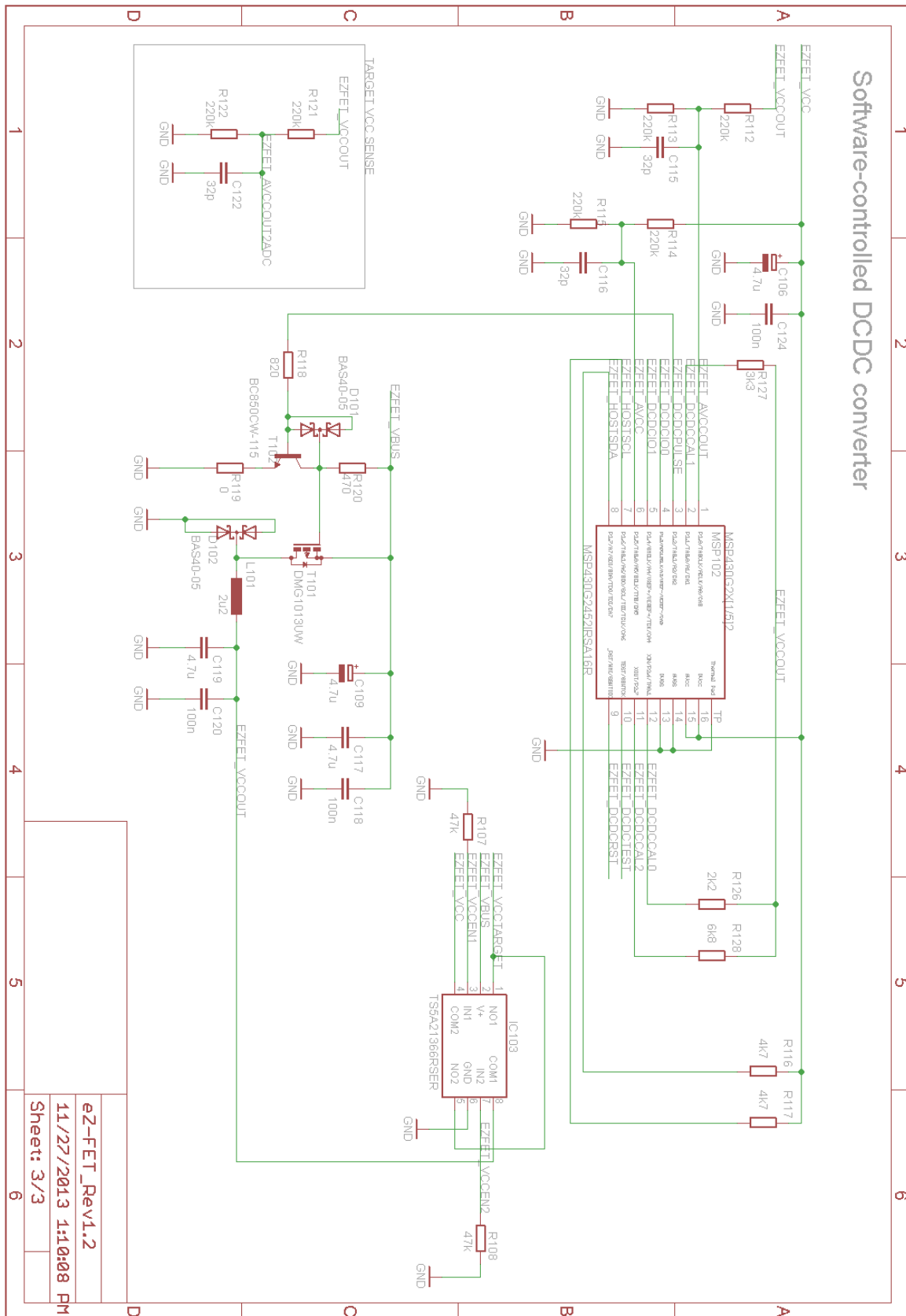

Figure 34. eZ-FET Schematic DCDC (No eZ-FET Lite)

## 5.9 eZ430 Onboard Emulation

The eZ430 onboard emulation is the legacy onboard flash emulation for application development on MSP430 microcontrollers. The eZ-FET and eZ-FET Lite onboard emulation are the successors of the legacy eZ430.

The eZ430 provides a USB interface to program and debug the MSP430 devices in-system through the pin-saving Spy-Bi-Wire (2-wire JTAG) protocol. Furthermore, the USB interface can be used for Backchannel UART communication.

---

**NOTE:** The eZ430 does not support all MSP430 device families. Refer to [Table 1](#) for more details about device support.

---



**Figure 35. eZ430 Emulation**

### 5.9.1 General Features

USB debug interface to connect a MSP430 MCU to a PC for real-time in-system programming and debugging.

Features:

- Operating systems: Windows
- Fixed supply voltage between 3.6 V at 75 mA
- Support Spy-Bi-Wire (2-wire JTAG) debug protocol
- Software Breakpoint in Flash, FRAM, and RAM support
- Flash and FRAM programming support
- Backchannel UART
- Software field update is **not** possible (refer to [Table 1](#) for device support details)
- Limited device support

### 5.9.2 Backchannel UART

The baud rates that are supported depend on the target configuration and the debug settings. [Table 13](#) shows which baud rates are supported with certain configuration combinations.

✓ means that the corresponding baud rate is supported without any data loss with the specified combination of settings.

✗ means that the corresponding baud rate is not supported (data loss is expected) with the specified combination of settings.

**Table 13. eZ430 Backchannel UART Implementation**

Target MCLK Frequency:	1 MHz	8 MHz
Debugger:	Active	Active
4800 baud	✓	✓
9600 baud	✓	✓
19200 baud	✗	✗
28800 baud	✗	✗
38400 baud	✗	✗
57200 baud	✗	✗
115200 baud	✗	✗

### 5.9.3 Hardware

This section describes the pinout of the eZ430 debug connector. It includes a list of all debugger pin states after power up and the ez430 schematics.

#### 5.9.3.1 JTAG Target Connector

[Figure 36](#) shows the pinout of the eZ430 debug connector.



**Figure 36. eZ430 Debug Connector on MSP-EXP430G2 LaunchPad**

#### 5.9.3.2 Pin States After Power Up

[Table 14](#) describes the electrical state of every JTAG pin after debug probe power up.

**Table 14. eZ430 Pin States**

Signal Name	After Power-Up	When Spy-Bi-Wire Protocol is Active
VCC	Target V <sub>CC</sub>	Target V <sub>CC</sub>
RST	In and Out, SBWTDIO	In and Out, SBWTDIO
TST	Out, SBWTCK	Out, SBWTCK
TXD	In, Target UART TXD output	In, Target UART TXD output
RXD	Out, Target UART RXD input	Out, Target UART RXD input



5.9.3.3 Schematics

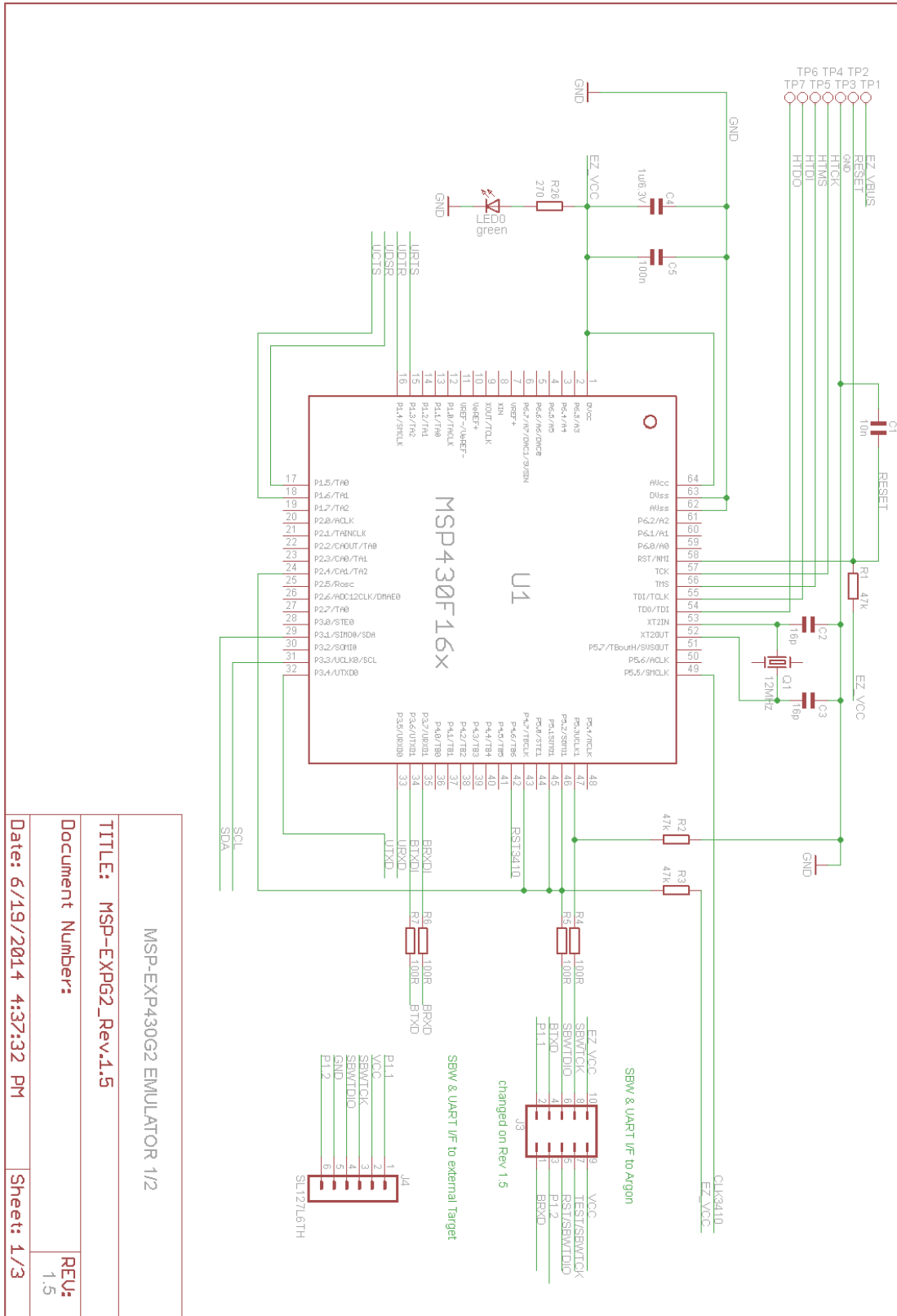

Figure 37. eZ430 Schematic (Emulation MCU)

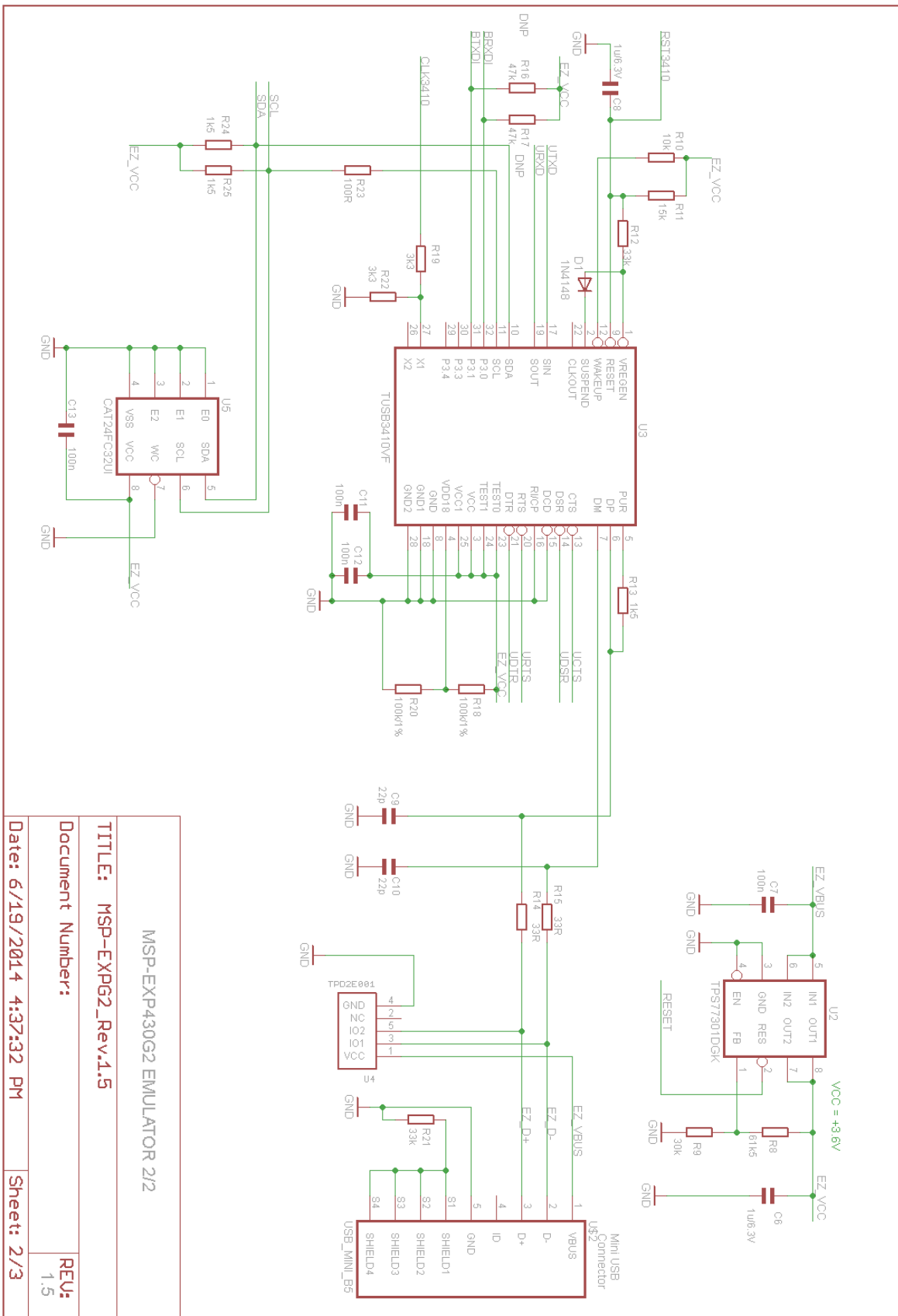
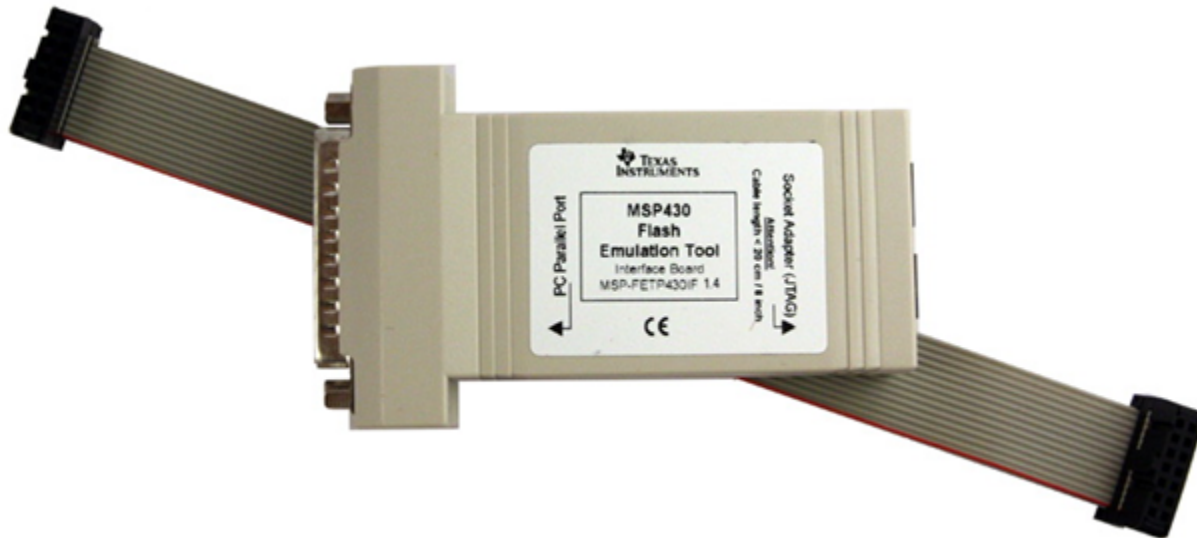

Figure 38. eZ430 Schematic (USB Connection)

## 5.10 MSP-FET430PIF

The MSP-FET430PIF is a parallel port interface that is used to program and debug MSP430 boards through the JTAG interface. This interface uses a parallel PC port to communicate with the IDE (CCS, EW430, or the MSP Flasher) running on the PC. The interface uses the standard 14-pin JTAG header to communicate with the MSP430 device using the standard JTAG protocol.

The flash memory can be erased and programmed in seconds with only a few keystrokes, and because the MSP430 flash is extremely low power, no external power supply is required. The tool has an integrated software environment and connects directly to the PC which greatly simplifies the setup and use of the tool.



**Figure 39. MSP-FET430PIF**

### 5.10.1 General Features

- Operating systems: Windows XP
- Fixed supply voltage between 3.3 V at 25 mA
- Software Breakpoint in Flash, FRAM, and RAM support
- Flash and FRAM programming support
- Supports JTAG protocol only <sup>(1)</sup>

---

**NOTE:** The MSP-FET430PIF is for legacy device support only. This emulation tool does not support any devices released after 2011.

---

<sup>(1)</sup> Spy-Bi-Wire (2-wire JTAG) is supported

5.10.2 Schematics

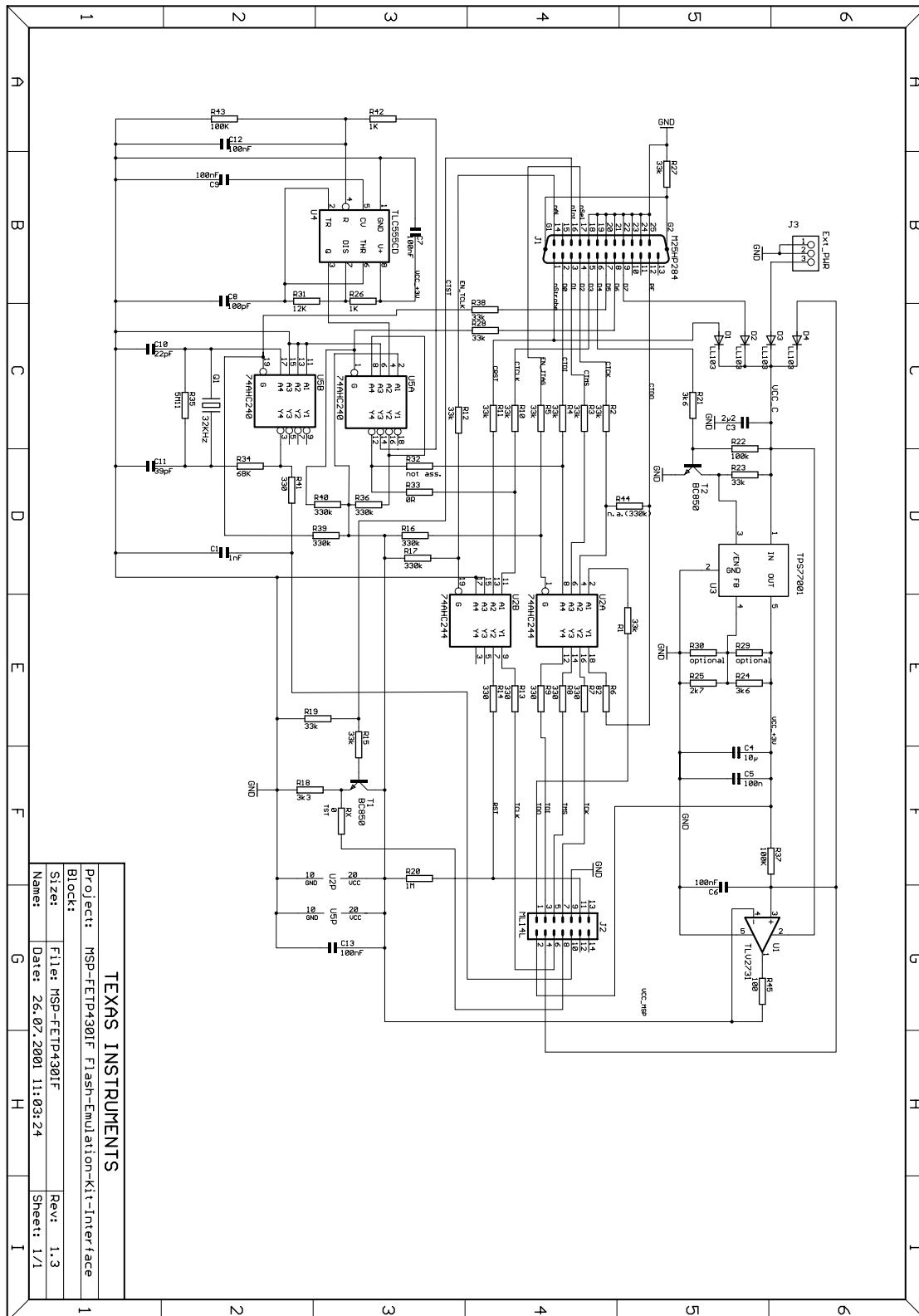

Figure 40. MSP-FET430PIF FET Interface Module, Schematic

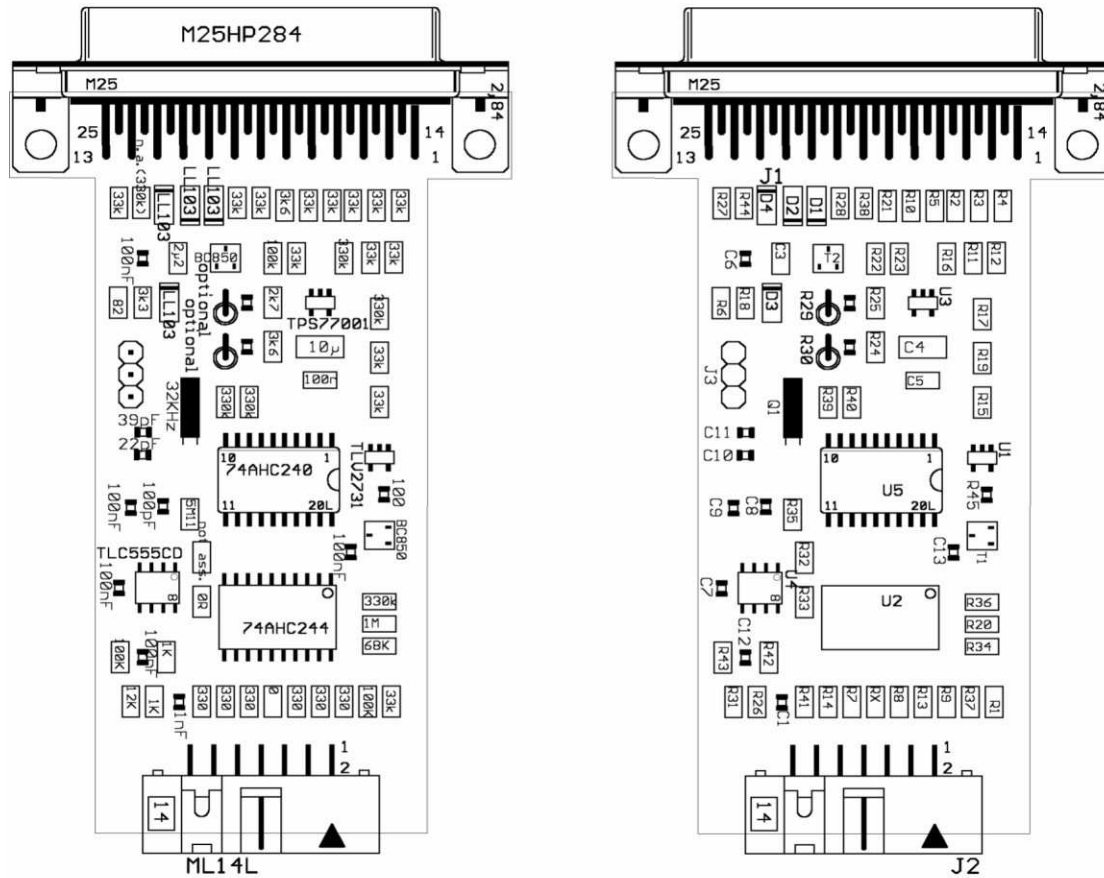

Figure 41. MSP-FET430PIF FET Interface Module, PCB

---

## Revision History

<b>Changes from September 12, 2015 to November 2, 2015</b>	<b>Page</b>
• Changed all instances of "bootstrap loader" to "bootloader" .....	<b>3</b>
• Removed "beta support" from "Windows 10 32-bit or 64-bit" (now fully supported) .....	<b>8</b>

---

NOTE: Page numbers for previous revisions may differ from page numbers in the current version.

## IMPORTANT NOTICE

Texas Instruments Incorporated and its subsidiaries (TI) reserve the right to make corrections, enhancements, improvements and other changes to its semiconductor products and services per JESD46, latest issue, and to discontinue any product or service per JESD48, latest issue. Buyers should obtain the latest relevant information before placing orders and should verify that such information is current and complete. All semiconductor products (also referred to herein as "components") are sold subject to TI's terms and conditions of sale supplied at the time of order acknowledgment.

TI warrants performance of its components to the specifications applicable at the time of sale, in accordance with the warranty in TI's terms and conditions of sale of semiconductor products. Testing and other quality control techniques are used to the extent TI deems necessary to support this warranty. Except where mandated by applicable law, testing of all parameters of each component is not necessarily performed.

TI assumes no liability for applications assistance or the design of Buyers' products. Buyers are responsible for their products and applications using TI components. To minimize the risks associated with Buyers' products and applications, Buyers should provide adequate design and operating safeguards.

TI does not warrant or represent that any license, either express or implied, is granted under any patent right, copyright, mask work right, or other intellectual property right relating to any combination, machine, or process in which TI components or services are used. Information published by TI regarding third-party products or services does not constitute a license to use such products or services or a warranty or endorsement thereof. Use of such information may require a license from a third party under the patents or other intellectual property of the third party, or a license from TI under the patents or other intellectual property of TI.

Reproduction of significant portions of TI information in TI data books or data sheets is permissible only if reproduction is without alteration and is accompanied by all associated warranties, conditions, limitations, and notices. TI is not responsible or liable for such altered documentation. Information of third parties may be subject to additional restrictions.

Resale of TI components or services with statements different from or beyond the parameters stated by TI for that component or service voids all express and any implied warranties for the associated TI component or service and is an unfair and deceptive business practice. TI is not responsible or liable for any such statements.

Buyer acknowledges and agrees that it is solely responsible for compliance with all legal, regulatory and safety-related requirements concerning its products, and any use of TI components in its applications, notwithstanding any applications-related information or support that may be provided by TI. Buyer represents and agrees that it has all the necessary expertise to create and implement safeguards which anticipate dangerous consequences of failures, monitor failures and their consequences, lessen the likelihood of failures that might cause harm and take appropriate remedial actions. Buyer will fully indemnify TI and its representatives against any damages arising out of the use of any TI components in safety-critical applications.

In some cases, TI components may be promoted specifically to facilitate safety-related applications. With such components, TI's goal is to help enable customers to design and create their own end-product solutions that meet applicable functional safety standards and requirements. Nonetheless, such components are subject to these terms.

No TI components are authorized for use in FDA Class III (or similar life-critical medical equipment) unless authorized officers of the parties have executed a special agreement specifically governing such use.

Only those TI components which TI has specifically designated as military grade or "enhanced plastic" are designed and intended for use in military/aerospace applications or environments. Buyer acknowledges and agrees that any military or aerospace use of TI components which have **not** been so designated is solely at the Buyer's risk, and that Buyer is solely responsible for compliance with all legal and regulatory requirements in connection with such use.

TI has specifically designated certain components as meeting ISO/TS16949 requirements, mainly for automotive use. In any case of use of non-designated products, TI will not be responsible for any failure to meet ISO/TS16949.

### Products

Audio	<a href="http://www.ti.com/audio">www.ti.com/audio</a>
Amplifiers	<a href="http://amplifier.ti.com">amplifier.ti.com</a>
Data Converters	<a href="http://dataconverter.ti.com">dataconverter.ti.com</a>
DLP® Products	<a href="http://www.dlp.com">www.dlp.com</a>
DSP	<a href="http://dsp.ti.com">dsp.ti.com</a>
Clocks and Timers	<a href="http://www.ti.com/clocks">www.ti.com/clocks</a>
Interface	<a href="http://interface.ti.com">interface.ti.com</a>
Logic	<a href="http://logic.ti.com">logic.ti.com</a>
Power Mgmt	<a href="http://power.ti.com">power.ti.com</a>
Microcontrollers	<a href="http://microcontroller.ti.com">microcontroller.ti.com</a>
RFID	<a href="http://www.ti-rfid.com">www.ti-rfid.com</a>
OMAP Applications Processors	<a href="http://www.ti.com/omap">www.ti.com/omap</a>
Wireless Connectivity	<a href="http://www.ti.com/wirelessconnectivity">www.ti.com/wirelessconnectivity</a>

### Applications

Automotive and Transportation	<a href="http://www.ti.com/automotive">www.ti.com/automotive</a>
Communications and Telecom	<a href="http://www.ti.com/communications">www.ti.com/communications</a>
Computers and Peripherals	<a href="http://www.ti.com/computers">www.ti.com/computers</a>
Consumer Electronics	<a href="http://www.ti.com/consumer-apps">www.ti.com/consumer-apps</a>
Energy and Lighting	<a href="http://www.ti.com/energy">www.ti.com/energy</a>
Industrial	<a href="http://www.ti.com/industrial">www.ti.com/industrial</a>
Medical	<a href="http://www.ti.com/medical">www.ti.com/medical</a>
Security	<a href="http://www.ti.com/security">www.ti.com/security</a>
Space, Avionics and Defense	<a href="http://www.ti.com/space-avionics-defense">www.ti.com/space-avionics-defense</a>
Video and Imaging	<a href="http://www.ti.com/video">www.ti.com/video</a>

### TI E2E Community

[e2e.ti.com](http://e2e.ti.com)