



EVERBOUQUET INTERNATIONAL CO., LTD.

WE CATCH THE
BEST TECH. FOREVER

AVAILABLE FROM MIDAS COMPONENTS LTD
TEL +44 1493 602602 www.midascomponents.co.uk

PART NO. : MG1603GC9-SERIES

FOR MESSRS. : _____

CONTENTS

<i>NO.</i>	<i>ITEM</i>	<i>PAGE</i>
1.	COVER	1
2.	RECORD OF REVISION	2
3.	GENERAL SPECIFICATION	3
4.	MECHANICAL DATA	4
5.	ABSOLUTE MAXIMUM RATINGS	5
6.	ELECTRICAL CHARACTERISTICS	6
7.	OPTICAL CHARACTERISTICS	7
8.	OUTLINE DIMENSION	8,9
9.	BLOCK DIAGRAM	10
10.	POWER SUPPLY FOR LCM	11



ACCEPTED BY : _____ PROPOSED BY : _____

RECORD OF REVISION

DATE	PAGE	SUMMARY

3. General specifications

3.1 General specifications

PLEASE REFER TO :

- a. "CUSTOMER ACCEPTANCE STANDARD SPECIFICATIONS (MS-10-10000)"
- b. "CUSTOMER ACCEPTANCE STANDARD SPECIFICATIONS (IC-ST7920)"

3.2 This individual specification is prior to general specifications

3.3 NUMBERING SYSTEM

MG1603G

C	W
---	---

9-

S	Y	M	L	W	U	N
---	---	---	---	---	---	---

(1) (2) (3) (4) (5) (6) (7) (8) (9)

(1).CHARACTER FONTS :

PLEASE REFER TO :

Symbol	Product	Font type
B	IC-ST7920-0B	GB code simplified character set
C	IC-ST7920-0C	GB code,BIG-5 code and Japanese code

(2).LCM TEMPERATURE :

"nil" : NORMAL TEMP

"W" : WIDE TEMP

(3).LCD TYPE :

"S" : STN TYPE

"F" : FSTN TYPE

(4).LCD COLOR :

"Y" : YELLOW-GREEN "B" : BLUE(STN/NEGATIVE)/BLACK(FSTN/NEGATIVE)

"G" : GRAY "W" : WHITE(FSTN/POSITIVE)

(5).LCD POLARIZE TYPE :

"nil" : TRANSFLECTIVE

"M" : TRANSMISSIVE

(6).BACKLIGHT TYPE :

"L" : LED BACKLIGHT

(7).BACKLIGHT COLOR :

LED TYPE :

"nil" : YELLOW-GREEN "A" : AMBER "B" : BLUE

"G" : PURE GREEN "O" : ORANGE "R" : RED

"W" : WHITE

(8). VIEWING DIRECTION :

"nil" : 6 O'CLOCK "3" : 3 O'CLOCK

"U" : 12 O'CLOCK "9" : 9 O'CLOCK

(9).BACKLIGHT TYPE :

"nil" : A(+),K(-)---NORMAL

"N" : A(+),K(-)---CHANGE

4. Mechanical data

- (1) NUMBER OF DOT -----160 W * 32 H DOTS
- (2) MODULE SIZE -----80.0 W * 36.0 H * 10.0 T (Max) mm
- (3) EFFECTIVE AREA -----64.5 W * 16.0 H mm
- (4) ACTIVE AREA -----59.17 W * 11.81 H mm
- (5) DOT SIZE-----0.34 W * 0.34 H mm
- (6) DOT PITCH -----0.37 W * 0.37 H mm

5. Absolute maximum ratings

5.1 Electrical absolute maximum ratings

<i>I T E M</i>	<i>SYMBOL</i>	<i>MIN.</i>	<i>MAX.</i>	<i>UNIT</i>	<i>COMMENT</i>
POWER SUPPLY FOR LOGIC	V _{DD} -V _{SS}	-0.3	5.5	V	-----
POWER SUPPLY FOR LCD	V _O	-0.3	3.5	V	-----
INPUT VOLTAGE	V _I	-0.3	V _{DD} +0.3	V	-----
STATIC ELECTRICITY	-----	-----	100	V	NOTE(1)
POWER SUPPLY FOR LED	NOTE(2)	-----	NOTE(2)	V	-----

NOTE (1): ELECTRO-STATIC DISCHARGE RESISTANCE IS TESTED BY CHARGING A 200pF CAPACITOR AND DISCHARGING IT BY CONTACT WITH A INTERFACE CONNECTOR PIN.

NOTE (2):

<i>SYMBOL</i>	<i>V_{LED} MAX.</i>	<i>LED TYPE</i>
V _{LED}	5.5V	YELLOW-GREEN,AMBER,ORANGE,RED
	5.0V	BLUE,PURE GREEN,WHITE

5.2 Environmental absolute maximum ratings

<i>I T E M</i>	<i>CONDITION</i>	<i>OPERATING</i>		<i>STORAGE</i>		<i>COMMENT</i>
		<i>MIN.</i>	<i>MAX.</i>	<i>MIN.</i>	<i>MAX.</i>	
AMBIENT TEMPERATURE	NORMAL	0	50	-20	70	-----
	WIDE	-20	70			
HUMIDITY	-----	NOTE (3)		NOTE (3)		NO CONDENSATION
VIBRATION NOTE (4)	-----	-----	0.5G	-----	2G	10~300Hz XYZ DIRECTIONS 1 Hr EACH
SHOCK NOTE (4)	-----	-----	3G	-----	50G	10 msec XYZ DIRECTIONS 1 TIME EACH
CORROSIVE GAS	-----	NOT ACCEPTABLE		NOT ACCEPTABLE		-----

NOTE (3):Ta 50 : 90% RH MAX.

Ta > 50 : ABSOLUTE HUMIDITY MUST BE LOWER THAN THE HUMIDITY OF 90% RH AT 50 . (80% RH AT 60)

NOTE (4):1G = 9.8 m/s²

6. Electrical characteristics

Ta = 25

<i>I T E M</i>	<i>SYMBOL</i>	<i>CONDITION</i>	<i>MIN.</i>	<i>TYP.</i>	<i>MAX.</i>	<i>UNIT</i>	
POWER SUPPLY VOLTAGE FOR CIRCUIT	V _{DD} - V _{SS}	-----	2.7	-----	5.5	V	
INPUT VOLTAGE	V _{IH}	-----	0.7 V _{DD}	-----	V _{DD}	V	
	V _{IL}	-----	-0.3	-----	0.6	V	
OUTPUT VOLTAGE	V _{OH}	I _{OH} = -0.1 mA	0.8V _{DD}	-----	V _{DD}	V	
	V _{OL}	I _{OL} = 0.1 mA	-----	-----	0.1	V	
POWER SUPPLY CURRENT	I _{DD}	V _{DD} - V _{SS}	-----	0.5	1.0	mA	
RECOMMENDED LCD DRIVING VOLTAGE, NOTE(1)	V _O -V _{SS}	STN/ FSTN DUTY =1/32 =10° NOTE(2)	Ta= -20°C	-----	-----	-----	V
			Ta= 0°C	-----	-----	-----	V
			Ta= 25°C	-----	2.9	-----	V
			Ta= 50°C	-----	-----	-----	V
			Ta= 70°C	-----	-----	-----	V
POWER SUPPLY CURRENT FOR NOTE(3)	I _{LED}	V _{LED} =NOTE(3)	-----	NOTE(3)	NOTE(3)	mA	

NOTE (1): RECOMMENDED LCD DRIVING VOLTAGE MAY FLUCTUATE ABOUT ±0.5V BY EACH MODULE.

- (2): = 0° : VIEWING DIRECTION AT 6 O'CLOCK
 = 180° : VIEWING DIRECTION AT 12 O'CLOCK

(3): LED CURRENT OF DIFFERENT LED TYPE

<i>LED B.L TYPE</i>	<i>V_{LED}</i>	<i>I_{LED}</i>				<i>LED COLOR</i>
		<i>MIN.</i>	<i>TYP.</i>	<i>MAX.</i>	<i>UNIT.</i>	
A	4.8V	-----	30	40	mA	YELLOW-GREEN, AMBER, ORANGE, RED
B	4.0V	-----	30	40	mA	BLUE, WHITE, PURE GREEN

7. Optical characteristics

STN TYPE LCD

Ta = 25

<i>I T E M</i>	<i>SYMBOL</i>	<i>CONDITION</i>	<i>MIN.</i>	<i>TYP.</i>	<i>MAX.</i>	<i>UNIT</i>	<i>NOTE</i>
VIEWING ANGLE	2- 1	K = 2.0 NOTE(1)	30	40	----	deg.	NOTE(2)
CONTRAST RATIO	K	= 10° NOTE(1)	3.0	4.0	----	----	NOTE(2)
RESPONSE TIME	tr (rise)	= 10° NOTE(1)	----	200	350	ms	NOTE(2)
	tf (fall)	= 10° NOTE(1)	----	300	400	ms	NOTE(2)

FSTN /STN BLUE TYPE LCD

Ta = 25

<i>I T E M</i>	<i>SYMBOL</i>	<i>CONDITION</i>	<i>MIN.</i>	<i>TYP.</i>	<i>MAX.</i>	<i>UNIT</i>	<i>NOTE</i>
VIEWING ANGLE	2- 1	K = 2.0 NOTE(1)	30	40	----	deg.	NOTE(2)
CONTRAST RATIO	K	= 10° NOTE(1)	4.0	5.0	----	----	NOTE(2)
RESPONSE TIME	tr (rise)	= 10° NOTE(1)	----	200	350	ms	NOTE(2)
	tf (fall)	= 10° NOTE(1)	----	300	400	ms	NOTE(2)

Brightness for LCM backlight

<i>SYMBOL</i>	<i>CONDITION</i>	<i>MIN.</i>	<i>TYP.</i>	<i>MAX.</i>	<i>UNIT</i>	<i>LED TYPE</i>	<i>NOTE</i>
B	= 0°	4.0	----	----	cd/m ²	YELLOW-GREEN, RED, AMBER, ORANGE	NOTE(2)
	= 0°	6.0	----	----		BLUE, PURE GREEN, WHITE	NOTE(3)

NOTE (1): = 0° WHEN VIEWING DIRECTION AT 6 O'CLOCK

= 180° WHEN VIEWING DIRECTION AT 12 O'CLOCK

(2): SEE CUSTOMER ACCEPTANCE STANDARD SPECIFICATION FOR DEFINITION OF OPTICAL CHARACTERISTICS.

(3): UNDER NORMAL TEMPERATURE AND HUMIDITY IN A DARK ROOM.

8. Outline dimension

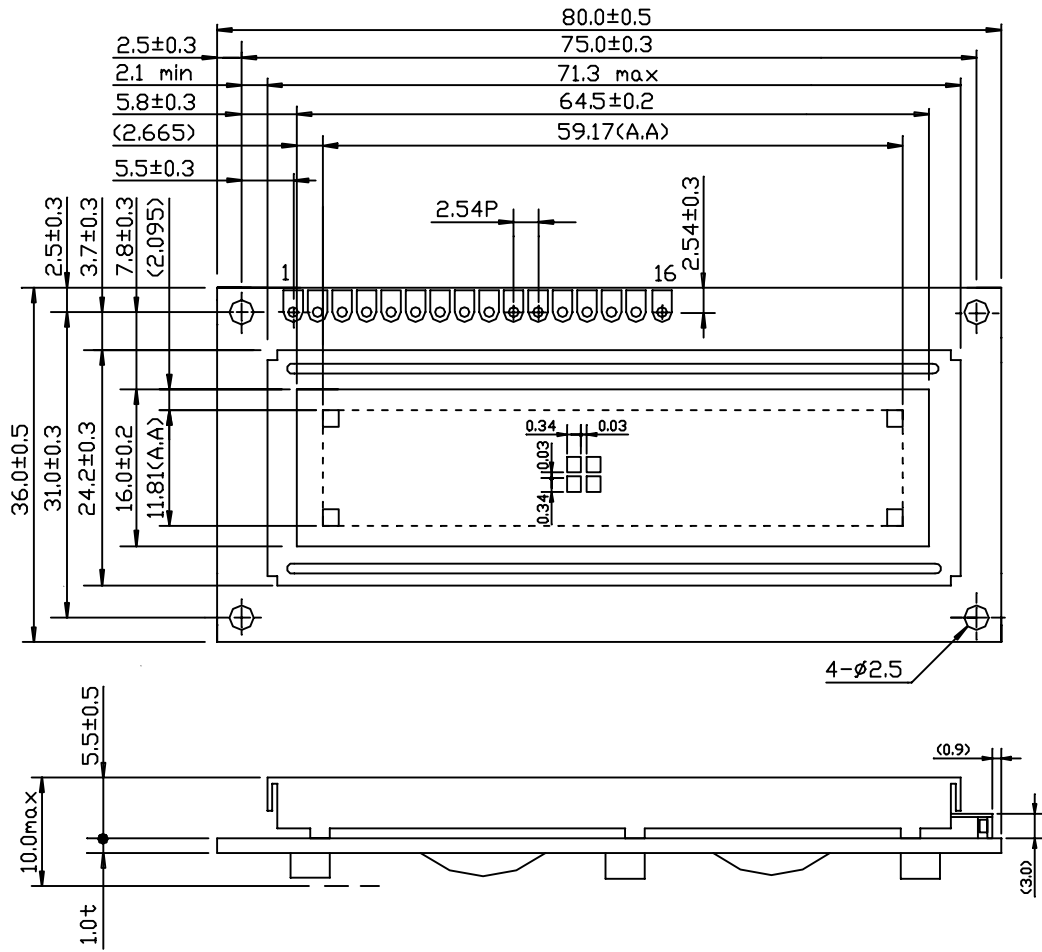

NOTE :
 1.UNIT : mm
 2.SCALE : NTS

8.1 Interface pin connection

<i>PIN NO.</i>	<i>SYMBOL</i>	<i>FUNCTION</i>
1	V _{SS}	POWER SUPPLY (GND)
2	V _{DD}	POWER SUPPLY (+5V)
3	V _o	POWER SUPPLY FOR LCD
4	RS	RS = "H" DB0~DB7 FOR DISPLAY DATA RS = "L" DB0~DB7 FOR CONTROL DATA
5	R/ \bar{W}	H: DATA READ (LCD MODULE MPU) L: DATA WRITE (LCD MODULE MPU)
6	E	ENABLE SIGNAL
7	DB0	DATA INPUT/OUTPUT (LSB)
8	DB1	DATA INPUT/OUTPUT
9	DB2	DATA INPUT/OUTPUT
10	DB3	DATA INPUT/OUTPUT
11	DB4	DATA INPUT/OUTPUT
12	DB5	DATA INPUT/OUTPUT
13	DB6	DATA INPUT/OUTPUT
14	DB7	DATA INPUT/OUTPUT (MSB)
15	A(+)	POWER SUPPLY FOR LED (+)
16	K(-)	POWER SUPPLY FOR LED (-)

9. Block diagram

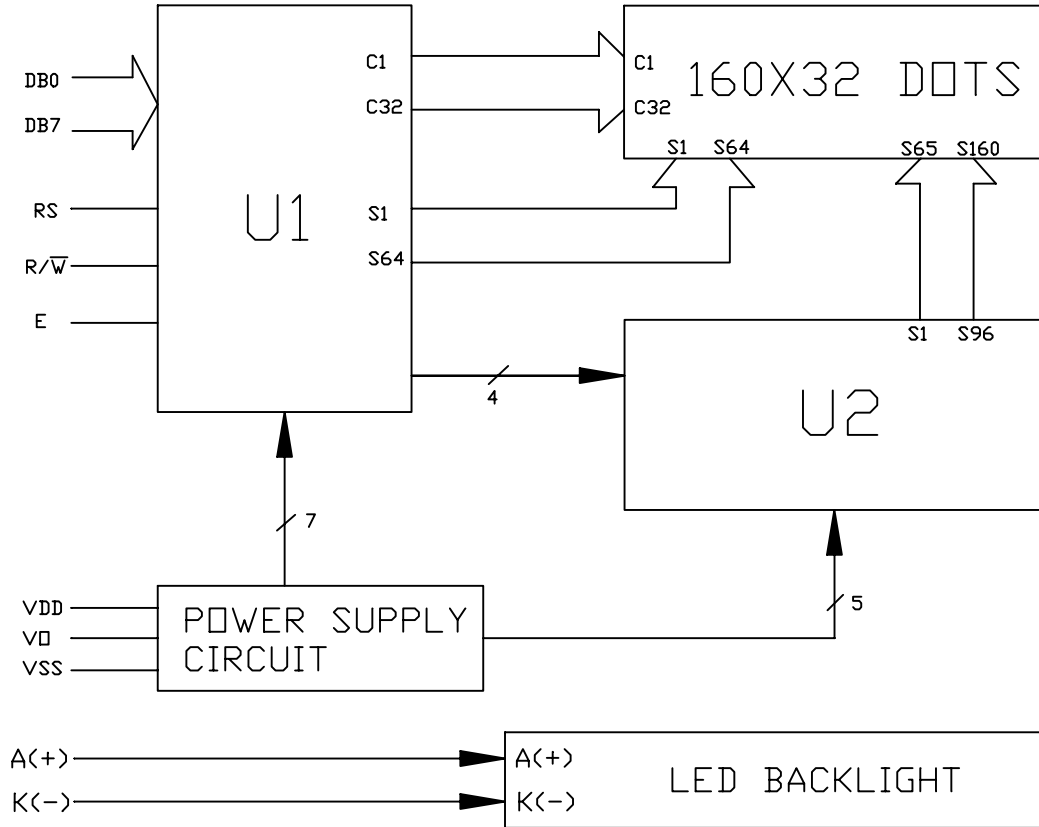

10. Power supply for LCM

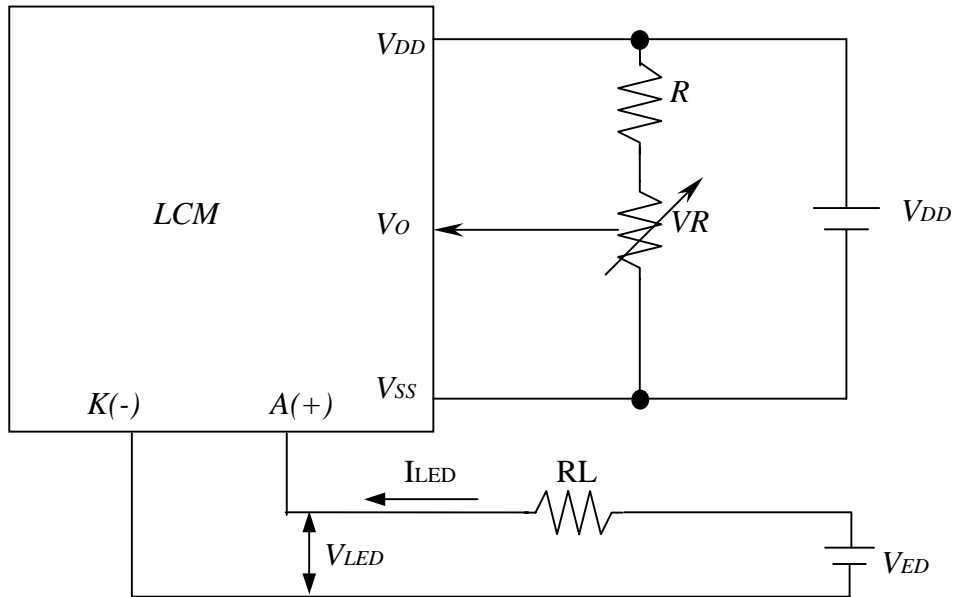

$V_o - V_{SS}$: LCD DRIVING VOLTAGE

V_R : $10K\Omega \sim 20K\Omega$

<i>ITEM</i>	<i>LED B.L TYPE</i>	<i>CONDITION</i>
Limit resistor of LED (R_L)	A	$R_L = ((V_{ED} - 4.8V) / I_{LED})$, $I_{LED} = 40mA$
	B	$R_L = ((V_{ED} - 4.0V) / I_{LED})$, $I_{LED} = 40mA$