

IEC Appliance Inlet C14 with Line Switch 2-pole



**Description**

- Panel Mount:  
Screw-on version from front or rear side, snap-in version from front side
- 2 Functions:  
Appliance Inlet Protection class I, Line Switch 2-pole
- Quick connect terminals 4.8 x 0.8 mm

**Approvals**

- VDE Certificate Number: 40021945
- UL File Number: E96454
- CSA File Number: 38456

**Characteristics**

- All single elements are already wired  
Unwired versions available on request
- Line switch non-illuminated or illuminated

**Other versions on request**

- Unwired versions
- Line switch with other rocker marking
- For protection class II

**References**

Alternative: version with line filter [KFB2](#)  
We recommend for new applications the new type [DC11](#)

**Weblinks**

[pdf-datasheet](#), [html-datasheet](#), [General Product Information](#), [Approvals](#), [CE declaration of conformity](#), [RoHS](#), [CHINA-RoHS](#), [REACH](#), [Mating Connectors](#), [e-Shop](#), [SCHURTER-Stock-Check](#), [Distributor-Stock-Check](#), [CAD-Drawings](#), [Accessories](#), [Detailed request for product](#)

**Technical Data**

Ratings IEC	10A / 250VAC; 50Hz	Appliance Inlet	C14 acc. to IEC 60320, UL 498, CSA C22.2 no. 42 (for cold conditions) pin-temperature 70 °C, 10A, Protection Class I
Ratings UL/CSA	15A / 250VAC; 60Hz	Line Switch	Rocker switch 2-pole, non-illuminated or illuminated, acc. to IEC 61058-1 <a href="#">Technical Details</a>
Dielectric Strength	> 2.5kVAC between L-N > 3kVAC between L/N-PE (1 min/50Hz)		
Allowable Operation Temp.	-25 °C to 70 °C		
Degree of Protection	from front side IP 40 acc. to IEC 60529		
Protection Class	Suitable for appliances with protection class I acc. to IEC 61140		
Terminal	Quick connect terminals 4.8 x 0.8 mm		
Panel Thickness s	Screw: max 6 mm Mounting screw torque max 0.5Nm Snap-in: 1.5/2/2.5 mm		
Material: Housing	Thermoplastic, black, UL 94V-0		

Dimensions

Screw-on mounting

Snap-in mounting

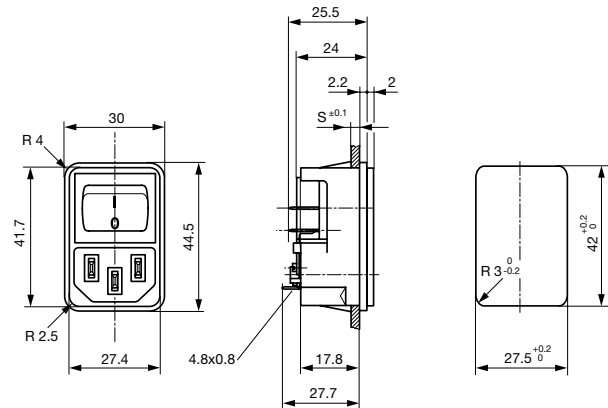
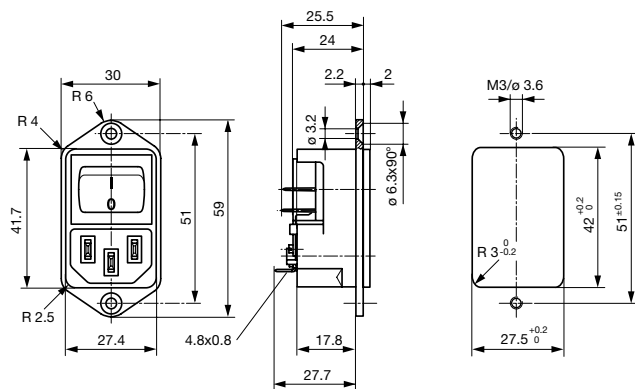

Diagrams

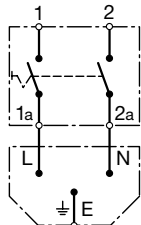

non-illuminated

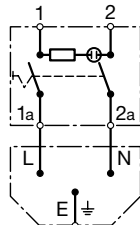

illuminated

All Variants

Panel mounting	Panel Thickness s [mm]	Illumination	Rated voltage 125/250 [V]	Color	Order Number
Snap-in	1.5	●	250	red	4302.2102
Snap-in	1.5	●	250	green	4302.2142
Snap-in	2	●	250	red	4302.2103
Snap-in	2	●	250	green	4302.2143
Snap-in	2.5	●	250	red	4302.2104
Snap-in	2.5	●	250	green	4302.2144
Snap-in	1.5	-	-	-	4302.2002
Snap-in	2	-	-	-	4302.2003
Snap-in	2.5	-	-	-	4302.2004
Screw	-	●	250	red	4302.2101
Screw	-	●	250	green	4302.2141
Screw	-	-	-	-	4302.2001

Most Popular.

Availability for all products can be searched real-time: <http://www.schurter.com/en/Stock-Check/Stock-Check-SCHURTER>

Packaging unit

50 Pcs

Accessories

Description

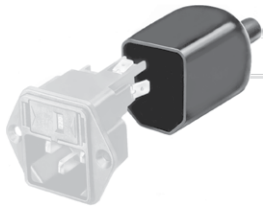

Assorted Covers  
Rear Cover

0859.0075



Cord retaining kits  
Cord retaining strain relief

Flat head, A

4700.0001

Mating Outlets/Connectors

Category / Description

Appliance Outlet Overview complete



IEC Appliance Outlet F, Screw-on Mounting, Front Side, Solder Terminal	4787
IEC Appliance Outlet F, Snap-in Mounting, Front Side, Solder or Quick-connect Terminal	4788
IEC Appliance Outlet F or H, Screw-on Mounting, Front Side, Solder, PCB or Quick-connect Terminal	5091

Appliance Outlet further types to KEB2

Connector Overview complete



4782 Mounting: Power Cord, 3 x 1 mm <sup>2</sup> / 3 x 18 AWG, Cable, Connector: IEC C13	4782
4022 Mounting: Power Supply Cord, 3 x 1.5 mm <sup>2</sup> , Screw clamps, Connector: IEC C13	4022
4785 Mounting: Power Cord, 3 x 1 mm <sup>2</sup> / 3 x 18 AWG, Cable, Connector: IEC C13	4785
4300-06 Mounting: Power Cord, 3 x 1 mm <sup>2</sup> / 3 x 18 AWG, Cable, Connector: IEC C13	4300-06
4012 Mounting: Power Supply Cord, 3 x 1.5 mm <sup>2</sup> , Screw clamps, Connector: IEC C13	4012

Connector further types to KEB2

...