

MSP430 Hardware Tools

User's Guide



Literature Number: SLAU278X
May 2009–Revised February 2016

Preface	9
1 Get Started Now!	12
1.1 Kit Contents, MSP-TS430xx	13
1.2 Kit Contents, MSP-FET430xx	15
1.3 Kit Contents, MSP-FET	15
1.4 Kit Contents, MSP-FET430UIF	15
1.5 Kit Contents, MSP-FET430PIF	15
1.6 Kit Contents, eZ430-F2013	15
1.7 Kit Contents, eZ430-T2012	15
1.8 Kit Contents, eZ430-RF2500	16
1.9 Kit Contents, eZ430-RF2500T	16
1.10 Kit Contents, eZ430-RF2500-SEH	16
1.11 Kit Contents, eZ430-Chronos-xxx	16
1.12 Kit Contents, FET430F6137RF900	17
1.13 Kit Contents, EM430Fx1x7RF900	17
1.14 Hardware Installation, MSP-FET	18
1.15 Hardware Installation, MSP-FET430UIF	18
1.16 Hardware Installation, MSP-FET430PIF	19
1.17 Hardware Installation, MSP-TS430xxx, MSP-FET430Uxx, FET430F6137RF900, EM430Fx1x7RF900	19
1.18 Hardware Installation, eZ430-XXXX, MSP-EXP430G2, MSP-EXP430FR5739, MSPEXP430F5529	19
1.19 Important MSP430 Documents on the Web	19
2 Design Considerations for In-Circuit Programming	20
2.1 Signal Connections for In-System Programming and Debugging	21
2.2 External Power	25
2.3 Bootloader (BSL)	25
A Frequently Asked Questions and Known Issues	26
A.1 Hardware FAQs	27
A.2 Known Issues	29
B Hardware	30
B.1 MSP-TS430D8	32
B.2 MSP-TS430PW14	35
B.3 MSP-TS430L092	38
B.4 MSP-TS430L092 Active Cable	41
B.5 MSP-TS430PW20	44
B.6 MSP-TS430PW24	48
B.7 MSP-TS430RGE24A	51
B.8 MSP-TS430DW28	54
B.9 MSP-TS430PW28	57
B.10 MSP-TS430PW28A	60
B.11 MSP-TS430RHB32A	63
B.12 MSP-TS430DA38	66
B.13 MSP-TS430QFN23x0	69
B.14 MSP-TS430RSB40	72
B.15 MSP-TS430RHA40A	75

B.16	MSP-TS430DL48.....	78
B.17	MSP-TS430RGZ48B.....	81
B.18	MSP-TS430RGZ48C	84
B.19	MSP-TS430PM64	87
B.20	MSP-TS430PM64A	90
B.21	MSP-TS430PM64D	93
B.22	MSP-TS430PM64F	96
B.23	MSP-TS430RGC64B	99
B.24	MSP-TS430RGC64C.....	102
B.25	MSP-TS430RGC64USB	106
B.26	MSP-TS430PN80	110
B.27	MSP-TS430PN80A	113
B.28	MSP-TS430PN80USB	116
B.29	MSP-TS430PZ100.....	120
B.30	MSP-TS430PZ100A	123
B.31	MSP-TS430PZ100B.....	126
B.32	MSP-TS430PZ100C.....	129
B.33	MSP-TS430PZ100D.....	132
B.34	MSP-TS430PZ5x100.....	135
B.35	MSP-TS430PZ100USB	138
B.36	MSP-TS430PZ100AUSB	142
B.37	MSP-TS430PEU128.....	146
B.38	EM430F5137RF900	149
B.39	EM430F6137RF900	153
B.40	EM430F6147RF900	157
B.41	MSP-FET	161
	B.41.1 Features	161
	B.41.2 Release Notes	161
	B.41.3 Schematics	164
	B.41.4 Layout.....	169
	B.41.5 LED Signals	169
	B.41.6 JTAG Target Connector	170
	B.41.7 Specifications	172
	B.41.8 MSP-FET Revision History.....	172
B.42	MSP-FET430UIF.....	173
	B.42.1 MSP-FET430UIF Revision History	178
B.43	MSP-FET430PIF.....	179
C	Hardware Installation Guide	181
	C.1 Hardware Installation	182
	Revision History	187

List of Figures

2-1.	Signal Connections for 4-Wire JTAG Communication.....	22
2-2.	Signal Connections for 2-Wire JTAG Communication (Spy-Bi-Wire) Used by MSP430F2xx, MSP430G2xx, and MSP430F4xx Devices.....	23
2-3.	Signal Connections for 2-Wire JTAG Communication (Spy-Bi-Wire) Used by All MSP430 SBW-Capable Devices That are Not Part of F2xx, G2xx, F4xx Families.....	24
B-1.	MSP-TS430D8 Target Socket Module, Schematic	32
B-2.	MSP-TS430D8 Target Socket Module, PCB	33
B-3.	MSP-TS430PW14 Target Socket Module, Schematic	35
B-4.	MSP-TS430PW14 Target Socket Module, PCB	36
B-5.	MSP-TS430L092 Target Socket Module, Schematic.....	38
B-6.	MSP-TS430L092 Target Socket Module, PCB.....	39
B-7.	MSP-TS430L092 Active Cable Target Socket Module, Schematic.....	41
B-8.	MSP-TS430L092 Active Cable Target Socket Module, PCB.....	42
B-9.	UART BSL Signal Select	44
B-10.	MSP-TS430PW20 Target Socket Module, Schematic	45
B-11.	MSP-TS430PW20 Target Socket Module, PCB	46
B-12.	MSP-TS430PW24 Target Socket Module, Schematic	48
B-13.	MSP-TS430PW24 Target Socket Module, PCB	49
B-14.	MSP-TS430RGE24A Target Socket Module, Schematic.....	51
B-15.	MSP-TS430RGE24A Target Socket Module, PCB	52
B-16.	MSP-TS430DW28 Target Socket Module, Schematic	54
B-17.	MSP-TS430DW28 Target Socket Module, PCB	55
B-18.	MSP-TS430PW28 Target Socket Module, Schematic	57
B-19.	MSP-TS430PW28 Target Socket Module, PCB	58
B-20.	MSP-TS430PW28A Target Socket Module, Schematic	60
B-21.	MSP-TS430PW28A Target Socket Module, PCB (Red)	61
B-22.	MSP-TS430RHB32A Target Socket Module, Schematic	63
B-23.	MSP-TS430RHB32A Target Socket Module, PCB	64
B-24.	MSP-TS430DA38 Target Socket Module, Schematic.....	66
B-25.	MSP-TS430DA38 Target Socket Module, PCB.....	67
B-26.	MSP-TS430QFN23x0 Target Socket Module, Schematic	69
B-27.	MSP-TS430QFN23x0 Target Socket Module, PCB	70
B-28.	MSP-TS430RSB40 Target Socket Module, Schematic	72
B-29.	MSP-TS430RSB40 Target Socket Module, PCB	73
B-30.	MSP-TS430RHA40A Target Socket Module, Schematic	75
B-31.	MSP-TS430RHA40A Target Socket Module, PCB	76
B-32.	MSP-TS430DL48 Target Socket Module, Schematic	78
B-33.	MSP-TS430DL48 Target Socket Module, PCB	79
B-34.	MSP-TS430RGZ48B Target Socket Module, Schematic	81
B-35.	MSP-TS430RGZ48B Target Socket Module, PCB	82
B-36.	MSP-TS430RGZ48C Target Socket Module, Schematic	84
B-37.	MSP-TS430RGZ48C Target Socket Module, PCB.....	85
B-38.	MSP-TS430PM64 Target Socket Module, Schematic.....	87
B-39.	MSP-TS430PM64 Target Socket Module, PCB.....	88
B-40.	MSP-TS430PM64A Target Socket Module, Schematic.....	90
B-41.	MSP-TS430PM64A Target Socket Module, PCB.....	91
B-42.	MSP-TS430PM64D Target Socket Module, Schematic.....	93
B-43.	MSP-TS430PM64D Target Socket Module, PCB.....	94

B-44.	MSP-TS430PM64F Target Socket Module, Schematic	96
B-45.	MSP-TS430PM64F Target Socket Module, PCB	97
B-46.	MSP-TS430RGC64B Target Socket Module, Schematic	99
B-47.	MSP-TS430RGC64B Target Socket Module, PCB	100
B-48.	MSP-TS430RGC64C Target Socket Module, Schematic	103
B-49.	MSP-TS430RGC64C Target Socket Module, PCB	104
B-50.	MSP-TS430RGC64USB Target Socket Module, Schematic.....	106
B-51.	MSP-TS430RGC64USB Target Socket Module, PCB.....	107
B-52.	MSP-TS430PN80 Target Socket Module, Schematic	110
B-53.	MSP-TS430PN80 Target Socket Module, PCB	111
B-54.	MSP-TS430PN80A Target Socket Module, Schematic.....	113
B-55.	MSP-TS430PN80A Target Socket Module, PCB.....	114
B-56.	MSP-TS430PN80USB Target Socket Module, Schematic.....	116
B-57.	MSP-TS430PN80USB Target Socket Module, PCB.....	117
B-58.	MSP-TS430PZ100 Target Socket Module, Schematic	120
B-59.	MSP-TS430PZ100 Target Socket Module, PCB	121
B-60.	MSP-TS430PZ100A Target Socket Module, Schematic	123
B-61.	MSP-TS430PZ100A Target Socket Module, PCB	124
B-62.	MSP-TS430PZ100B Target Socket Module, Schematic	126
B-63.	MSP-TS430PZ100B Target Socket Module, PCB	127
B-64.	MSP-TS430PZ100C Target Socket Module, Schematic	129
B-65.	MSP-TS430PZ100C Target Socket Module, PCB	130
B-66.	MSP-TS430PZ100D Target Socket Module, Schematic	132
B-67.	MSP-TS430PZ100D Target Socket Module, PCB	133
B-68.	MSP-TS430PZ5x100 Target Socket Module, Schematic	135
B-69.	MSP-TS430PZ5x100 Target Socket Module, PCB	136
B-70.	MSP-TS430PZ100USB Target Socket Module, Schematic.....	138
B-71.	MSP-TS430PZ100USB Target Socket Module, PCB.....	139
B-72.	MSP-TS430PZ100AUSB Target Socket Module, Schematic.....	142
B-73.	MSP-TS430PZ100AUSB Target Socket Module, PCB.....	143
B-74.	MSP-TS430PEU128 Target Socket Module, Schematic	146
B-75.	MSP-TS430PEU128 Target Socket Module, PCB	147
B-76.	EM430F5137RF900 Target Board, Schematic	149
B-77.	EM430F5137RF900 Target board, PCB.....	150
B-78.	EM430F6137RF900 Target Board, Schematic	153
B-79.	EM430F6137RF900 Target Board, PCB	154
B-80.	EM430F6147RF900 Target Board, Schematic	157
B-81.	EM430F6147RF900 Target Board, PCB	158
B-82.	MSP-FET Top View	162
B-83.	MSP-FET Bottom View	162
B-84.	MSP-FET USB Debugger, Schematic (1 of 5).....	164
B-85.	MSP-FET USB Debugger, Schematic (2 of 5).....	165
B-86.	MSP-FET USB Debugger, Schematic (3 of 5).....	166
B-87.	MSP-FET USB Debugger, Schematic (4 of 5).....	167
B-88.	MSP-FET USB Debugger, Schematic (5 of 5).....	168
B-89.	MSP-FET USB Debugger, PCB (Top)	169
B-90.	MSP-FET USB Debugger, PCB (Bottom)	169
B-91.	JTAG Connector Pinout.....	170
B-92.	Pin States After Power-Up.....	171

B-93.	MSP-FET430UIF USB Interface, Schematic (1 of 4)	173
B-94.	MSP-FET430UIF USB Interface, Schematic (2 of 4)	174
B-95.	MSP-FET430UIF USB Interface, Schematic (3 of 4)	175
B-96.	MSP-FET430UIF USB Interface, Schematic (4 of 4)	176
B-97.	MSP-FET430UIF USB Interface, PCB	177
B-98.	MSP-FET430PIF FET Interface Module, Schematic.....	179
B-99.	MSP-FET430PIF FET Interface Module, PCB.....	180
C-1.	Windows XP Hardware Wizard	182
C-2.	Windows XP Driver Location Selection Folder.....	183
C-3.	Device Manager Using USB Debug Interface using VID/PID 0x2047/0x0010	184
C-4.	Device Manager Using USB Debug Interface with VID/PID 0x0451/0xF430	185
C-5.	Device Manager Using USB Debug Interface With VID/PID 0x0451/0xF432	186

List of Tables

1-1.	Individual Kit Contents, MSP-TS430xx	13
B-1.	MSP-TS430D8 Bill of Materials	34
B-2.	MSP-TS430PW14 Bill of Materials.....	37
B-3.	MSP-TS430L092 Bill of Materials	40
B-4.	MSP-TS430L092 JP1 Settings	42
B-5.	MSP-TS430L092 Active Cable Bill of Materials	43
B-6.	MSP-TS430PW20 Bill of Materials.....	47
B-7.	MSP-TS430PW24 Bill of Materials.....	50
B-8.	MSP-TS430RGE24A Bill of Materials (BOM)	53
B-9.	MSP-TS430DW28 Bill of Materials	56
B-10.	MSP-TS430PW28 Bill of Materials	59
B-11.	MSP-TS430PW28A Bill of Materials.....	62
B-12.	MSP-TS430RHB32A Bill of Materials	65
B-13.	MSP-TS430DA38 Bill of Materials	68
B-14.	MSP-TS430QFN23x0 Bill of Materials	71
B-15.	MSP-TS430RSB40 Bill of Materials	74
B-16.	MSP-TS430RHA40A Bill of Materials	77
B-17.	MSP-TS430DL48 Bill of Materials	80
B-18.	MSP-TS430RGZ48B Bill of Materials	83
B-19.	MSP-TS430RGZ48C Bill of Materials	86
B-20.	MSP-TS430PM64 Bill of Materials.....	89
B-21.	MSP-TS430PM64A Bill of Materials	92
B-22.	MSP-TS430PM64D Bill of Materials.....	95
B-23.	MSP-TS430PM64F Bill of Materials (BOM)	98
B-24.	MSP-TS430RGC64B Bill of Materials.....	101
B-25.	MSP-TS430RGC64C Bill of Materials	105
B-26.	MSP-TS430RGC64USB Bill of Materials.....	108
B-27.	MSP-TS430PN80 Bill of Materials.....	112
B-28.	MSP-TS430PN80A Bill of Materials.....	115
B-29.	MSP-TS430PN80USB Bill of Materials	118
B-30.	MSP-TS430PZ100 Bill of Materials	122
B-31.	MSP-TS430PZ100A Bill of Materials.....	125
B-32.	MSP-TS430PZ100B Bill of Materials.....	128
B-33.	MSP-TS430PZ100C Bill of Materials	131
B-34.	MSP-TS430PZ100D Bill of Materials	134
B-35.	MSP-TS430PZ5x100 Bill of Materials.....	137
B-36.	MSP-TS430PZ100USB Bill of Materials	140
B-37.	MSP-TS430PZ100AUSB Bill of Materials	144
B-38.	MSP-TS430PEU128 Bill of Materials	148
B-39.	EM430F5137RF900 Bill of Materials.....	151
B-40.	EM430F6137RF900 Bill of Materials.....	155
B-41.	EM430F6147RF900 Bill of Materials.....	159
B-42.	UART Backchannel Implementation	161
B-43.	UART Backchannel Activation Commands.....	162
B-44.	MSP Target BSL Activation Commands.....	163
B-45.	MSP-FET LED Signals.....	169
B-46.	JTAG Connector Pin State by Operating Mode	170

B-47. Specifications.....	172
B-48. MSP-FET Revision History	172
C-1. USB VIDs and PIDs Used in MSP430 Tools.....	182

Read This First

About This Manual

This manual describes the hardware of the TI MSP-FET430 Flash Emulation Tool (FET). The FET is the program development tool for the MSP430™ ultra-low-power microcontroller. Both available interface types, the parallel port interface and the USB interface, are described.

How to Use This Manual

Read and follow the instructions in [Chapter 1](#). This section lists the contents of the FET, provides instructions on installing the hardware and according software drivers. After you see how quick and easy it is to use the development tools, TI recommends that you read all of this manual.

This manual describes the setup and operation of the FET but does not fully describe the MSP430™ microcontrollers or the development software systems. For details of these items, see the appropriate TI documents listed in [Section 1.19](#).

This manual applies to the following tools (and devices):

- MSP-FET430PIF (debug interface with parallel port connection, for all MSP430 flash-based devices)
- MSP-FET430UIF (debug interface with USB connection, for all MSP430 flash-based devices)
- MSP-FET (successor to MSP-FET430UIF, debug interface with USB connection, for all MSP430 devices)
- eZ430-F2013 (USB stick form factor interface with attached MSP430F2013 target, for all MSP430F20xx, MSP430G2x01, MSP430G2x11, MSP430G2x21, and MSP430G2x31 devices)
- eZ430-T2012 (three MSP430F2012 based target boards)
- eZ430-RF2500 (USB stick form factor interface with attached MSP430F2274 and CC2500 target, for all MSP430F20xx, MSP430F21x2, MSP430F22xx, MSP430G2x01, MSP430G2x11, MSP430G2x21, and MSP430G2x31 devices)
- eZ430-RF2500T (one MSP430F2274 and CC2500 target board including battery pack)
- eZ430-RF2500-SEH (USB stick form factor interface with attached MSP430F2274 and CC2500 target and solar energy harvesting module)
- eZ430-Chronos-xxx (USB stick form factor interface with CC430F6137 based development system contained in a watch. Includes <1 GHz RF USB access point)

Stand-alone target-socket modules (without debug interface) named as MSP-TS430TSxx.

Tools named as MSP-FET430Uxx contain the USB debug interface (MSP-FET430UIF) and the respective target socket module MSP-TS430TSxx, where 'xx' is the same for both names. The following tools contain also the USB debug interface (MSP-FET430UIF):

- FET430F5137RF900 (for CC430F513x devices in 48-pin RGZ packages) (green PCB)
- FET430F6137RF900 (for CC430F612x and CC430F613x devices in 64-pin RGC packages) (green PCB)

These tools contain the most up-to-date materials available at the time of packaging. For the latest materials (data sheets, user's guides, software, application information, and so on), visit the TI MSP430 website at www.ti.com/msp430 or contact your local TI sales office.

Information About Cautions and Warnings

This document may contain cautions and warnings.

CAUTION

This is an example of a caution statement.

A caution statement describes a situation that could potentially damage your software or equipment.

WARNING

This is an example of a warning statement.

A warning statement describes a situation that could potentially cause harm to you.

The information in a caution or a warning is provided for your protection. Read each caution and warning carefully.

Related Documentation From Texas Instruments

MSP430 development tools documentation:

MSP Debuggers User's Guide ([SLAU647](#))

Code Composer Studio for MSP430 User's Guide ([SLAU157](#))

Code Composer Studio v5.x Core Edition ([CCS Mediawiki](#))

IAR Embedded Workbench for MSP430(tm) User's Guide ([SLAU138](#))

IAR Embedded Workbench KickStart installer ([SLAC050](#))

eZ430-F2013 Development Tool User's Guide ([SLAU176](#))

eZ430-RF2480 Demonstration Kit User's Guide ([SWRU151](#))

eZ430-RF2500 Development Tool User's Guide ([SLAU227](#))

eZ430-RF2500-SEH Development Tool User's Guide ([SLAU273](#))

eZ430-Chronos Development Tool User's Guide ([SLAU292](#))

Spectrum Analyzer (MSP-SA430-SUB1GHZ) User's Guide ([SLAU371](#))

MSP-EXP430F5529 Experimenter Board User's Guide ([SLAU330](#))

MSP-EXP430F5438 Experimenter Board User's Guide ([SLAU263](#))

MSP-EXP430G2 LaunchPad Experimenter Board User's Guide ([SLAU318](#))

MSP Gang Programmer (MSP-GANG) User's Guide ([SLAU358](#))

MSP430 Gang Programmer (MSP-GANG430) User's Guide ([SLAU101](#))

MSP430 device user's guides:

MSP430x1xx Family User's Guide ([SLAU049](#))

MSP430x2xx Family User's Guide ([SLAU144](#))

MSP430x3xx Family User's Guide ([SLAU012](#))

MSP430x4xx Family User's Guide ([SLAU056](#))

MSP430x5xx and MSP430x6xx Family User's Guide ([SLAU208](#))

CC430 Family User's Guide ([SLAU259](#))

MSP430FR57xx Family User's Guide ([SLAU272](#))

MSP430FR58xx and MSP430FR59xx Family User's Guide ([SLAU367](#))

If You Need Assistance

Support for the MSP430 devices and the FET development tools is provided by the Texas Instruments Product Information Center (PIC). Contact information for the PIC can be found on the TI website at www.ti.com/support. The Texas Instruments [E2E™ Community support forums](#) for the [MSP430](#) provide open interaction with peer engineers, TI engineers, and other experts. Additional device-specific information can be found on the [MSP430 website](#).

Get Started Now!

This chapter lists the contents of the FET and provides instruction on installing the hardware.

Topic	Page
1.1 Kit Contents, MSP-TS430xx	13
1.2 Kit Contents, MSP-FET430xx	15
1.3 Kit Contents, MSP-FET	15
1.4 Kit Contents, MSP-FET430UIF	15
1.5 Kit Contents, MSP-FET430PIF	15
1.6 Kit Contents, eZ430-F2013	15
1.7 Kit Contents, eZ430-T2012	15
1.8 Kit Contents, eZ430-RF2500	16
1.9 Kit Contents, eZ430-RF2500T	16
1.10 Kit Contents, eZ430-RF2500-SEH	16
1.11 Kit Contents, eZ430-Chronos-xxx	16
1.12 Kit Contents, FET430F6137RF900	17
1.13 Kit Contents, EM430Fx1x7RF900	17
1.14 Hardware Installation, MSP-FET	18
1.15 Hardware Installation, MSP-FET430UIF	18
1.16 Hardware Installation, MSP-FET430PIF	19
1.17 Hardware Installation, MSP-TS430xxx, MSP-FET430Uxx, FET430F6137RF900, EM430Fx1x7RF900	19
1.18 Hardware Installation, eZ430-XXXX, MSP-EXP430G2, MSP-EXP430FR5739, MSPEXP430F5529	19
1.19 Important MSP430 Documents on the Web	19

1.1 Kit Contents, MSP-TS430xx

- One READ ME FIRST document
- One 32.768-kHz crystal from Micro Crystal (except MSP-TS430PW24)
- One target socket module
- A 2x7-pin male JTAG connector is also present on the PCB (see different setup for L092)
- MSP430 device samples (see [Table 1-1](#) for sample type)

Table 1-1. Individual Kit Contents, MSP-TS430xx

Part Number	Socket Type	Supported Devices	Included Devices	Headers and Comment
MSP-TS430D8 (green PCB)	8-pin D (TSSOP ZIF)	MSP430G2210, MSP430G2230	1 x MSP430G2210ID and 1 x MSP430G2230ID	Two PCB 1x4-pin headers (two male and two female)
MSP-TS430PW14 (green PCB)	14-pin PW (TSSOP ZIF)	MSP430F20xx, MSP430G2x01, MSP430G2x11, MSP430G2x21, MSP430G2x31	2 x MSP430F2013IPW	Four PCB 1x7-pin headers (two male and two female)
MSP-TS430L092 (green PCB)	14-pin PW (TSSOP ZIF)	MSP-TS430L092	2 x MSP430L092IPW	Four PCB 1x7-pin headers (two male and two female). A "Micro-MaTch" 10-pin female connector is also present on the PCB which connects the kit with an 'Active Cable' PCB; this 'Active Cable' PCB is connected by 14-pin JTAG cable with the FET430UIF
MSP-TS430PW20 (green PCB)	20-pin PW (TSSOP ZIF)	MSP430FR2311PW20, MSP430FR2311PW16	None. Free samples can be ordered in the TI Store .	Four PCB 1x12-pin headers (two male and two female)
MSP-TS430PW24 (green PCB)	24-pin PW (TSSOP ZIF)	MSP430AFE2xx	2 x MSP430AFE253IPW	Four PCB 1x12-pin headers (two male and two female)
MSP-TS430RGE24A (red PCB)	24-pin RGE (QFN ZIF)	MSP430FR2433IRGE	None. Free samples can be ordered in the TI Store .	Four PCB 1x6-pin headers (two male and two female)
MSP-TS430DW28 (green PCB)	28-pin DW (SSOP ZIF)	MSP430F11x1, MSP430F11x2, MSP430F12x, MSP430F12x2, MSP430F21xx Supports devices in 20- and 28-pin DA packages	2 x MSP430F123IDW	Four PCB 1x12-pin headers (two male and two female)
MSP-TS430PW28 (green PCB)	28-pin PW (TSSOP ZIF)	MSP430F11x1, MSP430F11x2, MSP430F12x, MSP430F12x2, MSP430F21xx	2 x MSP430F2132IPW	Four PCB 1x12-pin headers (two male and two female)
MSP-TS430PW28A (red PCB)	28-pin PW (TSSOP ZIF)	MSP430F20xx, MSP430G2xxx in 14-, 20-, and 28-pin PW packages, MSP430TCH5E in PW package	2 x MSP430G2452IPW20	Four PCB 1x12-pin headers (two male and two female)
MSP-TS430RHB32A (red PCB)	32-pin RHB (QFN ZIF)	MSP430i204x	2 x MSP430i2041TRHB	Eight PCB 1x8-pin headers (four male and four female)
MSP-TS430DA38 (green PCB)	38-pin DA (TSSOP ZIF)	MSP430F22xx, MSP430G2x44, MSP430G2x55	2 x MSP430F2274IDA 2 x MSP430G2744IDA 2 x MSP430G2955IDA	Four PCB 1x19-pin headers (two male and two female)
MSP-TS430QFN23x0 (green PCB)	40-pin RHA (QFN ZIF)	MSP430F23x0	2 x MSP430F2370IRHA	Eight PCB 1x10-pin headers (four male and four female)
MSP-TS430RSB40 (green PCB)	40-pin RSB (QFN ZIF)	MSP430F51x1, MSP430F51x2	2 x MSP430F5172IRSB	Eight PCB 1x10-pin headers (four male and four female)
MSP-TS430RHA40A (red PCB)	40-pin RHA (QFN ZIF)	MSP430FR572x, MSP430FR573x	2 x MSP430FR5739IRHA	Eight PCB 1x10-pin headers (four male and four female)
MSP-TS430DL48 (green PCB)	48-pin DL (TSSOP ZIF)	MSP430F42x0	2 x MSP430F4270IDL	Four PCB 2x12-pin headers (two male and two female)
MSP-TS430RGZ48B (blue PCB)	48-pin RGZ (QFN ZIF)	MSP430F534x	2 x MSP430F5342IRGZ	Eight PCB 1x12-pin headers (four male and four female)
MSP-TS430RGZ48C (black PCB)	48-pin RGZ (QFN ZIF)	MSP430FR58xx and MSP430FR59xx	2 x MSP430FR5969IRGZ	Eight PCB 1x12-pin headers (four male and four female)
MSP-TS430PM64 (green PCB)	64-pin PM (QFP ZIF)	MSP430F13x, MSP430F14x, MSP430F14x1, MSP430F15x, MSP430F16x, MSP430F16x1, MSP430F23x, MSP430F24x, MSP430F24xx, MSP430F261x, MSP430F41x, MSP430F42x, MSP430F42xA, MSP430FE42x, MSP430FE42xA, MSP430FE42x2, MSP430FW42x	TS Kit: 2 x MSP430F2618IPM; FET Kit: 2 x MSP430F417IPM and 2 x MSP430F169IPM	Eight PCB 1x16-pin headers (four male and four female)

Table 1-1. Individual Kit Contents, MSP-TS430xx (continued)

Part Number	Socket Type	Supported Devices	Included Devices	Headers and Comment
MSP-TS430PM64A (red PCB)	64-pin PM (QFP ZIF)	MSP430F41x2	2 x MSP430F4152IPM	Eight PCB 1x16-pin headers (four male and four female)
MSP-TS430PM64D (white PCB)	64-pin PM (QFP ZIF)	MSP430FR413x, MSP430FR203x	2 x MSP430FR4133IPM	Eight PCB 1x16-pin headers (four male and four female)
MSP-TS430PM64F (purple PCB)	64-pin PM (QFP ZIF)	MSP430FR6972	None. Free samples can be ordered in the TI Store .	Eight PCB 1x16-pin headers (four male and four female)
MSP-TS430RGC64B (blue PCB)	64-pin RGC (QFN ZIF)	MSP430F530x	2 x MSP430F5310IRGC	Eight PCB 1x16-pin headers (four male and four female)
MSP-TS430RGC64C (black PCB)	64-pin RGC (QFN ZIF)	MSP430F522x, MSP430F521x, MSP430F523x, MSP430F524x, MSP430F525x	2 x MSP430F5229IRGC	Eight PCB 1x16-pin headers (four male and four female)
MSP-TS430RGC64USB (green PCB)	64-pin RGC (QFN ZIF)	MSP430F550x, MSP430F551x, MSP430F552x	2 x MSP430F5510IRGC or 2 x MSP430F5528IRGC	Eight PCB 1x16-pin headers (four male and four female)
MSP-TS430PN80 (green PCB)	80-pin PN (QFP ZIF)	MSP430F241x, MSP430F261x, MSP430F43x, MSP430F43x1, MSP430FG43x, MSP430F47x, MSP430FG47x	2 x MSP430FG439IPN	Eight PCB 1x20-pin headers (four male and four female)
MSP-TS430PN80A (red PCB)	80-pin PN (QFP ZIF)	MSP430F532x	2 x MSP430F5329IPN	Eight PCB 1x20-pin headers (four male and four female)
MSP-TS430PN80USB (green PCB)	80-pin PN (QFP ZIF)	MSP430F552x, MSP430F551x	2 x MSP430F5529IPN	Eight PCB 1x20-pin headers (four male and four female)
MSP-TS430PZ100 (green PCB)	100-pin PZ (QFP ZIF)	MSP430F43x, MSP430F43x1, MSP430F44x, MSP430FG461x, MSP430F47xx	2 x MSP430FG4619IPZ	Eight PCB 1x25-pin headers (four male and four female)
MSP-TS430PZ100A (red PCB)	100-pin PZ (QFP ZIF)	MSP430F471xx	2 x MSP430F47197IPZ	Eight PCB 1x25-pin headers (four male and four female)
MSP-TS430PZ100B (blue PCB)	100-pin PZ (QFP ZIF)	MSP430F67xx	2 x MSP430F6733IPZ	Eight PCB 1x25-pin headers (four male and four female)
MSP-TS430PZ100C (black PCB)	100-pin PZ (QFP ZIF)	MSP430F645x, MSP430F643x, MSP430F535x, MSP430F533x	2 x MSP430F6438IPZ	Eight PCB 1x25-pin headers (four male and four female)
MSP-TS430PZ100D (white PCB)	100-pin PZ (QFP ZIF)	MSP430FR698x(1), MSP430FR688x(1)	2 x MSP430FR6989IPZ	Eight PCB 1x25-pin headers (four male and four female)
MSP-TS430PZ5x100 (green PCB)	100-pin PZ (QFP ZIF)	MSP430F543x, MSP430BT5190, MSP430SL5438A	2 x MSP430F5438IPZ	Eight PCB 1x25-pin headers (four male and four female)
MSP-TS430PZ100USB (green PCB)	100-pin PZ (QFP ZIF)	MSP430F665x, MSP430F663x, MSP430F563x	2 x MSP430F6638IPZ	Eight PCB 1x25-pin headers (four male and four female)
MSP-TS430PZ100AUSB (blue PCB)	100-pin PZ (QFP ZIF)	MSP430FG662x, MSP430FG642x	None. Free samples can be ordered in the TI Store .	Eight PCB 1x25-pin headers (four male and four female)
MSP-TS430PEU128 (green PCB)	128-pin PEU (QFP ZIF)	MSP430F677x, MSP430F676x, MSP430F674x, MSP430F677x1, MSP430F676x1, MSP430F674x1	2 x MSP430F67791IPEU	Four PCB 1x26-pin headers (two male and two female) and four PCB 1x38-pin headers (two male and two female)

See the device data sheets for device specifications. Device errata can be found in the respective device product folder on the web provided as a PDF document. Depending on the device, errata may also be found in the device bug database at www.ti.com/sc/cgi-bin/buglist.cgi.

1.2 Kit Contents, MSP-FET430xx

- One READ ME FIRST document
- One MSP-FET430UIF USB interface module. This is the unit that has a USB B-connector on one end of the case, and a 2x7-pin male connector on the other end of the case.
- One USB cable
- One 32.768-kHz crystal from Micro Crystal, if the board has an option to use the quartz.
- A 2x7-pin male JTAG connector is also present on the PCB (see different setup for L092)
- One 14-Pin JTAG conductor cable
- One small box containing two MSP430 device samples (See table for Sample Type)
- One target socket module. To determine the devices used for each board and a summary of the board, see [Table 1-1](#). The name of MSP-TS430xx board can be derived from the name of the MSP-FET430xx kit; for example, the MSP-FET430U28A kit contains the MSP-TS430PW28A board.

Refer to the device data sheets for device specifications. Device errata can be found in the respective device product folder on the web provided as a PDF document. Depending on the device, errata may also be found in the device bug database at www.ti.com/sc/cgi-bin/buglist.cgi.

1.3 Kit Contents, MSP-FET

- One READ ME FIRST document
- One MSP-FET interface module
- One USB cable
- One 14-conductor cable

1.4 Kit Contents, MSP-FET430UIF

- One READ ME FIRST document
- One MSP-FET430UIF interface module
- One USB cable
- One 14-conductor cable

1.5 Kit Contents, MSP-FET430PIF

- One READ ME FIRST document
- One MSP-FET430PIF interface module
- One 25-conductor cable
- One 14-conductor cable

NOTE: This part is obsolete and is not recommended to use in new design.

1.6 Kit Contents, eZ430-F2013

- One QUICK START GUIDE document
- One eZ430-F2013 development tool including one MSP430F2013 target board

1.7 Kit Contents, eZ430-T2012

- Three MSP430F2012-based target boards

1.8 Kit Contents, eZ430-RF2500

- One QUICK START GUIDE document
- One eZ430-RF2500 CD-ROM
- One eZ430-RF2500 development tool including one MSP430F2274 and CC2500 target board
- One eZ430-RF2500T target board
- One AAA battery pack with expansion board (batteries included)

1.9 Kit Contents, eZ430-RF2500T

- One eZ430-RF2500T target board
- One AAA battery pack with expansion board (batteries included)

1.10 Kit Contents, eZ430-RF2500-SEH

- One MSP430 development tool CD containing documentation and development software
- One eZ430-RF USB debugging interface
- Two eZ430-RF2500T wireless target boards
- One SEH-01 solar energy harvester board
- One AAA battery pack with expansion board (batteries included)

1.11 Kit Contents, eZ430-Chronos-xxx**'433, '868, '915**

- One QUICK START GUIDE document
- One ez430-Chronos emulator
- One screwdriver
- Two spare screws

eZ430-Chronos-433:

- One 433-MHz eZ430-Chronos watch (battery included)
- One 433-MHz eZ430-Chronos access point

eZ430-Chronos-868:

- One 868-MHz eZ430-Chronos watch (battery included)
- One 868-MHz eZ430-Chronos access point

eZ430-Chronos-915:

- One 915-MHz eZ430-Chronos watch (battery included)
- One 915-MHz eZ430-Chronos access point

1.12 Kit Contents, FET430F6137RF900

- One READ ME FIRST document
- One legal notice
- One MSP-FET430UIF interface module
- Two EM430F6137RF900 target socket modules. This is the PCB on which is soldered a CC430F6137 device in a 64-pin RGC package. A 2x7-pin male connector is also present on the PCB.
- Two CC430EM battery packs
- Four AAA batteries
- Two 868-MHz or 915-MHz antennas
- Two 32.768-kHz crystals
- 18 PCB 2x4-pin headers
- One USB cable
- One 14-pin JTAG conductor cable

1.13 Kit Contents, EM430Fx1x7RF900

- One READ ME FIRST document
 - One legal notice
 - Two target socket module
- MSP-EM430F5137RF900:** Two EM430F5137RF900 target socket modules. This is the PCB on which is soldered a CC430F5137 device in a 48-pin RGZ package. A 2x7-pin male connector is also present on the PCB
- MSP-EM430F6137RF900:** Two EM430F6137RF900 target socket modules. This is the PCB on which is soldered a CC430F6137 device in a 64-pin RGC package. A 2x7-pin male connector is also present on the PCB
- MSP-EM430F6147RF900:** Two EM430F6147RF900 target socket modules. This is the PCB on which is soldered a CC430F6147 device in a 64-pin RGC package. A 2x7-pin male connector is also present on the PCB
- Two CC430EM battery packs
 - Four AAA batteries
 - Two 868- or 915-MHz antennas
 - Two 32.768-kHz crystals
 - 18 PCB 2x4-pin headers

1.14 Hardware Installation, MSP-FET

Follow these steps to install the hardware for the MSP-FET tool:

1. Install the IDE (CCS or IAR) that you plan to use before connecting MSP-FET to PC. During IDE installation, USB drivers are installed automatically. Make sure to use the latest IDE version, otherwise the USB drivers might not be able to recognize the MSP-FET.
2. Connect the MSP-FET to a USB port on the PC with the provided USB cable.
3. The following procedure applies to operation under Windows:
 - (a) After connecting to the PC, the MSP-FET should be recognized automatically, as the USB device driver has been already installed together with the IDE.
 - (b) If the driver has not been installed yet, the Found New Hardware wizard starts. Follow the instructions and point the wizard to the driver files.
 - (c) The default location for CCS is `c:\ti\ccsv6\ccs_base\emulation\drivers\msp430\USB_CDC`.
 - (d) The default location for IAR Embedded Workbench is `<Installation Root>\Embedded Workbench x.x\430\drivers\<Win_OS>`.
4. After connecting to a PC, the MSP-FET performs a self-test. If the self-test passes successfully, the green LED stays on. For a complete list of LED signals, please refer to the MSP-FET chapter in this document.
5. Connect the MSP-FET to a target board, such as an MSP-TS430xxx target socket module, with the 14-conductor cable.
6. Make sure that the MSP430 device is securely seated in the socket and that its pin 1 (indicated with a circular indentation on the top surface) aligns with the "1" mark on the PCB.

1.15 Hardware Installation, MSP-FET430UIF

Follow these steps to install the hardware for the MSP-FET430UIF tool:

1. Install the IDE (CCS or IAR) you plan to use before connecting USB-FET interface to PC. The IDE installation installs drivers automatically.
2. Use the USB cable to connect the USB-FET interface module to a USB port on the PC. The USB FET should be recognized, as the USB device driver is installed automatically. If the driver has not been installed yet, the install wizard starts. Follow the prompts and point the wizard to the driver files.
 The default location for CCS is `c:\ti\ccsv5\ccs_base\emulation\drivers\msp430\USB_CDC` or `c:\ti\ccsv5\ccs_base\emulation\drivers\msp430\USB_FET_XP_XX`, depending of firmware version of the tool.
 The default location for IAR Embedded Workbench is `<Installation Root>\Embedded Workbench x.x\430\drivers\TIUSBFET\ez430-UART` or `<Installation Root>\Embedded Workbench x.x\430\drivers\<Win_OS>`, depending of firmware version of the tool.
 The USB driver is installed automatically. Detailed driver installation instructions can be found in [Appendix C](#).
3. After connecting to a PC, the USB FET performs a self-test during which the red LED may flash for approximately two seconds. If the self-test passes successfully, the green LED stays on.
4. Use the 14-conductor cable to connect the USB-FET interface module to a target board, such as an MSP-TS430xxx target socket module.
5. Ensure that the MSP430 device is securely seated in the socket, and that its pin 1 (indicated with a circular indentation on the top surface) aligns with the "1" mark on the PCB.
6. Compared to the parallel-port debug interface, the USB FET has additional features including JTAG security fuse blow and adjustable target V_{CC} (1.8 V to 3.6 V). Supply the module with up to 60 mA.

1.16 Hardware Installation, MSP-FET430PIF

Follow these steps to install the hardware for the MSP-FET430PIF tools:

1. Use the 25-conductor cable to connect the FET interface module to the parallel port of the PC. The necessary driver for accessing the PC parallel port is installed automatically during CCS or IAR Embedded Workbench installation. Note that a restart is required after the CCS or IAR Embedded Workbench installation for the driver to become active.
2. Use the 14-conductor cable to connect the parallel-port debug interface module to a target board, such as an MSP-TS430xxx target socket module. Module schematics and PCBs are shown in [Appendix B](#).

1.17 Hardware Installation, MSP-TS430xxx, MSP-FET430Uxx, FET430F6137RF900, EM430Fx1x7RF900

Follow these steps to install the hardware for the MSP-FET430Uxx and MSP-TS430xxx tools:

1. Follow steps 1 and 2 of [Section 1.15](#)
2. Connect the MSP-FET430PIF or MSP-FET430UIF debug interface to the appropriate port of the PC. Use the 14-conductor cable to connect the FET interface module to the supplied target socket module.
3. Ensure that the MSP430 device is securely seated in the socket and that its pin 1 (indicated with a circular indentation on the top surface) aligns with the "1" mark on the PCB.
4. Ensure that the two jumpers (LED and VCC) near the 2x7-pin male connector are in place. Illustrations of the target socket modules and their parts are found in [Appendix B](#).

1.18 Hardware Installation, eZ430-XXXX, MSP-EXP430G2, MSP-EXP430FR5739, MSPEXP430F5529

To install the eZ430-XXXX, MSP-EXP430G2, MSP-EXP430FR5739, MSP-EXP430F5529 tools, follow steps 1 and 2 of [Section 1.15](#)

1.19 Important MSP430 Documents on the Web

The primary sources of MSP430 information are the device-specific data sheet and user's guide. The MSP430 website (www.ti.com/msp430) contains the most recent version of these documents.

PDF documents describing the CCS tools (CCS IDE, the assembler, the C compiler, the linker, and the librarian) are in the msp430\documentation folder. A Code Composer Studio specific [Wiki page \(FAQ\)](#) is available, and the Texas Instruments [E2E Community support forums](#) for the MSP430 and Code Composer Studio v5 provide additional help besides the product help and Welcome page.

PDF documents describing the IAR tools (Workbench C-SPY, the assembler, the C compiler, the linker, and the librarian) are in the common\doc and 430\doc folders. Supplements to the documents (that is, the latest information) are available in HTML format in the same directories. A IAR specific [Wiki Page](#) is also available.

Design Considerations for In-Circuit Programming

This chapter presents signal requirements for in-circuit programming of the MSP430.

Topic	Page
2.1 Signal Connections for In-System Programming and Debugging	21
2.2 External Power.....	25
2.3 Bootloader (BSL).....	25

2.1 Signal Connections for In-System Programming and Debugging

MSP-FET430PIF, MSP-FET430UIF, MSP-GANG, MSP-GANG430, MSP-PRGS430

With the proper connections, the debugger and an FET hardware JTAG interface (such as the MSP-FET430PIF and MSP-FET430UIF) can be used to program and debug code on the target board. In addition, the connections also support the MSP-GANG430 or MSP-PRGS430 production programmers, thus providing an easy way to program prototype boards, if desired.

[Figure 2-1](#) shows the connections between the 14-pin FET interface module connector and the target device required to support in-system programming and debugging for 4-wire JTAG communication.

[Figure 2-2](#) shows the connections for 2-wire JTAG mode (Spy-Bi-Wire). The 4-wire JTAG mode is supported on most MSP430 devices, except devices with low pin counts (for example, MSP430G2230). The 2-wire JTAG mode is available on selected devices only. See the *Code Composer Studio for MSP430 User's Guide* ([SLAU157](#)) or *IAR Embedded Workbench Version 3+ for MSP430 User's Guide* ([SLAU138](#)) for information on which interface method can be used on which device.

The connections for the FET interface module and the MSP-GANG, MSP-GANG430, or MSP-PRGS430 are identical. Both the FET interface module and MSP-GANG430 can supply V_{CC} to the target board (through pin 2). In addition, the FET interface module, MSP-GANG, and MSP-GANG430 have a V_{CC} -sense feature that, if used, requires an alternate connection (pin 4 instead of pin 2). The V_{CC} -sense feature senses the local V_{CC} present on the target board (that is, a battery or other local power supply) and adjusts the output signals accordingly. If the target board is to be powered by a local V_{CC} , then the connection to pin 4 on the JTAG should be made, and not the connection to pin 2. This uses the V_{CC} -sense feature and prevents any contention that might occur if the local on-board V_{CC} were connected to the V_{CC} supplied from the FET interface module, MSP-GANG or the MSP-GANG430. If the V_{CC} -sense feature is not necessary (that is, if the target board is to be powered from the FET interface module, MSP-GANG, or MSP-GANG430), the V_{CC} connection is made to pin 2 on the JTAG header, and no connection is made to pin 4. [Figure 2-1](#) and [Figure 2-2](#) show a jumper block that supports both scenarios of supplying V_{CC} to the target board. If this flexibility is not required, the desired V_{CC} connections may be hard-wired to eliminate the jumper block. Pins 2 and 4 must not be connected at the same time.

The connection to the JTAG connector \overline{RST} pin of [Figure 2-1](#) is required when programming or debugging a device that supports 2-wire JTAG communication, even when using 4-wire JTAG communication mode on these devices. However, this connection is optional on devices that do not support 2-wire JTAG communication. The MSP430 development tools and device programmers perform a target reset by issuing a JTAG command to gain control over the device. However, if this is unsuccessful, the RST signal of the JTAG connector may be used by the development tool or device programmer as an additional way to assert a device reset.

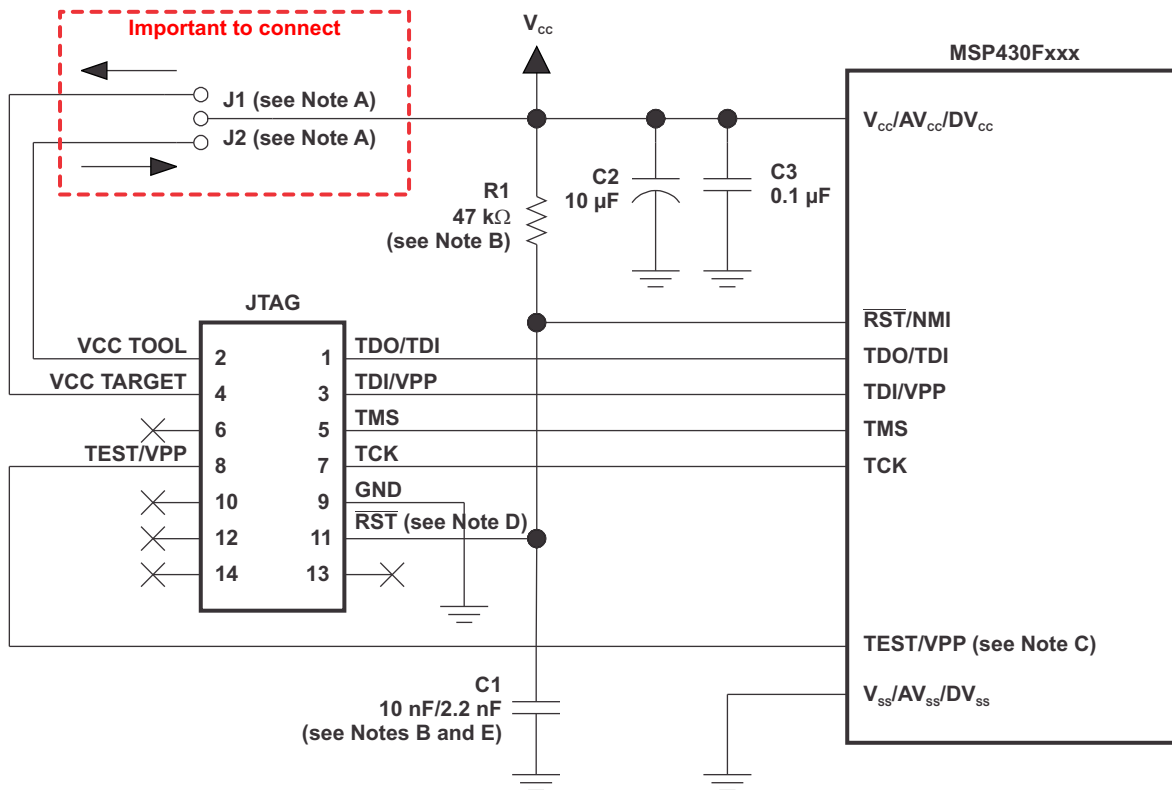

- A If a local target power supply is used, make connection J1. If power from the debug or programming adapter is used, make connection J2.
- B The configuration of R1 and C1 for the $\overline{\text{RST}}/\text{NMI}$ pin depends on the device family. See the respective MSP430 family user's guide for the recommended configuration.
- C The TEST pin is available only on MSP430 family members with multiplexed JTAG pins. See the device-specific data sheet to determine if this pin is available.
- D The connection to the JTAG connector $\overline{\text{RST}}$ pin is required when programming or debugging a device that supports 2-wire JTAG communication, even when using 4-wire JTAG communication mode on these devices. However, this connection is optional on devices that do not support 2-wire JTAG communication.
- E When using a device that supports 2-wire JTAG communication in 4-wire JTAG mode, the upper limit for C1 should not exceed 2.2 nF. This applies to both TI FET interface modules (LPT and USB FET). Some EVMs use a value of 1.1 nF to enable high-speed SBW communication.

Figure 2-1. Signal Connections for 4-Wire JTAG Communication

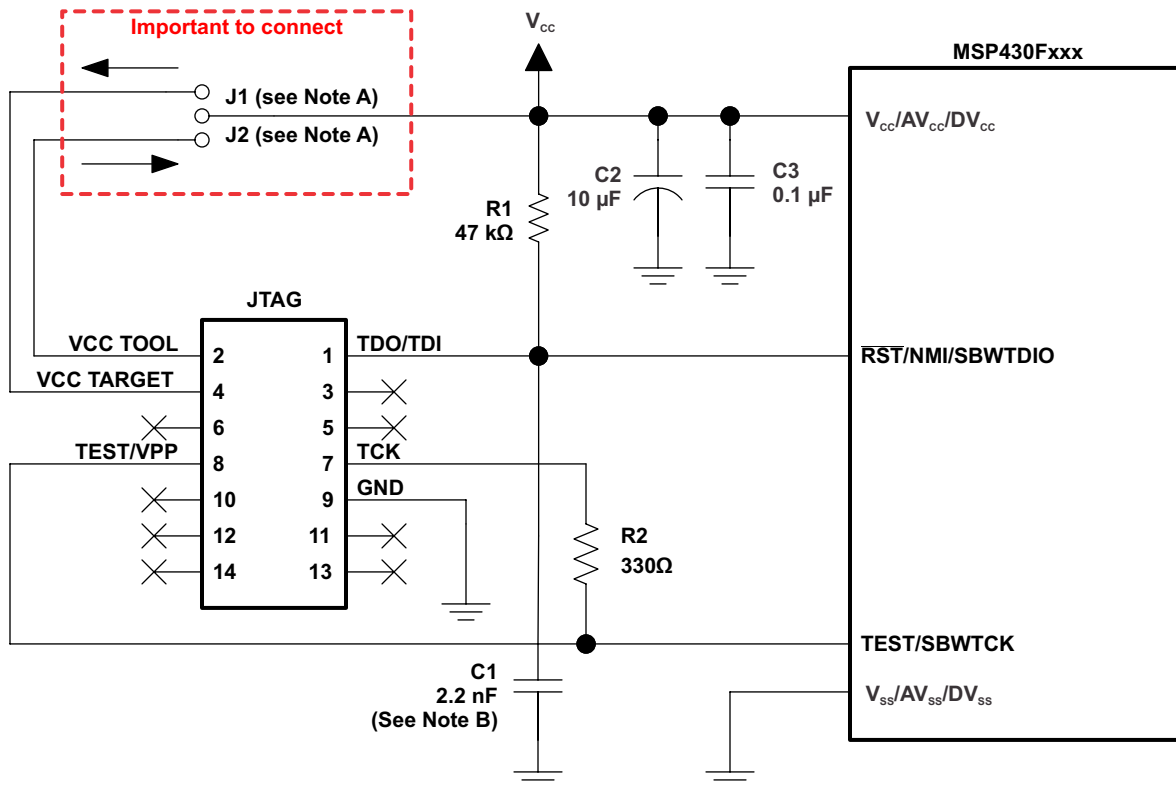

- A If a local target power supply is used, make connection J1. If power from the debug or programming adapter is used, make connection J2.
- B The device $\overline{\text{RST}}/\text{NMI}/\text{SBWT DIO}$ pin is used in 2-wire mode for bidirectional communication with the device during JTAG access, and any capacitance that is attached to this signal may affect the ability to establish a connection with the device. The upper limit for C1 is 2.2 nF when using current TI tools. Some EVMs use a value of 1.1 nF to enable high-speed SBW communication.
- C R2 protects the JTAG debug interface TCK signal from the JTAG security fuse blow voltage that is supplied by the TEST/VPP pin during the fuse blow process. If fuse blow functionality is not needed, R2 is not required (populate 0 Ω) and do not connect TEST/VPP to TEST/SBWTCK.

Figure 2-2. Signal Connections for 2-Wire JTAG Communication (Spy-Bi-Wire) Used by MSP430F2xx, MSP430G2xx, and MSP430F4xx Devices

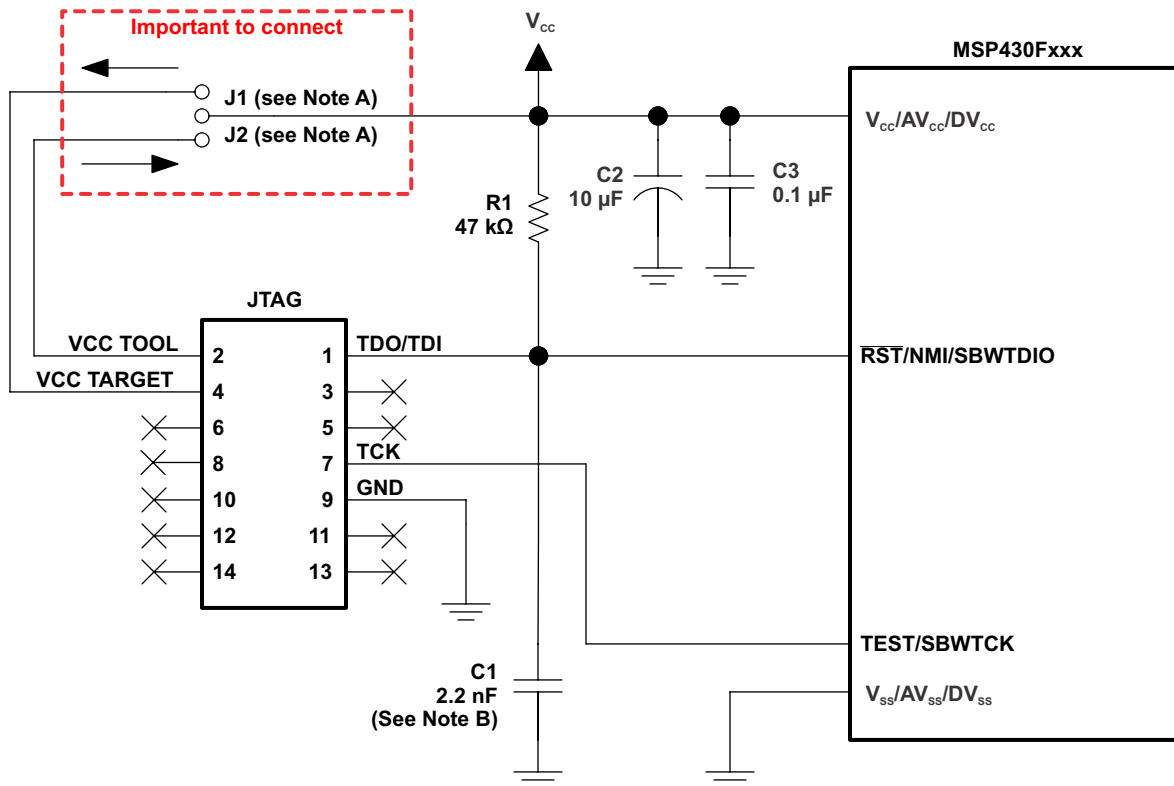

- A Make connection J1 if a local target power supply is used, or make connection J2 if the target is powered from the debug or programming adapter.
- B The device $\overline{\text{RST/NMI/SBWT DIO}}$ pin is used in 2-wire mode for bidirectional communication with the device during JTAG access, and any capacitance that is attached to this signal may affect the ability to establish a connection with the device. The upper limit for C1 is 2.2 nF when using current TI tools. Some EVMs use a value of 1.1 nF to enable high-speed SBW communication.

Figure 2-3. Signal Connections for 2-Wire JTAG Communication (Spy-Bi-Wire) Used by All MSP430 SBW-Capable Devices That are Not Part of F2xx, G2xx, F4xx Families

NOTE: On some Spy-Bi-Wire capable MSP430 devices, TEST/SBWTCK is very sensitive to rising signal edges that can cause the test logic to enter a state where an entry sequence (either 2-wire or 4-wire) is not recognized correctly and JTAG access stays disabled. Unintentional edges on SBWTCK can occur when the JTAG connector is connected to the target device.

2.2 External Power

The MSP-FET430UIF can supply targets with up to 60 mA through pin 2 of the 14-pin connector. Note that the target should not consume more than 60 mA, even as a peak current, as it may violate the USB specification. For example, if the target board has a capacitor on V_{CC} more than 10 μ F, it may cause inrush current during capacitor charging that may exceed 60 mA. In this case, the current should be limited by the design of the target board, or an external power supply should be used.

The V_{CC} for the target can be selected between 1.8 V and 3.6 V in steps of 0.1 V. Alternatively, the target can be supplied externally. In this case, the external voltage should be connected to pin 4 of the 14-pin connector. The MSP-FET430UIF then adjusts the level of the JTAG signals to external V_{CC} automatically. Only pin 2 (MSP-FET430UIF supplies target) or pin 4 (target is externally supplied) must be connected; not both at the same time.

When a target socket module is powered from an external supply, the external supply powers the device on the target socket module and any user circuitry connected to the target socket module, and the FET interface module continues to be powered from the PC through the parallel port. If the externally supplied voltage differs from that of the FET interface module, the target socket module must be modified so that the externally supplied voltage is routed to the FET interface module (so that it may adjust its output voltage levels accordingly). See the target socket module schematics in [Appendix B](#).

The PC parallel port can source a limited amount of current. Because of the ultra-low-power requirement of the MSP430, a stand-alone FET does not exceed the available current. However, if additional circuitry is added to the tool, this current limit could be exceeded. In this case, external power can be supplied to the tool through connections provided on the target socket modules. See the schematics and pictorials of the target socket modules in [Appendix B](#) to locate the external power connectors. Note that the MSP-FET430PIF is not recommended for new design.

2.3 Bootloader (BSL)

The JTAG pins provide access to the memory of the MSP430 and CC430 devices. On some devices, these pins are shared with the device port pins, and this sharing of pins can complicate a design (or sharing may not be possible). As an alternative to using the JTAG pins, most MSP430Fxxx devices contain a program (a "bootloader", formerly known as the "bootstrap loader") that permits the flash memory to be erased and programmed using a reduced set of signals. The *MSP430 Programming With the Bootloader (BSL) User's Guide* ([SLAU319](#)) describes this interface. See the [MSP430 website](#) for the application reports and a list of MSP430 BSL tool developers.

TI suggests that MSP430Fxxx customers design their circuits with the BSL in mind (that is, TI suggests providing access to these signals by, for example, a header).

See FAQ [Hardware #10](#) for a second alternative to sharing the JTAG and port pins.

Frequently Asked Questions and Known Issues

This appendix presents solutions to frequently asked questions regarding the MSP-FET430 hardware.

Topic	Page
A.1 Hardware FAQs	27
A.2 Known Issues	29

A.1 Hardware FAQs

1. MSP430F22xx Target Socket Module (MSP-TS430DA38) – Important Information

Due to the large capacitive coupling introduced by the device socket between the adjacent signals XIN/P2.6 (socket pin 6) and $\overline{\text{RST}}$ /SBWTDIO (socket pin 7), in-system debugging can disturb the LFXT1 low-frequency crystal oscillator operation (ACLK). This behavior applies only to the Spy-Bi-Wire (2-wire) JTAG configuration and only to the period while a debug session is active.

Workarounds:

- Use the 4-wire JTAG mode debug configuration instead of the Spy-Bi-Wire (2-wire) JTAG configuration. This can be achieved by placing jumpers JP4 through JP9 accordingly.
 - Use the debugger option "Run Free" that can be selected from the Advanced Run drop-down menu (at top of Debug View). This prevents the debugger from accessing the MSP430 device while the application is running. Note that, in this mode, a manual halt is required to see if a breakpoint was hit. See the IDE documentation for more information on this feature.
 - Use an external clock source to drive XIN directly.
2. **With current interface hardware and software, there is a weakness when adapting target boards that are powered externally.** This leads to an accidental fuse check in the MSP430 device. This is valid for PIF and UIF but is seen most often on the UIF. A solution is being developed.
- Workarounds:
- Connect the $\overline{\text{RST}}$ /NMI pin to the JTAG header (pin 11). LPT and USB tools are able to pull the RST line, which also resets the device internal fuse logic.
 - Use the debugger option "Release JTAG On Go" that can be selected from the IDE drop-down menu. This prevents the debugger from accessing the MCU while the application is running. Note that in this mode, a manual halt is required to see if a breakpoint was hit. See the IDE documentation for more information on this feature.
 - Use an external clock source to drive XIN directly.
3. The 14-conductor **cable** that connects the FET interface module and the target socket module **must not exceed 8 inches (20 centimeters) in length.**
4. The signal assignment on the **14-conductor cable** is **identical** for the **parallel port interface** and the **USB FET.**
5. **To use the on-chip ADC voltage references, the capacitor must be installed** on the target socket module. See the schematic of the target socket module to populate the capacitor according to the data sheet of the device.
6. **To use the charge pump on the devices with LCD+ Module, the capacitor must be installed** on the target socket module. See the schematic of the target socket module to populate the capacitor according to the data sheet of the device.
7. **Crystals or resonators Q1 and Q2 (if applicable) are not provided on the target socket module.** For MSP430 devices that contain user-selectable loading capacitors, see the device and crystal data sheets for the value of capacitance.
8. **Crystals or resonators have no effect upon the operation of the tool and the CCS debugger or C-SPY** (as any required clocking and timing is derived from the internal DCO and FLL).
9. **On devices with multiplexed port or JTAG pins,** to use these pin in their port capability:
For CCS: "Run Free" (in Run pulldown menu at top of Debug View) must be selected.
For C-SPY: "Release JTAG On Go" must be selected.
10. **As an alternative to sharing the JTAG and port pins** (on low pin count devices), **consider using an MSP430 device that is a "superset" of the smaller device.** A very powerful feature of the MSP430 is that the family members are code and architecturally compatible, so code developed on one device (for example, one without shared JTAG and port pins) ports effortlessly to another (assuming an equivalent set of peripherals).

11. **Information memory may not be blank** (erased to 0xFF) when the device is delivered from TI. Customers should erase the information memory before its first use. Main memory of packaged devices is blank when the device is delivered from TI.
 12. **The device current is higher than expected.** The device current measurement may not be accurate with the debugger connected to the device. For accurate measurement, disconnect the debugger. Additionally some unused pins of the device should be terminated. See the *Connection of Unused Pins* table in the device's family user's guide.
 13. The following **ZIF sockets** are used in the FET tools and target socket modules:
 - 8-pin device (D package): Yamaichi IC369-0082
 - 14-pin device (PW package): Enplas OTS-14-065-01
 - 14-pin package for 'L092 (PW package): Yamaichi IC189-0142-146
 - 24-pin package (PW package): Enplas OTS-24(28)-0.65-02
 - 28-pin device (DW package): Wells-CTI 652 D028
 - 28-pin device (PW package): Enplas OTS-28-0.65-01
 - 38-pin device (DA package): Yamaichi IC189-0382-037
 - 40-pin device (RHA package): Enplas QFN-40B-0.5-01
 - 40-pin device (RSB package): Enplas QFN-40B-0.4
 - 48-pin device (RGZ package): Yamaichi QFN11T048-008 A101121-001
 - 48-pin device (DL package): Yamaichi IC51-0482-1163
 - 64-pin device (PM package): Yamaichi IC51-0644-807
 - 64-pin device (RGC package): Yamaichi QFN11T064-006
 - 80-pin device (PN package): Yamaichi IC201-0804-014
 - 100-pin device (PZ package): Yamaichi IC201-1004-008
 - 128-pin device (PEU package): Yamaichi IC500-1284-009P
- Enplas: www.enplas.com
Wells-CTI: www.wellscti.com
Yamaichi: www.yamaichi.us

A.2 Known Issues

MSP-FET430UIF *Current detection algorithm of the UIF firmware*

Problem Description If high current is detected, the I_{CC} monitor algorithm stays in a loop of frequently switching on and off the target power supply. This power switching puts some MSP430 devices such as the MSP430F5438 in a state that requires a power cycle to return the device to JTAG control.

A side issue is that if the UIF firmware has entered this switch on and switch off loop, it is not possible to turn off the power supply to the target by calling MSP430_VCC(0). A power cycle is required to remove the device from this state.

Solution IAR KickStart and Code Composer Essentials that have the MSP430.dll version 2.04.00.003 and higher do not show this problem. Update the software development tool to this version or higher to update the MSP-FET430UIF firmware.

MSP-FET430PIF *Some PCs do not supply 5 V through the parallel port*

Problem Description Device identification problems with modern PCs, because the parallel port often does not deliver 5 V as was common with earlier hardware.

1. When connected to a laptop, the test signal is clamped to 2.5 V.
2. When the external V_{CC} becomes less than 3 V, up to 10 mA is flowing in the adapter through pin 4 (sense).

Solution Measure the voltage level of the parallel port. If it is too low, provide external 5 V to the V_{CC} pads of the interface. The jumper on a the target socket must be switched to external power.

Hardware

This appendix contains information relating to the FET hardware, including schematics, PCB pictorials, and bills of materials (BOMs). All other tools, such as the eZ430 series, are described in separate product-specific user's guides.

Topic	Page
B.1 MSP-TS430D8	32
B.2 MSP-TS430PW14	35
B.3 MSP-TS430L092	38
B.4 MSP-TS430L092 Active Cable	41
B.5 MSP-TS430PW20	44
B.6 MSP-TS430PW24	48
B.7 MSP-TS430RGE24A	51
B.8 MSP-TS430DW28	54
B.9 MSP-TS430PW28	57
B.10 MSP-TS430PW28A	60
B.11 MSP-TS430RHB32A	63
B.12 MSP-TS430DA38	66
B.13 MSP-TS430QFN23x0	69
B.14 MSP-TS430RSB40	72
B.15 MSP-TS430RHA40A	75
B.16 MSP-TS430DL48	78
B.17 MSP-TS430RGZ48B	81
B.18 MSP-TS430RGZ48C	84
B.19 MSP-TS430PM64	87
B.20 MSP-TS430PM64A	90
B.21 MSP-TS430PM64D	93
B.22 MSP-TS430PM64F	96
B.23 MSP-TS430RGC64B	99
B.24 MSP-TS430RGC64C	102
B.25 MSP-TS430RGC64USB	106
B.26 MSP-TS430PN80	110
B.27 MSP-TS430PN80A	113
B.28 MSP-TS430PN80USB	116
B.29 MSP-TS430PZ100	120
B.30 MSP-TS430PZ100A	123
B.31 MSP-TS430PZ100B	126
B.32 MSP-TS430PZ100C	129
B.33 MSP-TS430PZ100D	132
B.34 MSP-TS430PZ5x100	135
B.35 MSP-TS430PZ100USB	138
B.36 MSP-TS430PZ100AUSB	142
B.37 MSP-TS430PEU128	146
B.38 EM430F5137RF900	149
B.39 EM430F6137RF900	153
B.40 EM430F6147RF900	157
B.41 MSP-FET	161
B.42 MSP-FET430UIF	173
B.43 MSP-FET430PIF	179

B.1 MSP-TS430D8

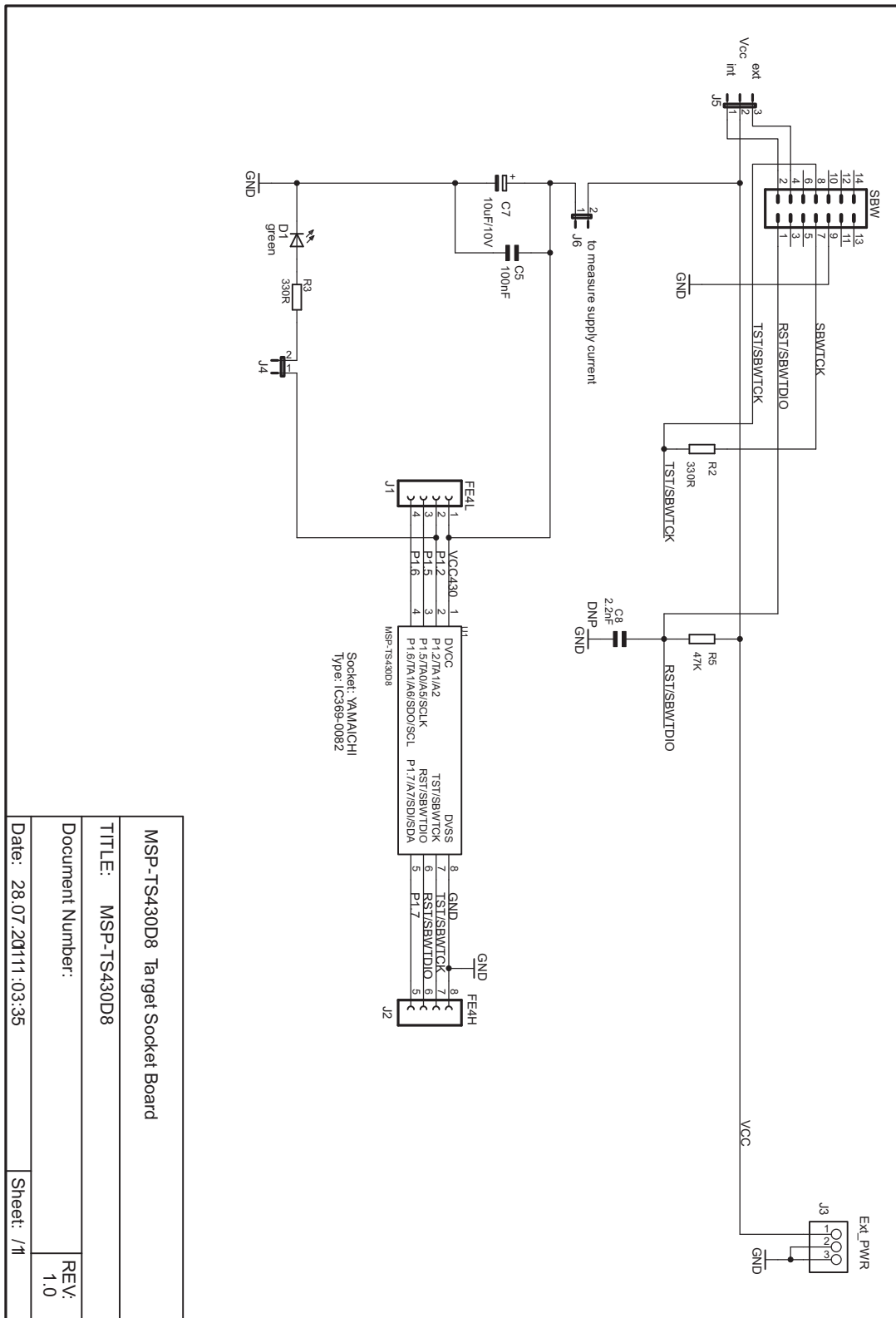

Figure B-1. MSP-TS430D8 Target Socket Module, Schematic

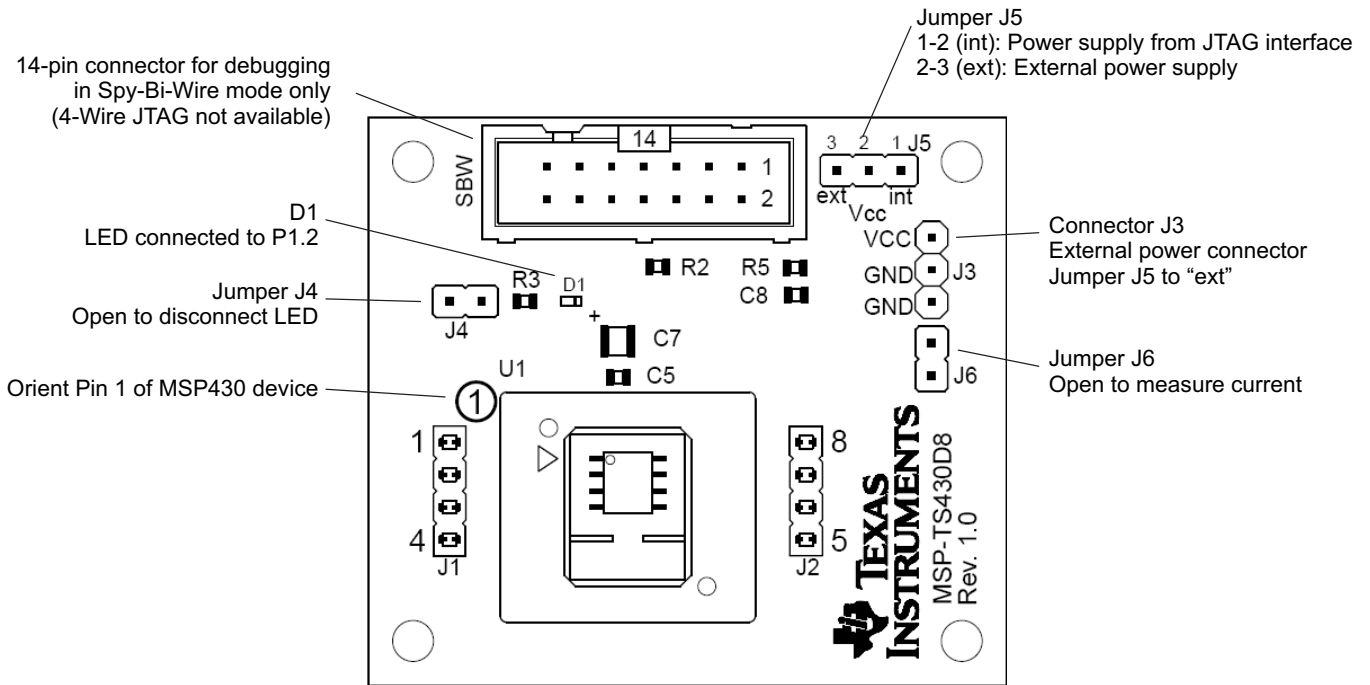

Figure B-2. MSP-TS430D8 Target Socket Module, PCB

Table B-1. MSP-TS430D8 Bill of Materials

Position	Ref Des	No. per Board	Description	Digi-Key Part No.	Comment
1	J4, J6	2	2-pin header, male, TH	SAM1035-02-ND	place jumper on header
2	J5	1	3-pin header, male, TH	SAM1035-03-ND	place jumper on pins 1-2
3	SBW	1	10-pin connector, male, TH	HRP10H-ND	
4	J3	1	3-pin header, male, TH	SAM1035-03-ND	
5	C8	1	2.2nF, CSMD0805	Buerklin 53 D 292	
6	C7	1	10uF, 10V, 1210ELKO	478-3875-1-ND	
7	R5	1	47K, 0805	541-47000ATR-ND	
8	C5	1	100nF, CSMD0805	311-1245-2-ND	
9	R2, R3	2	330R, 0805	541-330ATR-ND	
10	J1, J2	2	4-pin header, TH	SAM1029-04-ND	DNP: headers enclosed with kit. Keep vias free of solder.
10,1	J1, J2	1	4-pin socket, TH	SAM1029-04-ND	DNP: receptacles enclosed with kit.
11	U1	1	SO8 Socket: Type IC369-0082		Manuf.: Yamaichi
12	D1	1	red, LED 0603		
13	MSP430	2	MSP430G2210, MSP430G2230		DNP: enclosed with kit. Is supplied by TI
14	PCB	1	50,0mmx44,5mm	MSP-TS430D8 Rev. 1.0	

B.2 MSP-TS430PW14

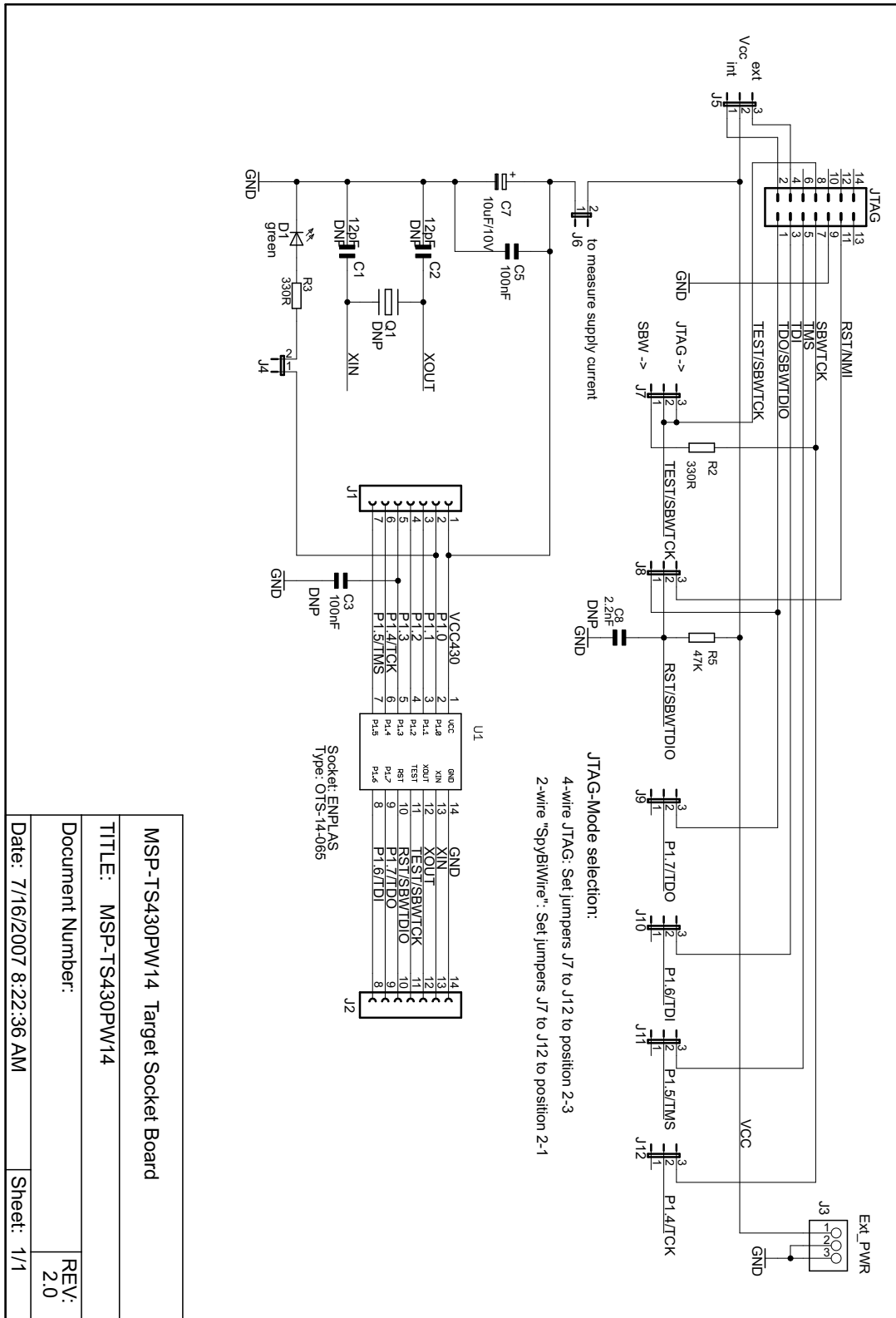

Figure B-3. MSP-TS430PW14 Target Socket Module, Schematic

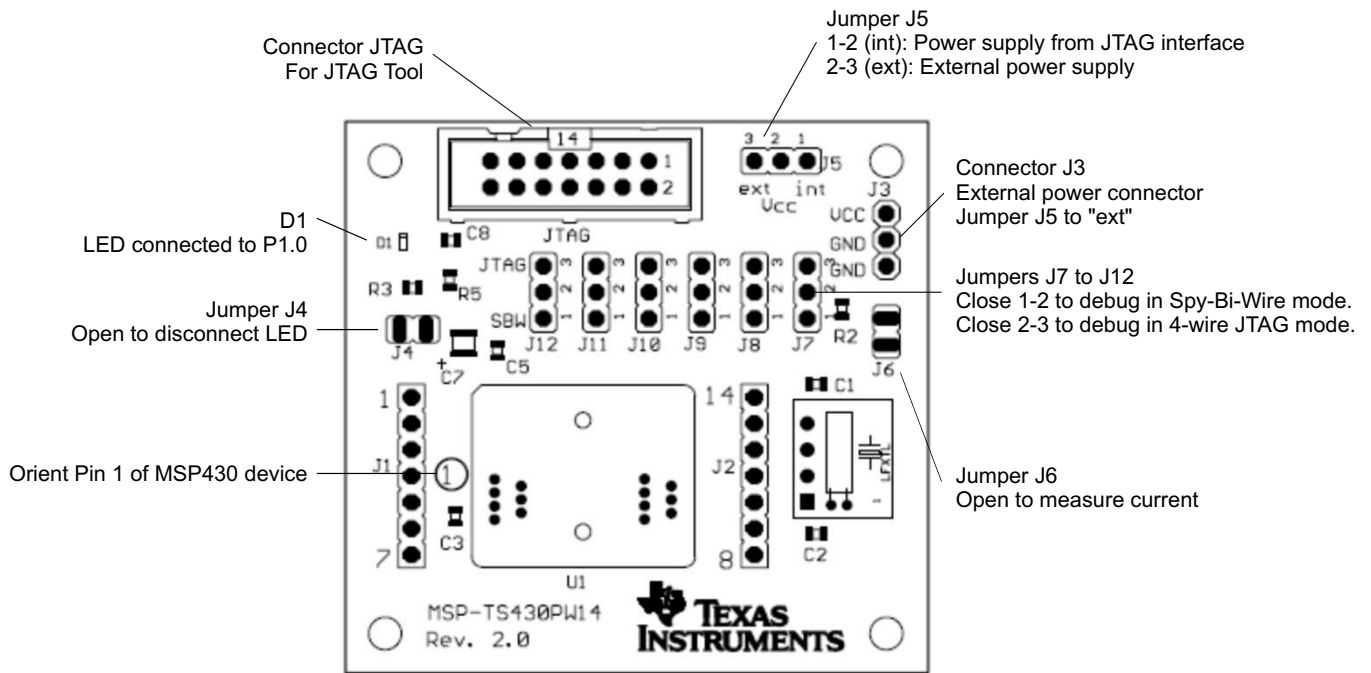

Figure B-4. MSP-TS430PW14 Target Socket Module, PCB

Table B-2. MSP-TS430PW14 Bill of Materials

Position	Ref Des	No. per Board	Description	Digi-Key Part No.	Comment
1	C1, C2	0	12pF, SMD0805		DNP
2	C7	1	10uF, 10V, Tantal Size B	511-1463-2-ND	
3	C3, C5	1	100nF, SMD0805	478-3351-2-ND	DNP: C3
4	C8	0	2.2nF, SMD0805		DNP
5	D1	1	green LED, SMD0603	475-1056-2-ND	
6	J1, J2	0	7-pin header, TH	SAM1029-07-ND SAM1213-07-ND	DNP: Headers and receptacles enclosed with kit. Keep vias free of solder : Header : Receptacle
7	J3, J5, J7, J8, J9, J10, J11, J12	8	3-pin header, male, TH	SAM1035-03-ND	Place jumpers on headers J5, J7, J8, J9, J10, J11, J12; Pos 1-2
8	J4, J6	2	2-pin header, male, TH	SAM1035-02-ND	Place jumper on header
9		9	Jumper	15-38-1024-ND	Place on: J5, J7-J12; Pos 1-2
10	JTAG	1	14-pin connector, male, TH	HRP14H-ND	
12	Q1	0	Crystal	Micro Crystal MS1V-T1K 32.768kHz, C(Load) = 12.5pF	DNP: keep vias free of solder
13	R2, R3	2	330 Ω , SMD0805	541-330ATR-ND	
15	R5	1	47k Ω , SMD0805	541-47000ATR-ND	
16	U1	1	Socket: OTS-14-0.65-01		Manuf.: Enplas
17	PCB	1	56 x 53 mm		2 layers
18	Adhesive plastic feet	4	Approximately 6mm width, 2mm height	For example, 3M Bumpons Part No. SJ- 5302	Apply to corners at bottom side
19	MSP430	2	MSP430F2013IPW		DNP: enclosed with kit, supplied by TI

B.3 MSP-TS430L092

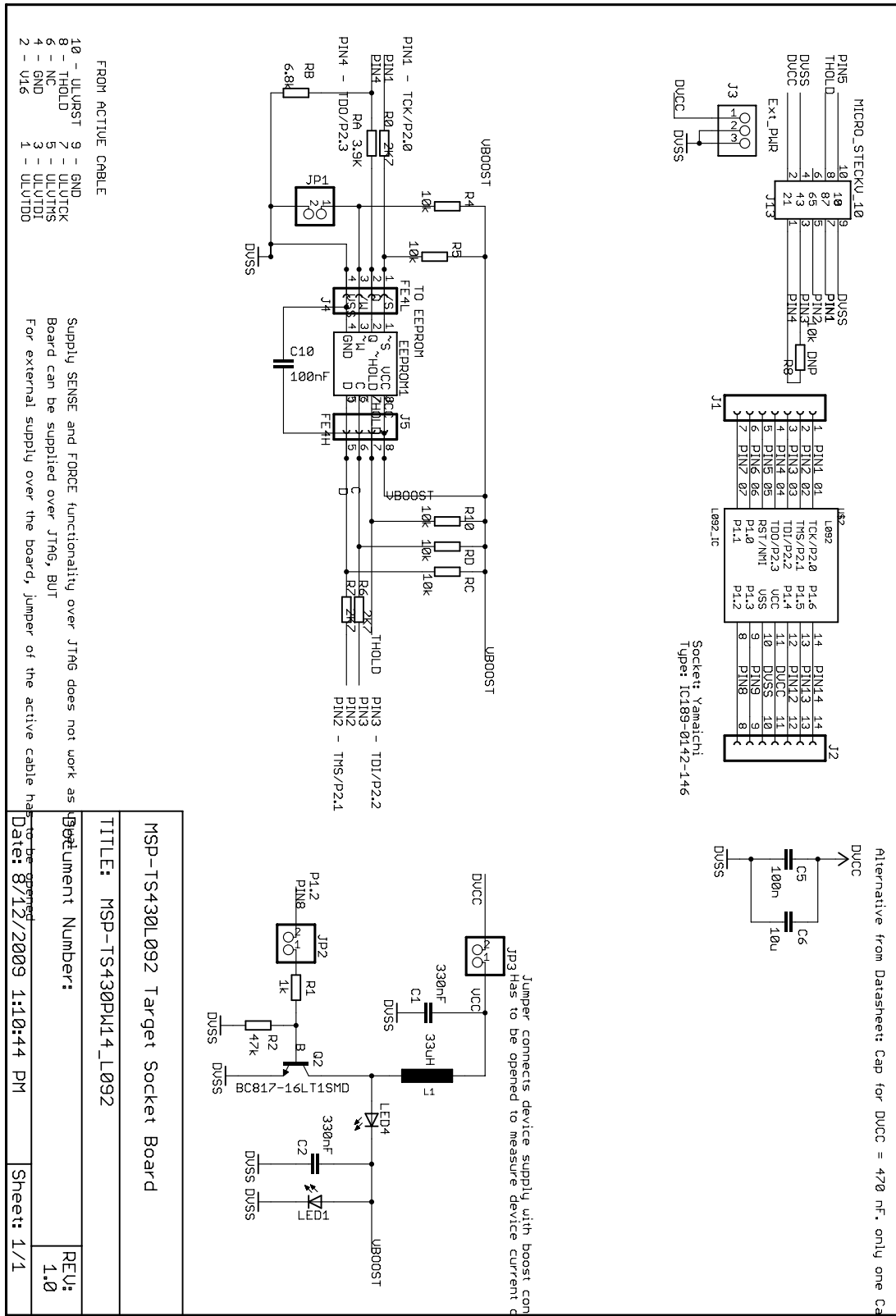

Figure B-5. MSP-TS430L092 Target Socket Module, Schematic

Settings of the MSP-TS430L092 Target Socket

Figure B-6 shows the PCB layout of the MSP-TS430L092 target socket. The following pinning is recommended:

- JP1 is write enable for the EPROM. If this is not set, the EPROM can only be read.
- JP2 and JP3 connect device supply with boost converter. They can be opened to measure device current consumption. For default operation, they should be closed.

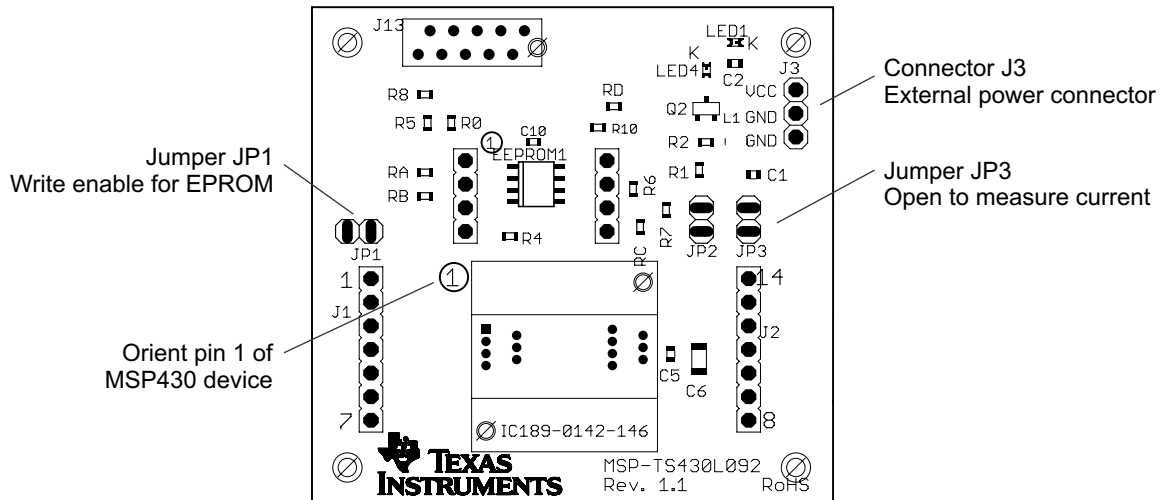

Figure B-6. MSP-TS430L092 Target Socket Module, PCB

Table B-3. MSP-TS430L092 Bill of Materials

Pos.	Ref Des No.	No. Per Board	Description	Digi-Key Part No.	Comment
1	C1, C2	2	330nF, SMD0603		
2	C5	1	100n, SMD0603		
3	C6	1	10u, SMD0805		
4	C10	1	100n, SMD0603		
5	EEPROM1	1	M95512 SO08 (SO8)	ST Micro M95160R	Digikey: 497-8688-1-ND
7	J1, J2	2	7-pin header, TH	SAM1213-07-ND SAM1035-07-ND	DNP: headers and receptacles enclosed with kit. Keep vias free of solder. : Header : Receptacle
8	J3	1	3-pin header, male, TH	SAM1035-03-ND	
9	J4, J5	2	FE4L, FE4H	4 pol. Stiftreihe	DNP; Keep vias free of solder.
11	J13	1	MICRO_STECKV_10		Reichelt: MicroMaTch-Connector: MM FL 10G
12	JP1, JP2, JP3	3	2-pin header, male, TH	SAM1035-02-ND	place jumper on header
15	L1	1	33uH, SMD0806	LQH2MCN330K02L	Farnell: 151-5557
16	LED1, LED4	2	LEDCHIPLED_0603		Farnell: 1686065
17	Q2	1	BC817-16LT1SMD	BC817-16LT1SMD	SOT23-BEC
18	R0, R6, R7	3	2K7, SMD0603		
19	R1	1	1k, SMD0603		
20	R2	1	47k, SMD0603		
21	R4, R5, R8, R10, RC, RD	6	10k, SMD0603		
22	RA	1	3.9k, SMD0603		
23	RB	1	6.8k, SMD0603		
24	U1	1	14 Pin Socket - IC189-0142-146	Manuf. Yamaichi	
22	MSP430	2	MSP430L092PWR	DNP: Enclosed with kit. Is supplied by TI.	

B.4 MSP-TS430L092 Active Cable

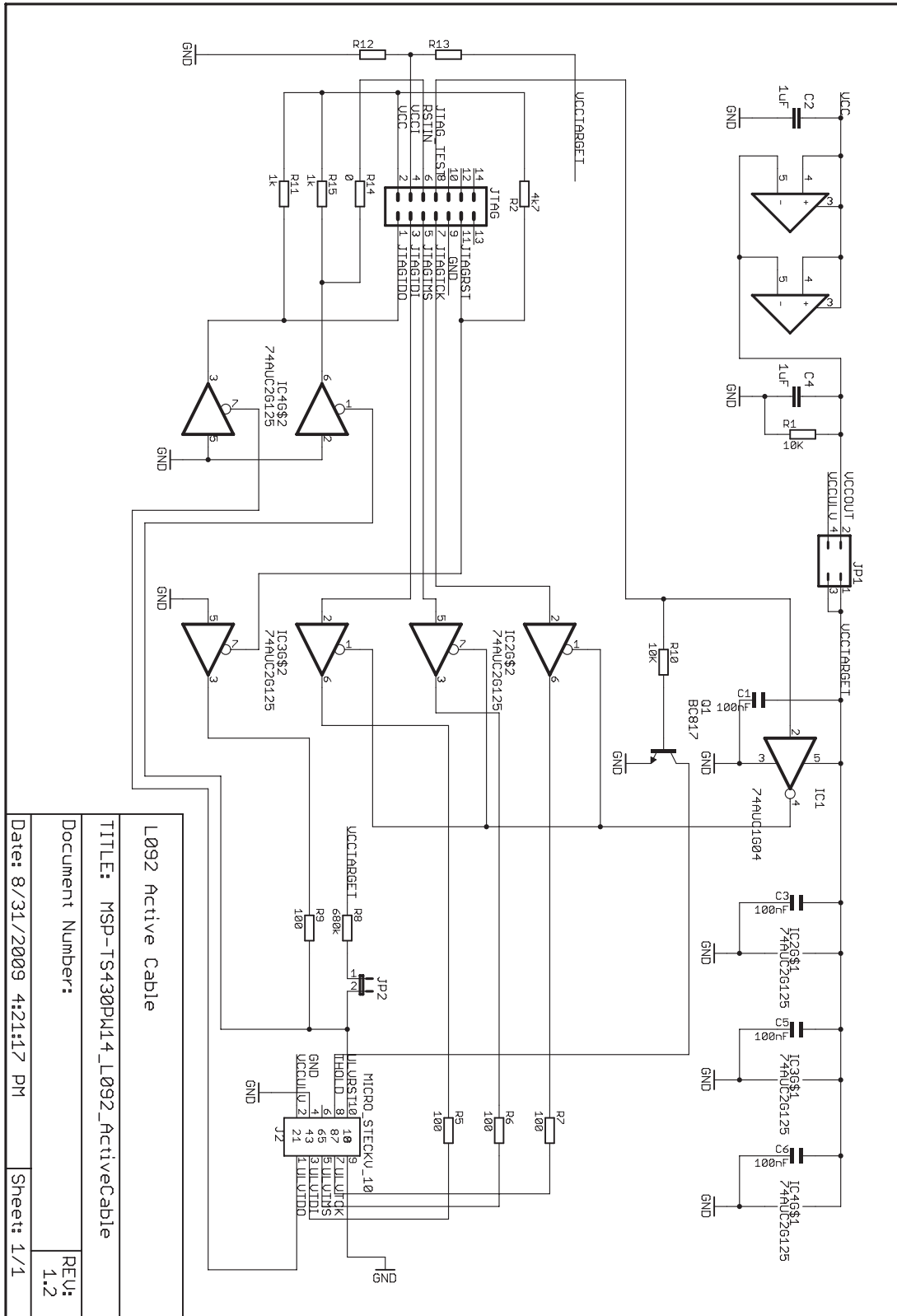

Figure B-7. MSP-TS430L092 Active Cable Target Socket Module, Schematic

Figure B-8 shows the PCB layout for the Active Cable. The following pinning is possible:

- JP1 has two jumpers (Jumper 1 and Jumper 2) that can be set as shown in Table B-4.

Table B-4. MSP-TS430L092 JP1 Settings

Jumper 1	Jumper 2	Description
Off	Off	The active cable has no power and does not function.
Off	On	The active cable receives power from target socket. For this option, the target socket must have its own power supply.
On	Off	The active cable receives power from the JTAG connector.
On	On	The JTAG connector powers the active cable and the target socket. For this option, the target socket must not have its own power source, as this would cause a not defined state.

- JP2 is for reset. For the standard MSP-TS430L092, this jumper must be set. It sets the reset pin to high and can also control it. Without this jumper on the MSP-TS430L092, reset is set to zero.

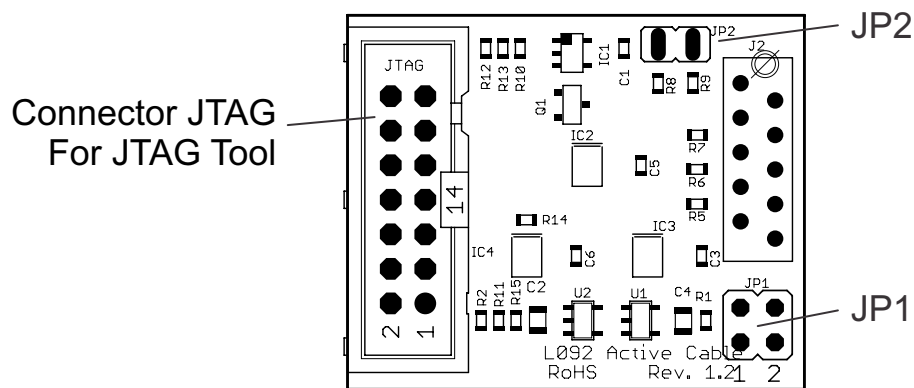

Figure B-8. MSP-TS430L092 Active Cable Target Socket Module, PCB

Table B-5. MSP-TS430L092 Active Cable Bill of Materials

Pos.	Ref Des	No. Per Board	Description	Digi-Key Part No.	Comment
1	C1, C3, C5, C6	4	100nF, SMD0603		
2	C2, C4	2	1uF, SMD0805		
3	R1, R10	2	10K, SMD0603		
4	R2	1	4K7, SMD0603		
5	R5, R6, R7, R9	4	100, SMD0603		
6	R8	1	680k, SMD0603		
7	R11, R15	2	1K, SMD0603		
8	R12	0	SMD0603		DNP
9	R13	0	SMD0603		DNP
10	R14	1	0, SMD0603		
11	IC1	1	SN74AUC1G04DBVR		Manu: TI
12	IC2, IC3, IC4	3	SN74AUC2G125DCTR		Manu: TI
13	J2	1	MICRO_STECKV_10	Reichelt: MicroMaTch-Connector: MM FL 10G	
14	JP1	1	2x2 Header	JP2Q	Put jumper on Position 1 and 2. Do not mix direction.
15	JP2	1	2-pin header, male, TH	SAM1035-02-ND	place jumper on header
16	JTAG	1	14-pin connector, male, TH	HRP14H-ND	
17	Q1	1	BC817-25LT1SMD, SOT23-BEC	Digi-Key: BC817-25LT1GOSCT-ND	
18	U1, U2	2	TLVH4311DBVR	SOT23-5	Manu: TI

B.5 MSP-TS430PW20

The MSP-TS430PW20 microcontroller development board supports the MSP430FR23x and MSP430FR21x FRAM devices in both 20-pin and 16-pin TSSOP (TI package code PW) packages. No microcontroller devices are included in the MSP-TS430PW20 kit, but can be ordered from the [TI Store](#).

The MSP-TS430PW20 microcontroller development board has two jumpers on header J11 that direct the UART BSL signals, depending on which device is being used (see [Figure B-9](#)).

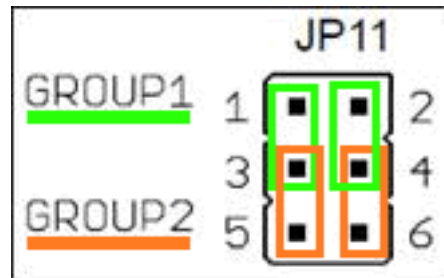

Figure B-9. UART BSL Signal Select

- GROUP2: Jumpers on 3-5 and 4-6 for MSP430FR231x PW16
- GROUP1: Jumpers on 1-3 and 2-4 for all other compatible devices, including MSP430FR231x PW20

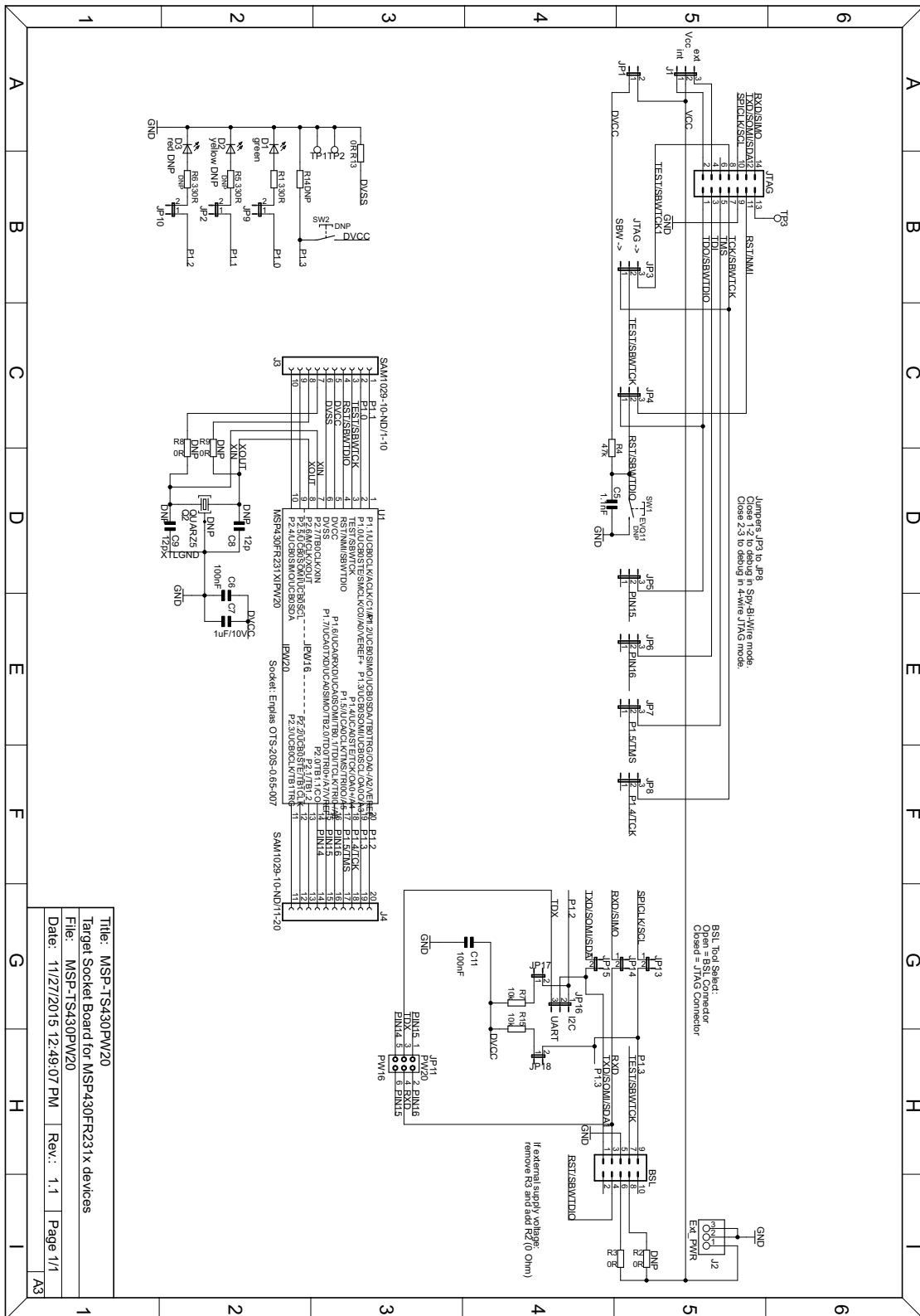

Figure B-10. MSP-TS430PW20 Target Socket Module, Schematic

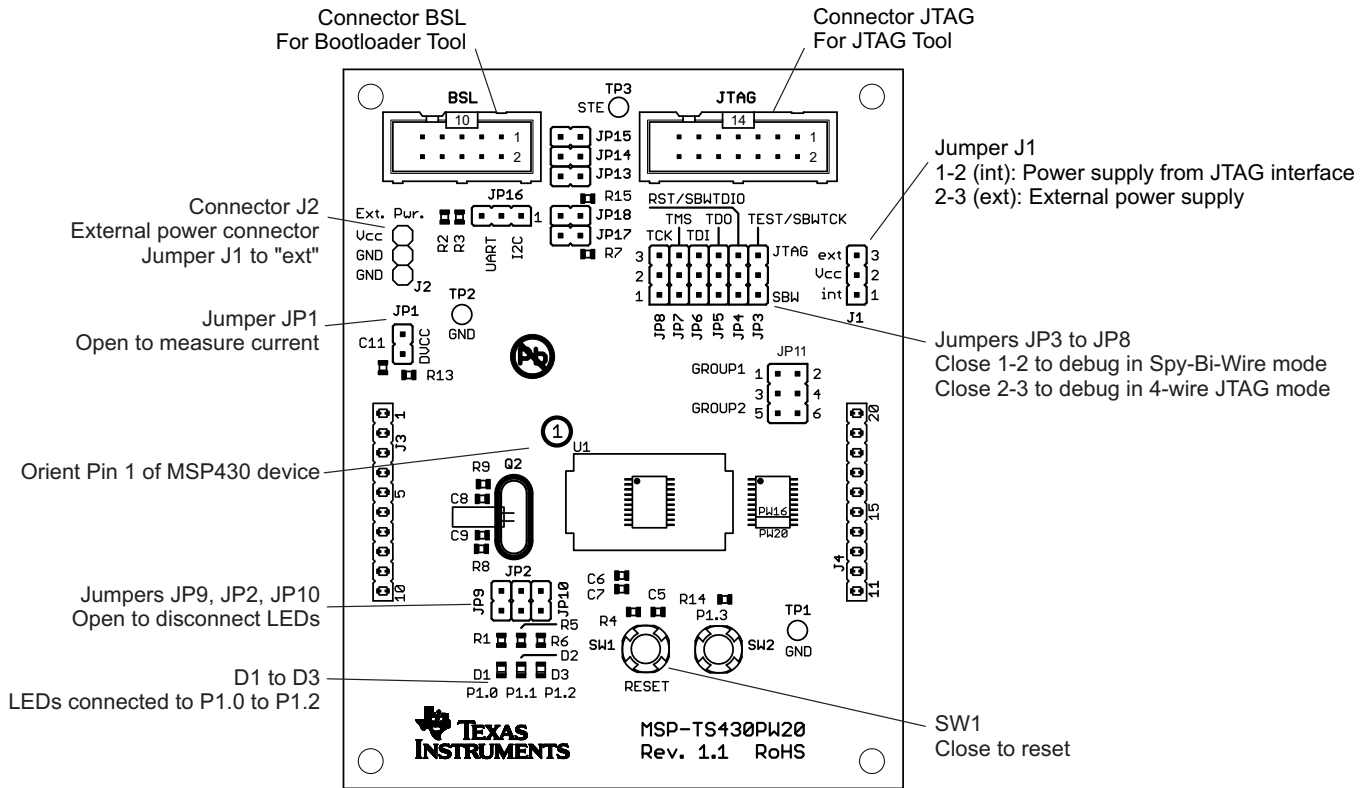

Figure B-11. MSP-TS430PW20 Target Socket Module, PCB

Table B-6. MSP-TS430PW20 Bill of Materials

Pos.	Ref Des	No. Per Board	Description	Digi-Key Part No.	Comment
1	PCB	1	90.0 x 92.5 mm	"MSP-TS430PW20" Rev. 1.1	2 layers, green solder mask
2	JP1, JP9, JP13, JP14, JP15	5	2-pin header, male, TH	SAM1035-02-ND	place jumper on header
3	JP17, JP18	2	2-pin header, male, TH	SAM1035-02-ND	place jumper on one pin only
4	JP2, JP10	2	2-pin header, male, TH	SAM1035-02-ND	DNP, keep pads free of solder
5	J1	1	3-pin header, male, TH	SAM1035-03-ND	place jumpers on pins 1-2
6	JP3, JP4, JP5, JP6, JP7, JP8	6	3-pin header, male, TH	SAM1035-03-ND	place jumpers on pins 1-2
7	JP16	1	3-pin header, male, TH	SAM1035-03-ND	place jumpers on pins 2-3
8	J2	1	3-pin header, male, TH	SAM1035-03-ND	
9	JP11	1	2x3pin header, male, TH	SAM1034-03-ND	PW20: Place jumpers on pins 1-3 and 2-4 PW16: Place jumpers on pins 3-5 and 4-6
10	R2, R8, R9	3	0R, 0805	541-0.0ATR-ND	DNP
11	R3, R13	2	0R, 0805	541-0.0ATR-ND	
12	C5	1	1.1nF, CSMD0805	490-1623-2-ND	
13	C7	1	1uF/10V, CSMD0805	490-1702-2-ND	
14	R7, R15	1	10k, 0805	541-10KATR-ND	
15	R4	1	47k, 0805	541-47KATR-ND	
16	C6, C11	2	100nF, CSMD0805	490-1666-1-ND	
17	C8, C9	2	12p, DNP, CSMD0805	BC1257TR-ND	DNP
18	R1	1	330R, 0805	541-330ATR-ND	
19	R5, R6	2	330R, 0805	541-330ATR-ND	DNP
20	R14	1	47k, 0805	541-47KATR-ND	DNP
21	SW2	1	EVQ-11L05R	P8079STB-ND	DNP, Keep vias free of solder
22	SW1	1	EVQ-11L05R	P8079STB-ND	DNP, Keep vias free of solder
23	J3, J4	2	10-pin header, TH	SAM1029-10-ND	DNP: headers are enclosed with kit. Keep vias free of solder.
24	J3, J4	2	10-pin receptacle, TH	SAM1213-10-ND	DNP: Receptacles are enclosed with kit. Keep vias free of solder.
25	TP1, TP2, TP3	3	Test point		DNP, keep pads free of solder
26	BSL	1	10-pin connector, male, TH	HRP10H-ND	
27	JTAG	1	14-pin connector, male, TH	HRP14H-ND	
28	IC1	1	Socket: OTS-20S-0.65-007		Manuf. Enplas
29	IC1	1	MSP430FR2311PW20		DNP: Free samples can be ordered in the TI Store
30	Q2	1	4MHz Crystal	4MHz Buerklin: 78D134	DNP: Crystal is enclosed with kit
31	Q2	1	MSV3V-T1R (32.768KHz / 20ppm / 12.5pF)		DNP: Crystal is enclosed with kit
32	D1	1	green LED, HSMG-C170 DIODE0805	516-1434-1-ND	Avago, Farnell 5790852
33	D3	1	red LED, DIODE0805		DNP
34	D2	1	yellow LED, DIODE0805		DNP
35	Rubber stand off	4		Buerklin: 20H1724	apply to corners at bottom side

B.6 MSP-TS430PW24

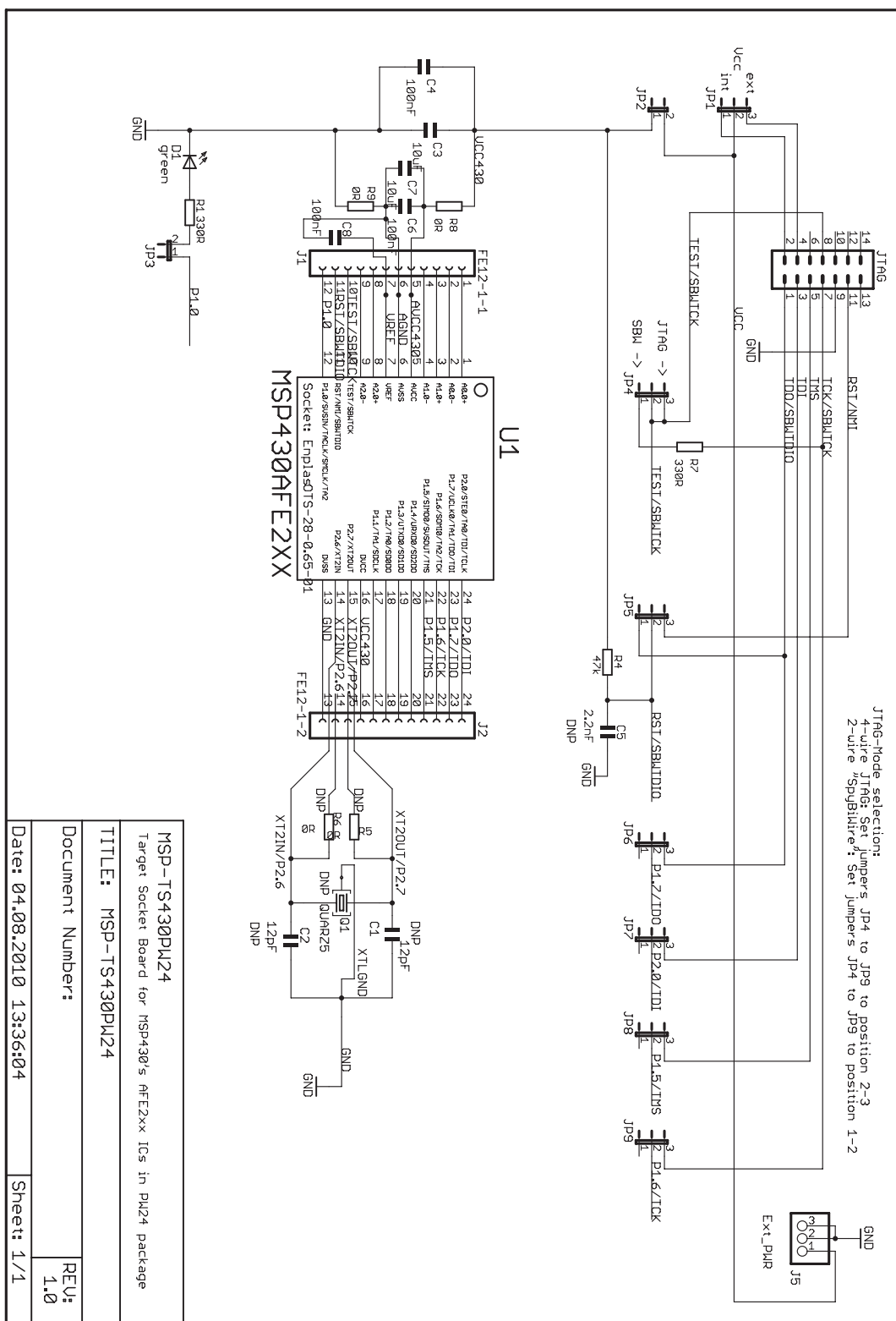

Figure B-12. MSP-TS430PW24 Target Socket Module, Schematic

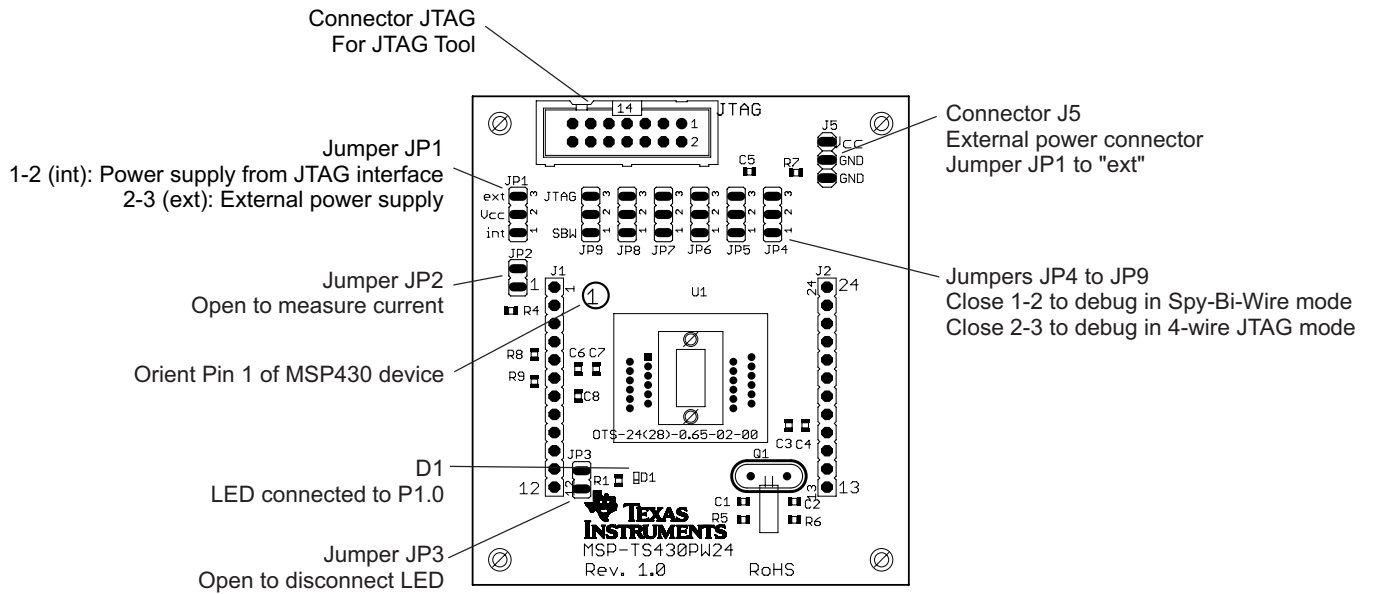

Figure B-13. MSP-TS430PW24 Target Socket Module, PCB

Table B-7. MSP-TS430PW24 Bill of Materials

Position	Ref Des	No. per Board	Description	Digi-Key Part No.	Comment
1	C1, C2	0	12pF, SMD0805		DNP
2	C5	1	2.2nF, SMD0805		
3	C3, C7	2	10uF, 10V, SMD0805		
4	C4, C6, C8	3	100nF, SMD0805	478-3351-2-ND	
5	D1	1	green LED, SMD0805	P516TR-ND	
6	J1, J2	0	12-pin header, TH	SAM1029-07-ND SAM1213-07-ND	DNP: Headers and receptacles enclosed with kit. Keep vias free of solder. (Header and Receptacle)
7	J5, JP1, JP4, JP5, JP6, JP7, JP8, JP9	8	3-pin header, male, TH	SAM1035-03-ND	Place jumper on 1-2 of JP4-JP9 Place on 1-2 on JP1
8	JP2, JP3	2	2-pin header, male, TH	SAM1035-02-ND	Place jumper on header
9		9	Jumper	15-38-1024-ND	see Pos 7 and 8
10	JTAG	1	14-pin connector, male, TH	HRP14H-ND	
11	Q1	0	Crystal		DNP: keep vias free of solder
12	R1, R7	2	330 Ω, SMD0805	541-330ATR-ND	
13	R5, R6, R8, R9	2	0 Ohm, SMD0805	541-000ATR-ND	DNP R5, R6
14	R4	1	47k Ohm, SMD0805	541-47000ATR-ND	
15	U1	1	Socket: OTS 24(28)-065-02-00		Manuf.: Enplas
16	PCB	1	68.5 x 61 mm		2 layers
17	Adhesive plastic feet	4	Approximately 6mm width, 2mm height	for example, 3M Bumpons Part No. SJ-5302	Apply to corners at bottom side
18	MSP430	2	MSP430AFE2xx		DNP: enclosed with kit, supplied by TI

B.7 MSP-TS430RGE24A

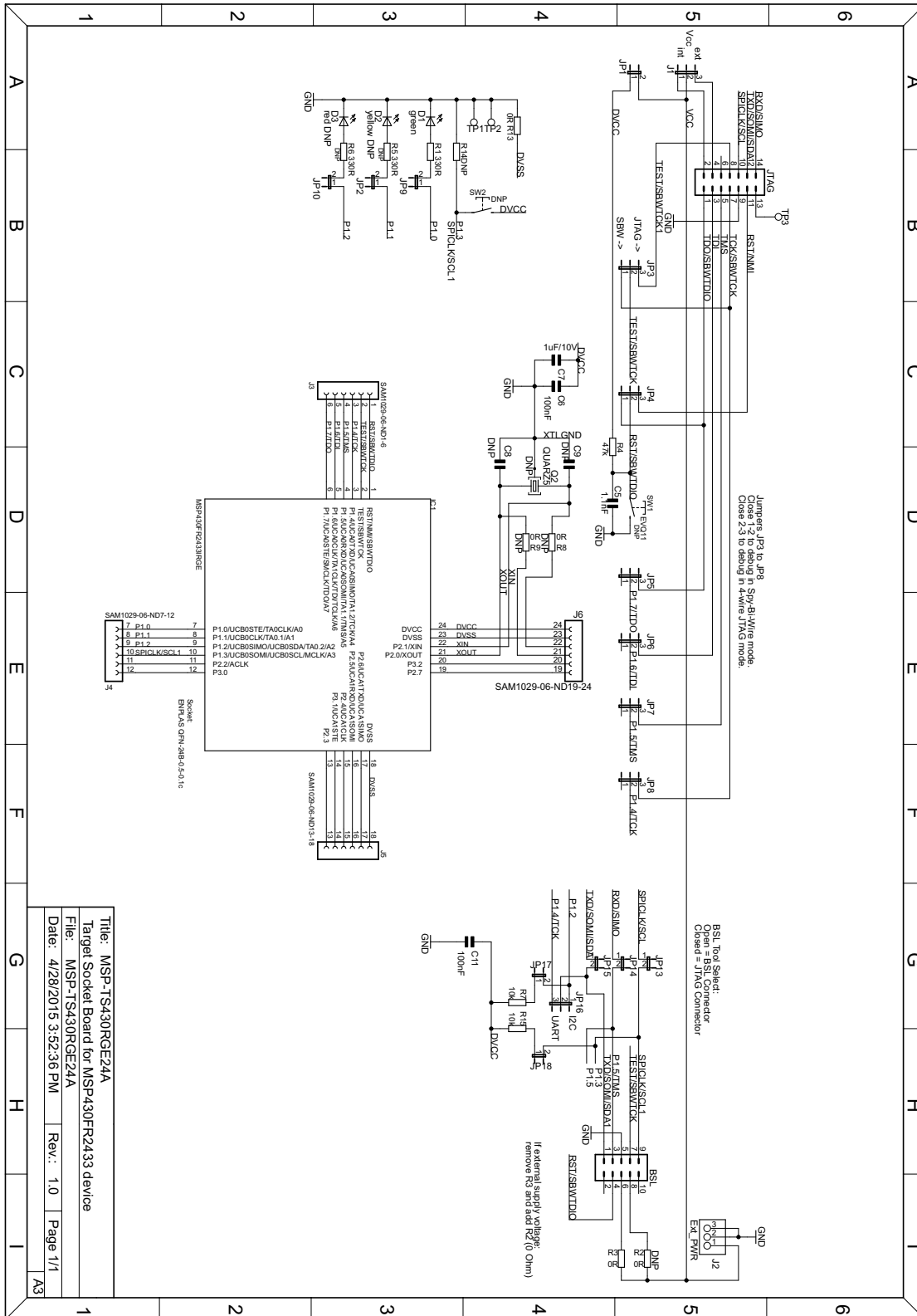

Figure B-14. MSP-TS430RGE24A Target Socket Module, Schematic

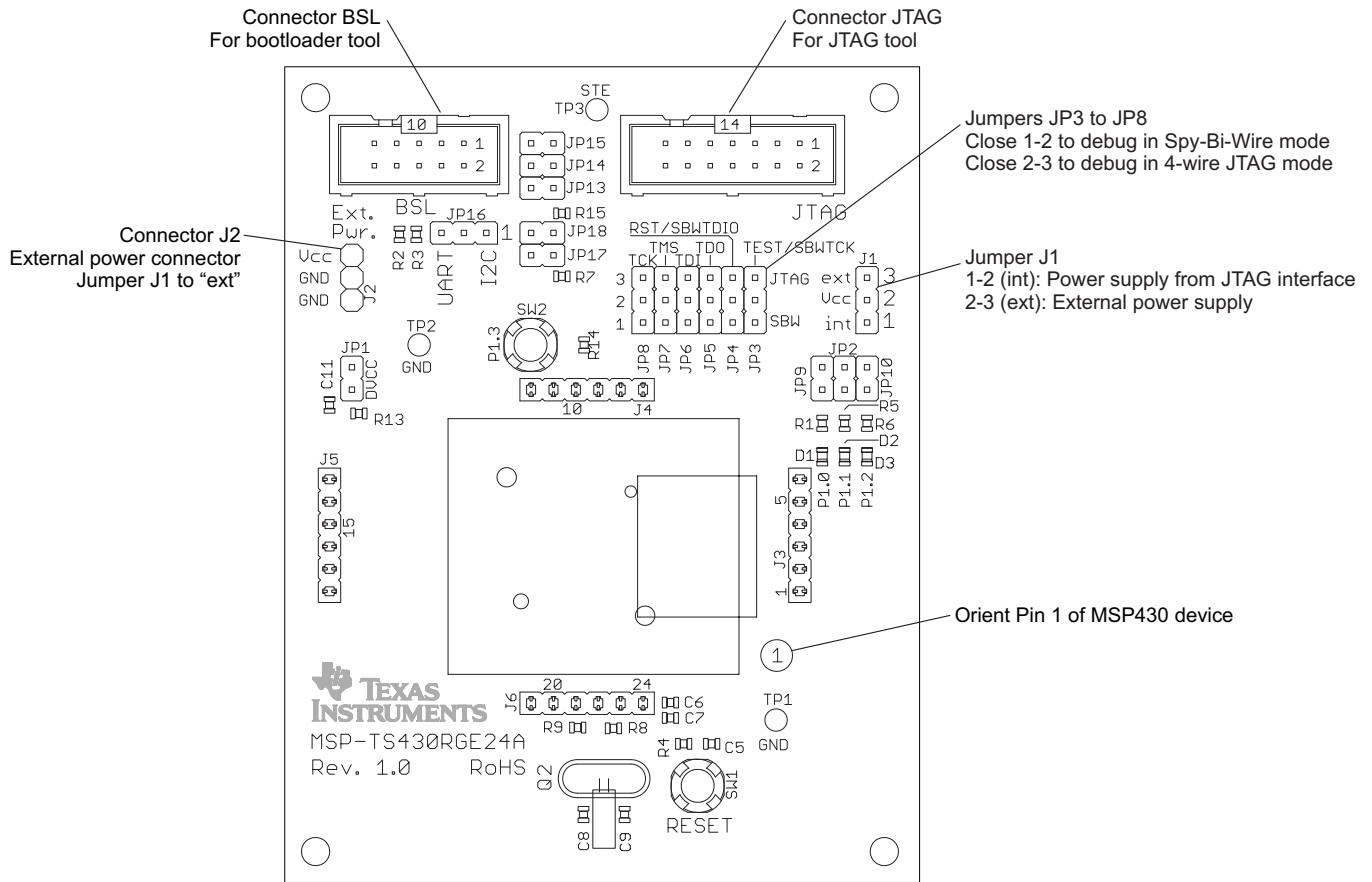

Figure B-15. MSP-TS430RGE24A Target Socket Module, PCB

Table B-8. MSP-TS430RGE24A Bill of Materials (BOM)

Position	Ref Des	No. per Board	Description	Digi-Key Part No.	Comment
1	PCB	1	90.0 x 92.5 mm	"MSP-TS430RGE24A" Rev. 1.0	2 layers, red solder mask
2	JP1, JP9, JP13, JP14, JP15	5	2-pin header, male, TH	SAM1035-02-ND	place jumper on header
3	JP17, JP18	2	2-pin header, male, TH	SAM1035-02-ND	place jumper on one pin only
4	JP2, JP10	2	2-pin header, male, TH	SAM1035-02-ND	DNP, keep pads free of solder
5	J1	1	3-pin header, male, TH	SAM1035-03-ND	place jumpers on pins 1-2
6	JP3, JP4, JP5, JP6, JP7, JP8, JP16	7	3-pin header, male, TH	SAM1035-03-ND	place jumpers on pins 2-3
7	J2	1	3-pin header, male, TH	SAM1035-03-ND	
8	R2, R8, R9	3	0R, 0805	541-0.0ATR-ND	DNP
9	R3, R13	2	0R, 0805	541-0.0ATR-ND	
10	C5	1	1.1nF, CSMD0805	490-1623-2-ND	
11	C7	1	1uF/10V, CSMD0805	490-1702-2-ND	
12	R7, R15	1	10k, 0805	541-10KATR-ND	
13	R4	1	47k, 0805	541-47KATR-ND	
14	C6, C11	2	100nF, CSMD0805	490-1666-1-ND	
15	R1	1	330R, 0805	541-330ATR-ND	
16	R5, R6	2	330R, 0805	541-330ATR-ND	DNP
17	R14	1	47k, 0805	541-47KATR-ND	DNP
18	C8, C9	2	DNP, CSMD0805		DNP
19	SW2	1	EVQ-11L05R	P8079STB-ND	DNP, Keep vias free of solder. Lacon: 1251459
20	SW1	1	EVQ-11L05R	P8079STB-ND	DNP, Keep vias free of solder. Lacon: 1251459
21	J3, J4, J5, J6	4	6-pin header, TH	SAM1029-06-ND	DNP: headers enclosed in kit. Keep vias free of solder.
22	J3, J4, J5, J6	4	6-pin receptacle, TH	SAM1213-06-ND	DNP: receptacles enclosed in kit. Keep vias free of solder.
23	TP1, TP2, TP3	3	Test point		DNP, keep pads free of solder
24	BSL	1	10-pin connector, male, TH	HRP10H-ND	
25	JTAG	1	14-pin connector, male, TH	HRP14H-ND	
26	IC1	1	Socket:QFN-24B-0.5-0.1c		Manuf. Enplas
27	IC1	1	MSP430FR2433IRGER		DNP: Free samples can be ordered in the TI Store
28	Q2	1	DNP: MS3V-TR1 (32,768kHz/ 20ppm/12,5pF)	depends on application	DNP: Micro Crystal, enclosed in kit. Keep vias free of solder
29	D1	1	green LED, HSMG-C170 DIODE0805	516-1434-1-ND	Avago, Farnell 5790852
30	D3	1	red (DNP), DIODE0805		DNP
31	D2	1	yellow (DNP), DIODE0805		DNP
32	Rubber stand off	4		Buerklin: 20H1724	Apply to corners at bottom side

B.8 MSP-TS430DW28

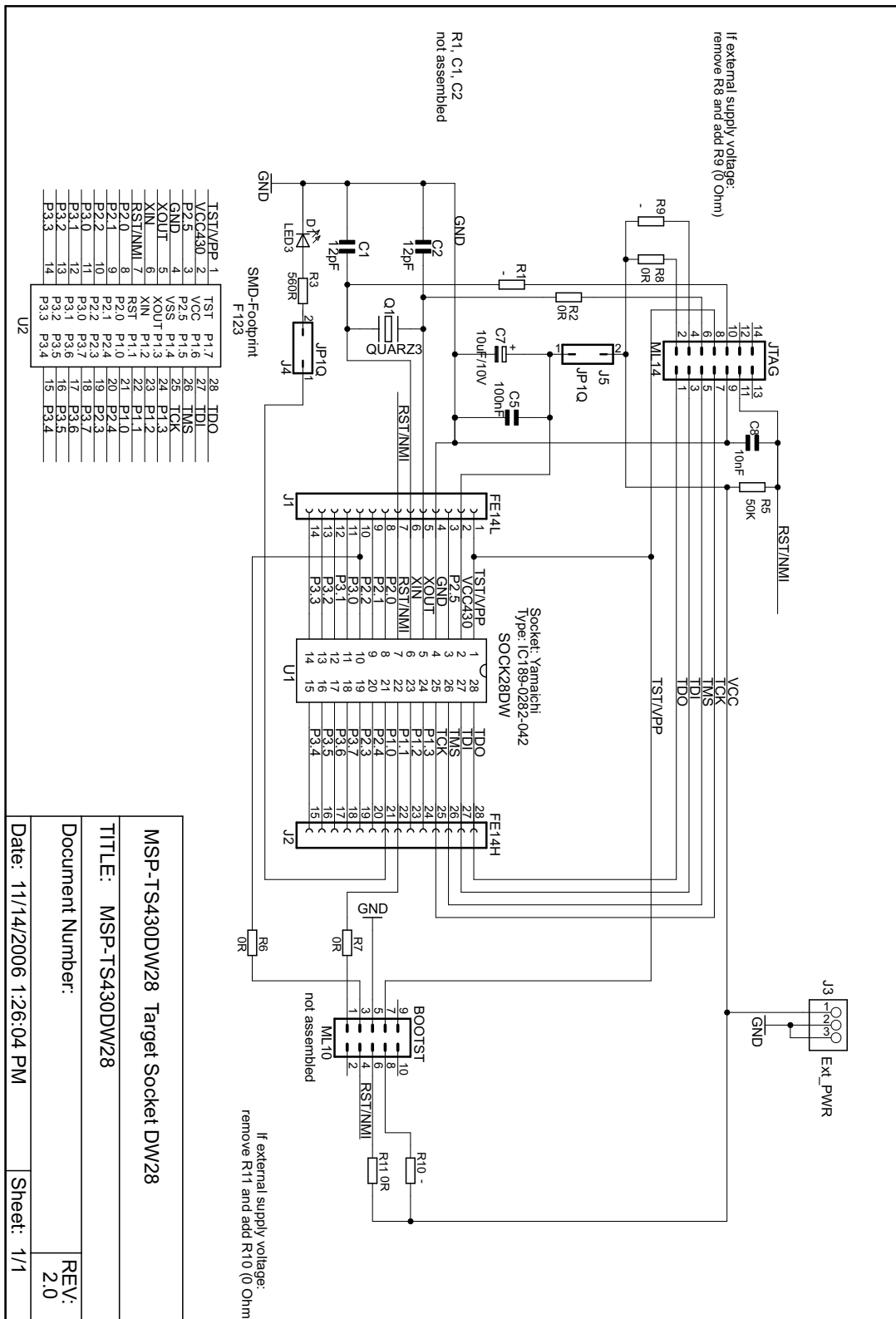

Figure B-16. MSP-TS430DW28 Target Socket Module, Schematic

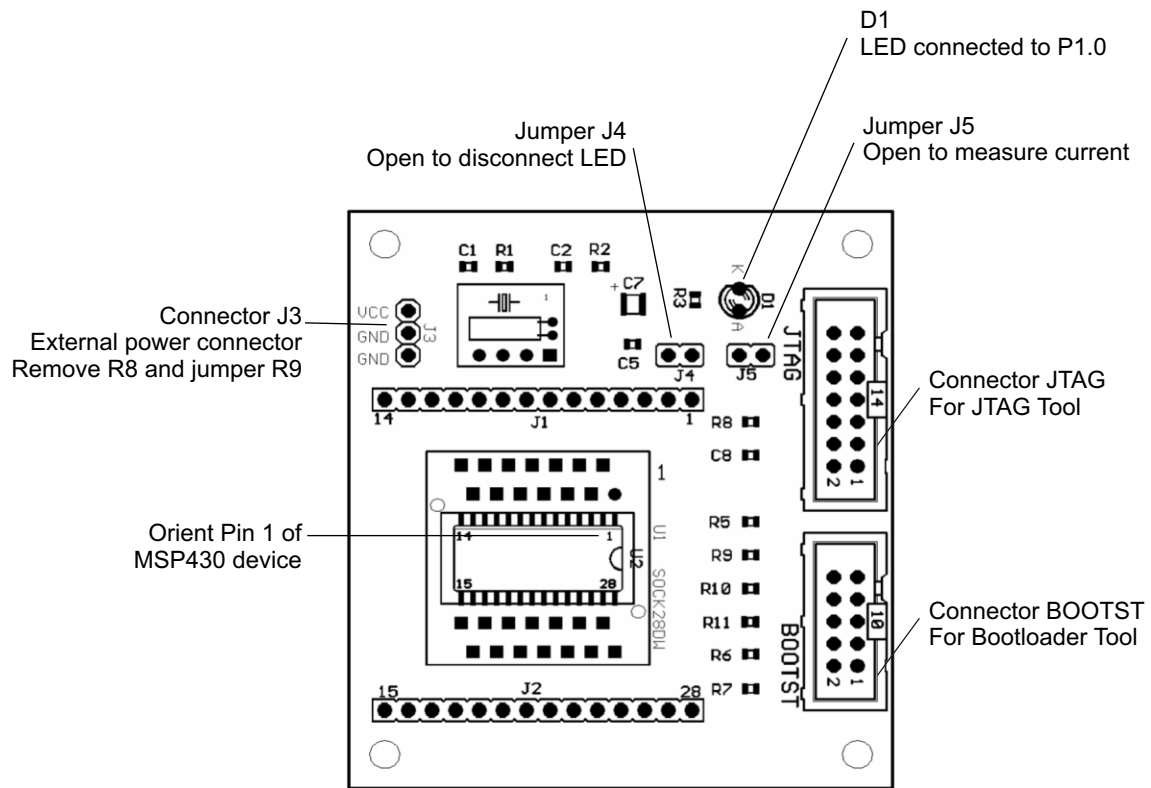

Figure B-17. MSP-TS430DW28 Target Socket Module, PCB

Table B-9. MSP-TS430DW28 Bill of Materials

Position	Ref Des	No. per Board	Description	Digi-Key Part No.	Comment
1	C1, C2	0	12pF, SMD0805		DNP: C1, C2, Cover holes while soldering
2	C5	1	100nF, SMD0805		
3	C7	1	10uF, 10V Tantal Elko B		
4	C8	1	10nF	SMD0805	
5	D1	1	LED3 T1 3mm yellow	RS: 228-4991	
6	Q1	0	QUARZ, Crystal	Micro Crystal MS1V-T1K 32.768kHz, C(Load) = 12.5pF	DNP: Cover holes while soldering
7	J1, J2	2	14-pin header, TH male		DNP: Headers and receptacles enclosed with kit. Keep vias free of solder. : Header : Receptacle
7.1		2	14-pin header, TH female		DNP: Headers and receptacles enclosed with kit. Keep vias free of solder. : Header : Receptacle
8	J3	1	3-Pin Connector, male		
9	J4, J5	2	2-Pin Connector, male		With jumper
10	BOOTST	0	ML10, 10-Pin Conn., m	RS: 482-115	DNP, Cover holes while soldering
11	JTAG	1	ML14, 14-Pin Conn., m	RS: 482-121	
12	R1, R2, R6, R7, R8,R9, R10, R11	4	0R, SMD0805		DNP: R1, R2, R9, R10
13	R3	1	560R, SMD0805		
14	R5	1	47K, SMD0805		
15	U1	1	SOP28DW socket	Yamaichi: IC189-0282-042	
16	U2	0	TSSOP		DNP

B.9 MSP-TS430PW28

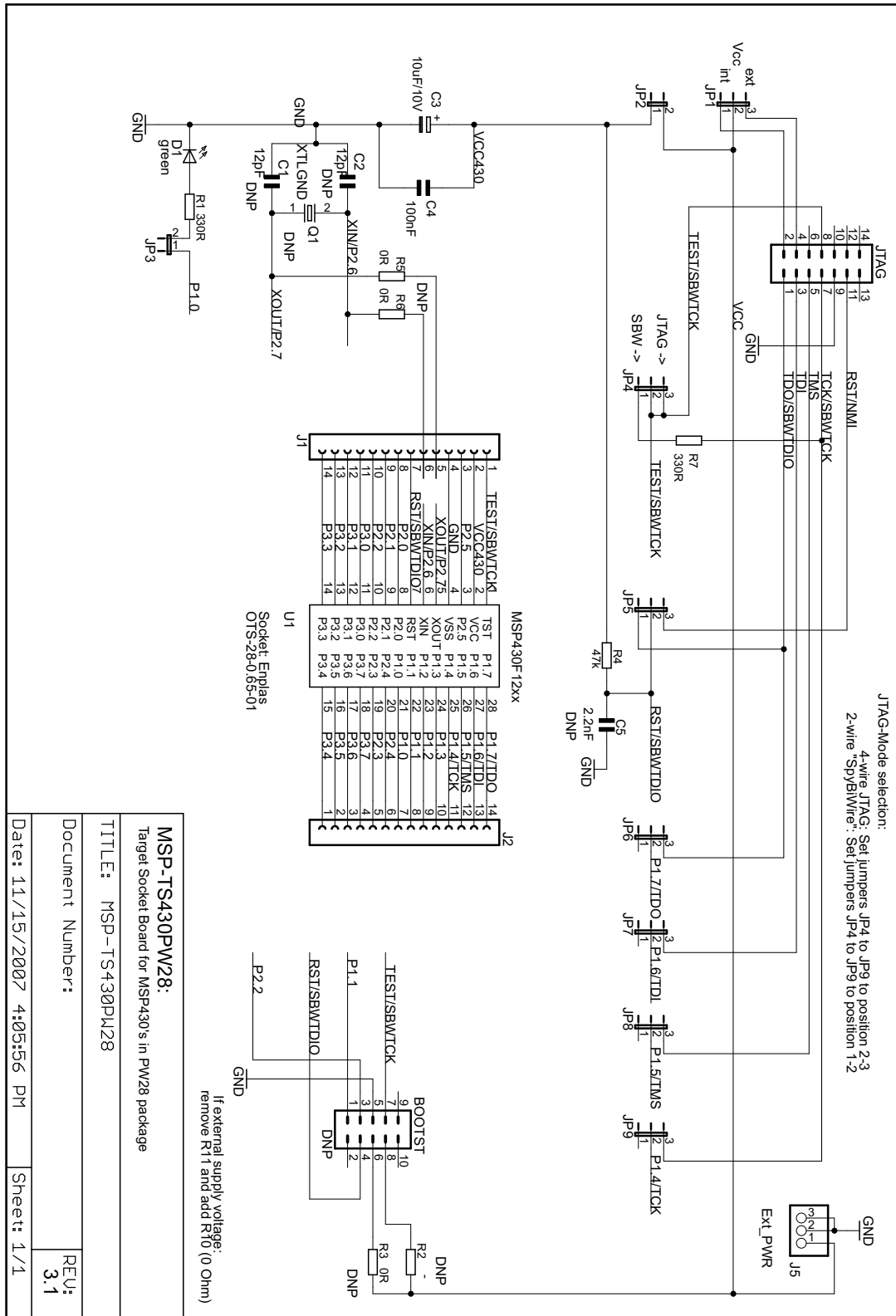

Figure B-18. MSP-TS430PW28 Target Socket Module, Schematic

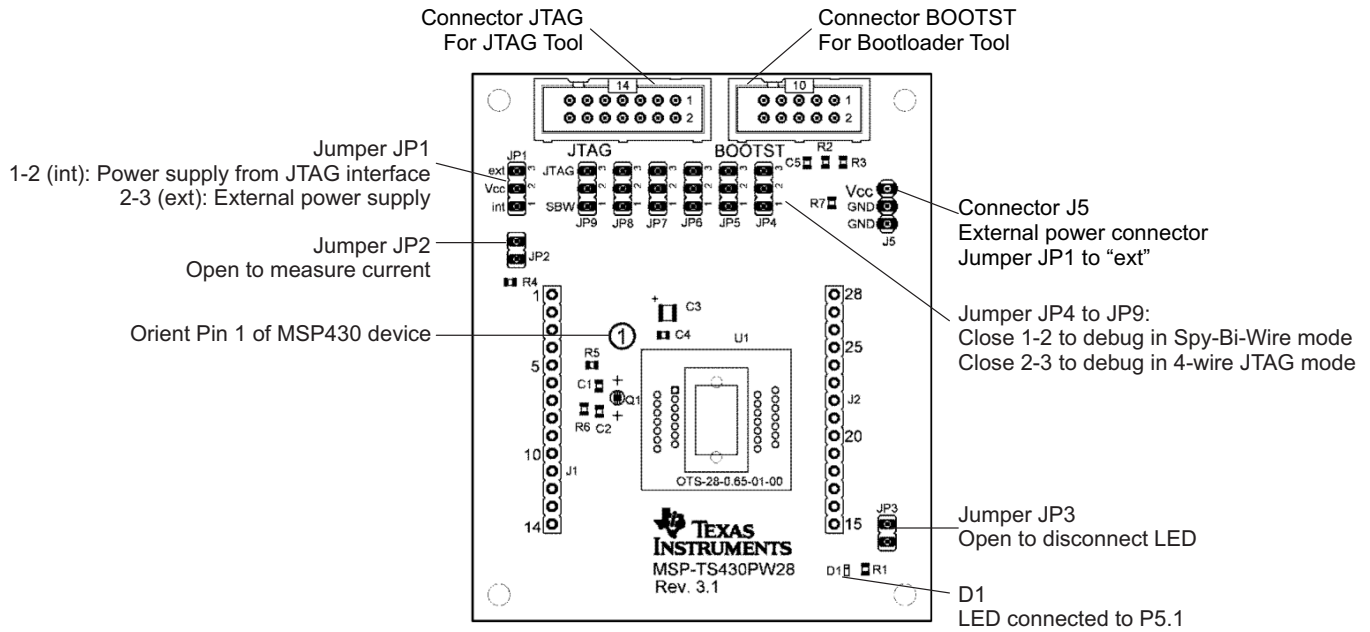

Figure B-19. MSP-TS430PW28 Target Socket Module, PCB

Table B-10. MSP-TS430PW28 Bill of Materials⁽¹⁾

Pos.	Ref Des	No. per Board	Description	Digi-Key Part No.	Comment
1	C1, C2	0	12pF, SMD0805		DNP: C1, C2 , Cover holes while soldering
2	C3	1	10uF, 10V Tantal Elko B		
3	C4	1	100nF, SMD0805		
4	C5	0	2.2nF, SMD0805		DNP
5	D1	1	LED green SMD0603		
6	Q1	0	QUARZ, Crystal	Micro Crystal MS1V-T1K 32.768kHz, C(Load) = 12.5pF	DNP: Cover holes and neighboring holes while soldering
7	J1, J2	2	14-pin header, TH male		DNP: Headers and receptacles enclosed with kit.Keep vias free of solder. : Header : Receptacle
7.1		2	14-pin header, TH female		DNP: headers and receptacles enclosed with kit.Keep vias free of solder. : Header : Receptacle
8	J5, IP1	1	3-Pin Connector , male		
8a	JP1, JP4, JP5, JP6, JP7, JP8, JP9	7	3-Pin Connector , male		Jumper on Pos 1-2
9	JP2, JP3	2	2-Pin Connector , male		with Jumper
10	BOOTST	0	ML10, 10-Pin Conn. , m	RS: 482-115	DNP: Cover holes while soldering
11	JTAG	1	ML14, 14-Pin Conn. , m	RS: 482-121	
12	R1, R7	2	330R, SMD0805		
12	R2, R3, R5, R6	0	0R, SMD0805		DNP
14	R4	1	47K, SMD0805		
15	U1	1	SOP28PW socket	Enplas: OTS-28-0.65-01	

⁽¹⁾ PCB 66 x 79 mm, two layers; Rubber stand off, four pieces

B.10 MSP-TS430PW28A

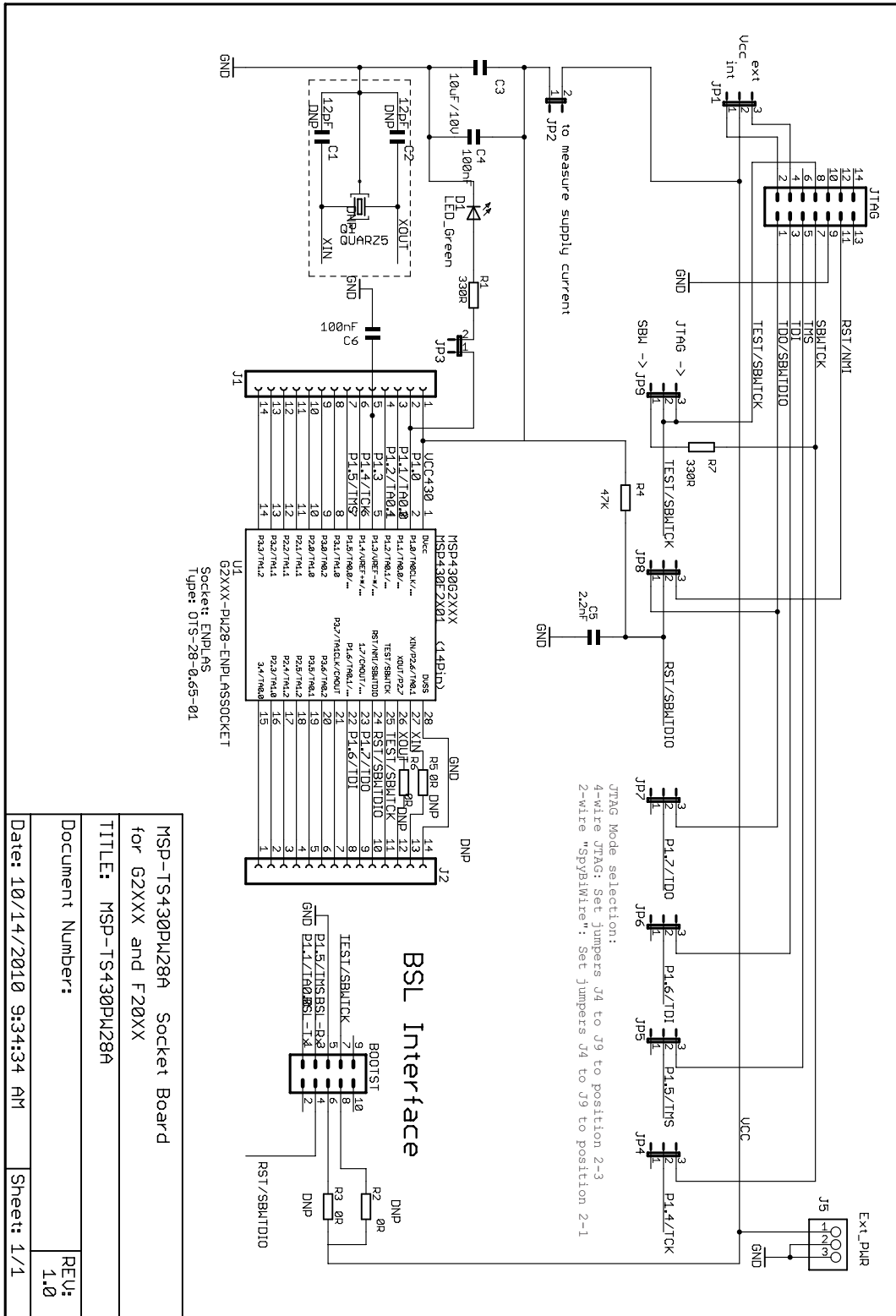

Figure B-20. MSP-TS430PW28A Target Socket Module, Schematic

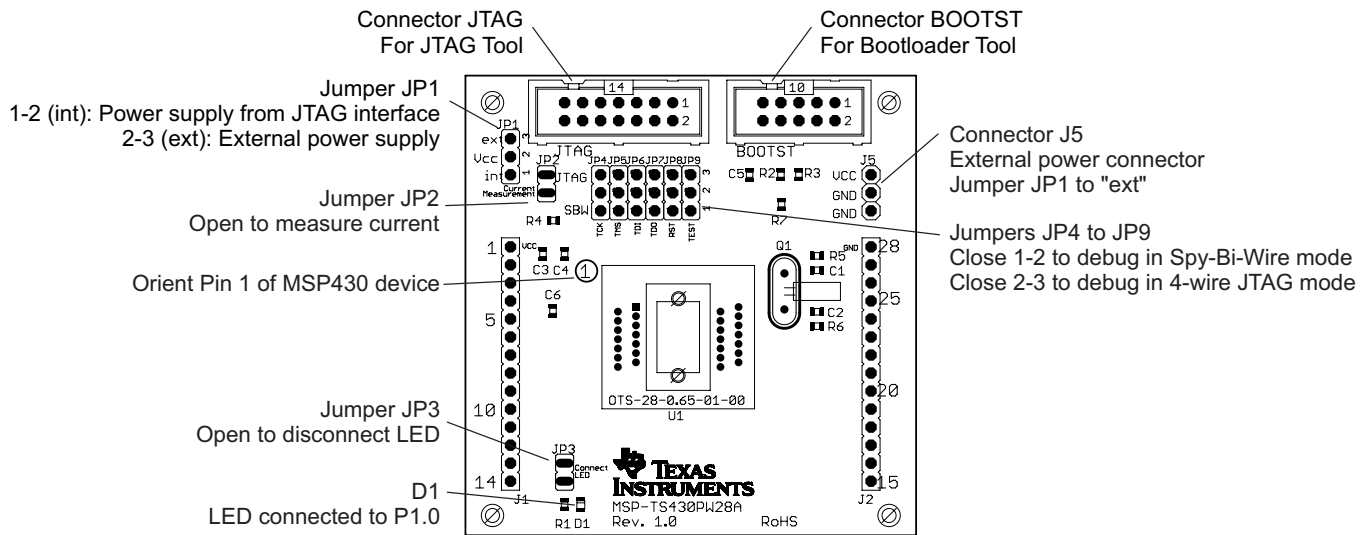

Figure B-21. MSP-TS430PW28A Target Socket Module, PCB (Red)

NOTE: For bootloader use, the BSL connector and only one of the resistors R2 or R3 need to be populated. If the board is supplied internally, R3 (0 Ω) must be assembled. If the board is supplied externally, R2 (0 Ω) must be assembled, and R3 must be removed.

Table B-11. MSP-TS430PW28A Bill of Materials

Position	Ref Des	No. per Board	Description	Digi-Key Part No.	Comment
1	C1, C2	0	12pF, SMD0805		DNP
2	C5	1	2.2nF, SMD0805		
3	C3	1	10uF, 10V, SMD0805		
4	C4, C6,	2	100nF, SMD0805	478-3351-2-ND	
5	D1	1	green LED, SMD0805	P516TR-ND	
6	J1, J2	0	14-pin header, TH		DNP: Headers and receptacles enclosed with kit. Keep vias free of solder: (Header and Receptacle)
7	J5, JP1, JP4, JP5, JP6, JP7, JP8, JP9	8	3-pin header, male, TH	SAM1035-03-ND	Place jumper on 1-2 of JP4-JP9 Place on 1-2 on JP1
8	JP2, JP3	2	2-pin header, male, TH	SAM1035-02-ND	Place jumper on header
9		9	Jumper	15-38-1024-ND	see Pos 7 an 8
10	JTAG	1	14-pin connector, male, TH	HRP14H-ND	
11	BOOTST	0			DNP Keep vias free of solder
12	Q1	0	Crystal	Micro Crystal MS3V 32.768kHz, C(Load) = 12.5pF	DNP: keep vias free of solder
13	R1, R7	2	330 Ω , SMD0805	541-330ATR-ND	
14	R2, R3,R5, R6,	0	0 Ohm, SMD0805	541-000ATR-ND	DNP R2, R3,R5, R6
15	R4	1	47k Ω , SMD0805	541-47000ATR-ND	
16	U1	1	Socket: OTS-28-0.65-01		Manuf.: Enplas
17	PCB	1	63.5 x 64.8 mm		2 layers
18	Adhesive plastic feet	4	Approximately 6mm width, 2mm height	for example, 3M Bumpons Part No. SJ-5302	Apply to corners at bottom side
19	MSP430	2	MSP430G2553IPW28		DNP: enclosed with kit, supplied by TI

B.11 MSP-TS430RHB32A

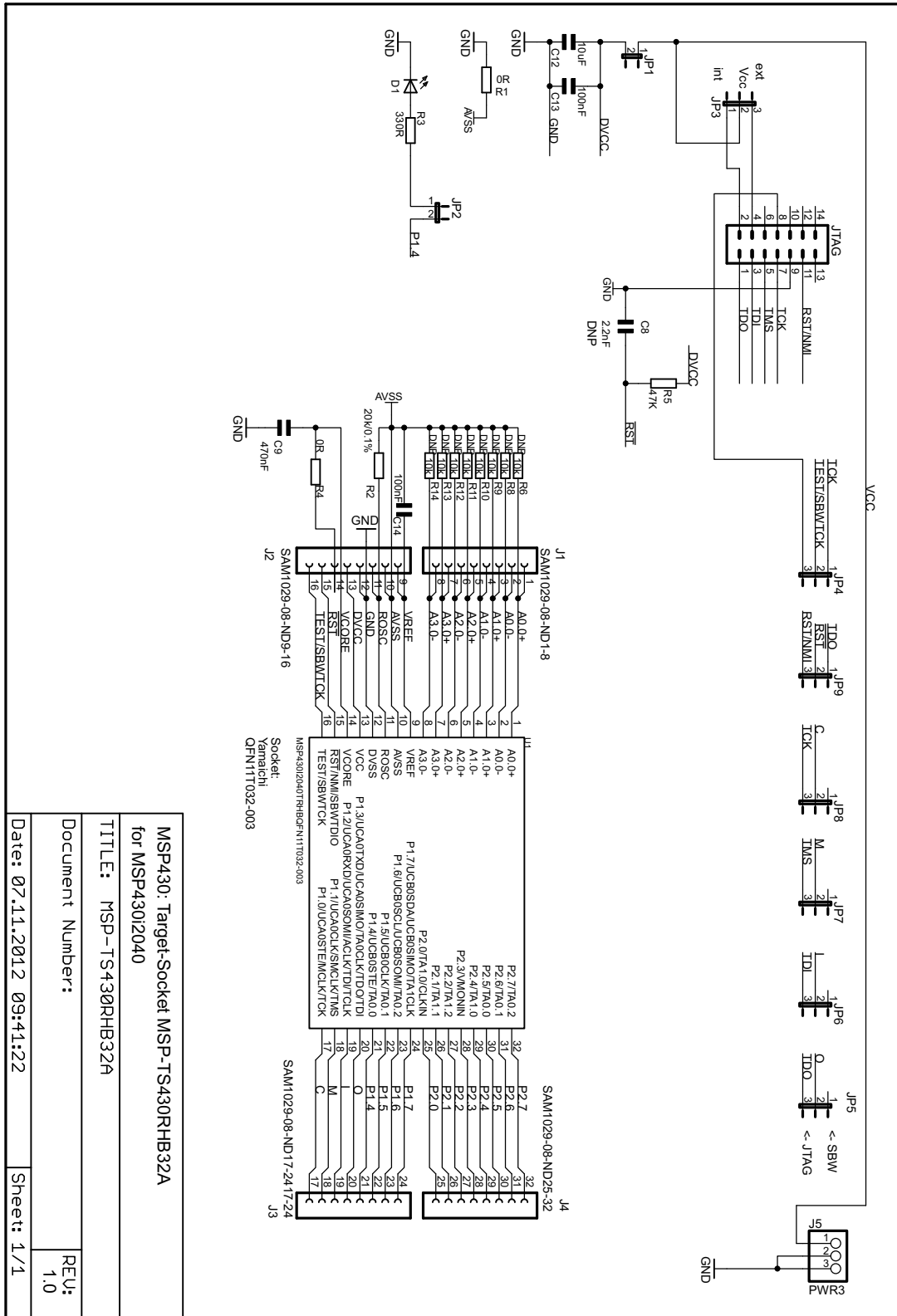

Figure B-22. MSP-TS430RHB32A Target Socket Module, Schematic

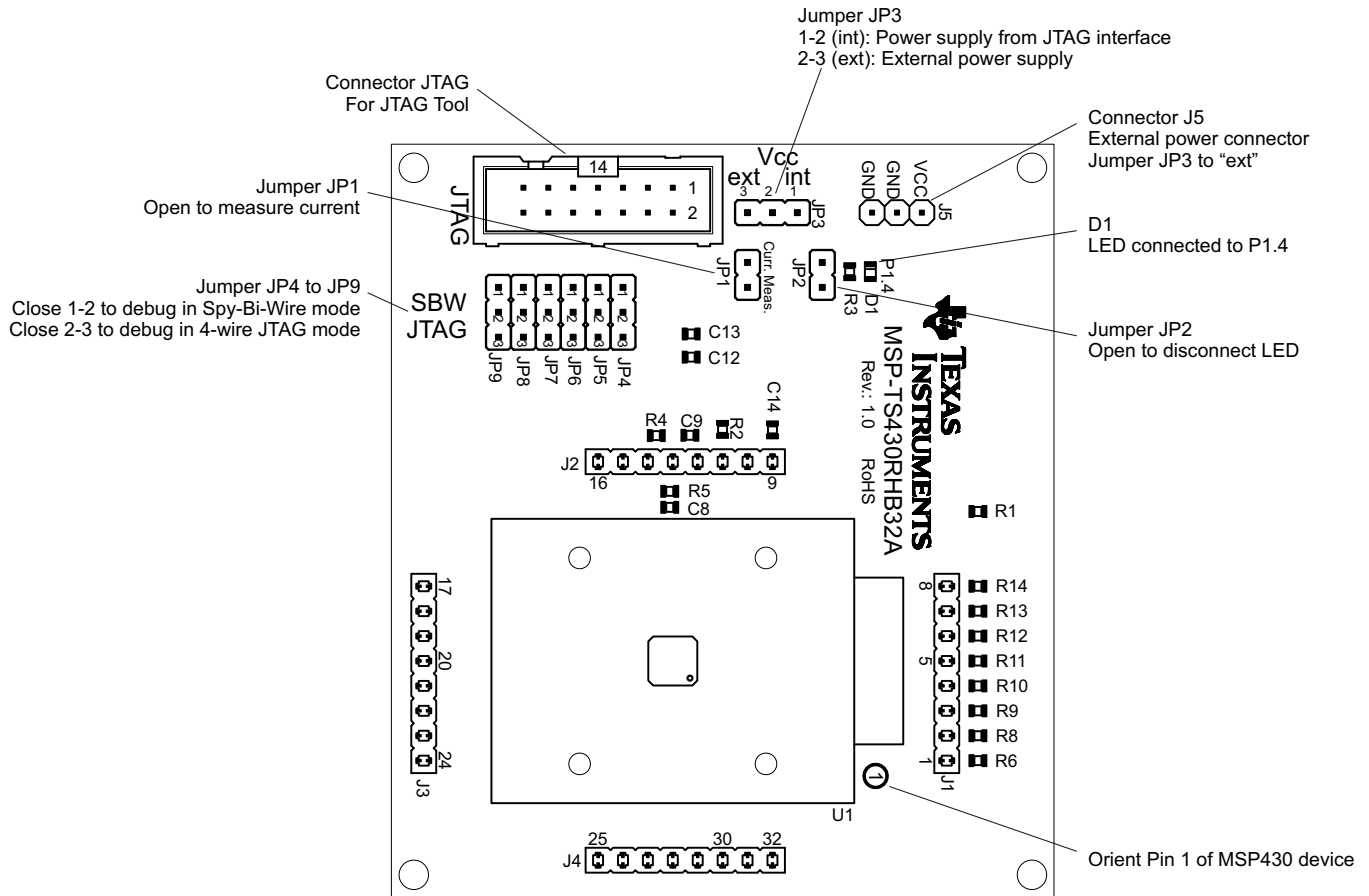

Figure B-23. MSP-TS430RHB32A Target Socket Module, PCB

Table B-12. MSP-TS430RHB32A Bill of Materials

Pos.	Ref Des	No. per Board	Description	Digi-Key Part No.	Comment
1	PCB	1	76.9 x 67.6 mm	MSP-TS430RHB32A Rev. 1	2 layers, red solder mask
2	D1	1	green LED, DIODE0805	P516TR-ND	
3	JP1, JP2	2	2-pin header, male, TH	SAM1035-02-ND	place jumper on header
4	JP3, JP4, JP5, JP6, JP7, JP8, JP9	7	3-pin header, male, TH	SAM1035-03-ND	place jumpers on pins 1-2 (SBW)
5	R1, R4	2	0R, 0805	541-0.0ATR-ND	
6	C8	1	2.2nF, CSMD0805	490-1628-2-ND	DNP
7	R6, R8, R9, R10, R11, R12, R13, R14	8	10k, 0805	311-10KARTR-ND	DNP
8	C12	1	10uF, CSMD0805	445-1371-2-ND	
9	R2	1	20k/0.1%, 0805	P20KDACT-ND	
10	R5	1	47K, 0805	311-47KARTR-ND	
11	C13, C14	2	100nF, CSMD0805	311-1245-2-ND	
12	R3	1	330R, 0805	541-330ATR-ND	
13	C9	1	470nF, CSMD0805	445-1357-2-ND	
14	J1, J2, J3, J4	1	8-pin header, TH	SAM1029-08-ND	DNP: headers and receptacles, enclosed with kit. Keep vias free of solder.
15	J1, J2, J3, J4	1	8-pin receptable, TH	SAM1213-08-ND	DNP: headers and receptacles, enclosed with kit. Keep vias free of solder.
16	JTAG	1	14-pin connector, male, TH	HRP14H-ND	
17	U1	1	Socket QFN11T032-003		Manuf.: Yamaichi
18	U1	1	MSP430i2041TRHB		DNP: enclosed with kit. Is supplied by TI
19	J5	1	3-pin header, male, TH	SAM1035-03-ND	
20	Rubber stand off	4		Buerklin: 20H1724	apply to corners at bottom side

B.12 MSP-TS430DA38

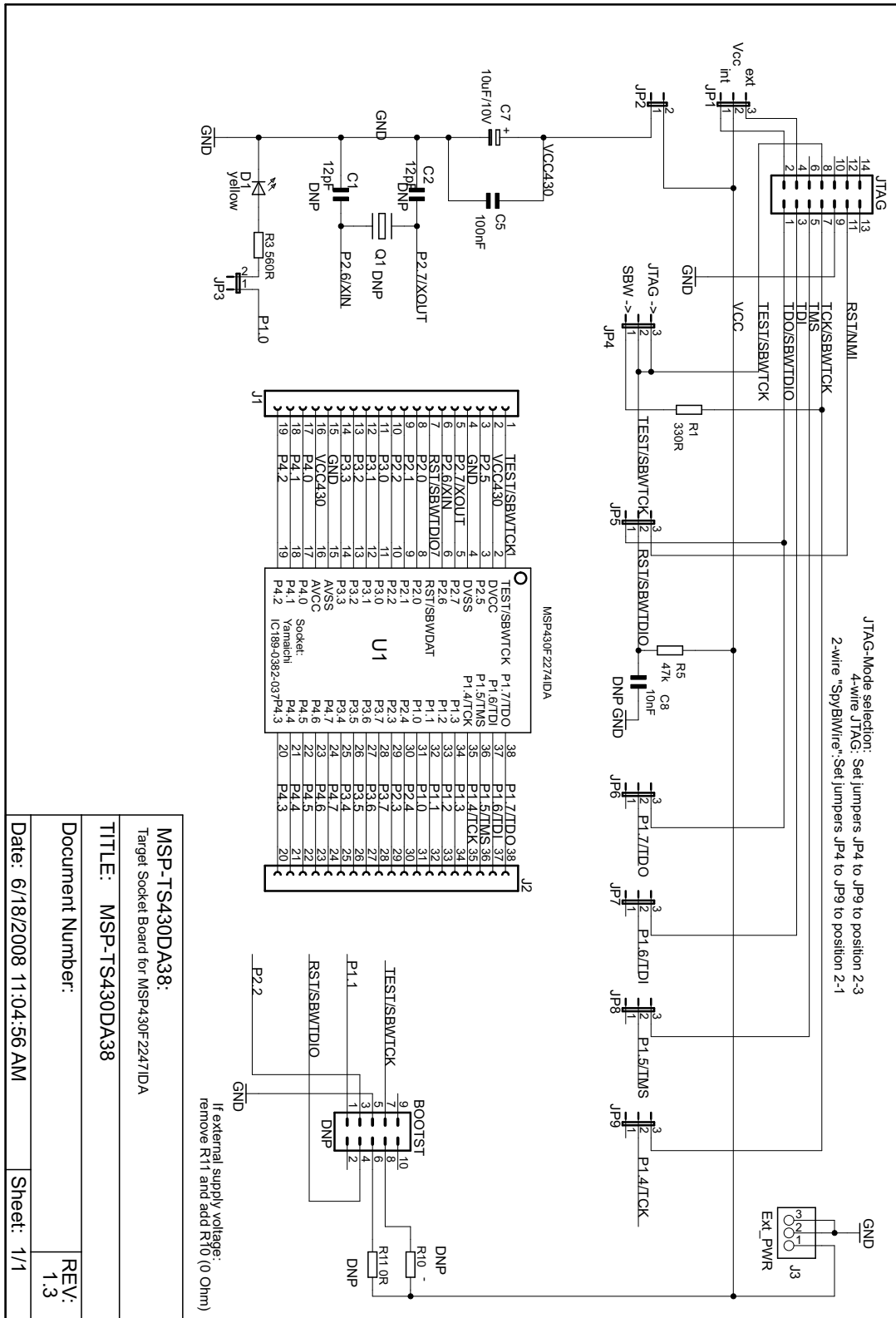

Figure B-24. MSP-TS430DA38 Target Socket Module, Schematic

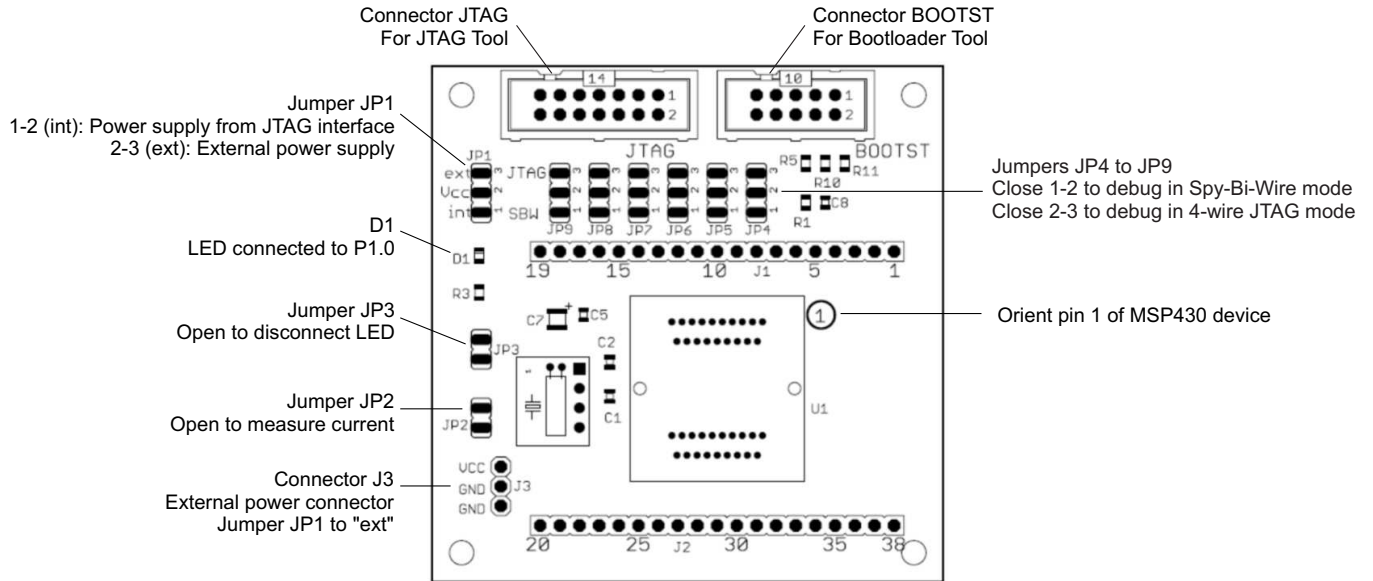

Figure B-25. MSP-TS430DA38 Target Socket Module, PCB

Table B-13. MSP-TS430DA38 Bill of Materials

Pos.	Ref Des	No. per Board	Description	Digi-Key Part No.	Comment
1	C1, C2	0	12pF, SMD0805		DNP
2	C7	1	10uF, 10V, Tantal Size B	511-1463-2-ND	
3	C5	1	100nF, SMD0805	478-3351-2-ND	
4	C8	0	2.2nF, SMD0805		DNP
5	D1	1	green LED, SMD0603	475-1056-2-ND	
6	J1, J2	0	19-pin header, TH	SAM1029-19-ND SAM1213-19-ND	DNP: headers and receptacles enclosed with kit. Keep vias free of solder. : Header : Receptacle
7	"J3, JP1, JP4, JP5, JP6, JP7, JP8, JP9"	8	3-pin header, male, TH	SAM1035-03-ND	Place jumpers on headers JP1, JP4, JP5, JP6, JP7, JP8, JP9; Pos 1-2
8	JP2, JP3	2	2-pin header, male, TH	SAM1035-02-ND	Place jumper on header
9		9	Jumper	15-38-1024-ND	Place on: JP1 - JP9; Pos 1-2
10	JTAG	1	14-pin connector, male, TH	HRP14H-ND	
11	BOOTST	0	10-pin connector, male, TH		DNP: Keep vias free of solder
12	Q1	0	Crystal	Micro Crystal MS1V-T1K 32.768kHz, C(Load) = 12.5pF	DNP: Keep vias free of solder
13	R1, R3	2	330 Ω , SMD0805	541-330ATR-ND	
14	R10, R11	0	0 Ω , SMD0805	541-000ATR-ND	DNP
15	R5	1	47k Ω , SMD0805	541-47000ATR-ND	
16	U1	1	Socket: IC189-0382--037		Manuf.: Yamaichi
17	PCB	1	67 x 66 mm		2 layers
18	Adhesive Plastic feet	4	~6mm width, 2mm height	for example, 3M Bumpons Part No. SJ-5302	Apply to corners at bottom side
19	MSP430	2	MSP430F2274IDA		DNP: enclosed with kit supplied by TI

B.13 MSP-TS430QFN23x0

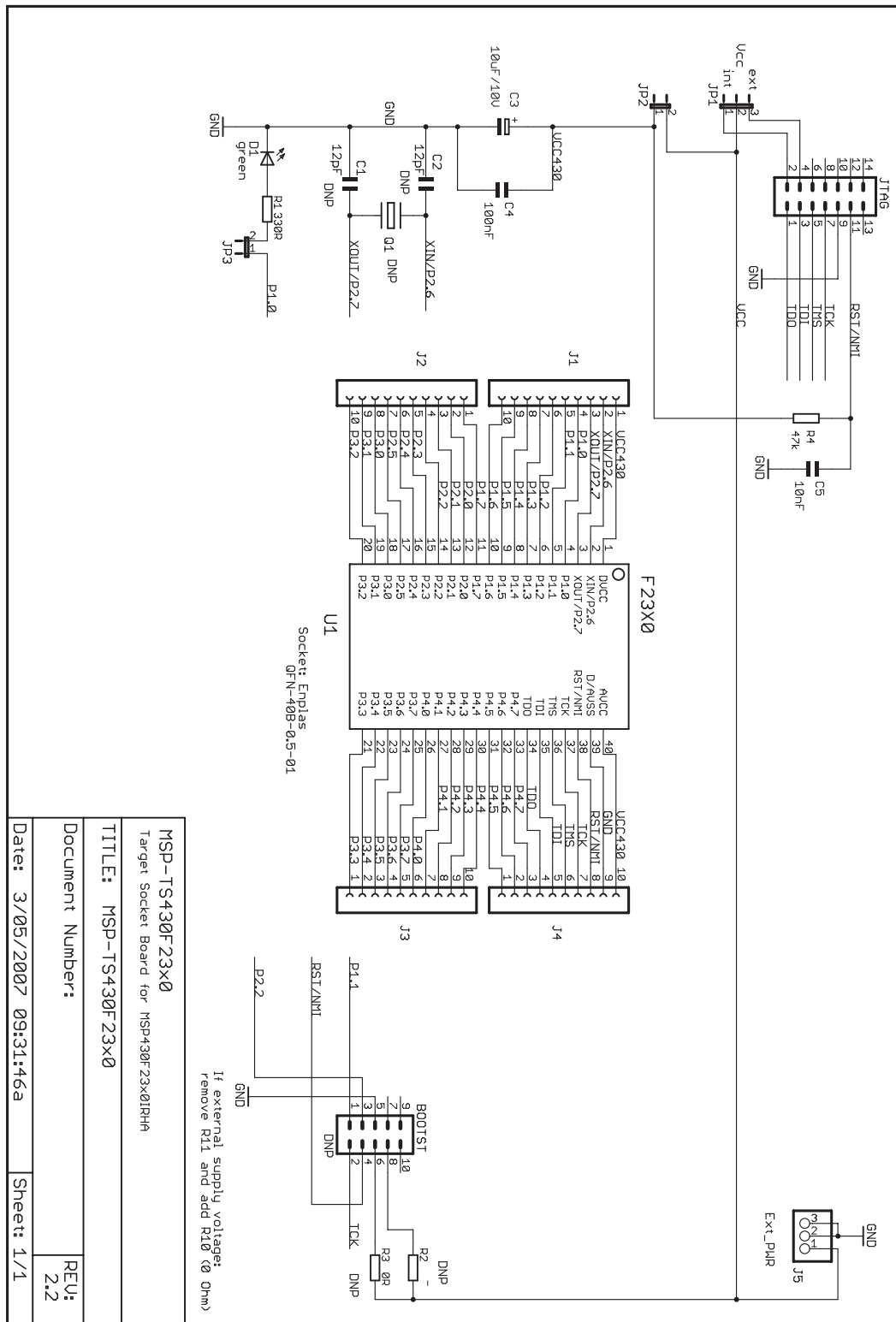

Figure B-26. MSP-TS430QFN23x0 Target Socket Module, Schematic

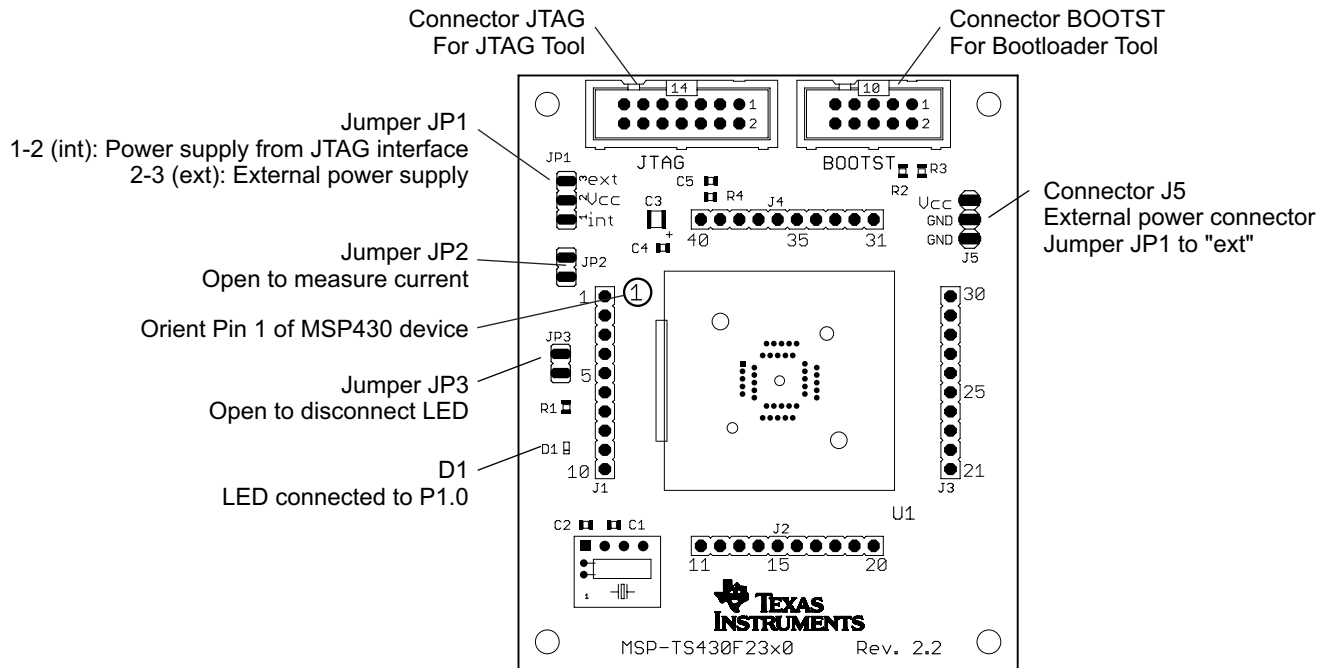

Figure B-27. MSP-TS430QFN23x0 Target Socket Module, PCB

NOTE: For bootloader use, the BSL connector and only one of the resistors R2 or R3 need to be populated. If the board is supplied internally, R3 (0 Ω) must be assembled. If the board is supplied externally, R2 (0 Ω) must be assembled, and R3 must be removed.

Table B-14. MSP-TS430QFN23x0 Bill of Materials

Pos.	Ref Des	No. per Board	Description	Digi-Key Part No.	Comment
1	C1, C2	0	12pF, SMD0805		DNP
2	C3	1	10uF, 10V, Tantal Size B	511-1463-2-ND	
3	C4	1	100nF, SMD0805	478-3351-2-ND	
4	C5	1	10nF, SMD0805	478-1383-2-ND	
5	D1	1	green LED, SMD0603	475-1056-2-ND	
6	J1, J2, J3, J4	0	10-pin header, TH	SAM1034-10-ND SAM1212-10-ND	DNP: headers and receptacles enclosed with kit. Keep vias free of solder. : Header : Receptacle
7	J5, JP1	2	3-pin header, male, TH	SAM1035-03-ND	Place jumper on header JP1; Pos 1-2.
8	JP2, JP3	2	2-pin header, male, TH	SAM1035-02-ND	Place jumper on header
9		3	Jumper	15-38-1024-ND	Place on: JP1, JP2, JP3
10	JTAG	1	14-pin connector, male, TH	HRP14H-ND	
11	BOOTST	0	10-pin connector, male, TH		DNP: Keep vias free of solder
12	Q1	0	Crystal	Micro Crystal MS1V-T1K 32.768kHz, C(Load) = 12.5pF	DNP: Keep vias free of solder
13	R1	1	330 Ω , SMD0805	541-330ATR-ND	
14	R2, R3	0	0 Ω , SMD0805	541-000ATR-ND	DNP
15	R4	1	47k Ω , SMD0805	541-47000ATR-ND	
16	U1	1	Socket: QFN-40B-0.5-01		Manuf.: Enplas
17	PCB	1	79 x 66 mm		2 layers
18	Adhesive Plastic feet	4	~6mm width, 2mm height	for example, 3M Bumpons Part No. SJ-5302	Apply to corners at bottom side
19	MSP430	2	MSP430F2370IRHA		DNP: enclosed with kit supplied by TI

B.14 MSP-TS430RSB40

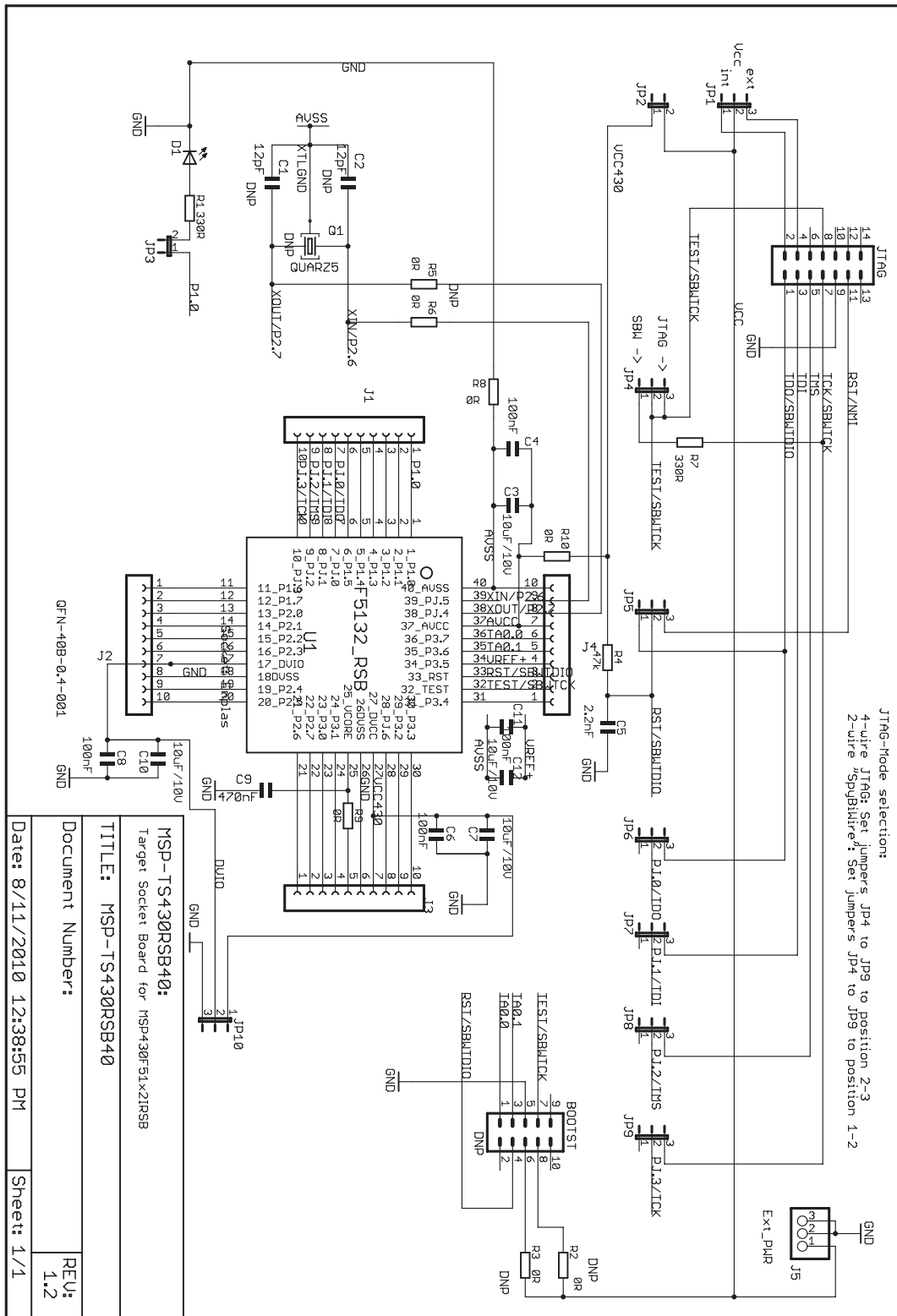

Figure B-28. MSP-TS430RSB40 Target Socket Module, Schematic

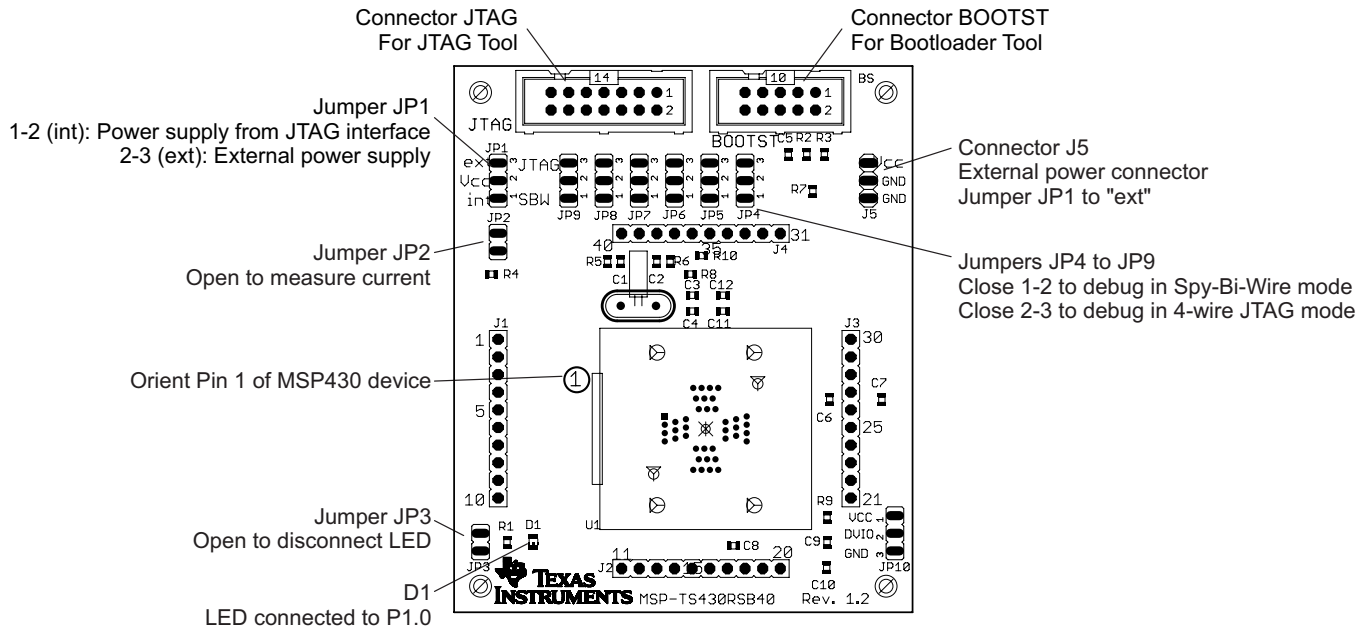

Figure B-29. MSP-TS430RSB40 Target Socket Module, PCB

NOTE: For bootloader use, the BSL connector and only one of the resistors R2 or R3 need to be populated. If the board is supplied internally, R3 (0 Ω) must be assembled. If the board is supplied externally, R2 (0 Ω) must be assembled, and R3 must be removed.

Table B-15. MSP-TS430RSB40 Bill of Materials

Pos.	Ref Des	No. Per Board	Description	Digi-Key Part No.	Comment
1	C1, C2	0	12pF, SMD0805		DNP: C1, C2
2	C3, C7, C10, C12	3	10uF, 10V, SMD 0805	445-1371-1-ND	DNP C12
3	C4, C6, C8, C11	3	100nF, SMD0805	311-1245-2-ND	DNP C11
4	C5	1	2.2nF, SMD0805		
5	C9	1	470nF, SMD0805		
6	D1	1	green LED, SMD0805	P516TR-ND	
7	J1, J2, J3, J4	4	10-pin header, TH		DNP: headers and receptacles enclosed with kit. Keep vias free of solder. : Header : Receptacle
7.1		4	10-pin header, TH		DNP: headers and receptacles enclosed with kit. Keep vias free of solder. : Header : Receptacle
8	JP1, JP4, JP5, JP6, JP7, JP8, JP9, J5, JP10	9	3-pin header, male, TH	SAM1035-03-ND	Jumper: 1-2 on JP1, JP10; 2-3 on JP4-JP9
9	JP2, JP3	2	2-pin header, male, TH	SAM1035-02-ND	place jumper on header
10	JTAG	1	14-pin connector, male, TH	HRP14H-ND	
11	BOOTST	0	10-pin connector, male, TH		DNP. Keep vias free of solder
12	U1	1	QFN-40B-0.4_ENPLAS_SOCKET	Enplas	
13	Q1	0	Crystal	Micro Crystal MS3V-T1R 32.768kHz, C(Load) = 12.5pF	DNP: Q1. Keep vias free of solder
15		10	Jumper	15-38-1024-ND	Place on: JP1, JP2, JP3, JP4, JP5, JP6, JP7, JP8, JP9, JP10
16	R1, R7	2	330R SMD0805		
17	R2, R3, R5, R6, R8, R9, R10	3	0R SMD0805		DNP R2, R3, R5, R6
18	R4	1	47k SMD0805		
19	MSP430	2	MSP430F5132		DNP: enclosed with kit. Is supplied by TI
20	Rubber stand off	4		select appropriate; for example, Buerklin: 20H1724	apply to corners at bottom side

B.15 MSP-TS430RHA40A

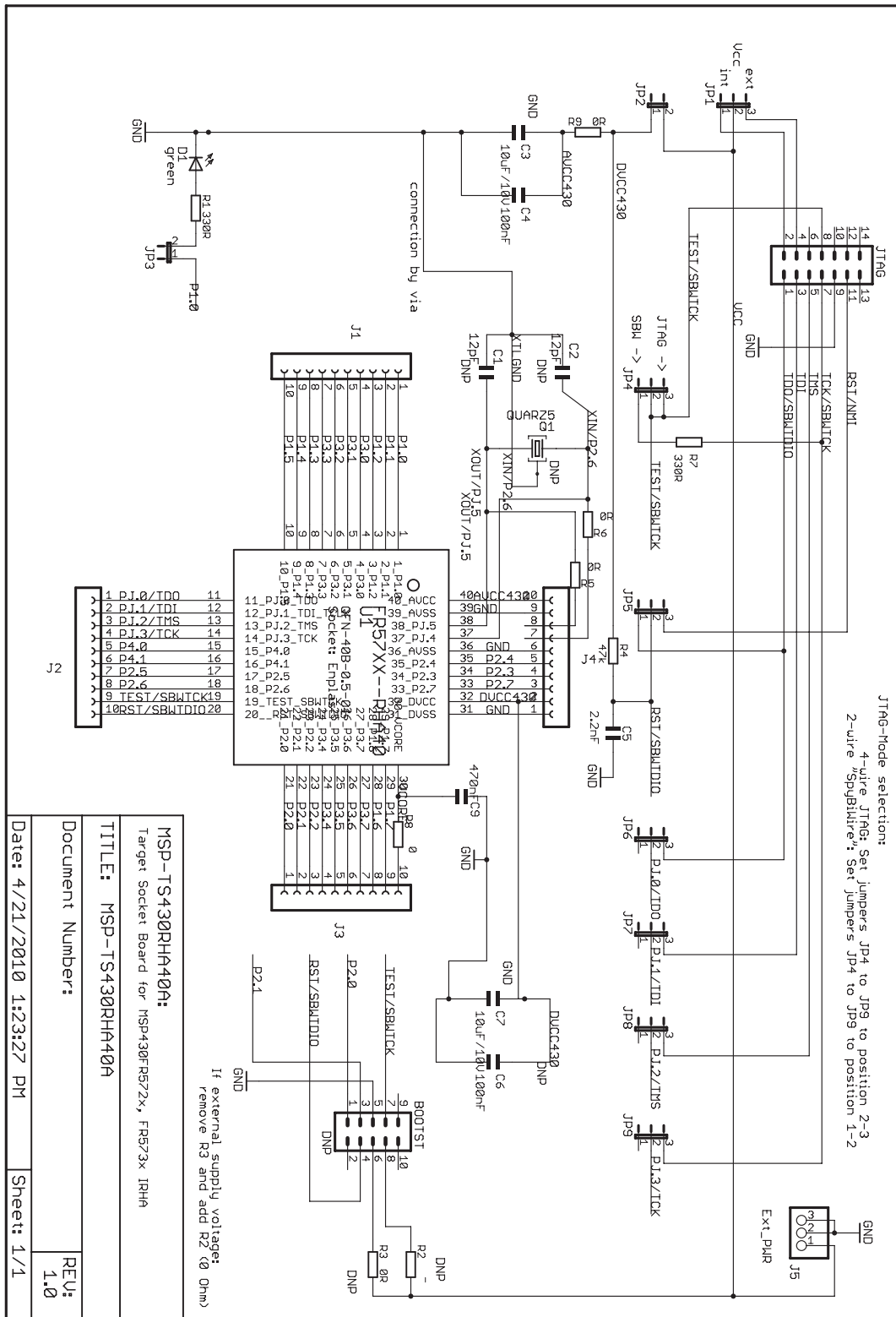

Figure B-30. MSP-TS430RHA40A Target Socket Module, Schematic

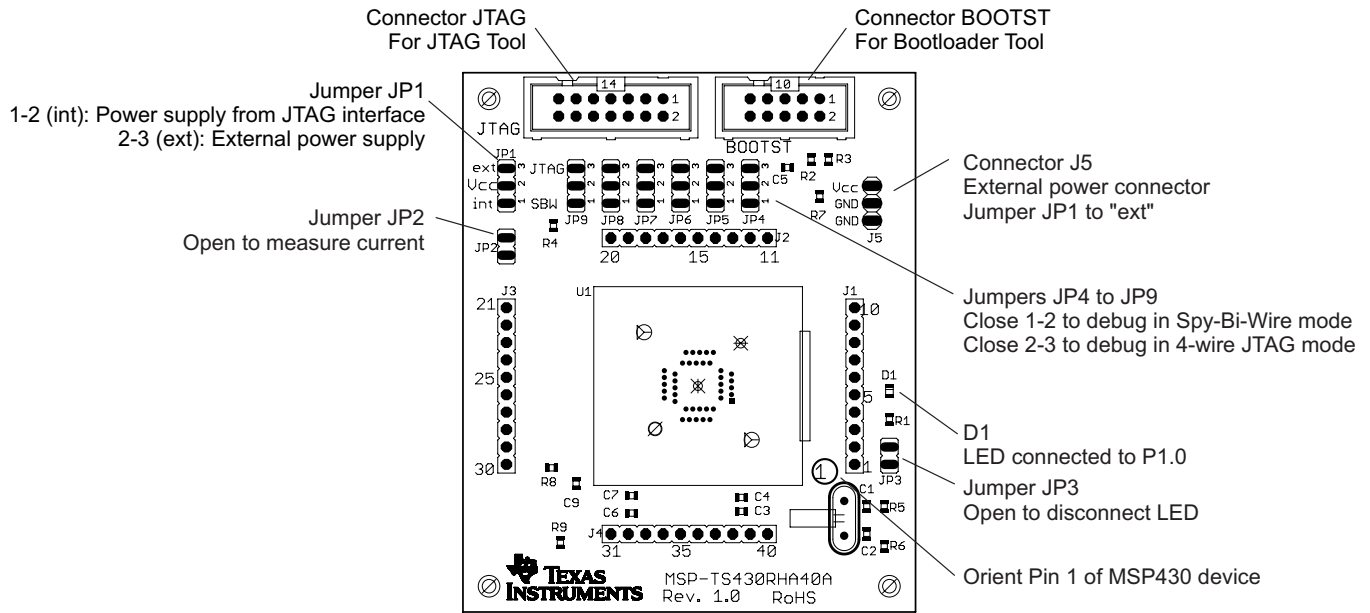

Figure B-31. MSP-TS430RHA40A Target Socket Module, PCB

Table B-16. MSP-TS430RHA40A Bill of Materials

Position	Ref Des	No. per Board	Description	Digi-Key Part No.	Comment
1	C1, C2	0	12pF, SMD0805		DNP: C1, C2
2	C5	0	2.2nF, SMD0805		DNP C12
3	C3, C7	2	10uF, 10V, SMD0805 5		DNP C11
4	C4, C6	2	100nF, SMD0805	478-3351-2-ND	
5	C9	1	470nF, SMD0805		
6	D1	1	green LED, SMD0805	P516TR-ND	
7	J1, J2, J3, J4	4	10-pin header, TH		DNP: headers and receptacles enclosed with kit. Keep vias free of solder. : Header : Receptacle
7.1		4	10-pin header, TH		DNP: headers and receptacles enclosed with kit. Keep vias free of solder. : Header : Receptacle
8	J5, JP1, JP4, JP5, JP6, JP7, JP8, JP9	8	3-pin header, male, TH	SAM1035-03-ND	Place jumper on 1-2 of JP4-JP9; Place on 1-2 on JP1
9	JP2, JP3	2	2-pin header, male, TH	SAM1035-02-ND	place jumper on header
10		9	Jumper	15-38-1024-ND	see Pos 8 an 9
11	JTAG	1	14-pin connector, male, TH	HRP14H-ND	
12	BOOTST	0	10-pin connector, male, TH		DNP. Keep vias free of solder
13	U1	1	Socket: QFN-40B-0.5-01		Manuf.: Enplas
14	Q1	0	Crystal	Micro Crystal MS3V-T1R 32.768kHz, C(Load) = 12.5pF	DNP: Q1. Keep vias free of solder
15	R1,R7	2	330R SMD0805	541-330ATR-ND	
16	R2, R3, R5, R6, R8, R9,	2	0 Ohm, SMD0805	541-000ATR-ND	DNP:R2, R3, R5, R6
17	R4	1	47k SMD0805		
18	PCB	1	79 x 66 mm		2 layers
19	Rubber stand off	4		select appropriate; for example, Buerklin: 20H1724	apply to corners at bottom side
20	MSP430	2	MSP430N5736IRHA		DNP: enclosed with kit. Is supplied by TI

B.16 MSP-TS430DL48

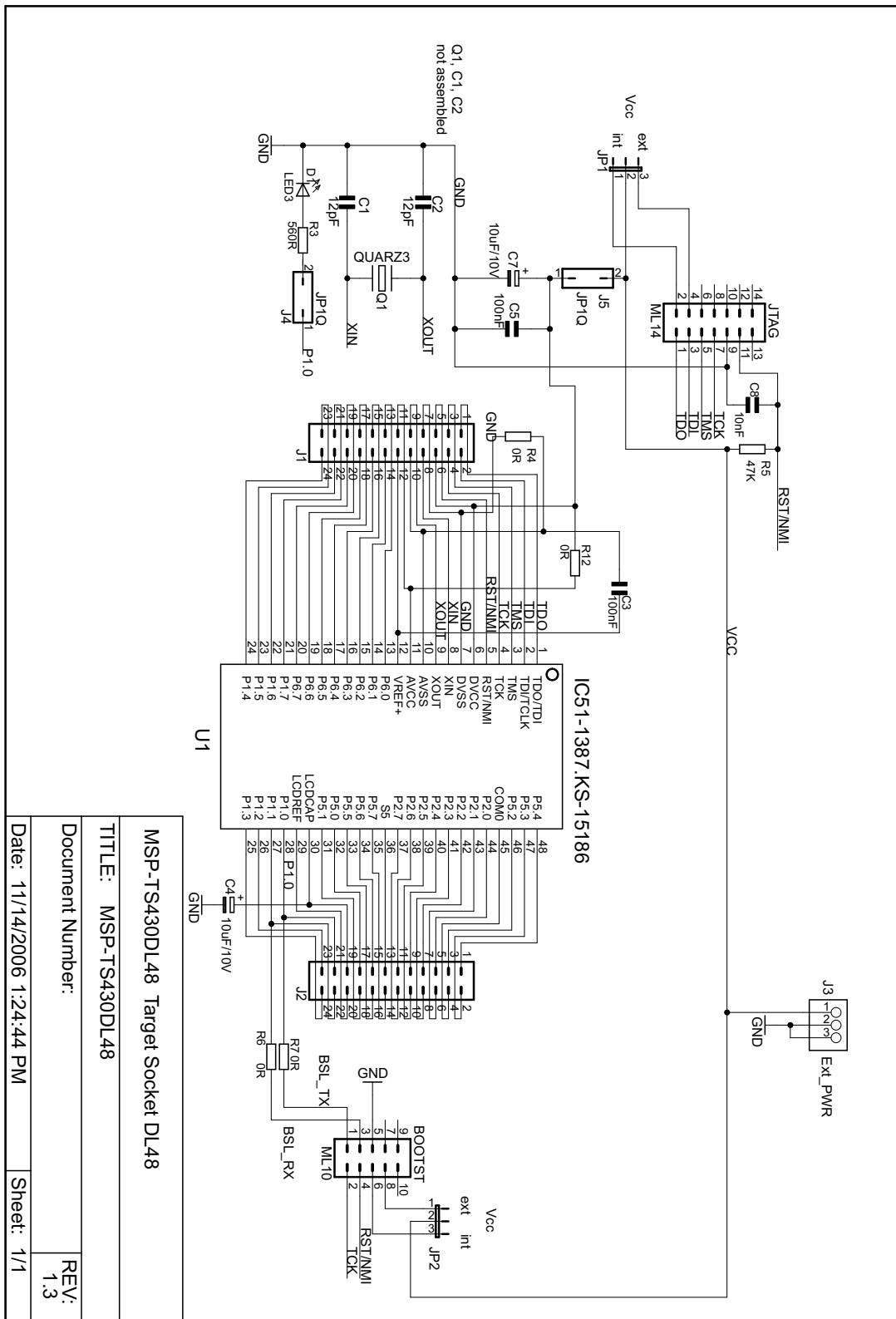

Figure B-32. MSP-TS430DL48 Target Socket Module, Schematic

MSP-TS430DL48 Target Socket DL48	
TITLE: MSP-TS430DL48	
Document Number:	
Date: 11/14/2006 1:24:44 PM	Sheet: 1/1
REV:	1.3

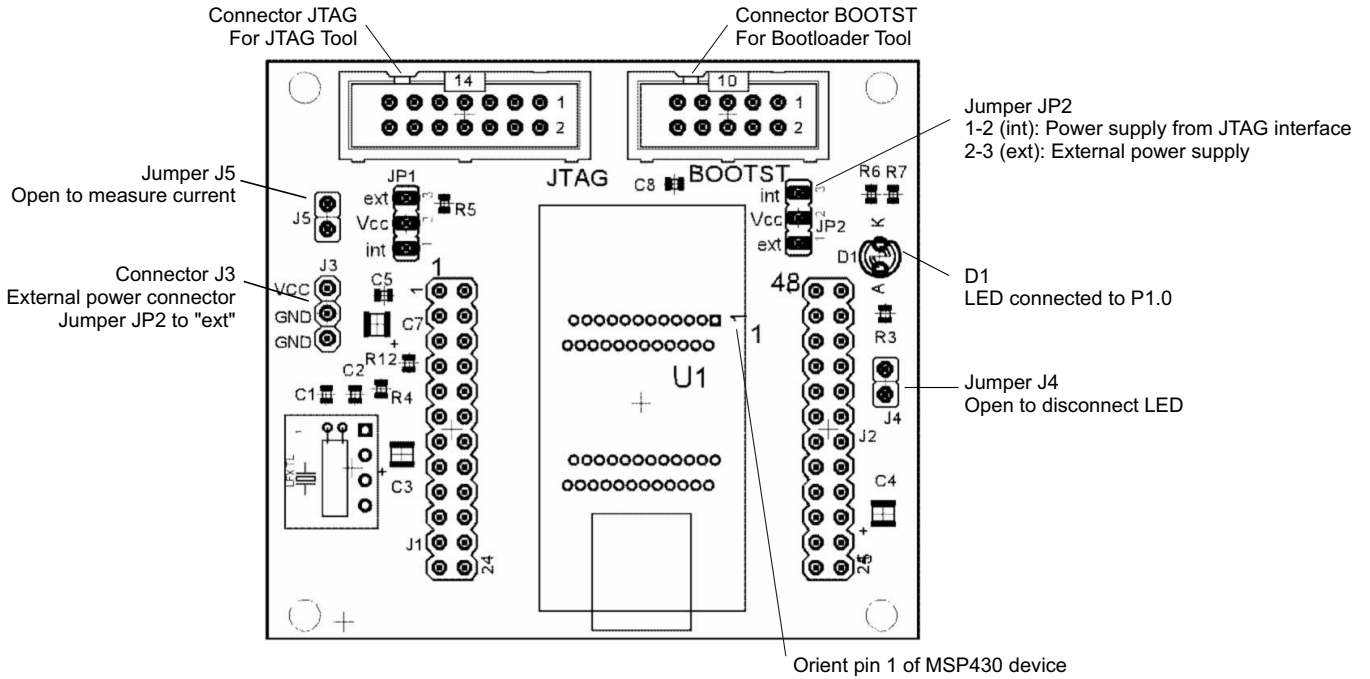

Figure B-33. MSP-TS430DL48 Target Socket Module, PCB

Table B-17. MSP-TS430DL48 Bill of Materials

Pos.	Ref Des	No. per Board	Description	Digi-Key Part No.	Comment
1	C1, C2	0	12pF, SMD0805		DNP
2	C4, C7	2	10uF, 10V, Tantal Size B	511-1463-2-ND	
3	C3, C5	2	100nF, SMD0805	478-3351-2-ND	
4	C8	1	10nF, SMD0805	478-1383-2-ND	
5	D1	1	yellow LED, TH, 3mm, T1	511-1251-ND	
6	J1, J2	0	24-pin header, TH	SAM1034-12-ND SAM1212-12-ND	DNP: Headers and receptacles enclosed with kit. Keep vias free of solder. : Header : Receptacle
7	J3, JP1, JP2	2	3-pin header, male, TH	SAM1035-03-ND	Place jumper on header JP1; Pos 1-2. DNP: JP2
8	J4, J5	2	2-pin header, male, TH	SAM1035-02-ND	Place jumper on header
9		3	Jumper	15-38-1024-ND	Place on: JP1, J4, J5
10	JTAG	1	14-pin connector, male, TH	HRP14H-ND	
11	BOOTST	0	10-pin connector, male, TH		DNP: Keep vias free of solder
12	Q1	0	Crystal	Micro Crystal MS1V-T1K 32.768kHz, C(Load) = 12.5pF	DNP: Keep vias free of solder
13	R3	1	560 Ω , SMD0805	541-560ATR-ND	
14	R4, R6, R7, R12	2	0 Ω , SMD0805	541-000ATR-ND	DNP: R6, R7
15	R5	1	47k Ω , SMD0805	541-47000ATR-ND	
16	U1	1	Socket: IC51-1387 KS-15186		Manuf.: Yamaichi
17	PCB	1	58 x 66 mm		2 layers
18	Adhesive Plastic feet	4	~6mm width, 2mm height	for example, 3M Bumpons Part No. SJ-5302	Apply to corners at bottom side
19	MSP430	2	MSP430F4270IDL		DNP: Enclosed with kit supplied by TI

B.17 MSP-TS430RGZ48B

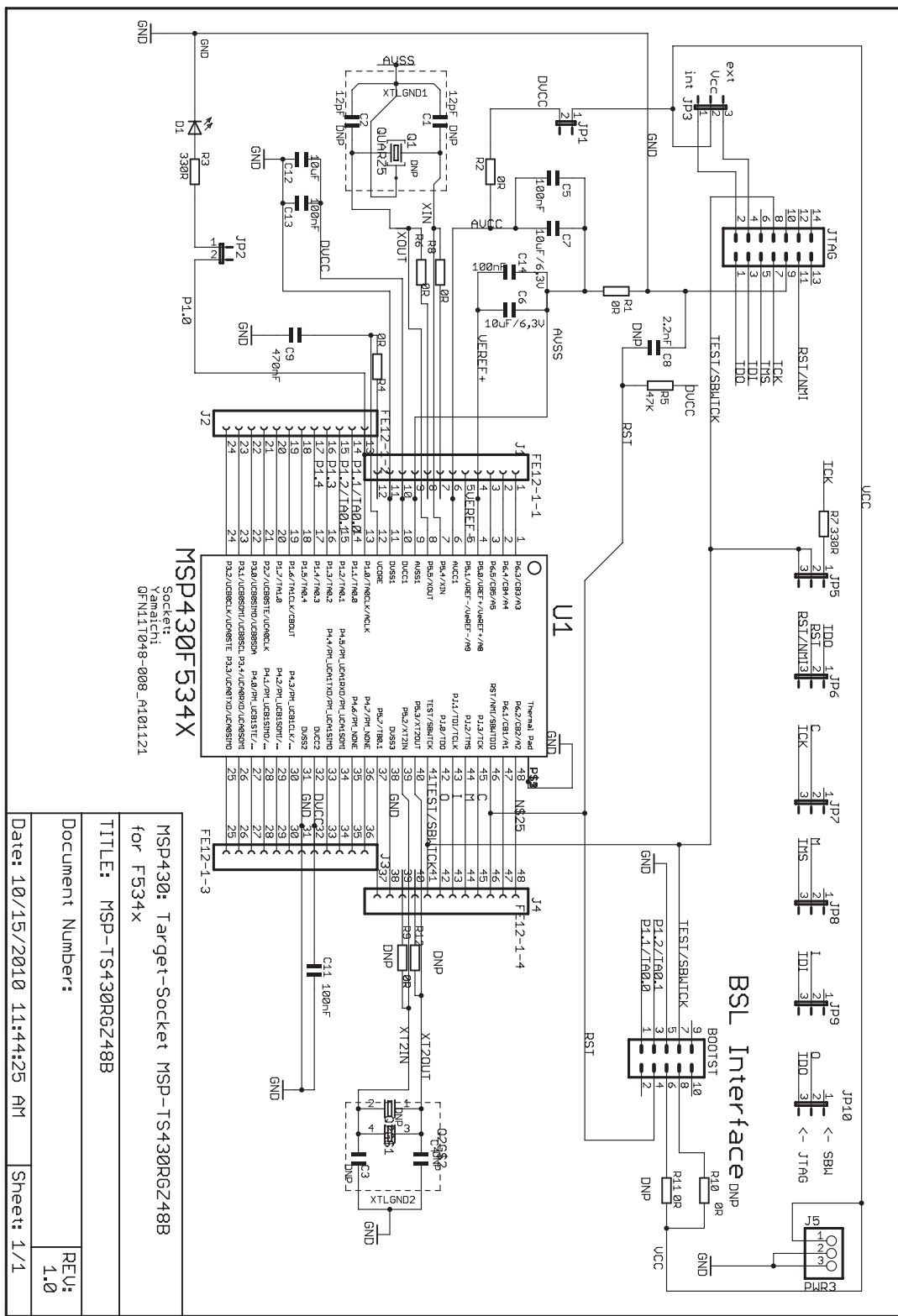

Figure B-34. MSP-TS430RGZ48B Target Socket Module, Schematic

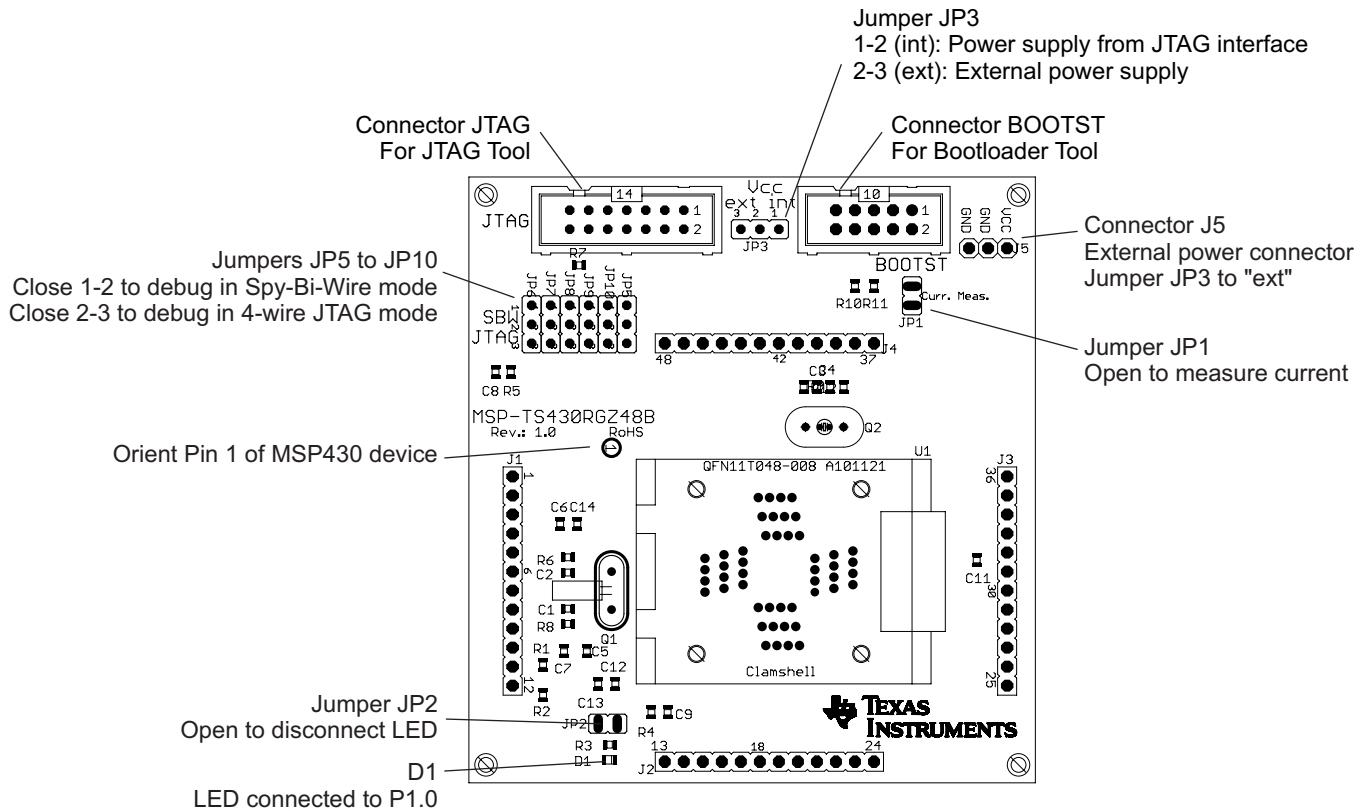

Figure B-35. MSP-TS430RGZ48B Target Socket Module, PCB

NOTE: For bootloader use, the BSL connector and only one of the resistors R10 or R11 must be populated. If the board is supplied internally, R11 (0 Ω) must be assembled. If the board is supplied externally, R10 (0 Ω) must be assembled, and R11 must be removed.

Table B-18. MSP-TS430RGZ48B Bill of Materials

Position	Ref Des	No. per Board	Description	Digi-Key Part No.	Comment
1	C1, C2	0	12pF, SMD0805		DNP
2	C3, C4	0	47pF, SMD0805		DNP
3	C6, C7, C12	3	10uF, 6.3V, SMD0805		
4	C5, C11, C13, C14	4	100nF, SMD0805	311-1245-2-ND	
5	C8	1	2.2nF, SMD0805		
6	C9	1	470nF, SMD0805	478-1403-2-ND	
7	D1	1	green LED, SMD0805	P516TR-ND	
8	J1, J2, J3, J4	0	12-pin header, TH	SAM1029-12-ND (Header) SAM1213-12-ND (Receptacle)	DNP: Headers and receptacles enclosed with kit. Keep vias free of solder:
9	J5	1	3-pin header, male, TH		
10	JP3, JP5, JP6, JP7, JP8, JP9, JP10	7	3-pin header, male, TH	SAM1035-03-ND	place jumpers on pins 2-3 on JP5, JP6, JP7, JP8, JP9, JP10 place jumpers on pins 1-2 on JP3,
11	JP1, JP2	2	2-pin header, male, TH	SAM1035-02-ND	Place jumper on header
12		9	Jumper	15-38-1024-ND	See Pos. 10and Pos. 11
13	JTAG	1	14-pin connector, male, TH	HRP14H-ND	
14	BOOTST	0	10-pin connector, male, TH		"DNP Keep vias free of solder"
15	Q1	0	Crystal	Micro Crystal MS3V-T1R 32.768kHz, C(Load) = 12.5pF	DNP: Q1 Keep vias free of solder
16	Q2	0	Crystal	Q2: 4MHz Buerklin: 78D134	DNP: Q2 Keep vias free of solder
17	Insulating disk to Q2	0	Insulating disk to Q2	http://www.ettinger.de/Art_Detail.cfm?ART_ARTNUM=70.08.121	
18	R3, R7	2	330 Ω, SMD0805	541-330ATR-ND	
19	R1, R2, R4, R6, R8, R9, R10, R11, R12	3	0 Ohm, SMD0805	541-000ATR-ND	DNP: R6, R8, R9, R10, R11, R12
20	R5	1	47k Ω, SMD0805	541-47000ATR-ND	
21	U1	1	Socket: QFN11T048-008_A101121_RGZ48		Manuf.: Yamaichi
22	PCB	1	81 x 76 mm		2 layers
23	Adhesive plastic feet	4	Approximately 6mm width, 2mm height	for example, 3M Bumpons Part No. SJ-5302	Apply to corners at bottom side
24	MSP430	2	MSP430F5342IRGZ		DNP: enclosed with kit, supplied by TI

B.18 MSP-TS430RGZ48C

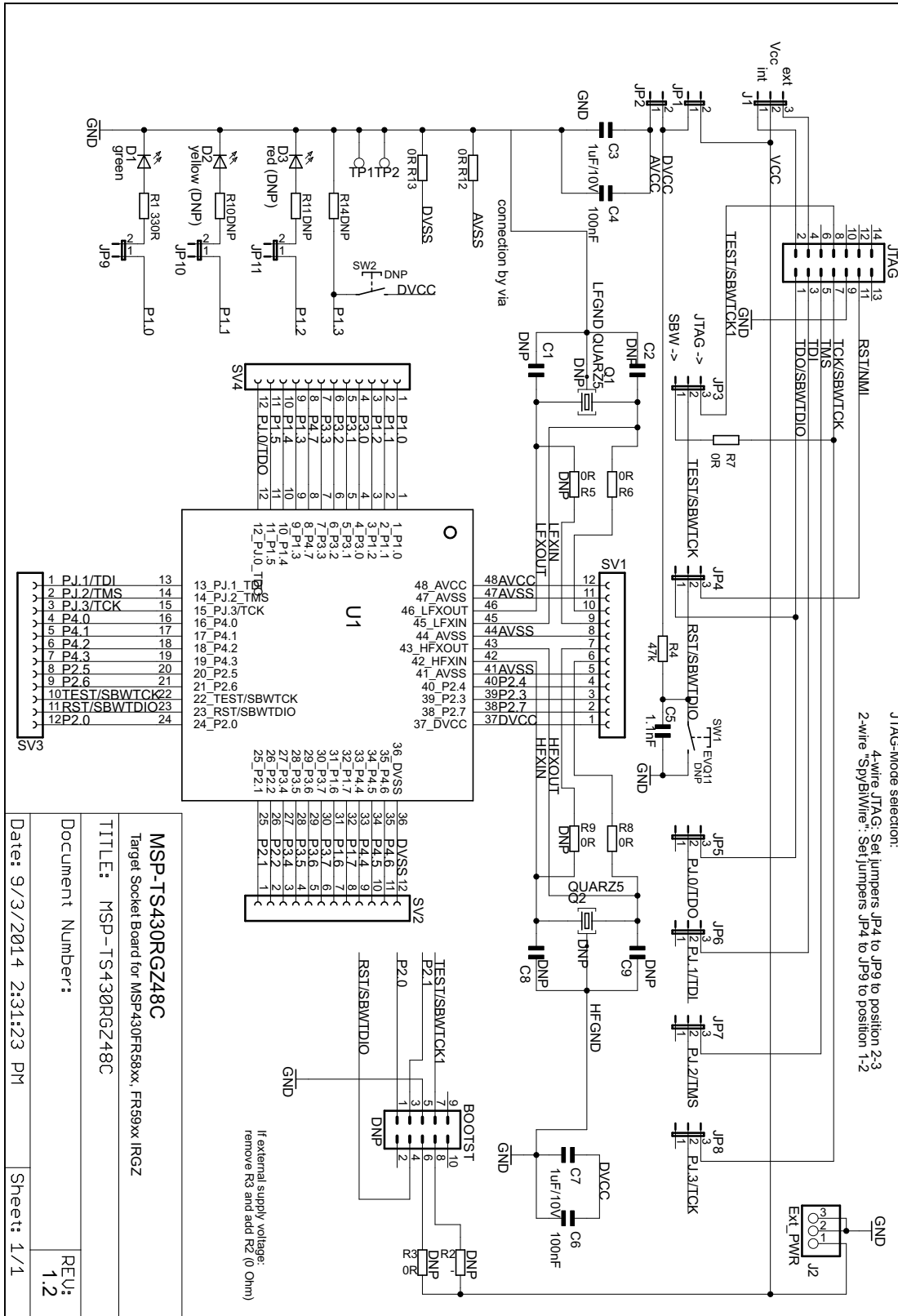

Figure B-36. MSP-TS430RGZ48C Target Socket Module, Schematic

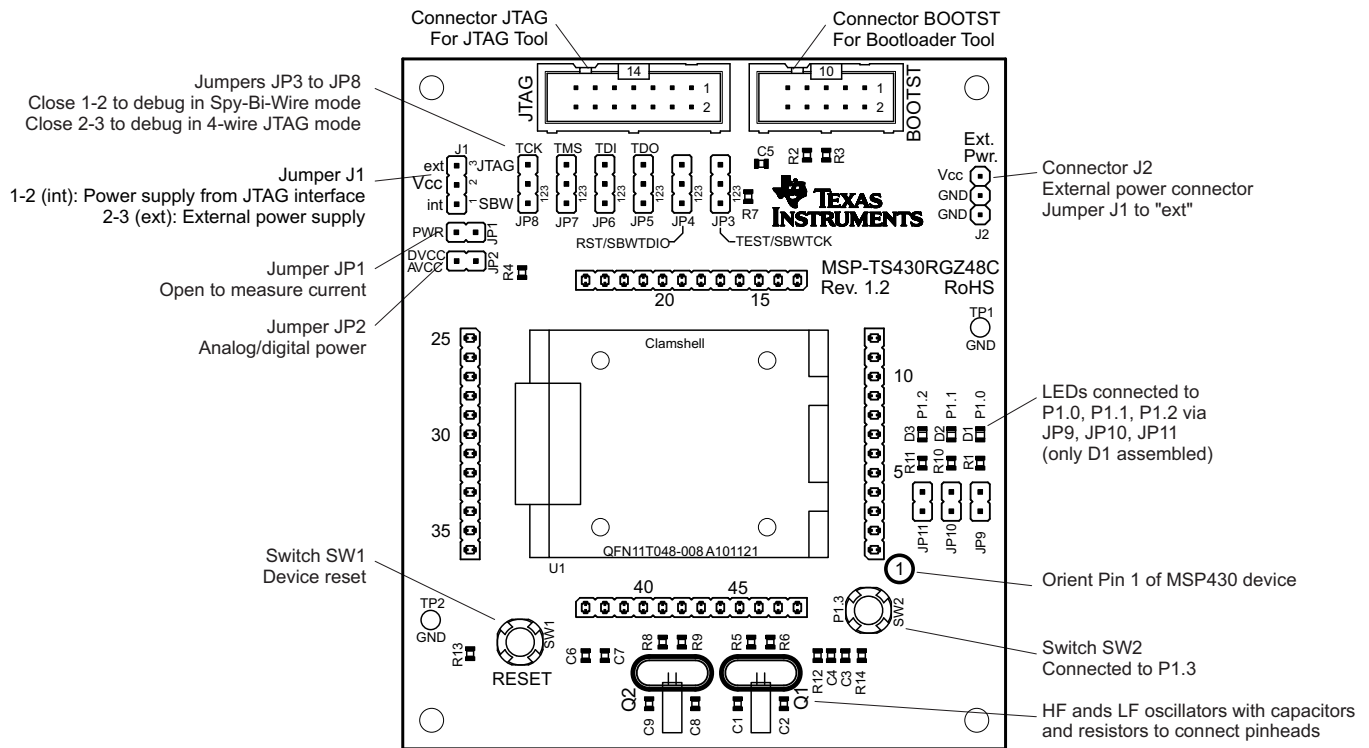

Figure B-37. MSP-TS430RGZ48C Target Socket Module, PCB

NOTE: LFOSC and HFOSC pins are swapped at SV1.

- 42_HFXIN (pin 42) → SV1 (pin 7)
- 43_HFXOUT (pin 43) → SV1 (pin 6)
- 45_LFXIN (pin 45) → SV1 (pin 10)
- 46_LFXOUT (pin 46) → SV1 (pin 9)

Table B-19. MSP-TS430RGZ48C Bill of Materials

Pos	Ref Des	Number Per Board	Description	Digi-Key Part Number	Comment
1	SV1, SV2, SV3, SV4	4	12-pin header, TH	SAM1029-12-ND	DNP: headers and receptacles enclosed with kit. Keep vias free of solder. : Header : Receptacle
1.1	SV1, SV2, SV3, SV4	4	12-pin receptable, TH	SAM1213-12-ND	DNP: headers and receptacles enclosed with kit. Keep vias free of solder. : Header : Receptacle
2	JP1, JP2, JP9	3	2-pin header, male, TH	SAM1035-02-ND	Place jumper on header
3	JP10, JP11	2	2-pin header, male, TH	SAM1035-02-ND	DNP
4	J1, JP3, JP4, JP5, JP6, JP7, JP8	7	3-pin header, male, TH	SAM1035-03-ND	Place jumpers on pins 2-3
5	J2	1	3-pin header, male, TH	SAM1035-03-ND	
6	JP1, JP2, JP9, J1, JP3, JP4, JP5, JP6, JP7, JP8	10	Jumper	15-38-1024-ND	Place on: JP1, JP2, JP9, J1, JP3, JP4, JP5, JP6, JP7, JP8
7	R2, R3, R5, R6, R8, R9, R10, R11, R14	9	DNP, 0805		DNP
8	R12, R13, R7	3	0R, 0805	541-000ATR-ND	
9	C5	1	1.1nF, CSMD0805	490-1623-2-ND	
10	C3, C7	2	1uF, 10V, CSMD0805	490-1702-2-ND	
11	R4	1	47k, 0805	541-47000ATR-ND	
12	C4, C6	2	100nF, CSMD0805	311-1245-2-ND	
13	R1	1	330R, 0805	541-330ATR-ND	
14	C1, C2, C8, C9	4	DNP, CSMD0805		DNP
15	SW1, SW2	2	EVQ-11L05R	P8079STB-ND	DNP
16	BOOTST	1	10-pin connector, male, TH	HRP10H-ND	DNP, keep vias free of solder
17	JTAG	1	14-pin connector, male, TH	HRP14H-ND	
18	Q1	1	DNP: MS3V-TR1 (32768kHz, 20ppm, 12.5pF)	depends on application	Micro Crystal, DNP, enclosed in kit, keep vias free of solder
19	Q2	1	DNP, Christal	depends on application	DNP, keep vias free of solder
20	U1	1	Socket: QFN11T048-008 A101121-001		Manuf.: Yamaichi
20.1	U1	1	MSP430FR5969IRGZ		DNP: enclosed with kit. Is supplied by TI.
21	D1	1	green LED, DIODE0805	P516TR-ND	
22	D3	1	red (DNP), DIODE0805		DNP
23	D2	1	yellow (DNP), DIODE0805		DNP
24	TP1, TP2	2	Testpoint		DNP, keep pads free of solder
25	Rubber stand off	4		Buerklin: 20H1724	apply to corners at bottom side
26	PCB	1	79.6 x 91.0 mm	MSP-TS430RGZ48C Rev. 1.2	2 layers, black solder mask

B.19 MSP-TS430PM64

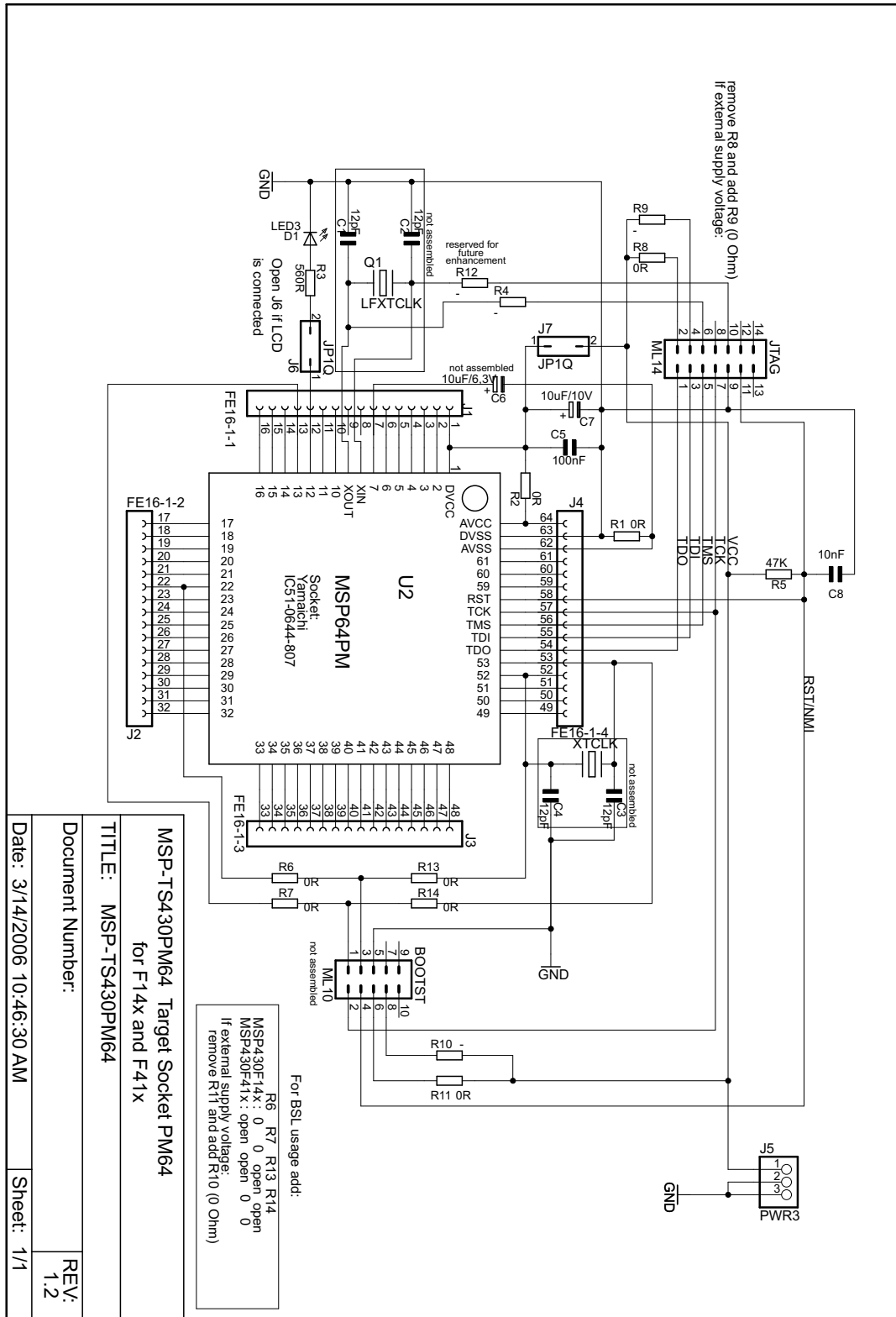

NOTE: Connections between the JTAG header and pins XOUT and XIN are no longer required and should not be made.

Figure B-38. MSP-TS430PM64 Target Socket Module, Schematic

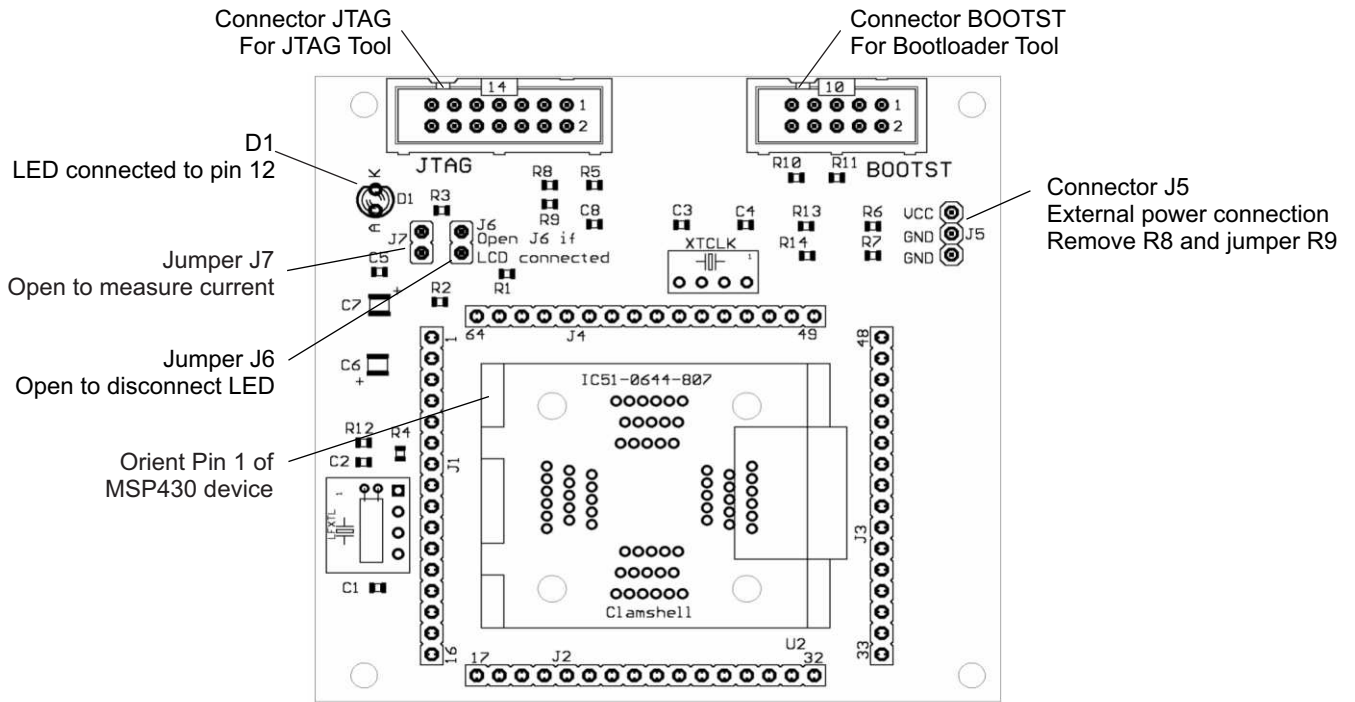

Figure B-39. MSP-TS430PM64 Target Socket Module, PCB

Table B-20. MSP-TS430PM64 Bill of Materials

Pos.	Ref Des	No. per Board	Description	Digi-Key Part No.	Comment
1	C1, C2	0	12pF, SMD0805		DNP
1.1	C3, C4	0	47pF, SMD0805		DNP: Only recommendation. Check your crystal spec.
2	C6, C7	1	10uF, 10V, Tantal Size B	511-1463-2-ND	DNP: C6
3	C5	1	100nF, SMD0805	478-3351-2-ND	
4	C8	1	10nF, SMD0805	478-1383-2-ND	
5	C9	1	470nF, SMD0805	478-1403-2-ND	
6	D1	1	green LED, SMD0805	P516TR-ND	
7	J1, J2, J3, J4	0	16-pin header, TH	SAM1029-16-ND SAM1213-16-ND	DNP: Headers and receptacles enclosed with kit. Keep vias free of solder. : Header : Receptacle
8	J5	1	3-pin header, male, TH	SAM1035-03-ND	
9	J6, J7	2	2-pin header, male, TH	SAM1035-02-ND	Place jumper on header
11		2	Jumper	15-38-1024-ND	Place on: J6, J7
12	JTAG	1	14-pin connector, male, TH	HRP14H-ND	
13	BOOTST	0	10-pin connector, male, TH		DNP: Keep vias free of solder
14	Q1, Q2	0	Crystal	Q1: Micro Crystal MS1V-T1K 32.768kHz, C(Load) = 12.5pF	DNP: Keep vias free of solder
15	R3	1	330 Ω , SMD0805	541-330ATR-ND	
16	R1, R2, R4, R6, R7, R8, R9, R10, R11, R12, R13, R14	3	0 Ω , SMD0805	541-000ATR-ND	DNP: R4, R6, R7, R9, R10, R11, R12, R13, R14
17	R5	1	47k Ω , SMD0805	541-47000ATR-ND	
18	U1	1	Socket: IC51-0644-807		Manuf.: Yamaichi
19	PCB	1	78 x 75 mm		2 layers
20	Rubber standoff	4		select appropriate	Apply to corners at bottom side
21	MSP430	22	MSP430F2619IPM MSP430F417IPM		DNP: Enclosed with kit supplied by TI

B.20 MSP-TS430PM64A

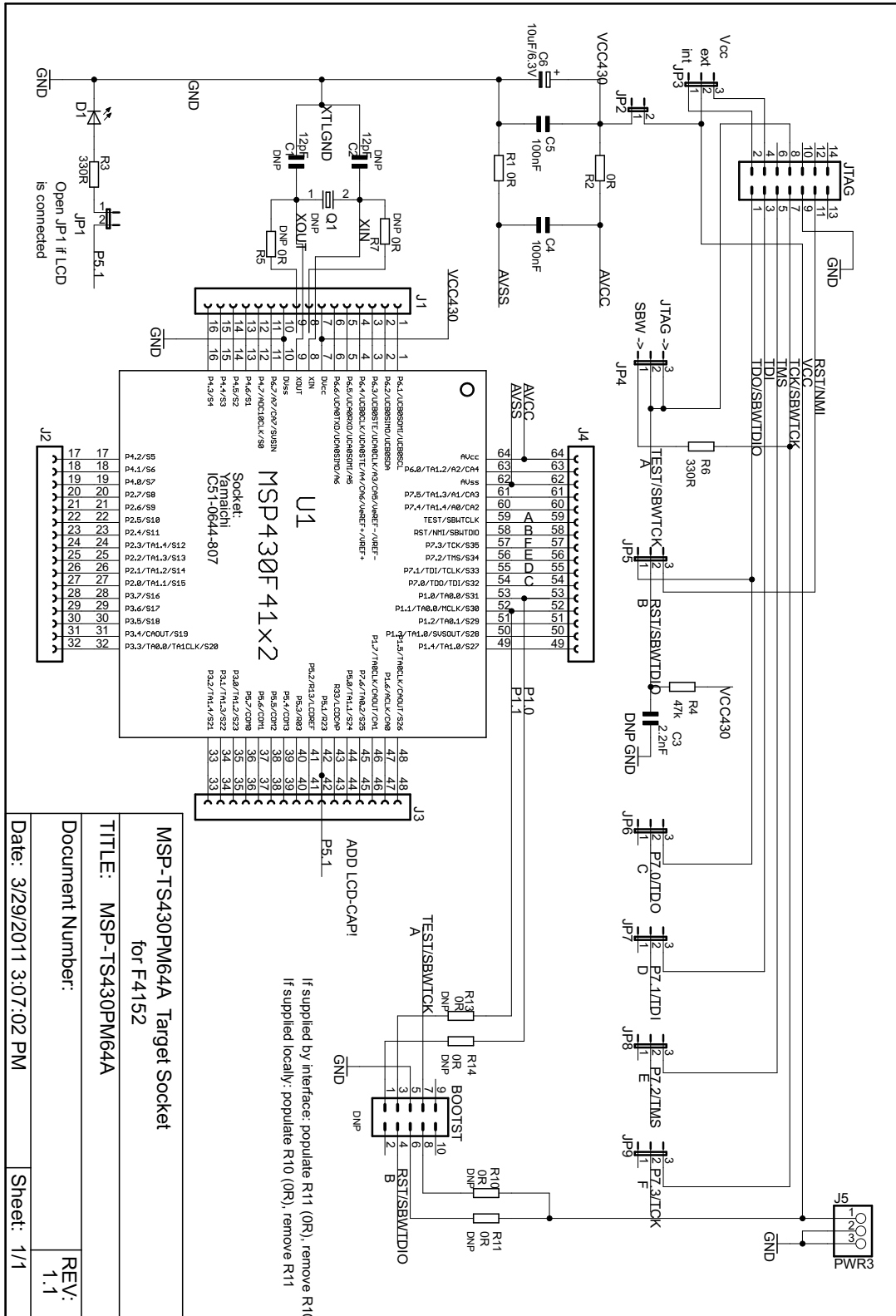

Figure B-40. MSP-TS430PM64A Target Socket Module, Schematic

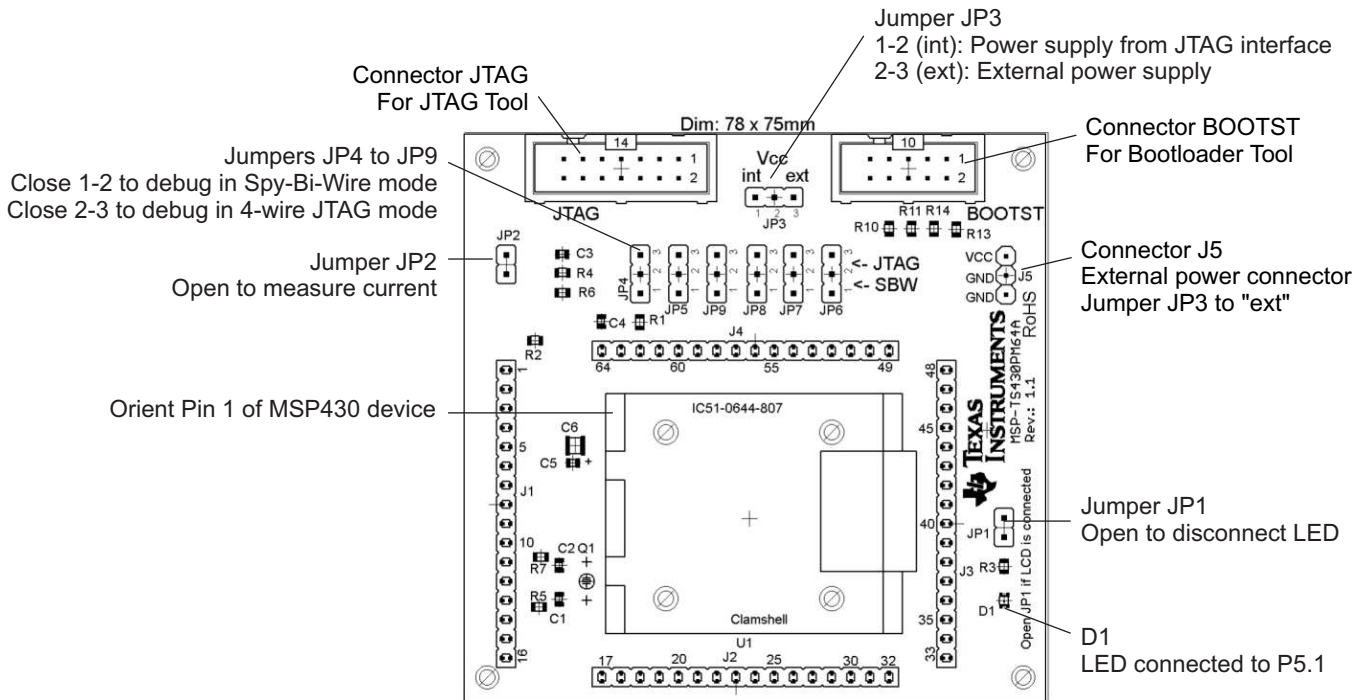

Figure B-41. MSP-TS430PM64A Target Socket Module, PCB

Table B-21. MSP-TS430PM64A Bill of Materials

Pos.	Ref Des	No. per Board	Description	Digi-Key Part No.	Comment
1	C1, C2,	0	12pF, SMD0805		DNP
2	C3	0	2.2nF, SMD0805		DNP
3	C6,	1	10uF, 10V, Tantal Size B	511-1463-2-ND	
4	C4, C5	2	100nF, SMD0805	478-3351-2-ND	
5	D1	1	green LED, SMD0805	P516TR-ND	
6	J1, J2, J3, J4	0	16-pin header, TH	SAM1029-16-ND SAM1213-16-ND	DNP: Headers and receptacles enclosed with kit. Keep vias free of solder. : Header : Receptacle
7	J5, JP3, JP4, JP5, JP6, JP7, JP8, JP9	8	3-pin header, male, TH	SAM1035-03-ND	
8	JP1, JP2	2	2-pin header, male, TH	SAM1035-02-ND	Place jumper on header
9		2	Jumper	15-38-1024-ND	Place on: J6, J7
10	JTAG	1	14-pin connector, male, TH	HRP14H-ND	
11	BOOTST	0	10-pin connector, male, TH		DNP: Keep vias free of solder
12	Q1	0	Crystal	Micro Crystal MS1V-T1K 32.768kHz, C(Load) = 12.5pF	DNP: Keep vias free of solder
13	R3, R6	2	330 Ω , SMD0805	541-330ATR-ND	
14	R1, R2, R5, R7, R9, R10, R11, R13, R14	2	0 Ω , SMD0805	541-000ATR-ND	DNP: R5, R7, R9, R10, R11, R13, R14
15	R4	1	47k Ω , SMD0805	541-47000ATR-ND	
16	U1	1	Socket: IC51-0644-807		Manuf.: Yamaichi
17	PCB	1	78 x 75 mm		4 layers
18	Rubber stand off	4		select appropriate	Apply to corners at bottom side
19	MSP430	2	MSP430F4152IPM		DNP: Enclosed with kit supplied by TI

B.21 MSP-TS430PM64D

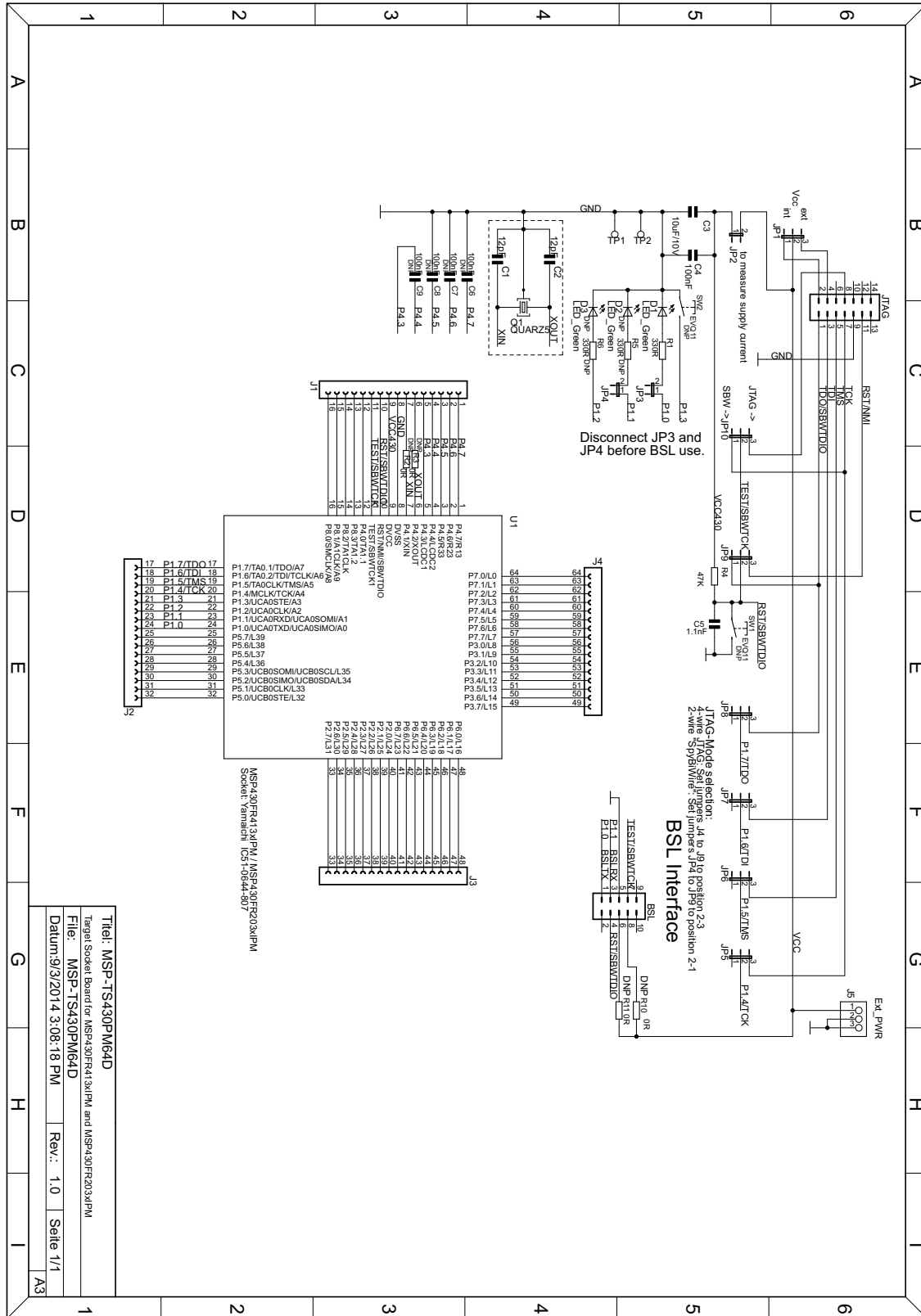

Figure B-42. MSP-TS430PM64D Target Socket Module, Schematic

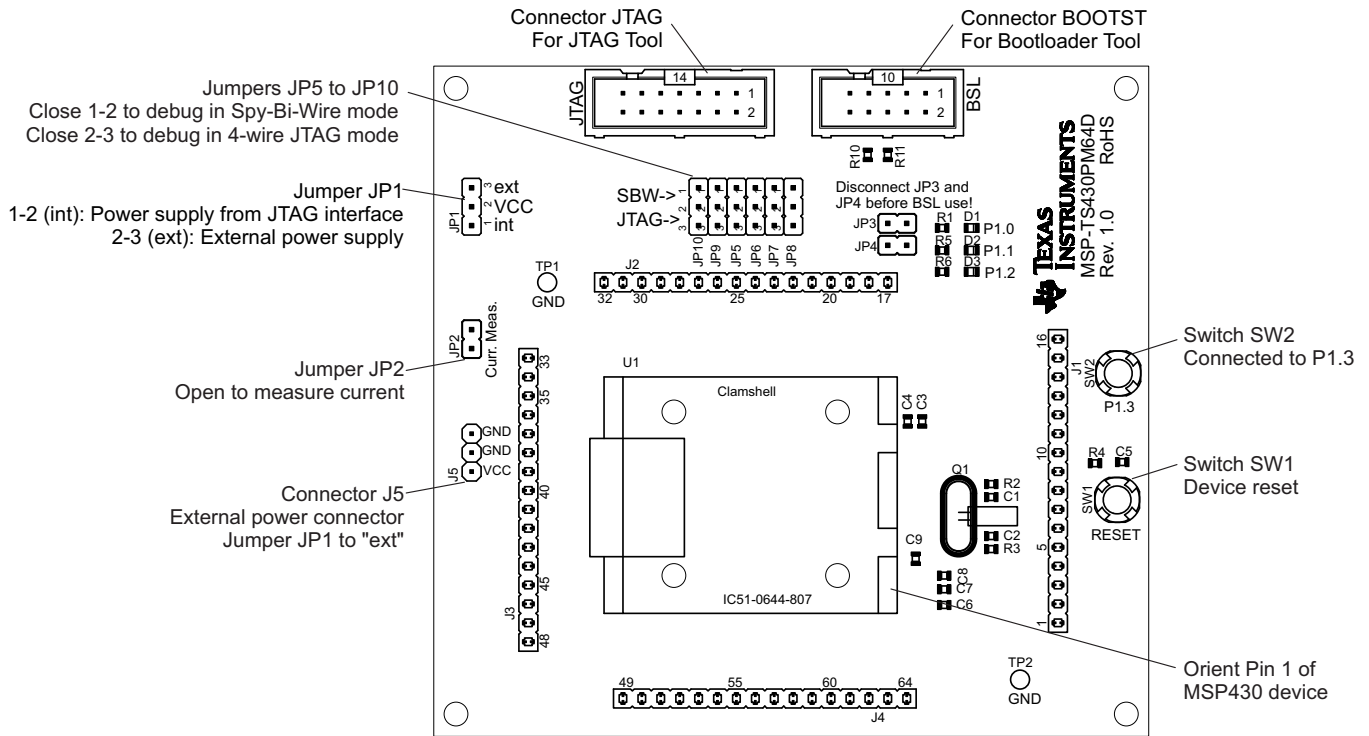

Figure B-43. MSP-TS430PM64D Target Socket Module, PCB

NOTE: For bootloader use, the BSL connector and only one of the resistors R10 or R11 must be populated. If the board is supplied internally, R11 (0 Ω) must be assembled. If the board is supplied externally, R10 (0 Ω) must be assembled, and R11 must be removed.

Table B-22. MSP-TS430PM64D Bill of Materials

Pos.	Ref Des	No. per Board	Description	Digi-Key Part No.	Comment
1	PCB	1	90x96 mm	MSP-TS430PM64D Rev. 1.0	2 layers, 90x96mm, white solder mask
2	BSL	1	10-pin connector, male, TH	HRP10H-ND	DNP, keep vias free of solder
3	D1	1	Green LED, HSMG-C170, DIODE0805	516-1434-1-ND	Avago, Farnell 5790852
4	D2, D3	2	LED, DIODE0805		DNP
5	JP2, JP3, JP4	3	2-pin header, male, TH	SAM1035-02-ND	place jumper on header
6	JP1, JP5, JP6, JP7, JP8, JP9, JP10	7	3-pin header, male, TH	SAM1035-03-ND	place jumpers on pins 2-3 (JTAG)
7	R1	1	330R, 0805	541-330ATR-ND	
8	R5, R6	2	330R, 0805	541-330ATR-ND	DNP
9	R2, R3, R10, R11	4	0R, 0805	541-0.0ATR-ND	DNP
10	R4	1	47K, 0805	311-47KARTR-ND	
11	C1, C2	2	12pF, CSMD0805	709-1169-2-ND	
12	C3	1	10uF/10V, CSMD0805	445-1371-2-ND	
13	C4	1	100nF, CSMD0805	311-1245-2-ND	
14	C6, C7, C8, C9	4	100nF, CSMD0805	311-1245-2-ND	DNP
15	C5	1	1.1nF, CSMD0805	490-1623-2-ND	
16	J1, J2, J3, J4	1	16-pin header, TH	SAM1029-16-ND	DNP: headers and receptacles, enclosed with kit. Keep vias free of solder.
17	J1, J2, J3, J4	1	16-pin receptable, TH	SAM1213-16-ND	DNP: headers and receptacles, enclosed with kit. Keep vias free of solder.
18	JTAG	1	14-pin connector, male, TH	HRP14H-ND	
19	U1	1	Socket IC51-0644-807		Manuf.: Yamaichi
20	U1	2	MSP430FR4133IPM		DNP: enclosed with kit. Is supplied by TI.
21	J5	1	3-pin header, male, TH	SAM1035-03-ND	
22	Q1	1	Microcrystal 32768Hz, MS3V-T1R (32.768kHz, 20ppm, 12.5pF)		
23	SW1, SW2	2	Panasonic EVQ11	P8079STB-ND	DNP, Lacon: 1251459
24	Rubber stand off	4		Buerklin: 20H1724	apply to corners at bottom side

B.22 MSP-TS430PM64F

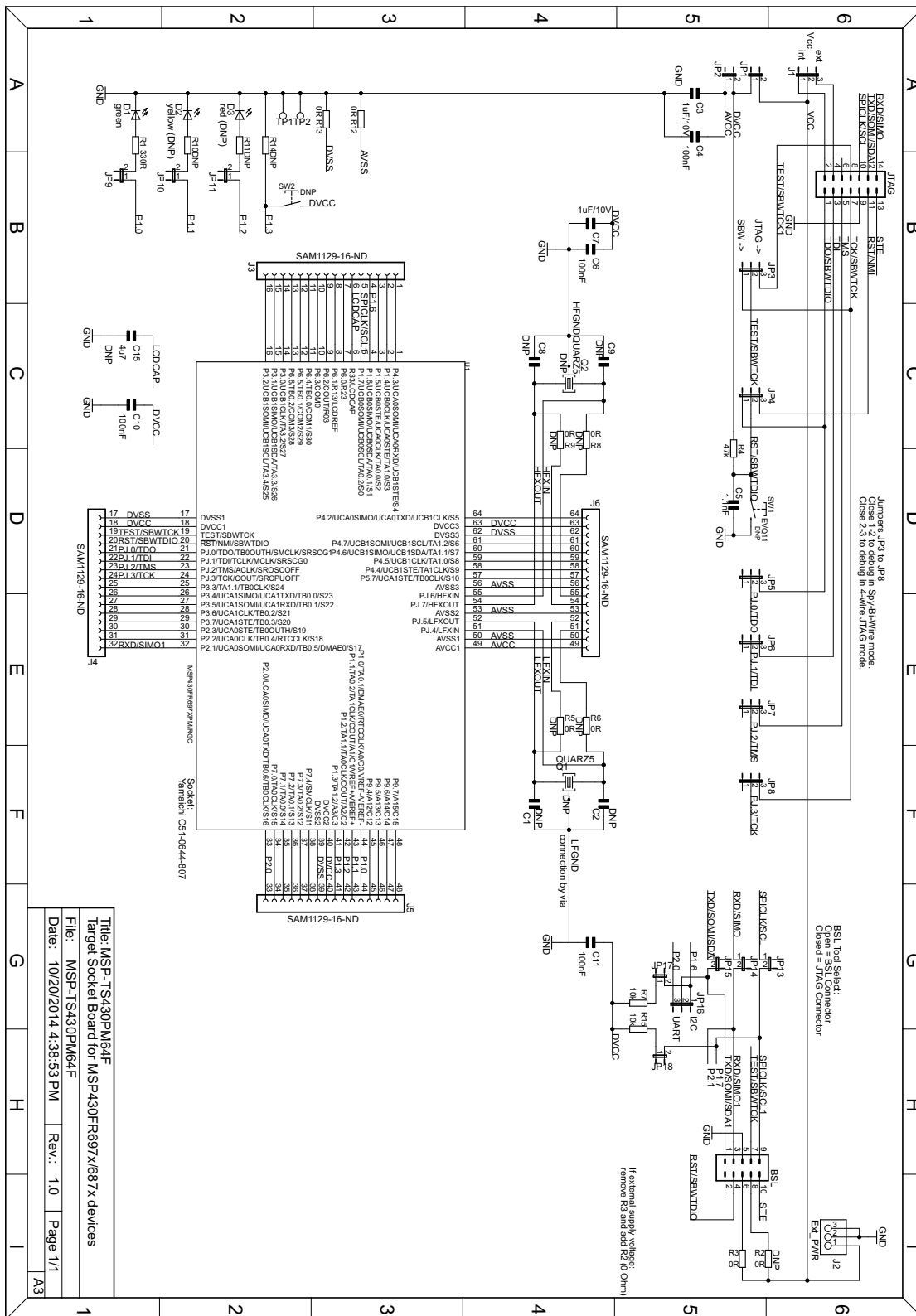
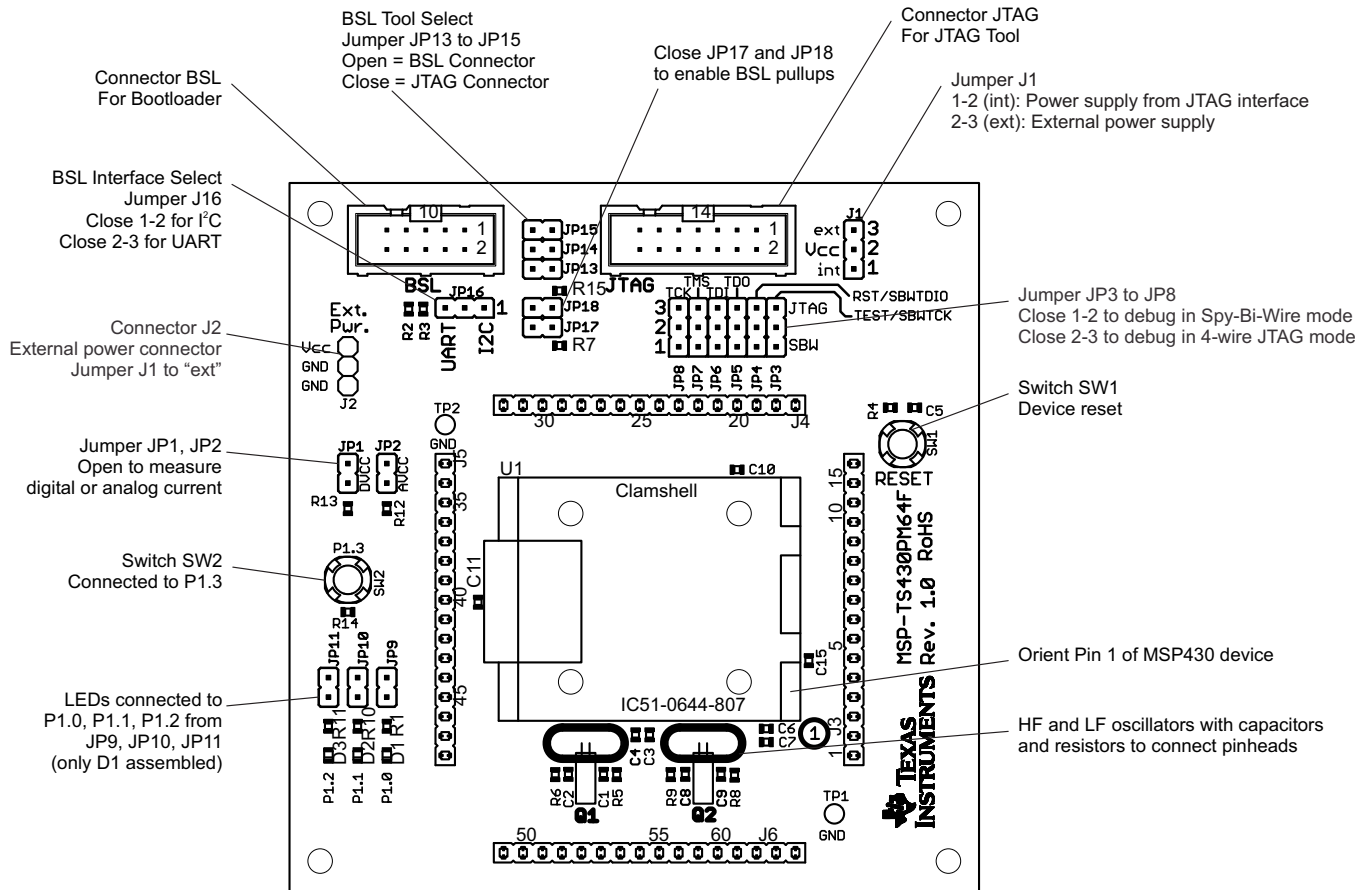

Figure B-44. MSP-TS430PM64F Target Socket Module, Schematic



This target board supports UART or I²C BSL configuration. To select the configuration to use, set the jumpers as shown in the following table.

Jumper Configuration	UART BSL Configuration	I ² C BSL Configuration
JP17 and JP18	Open	Close
JP16	Close 2-3 (UART)	Close 1-2 (I2C)

Figure B-45. MSP-TS430PM64F Target Socket Module, PCB

Table B-23. MSP-TS430PM64F Bill of Materials (BOM)

Pos.	Ref Des	Number per Board	Description	DigiKey Part Number	Comment
1	PCB	1	90.0 x 92.5 mm	MSP-TS430PM64F Rev. 1.0	2 layers, purple solder mask
2	JP1, JP2, JP9, JP13, JP14, JP15,	6	2-pin header, male, TH	SAM1035-02-ND	place jumper on header
3	JP17, JP18	2	2-pin header, male, TH	SAM1035-02-ND	place jumper on header's pin1 only
4	JP10, JP11	2	2-pin header, male, TH	SAM1035-02-ND	DNP, keep pads free of solder
5	J1	1	3-pin header, male, TH	SAM1035-03-ND	place jumpers on pins 1-2
6	JP3, JP4, JP5, JP6, JP7, JP8, JP16	7	3-pin header, male, TH	SAM1035-03-ND	place jumpers on pins 2-3
7	J2	1	3-pin header, male, TH	SAM1035-03-ND	
8	R2, R5, R6, R8, R9	5	0R, 0805	541-0.0ATR-ND	DNP
9	R3, R12, R13	3	0R, 0805	541-0.0ATR-ND	
10	C5	1	1.1nF, CSMD0805	490-1623-2-ND	
11	C3, C7	2	1uF/10V, CSMD0805	490-1702-2-ND	
12	C15	1	4u7, CSMD0805	445-1370-1-ND	DNP
13	R7, R15	1	10k, 0805	541-10KATR-ND	
14	R4	1	47k, 0805	541-47KATR-ND	
15	C4, C6, C10, C11	4	100nF, CSMD0805	490-1666-1-ND	
16	R1	1	330R, 0805	541-330ATR-ND	
17	R10, R11	2	330R, 0805	541-330ATR-ND	DNP
18	R14	1	47k, 0805	541-47KATR-ND	DNP
19	C1, C2, C8, C9	4	DNP, CSMD0805		DNP
20	SW2	1	EVQ-11L05R	P8079STB-ND	DNP, Lacon: 1251459
21	SW1	1	EVQ-11L05R	P8079STB-ND	DNP, Lacon: 1251459
22	J3, J4, J5, J6	4	16-pin header, TH	SAM1029-16-ND	DNP: headers enclosed with kit. Keep vias free of solder.
23	J3, J4, J5, J6	4	16-pin receptacle, TH	SAM1213-16-ND	DNP: receptacles enclosed with kit. Keep vias free of solder.
24	TP1, TP2	2	Testpoint		DNP, keep pads free of solder
25	BSL	1	10-pin connector, male, TH	HRP10H-ND	
26	JTAG	1	14-pin connector, male, TH	HRP14H-ND	
27	U1	1	Socket:IC51-0644-807		Manuf. Yamaichi
28	U1	2	MSP430FR6972IPMR		DNP: enclosed with kit. Is supplied by TI.
29	Q1	1	DNP: MS3V-TR1 (32,768kHz/ 20ppm/12,5pF)	depends on application	Micro Crystal, DNP, enclosed in kit, keep vias free of solder
30	Q2	1	DNP, Crystal	depends on application	DNP, keep vias free of solder
31	D1	1	green LED, HSMG-C170 DIODE0805	516-1434-1-ND	Avago, Farnell 5790852
32	D3	1	red (DNP), DIODE0805		DNP
33	D2	1	yellow (DNP), DIODE0805		DNP
34	Rubber stand off	4		Buerklin: 20H1724	apply to corners at bottom side

B.23 MSP-TS430RGC64B

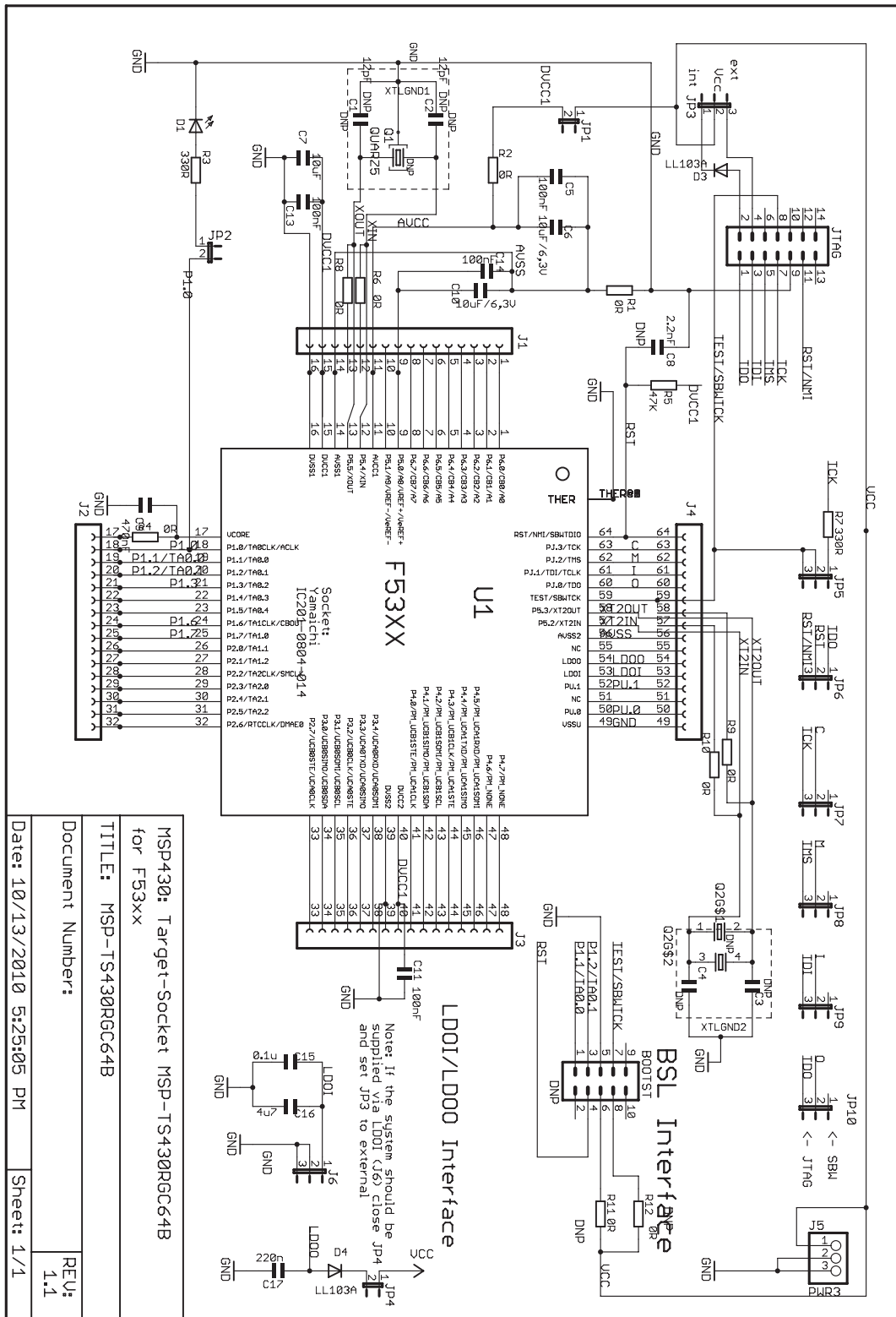

Figure B-46. MSP-TS430RGC64B Target Socket Module, Schematic

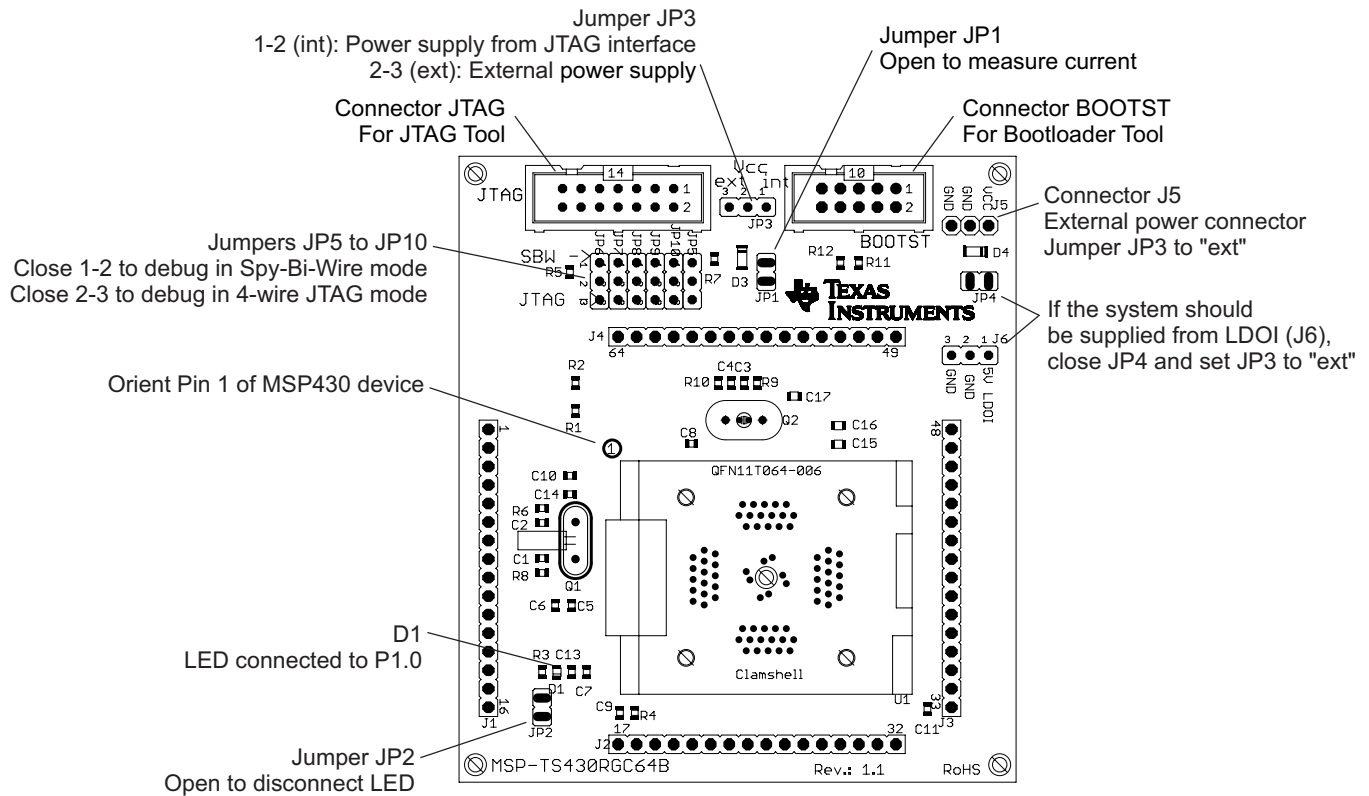

Figure B-47. MSP-TS430RGC64B Target Socket Module, PCB

NOTE: For bootloader use, the BSL connector and only one of the resistors R11 or R12 must be populated. If the board is supplied internally, R11 (0 Ω) must be assembled. If the board is supplied externally, R12 (0 Ω) must be assembled, and R11 must be removed.

Table B-24. MSP-TS430RGC64B Bill of Materials

Pos.	Ref Des	No. per Board	Description	Digi-Key Part No.	Comment
1	C1, C2	0	12pF, SMD0805		DNP
2	C3, C4	0	47pF, SMD0805		DNP
3	C6, C7, C10	3	10uF, 6.3V, SMD0805		
4	C5, C11, C13, C14, C15	5	100nF, SMD0805	311-1245-2-ND	
5	C8	1	2.2nF, SMD0805		
6	C9	1	470nF, SMD0805	478-1403-2-ND	
7	C16	1	4.7uF, SMD0805		
8	C17	1	220nF, SMD0805		
9	D1	1	green LED, SMD0805	P516TR-ND	
10	J1, J2, J3, J4	0	16-pin header, TH	SAM1029-16-ND (Header) SAM1213-16-ND (Receptacle)	DNP: Headers and receptacles enclosed with kit. Keep vias free of solder:
11	J5, J6	2	3-pin header, male, TH		
12	JP3, JP5, JP6, JP7, JP8, JP9, JP10	7	3-pin header, male, TH	SAM1035-03-ND	place jumpers on pins 2-3 on JP5, JP6, JP7, JP8, JP9, JP10 place jumpers on pins 1-2 on JP3,
13	JP1, JP2, JP4	3	2-pin header, male, TH	SAM1035-02-ND	Place jumper on header
14		10	Jumper	15-38-1024-ND	See Pos. 12 and Pos. 13
15	JTAG	1	14-pin connector, male, TH	HRP14H-ND	
16	BOOTST	0	10-pin connector, male, TH		"DNP Keep vias free of solder"
17	Q1	0	Crystal	Micro Crystal MS3V-T1R 32.768kHz, C(Load) = 12.5pF	DNP: Q1 Keep vias free of solder
18	Q2	0	Crystal	Q2: 4MHz Buerklin: 78D134	DNP: Q2 Keep vias free of solder
19	Insulating disk to Q2	0	Insulating disk to Q2	http://www.ettinger.de/Art_Detail.cfm?ART_ARTNUM=70.08.121	
20	R3, R7	2	330 Ω, SMD0805	541-330ATR-ND	
21	R1, R2, R4, R6, R8, R9, R10, R11, R12	3	0 Ohm, SMD0805	541-000ATR-ND	DNP: R6, R8, R9, R10, R11, R12
22	R5	1	47k Ω, SMD0805	541-47000ATR-ND	
23	U1	1	Socket: QFN11T064-006-N-HSP		Manuf.: Yamaichi
24	PCB	1	85 x 76 mm		2 layers
25	Adhesive plastic feet	4	Approximately 6mm width, 2mm height	for example, 3M Bumpons Part No. SJ-5302	Apply to corners at bottom side
26	D3, D4				
27	MSP430	2	MSP430F5310 RGC		DNP: enclosed with kit, supplied by TI

B.24 MSP-TS430RGC64C

The MSP-TS430RGC64C target board has been designed with the option to operate with the target device DVIO input voltage supplied via header J6 (see [Figure B-48](#)). This development platform does not supply the 1.8-V DVIO rail on board and it **MUST** be provided by external power supply for proper device operation. For correct JTAG connection, programming, and debug operation, it is important to follow this procedure:

1. Make sure that the VCC and DVIO voltage supplies are OFF and that the power rails are fully discharged to 0 V.
2. Enable the 1.8-V external DVIO power supply.
3. Enable the 1.8-V to 3.6-V VCC power supply (alternatively, this supply can be provided from the MSP-FET430UIF JTAG debugger interface).
4. Connect the MSP-FET430UIF JTAG connector to the target board.
5. Start the debug session using IAR or CCS IDE.

For more information on debugging the MSP4 and MSP430F525x, see the device-specific data sheets (MSP430F522x: [SLAS718](#); MSP430F525x: [SLAS903](#)) and *Designing with MSP430F522x and MSP430F521x Devices* ([SLAA558](#)).

For debugging of devices (MSP430F524x and MSP430F523x) without use of the DVIO power domain, short JP4 with the jumper.

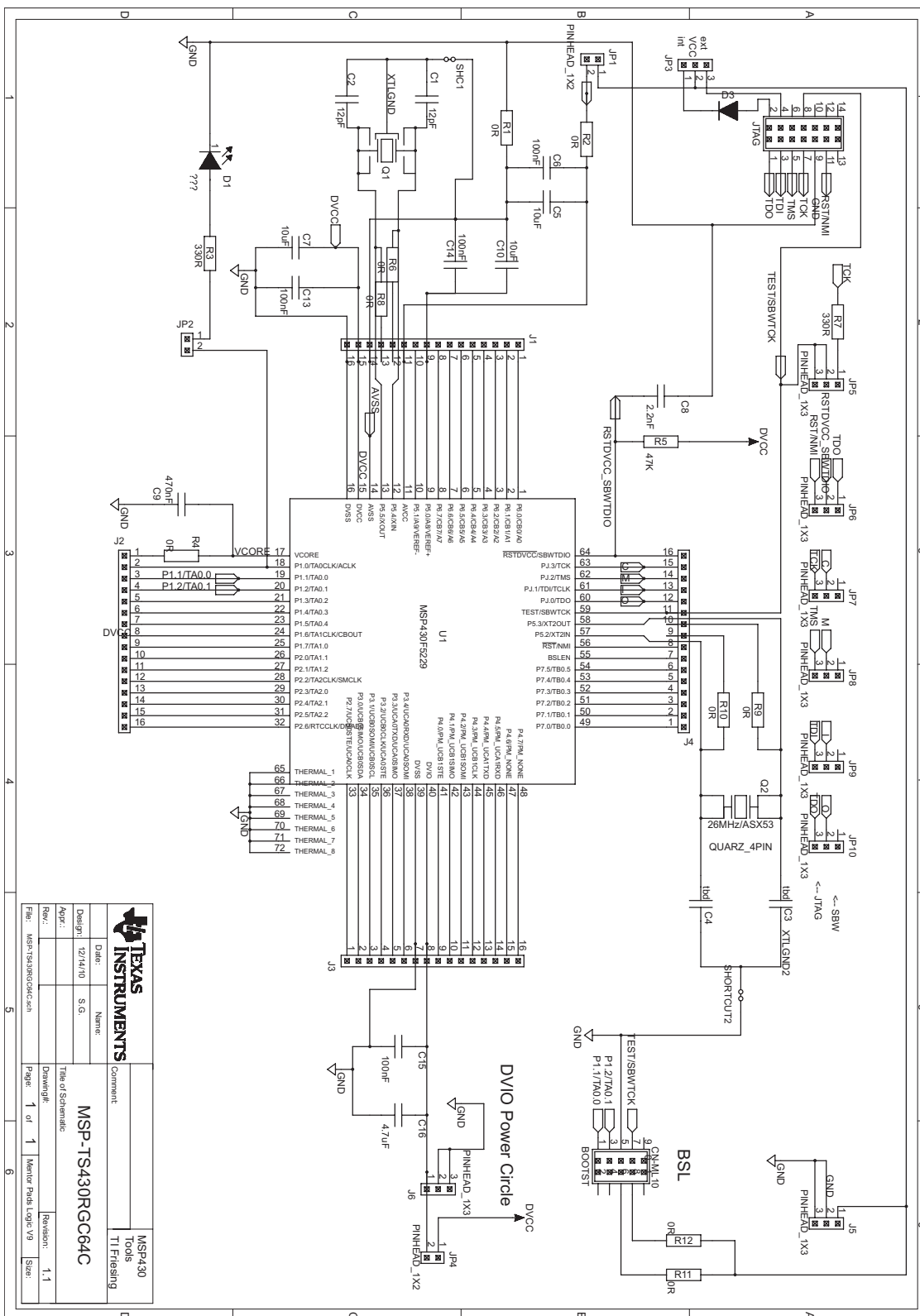

Figure B-48. MSP-TS430RGC64C Target Socket Module, Schematic

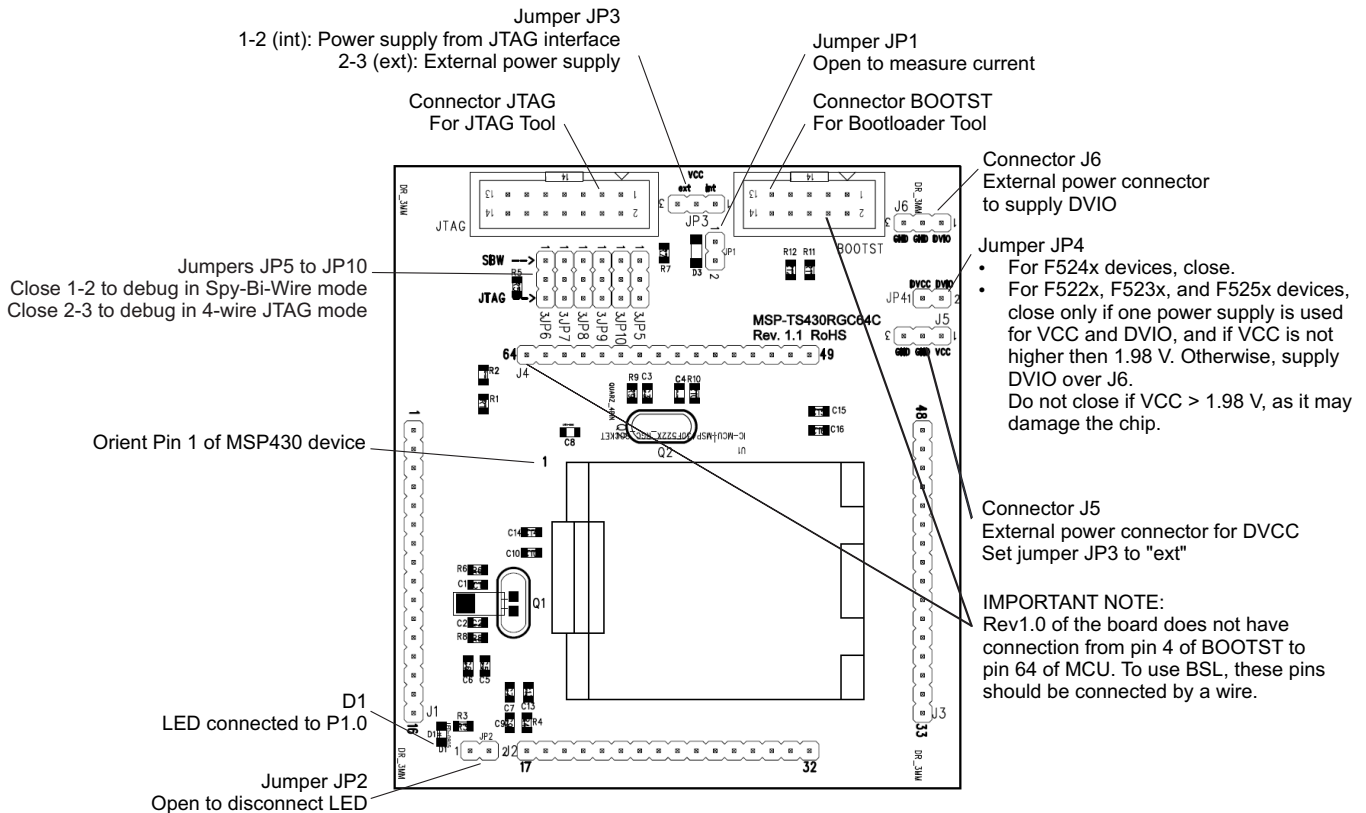

Figure B-49. MSP-TS430RGC64C Target Socket Module, PCB

NOTE: For bootloader use, the BSL connector and only one of the resistors R11 or R12 must be populated. If the board is supplied internally, R11 (0 Ω) must be assembled. If the board is supplied externally, R12 (0 Ω) must be assembled, and R11 must be removed.

Table B-25. MSP-TS430RGC64C Bill of Materials

Item	Qty	Reference	Value	Description	Comment	Supplier No.
1	0	C1, C2	12pF	CAP, SMD, Ceramic, 0805	DNP C1 C2	
2	0	C3, C4		CAP, SMD, Ceramic, 0805	DNP C3 C4	
4	3	C5, C7, C10	10uF	CAP, SMD, Ceramic, 0805		
5	5	C8 C6 C13-15	100nF	CAP, SMD, Ceramic, 0805		Digi-Key: 311-1245-2-ND
5	5	C8	2.2nF	CAP, SMD, Ceramic, 0805		
6	1	C9	470nF	CAP, SMD, Ceramic, 0805		Digi-Key: 478-1403-2-ND
7	1	C16	4.7uF	CAP, SMD, Ceramic, 0805		
8	1	D1	Green LED	LED, SMD, 0805		
9	4	J1-J4	16-pin header	Pin header 1x16: Grid: 100mil (2.54 mm)	DNP: headers and receptacles enclosed with kit. Keep vias free of solder. : Header : Receptacle	SAM1029-16-ND SAM1213-16-ND
10	2	J5, J6	3-pin header, male, TH	Pin header 1x3: Grid: 100mil (2.54 mm)		SAM1035-03-ND
11		JP5, JP6, JP7, JP8, JP9, JP10	3-pin header, male, TH	Pinheader 1x3: Grid: 100mil (2.54 mm)	place jumpers on pins 2-3	SAM1035-03-ND
12		JP3	3-pin header, male, TH	Pin header 1x3: Grid: 100mil (2.54 mm)	place jumper on pins 1-2	SAM1035-03-ND
13		JP1, JP2, JP4	2-pin header, male, TH	Pin header 1x2: Grid: 100mil (2.54 mm)	place jumper on header	SAM1035-02-ND
14	10		Jumper		Place on: JP1, JP2, JP3, JP4, JP5, JP6, JP7, JP8, JP9, JP10	15-38-1024-ND
15	1	JTAG	2x7Pin,Wanne	Header, THD, Male 2x7 Pin, Wanne, 100mil spacing		HRP14H-ND
16	0	BOOTST	2x5Pin,Wanne	Header, THD, Male 2x5 Pin, Wanne, 100mil spacing		DNP
17	1	Q1	26MHz/ASX53	CRYSTAL, SMD, 5x3MM, 26MHz		Only Kit.
18	0	Q2	26MHz/ASX53	CRYSTAL, SMD, 5x3MM, 26MHz		300-8219-1-ND
19	1	D3	LL103A	DIODE, SMD, SOD123, Schottky		Buerklin: 24S3406
20	2	R3, R7	330 Ohm, SMD0805			541-330ATR-ND
21	1	R5	47k Ohm, SMD0805	RES, SMD, 0805, 1/8W, x%		541-47000ATR-ND
22		R1, R2, R4, R6, R8, R9, R10, R11, R12	0 Ohm, SMD0805	RES, SMD, 0805, 1/8W, x%	DNP: R6, R8, R9, R10, R11,R12	541-000ATR-ND
23	1	U1		Socket: QFN11T064-006-N-HSP	Manuf.: Yamaichi	
24	2	MSP430	MSP430F5229IRGCR	IC, MCU, SMD, 9.15x9.15mm Thermal Pad with Socket		
25	4	Rubber stand off	Rubber stand off		apply to corners at bottom side	Buerklin: 20H1724
26	1	PCB	84 x 76 mm	84 x 76 mm		

B.25 MSP-TS430RGC64USB

Due to the use of diodes in the power chain, the voltage on the MSP430F5xx device is approximately 0.3 V lower than is set by the debugging tool. Set the voltage in the IDE to 0.3 V higher than desired; for example, to run the MCU at 3.0 V, set it to 3.3 V.

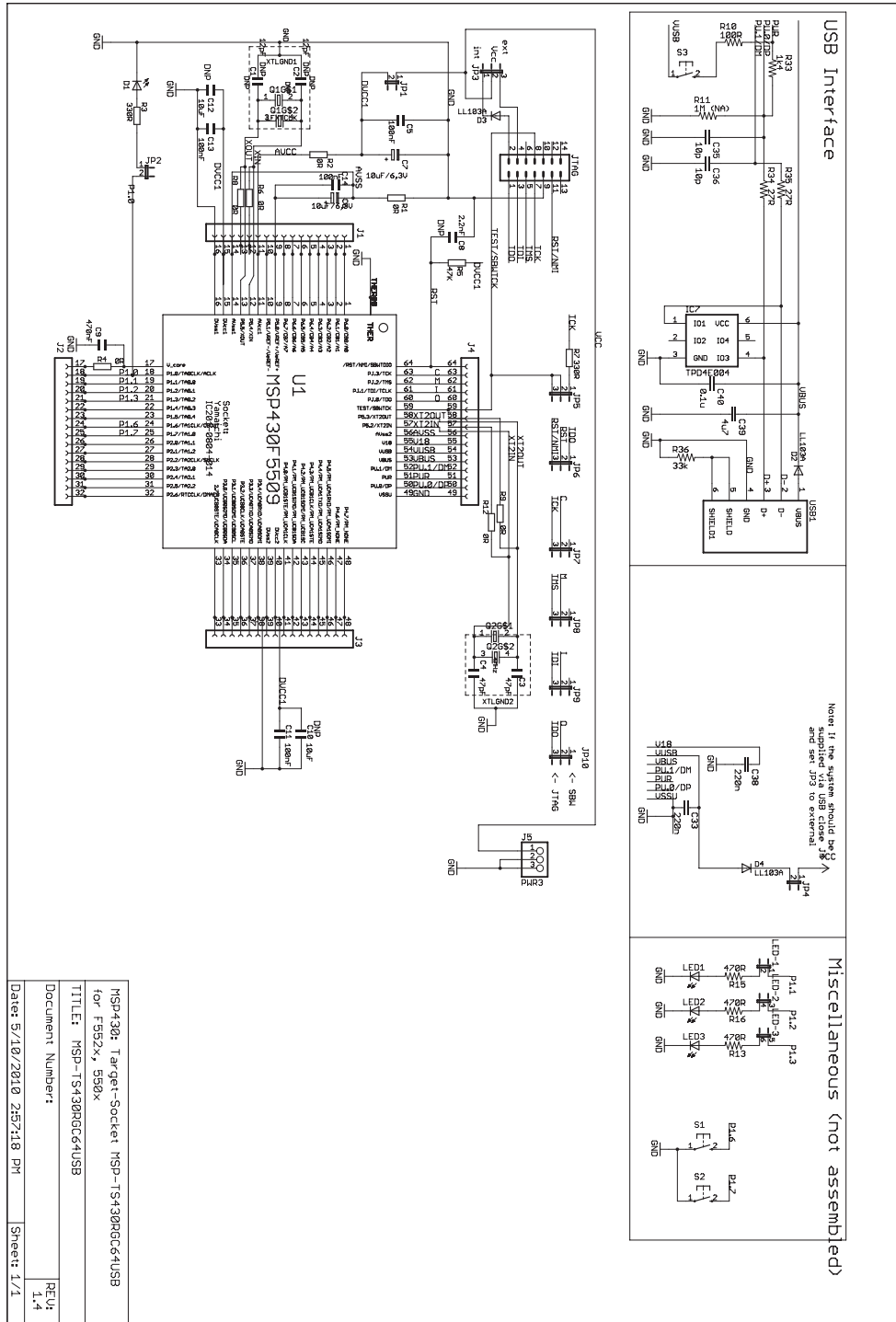

Figure B-50. MSP-TS430RGC64USB Target Socket Module, Schematic

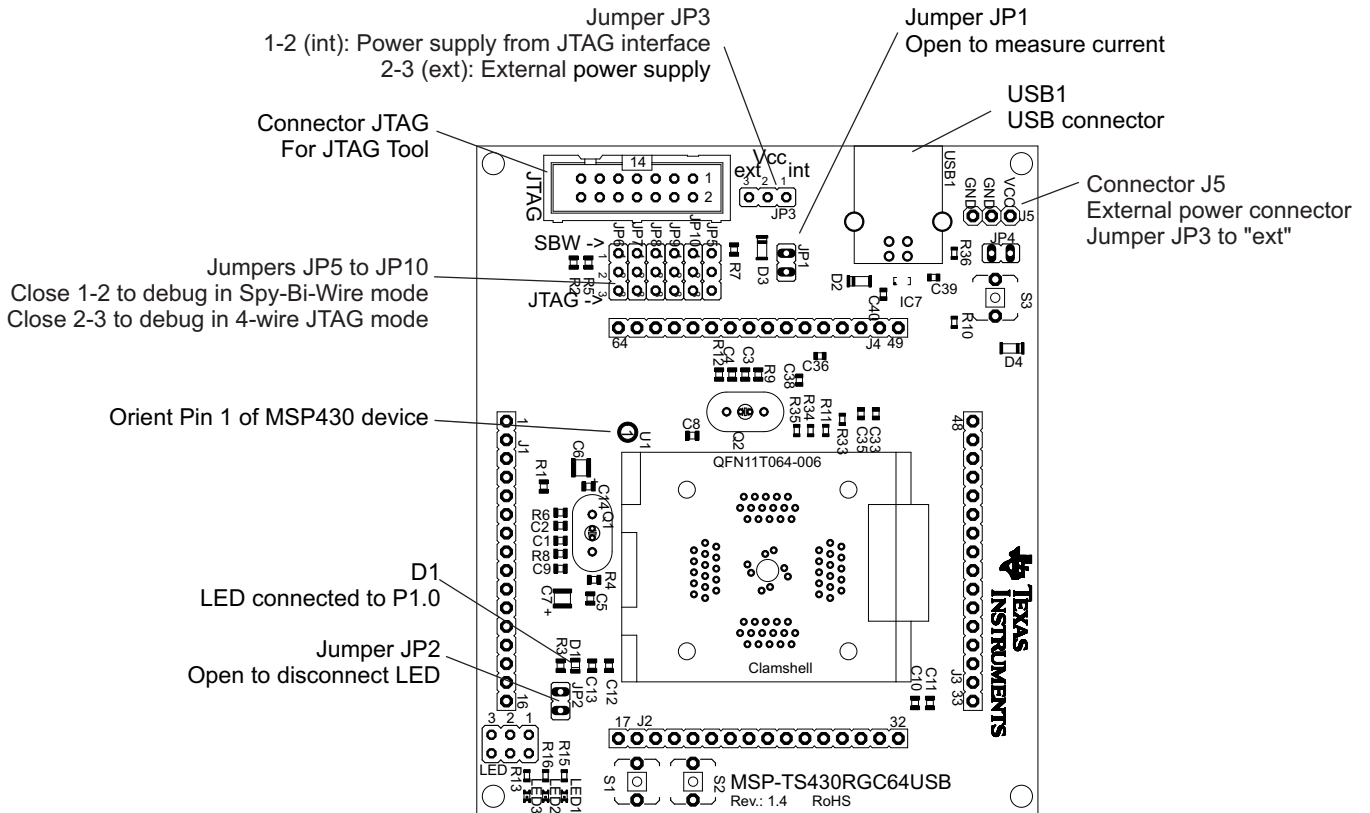

Figure B-51. MSP-TS430RGC64USB Target Socket Module, PCB

Table B-26. MSP-TS430RGC64USB Bill of Materials

Pos.	Ref Des	No. Per Board	Description	Digi-Key Part No.	Comment
1	C1, C2	0	12pF, SMD0805		DNP: C1, C2
1.1	C3, C4	2	47pF, SMD0805		
2	C6, C7	2	10uF, 6.3V, Tantal Size B	511-1463-2-ND	
3	C5, C11, C13, C14	4	100nF, SMD0805	311-1245-2-ND	
3.1	C10, C12	0	10uF, SMD0805		DNP: C10, C12
4	C8	1	2.2nF, SMD0805		
5	C9	1	470nF, SMD0805	478-1403-2-ND	
6	D1	1	green LED, SMD0805	P516TR-ND	
7	J1, J2, J3, J4	4	16-pin header, TH	SAM1029-16-ND SAM1213-16-ND	DNP: headers and receptacles enclosed with kit. Keep vias free of solder. : Header : Receptacle
8	J5	1	3-pin header, male, TH	SAM1035-03-ND	
9	JP5, JP6, JP7, JP8, JP9, JP10	6	3-pin header, male, TH	SAM1035-03-ND	place jumpers on pins 2-3
10	JP1, JP2, JP4	3	2-pin header, male, TH	SAM1035-02-ND	place jumper on header
11	JP3	1	3-pin header, male, TH	SAM1035-03-ND	place jumper on pins 1-2
12		10	Jumper	15-38-1024-ND	Place on: JP1, JP2, JP3, JP4, JP5, JP6, JP7, JP8, JP9, JP10
13	JTAG	1	14-pin connector, male, TH	HRP14H-ND	
14	Q1	0	Crystal	Q1: Micro Crystal MS1V-T1K 32.768kHz, C(Load) = 12.5pF	DNP: Q1 Keep vias free of solder
15	Q2	1	Crystal	Q2: 4MHz Buerklin: 78D134	
16	R3, R7	2	330 Ω, SMD0805	541-330ATR-ND	
17	R1, R2, R4, R6, R8, R9, R12	2	0 Ω, SMD0805	541-000ATR-ND	DNP: R4, R6, R8, R9, R12
18	R10	1	100 Ω, SMD0805	Buerklin: 07E500	
18	R11	1	1M Ω, SMD0805		
18	R5	1	47k Ω, SMD0805	541-47000ATR-ND	
19	U1	1	Socket: QFN11T064-006		Manuf.: Yamaichi
20	PCB	1	79 x 77 mm		2 layers
21	Rubber stand off	4		Buerklin: 20H1724	Apply to corners at bottom side
22	MSP430	2	MSP430F5509 RGC		DNP: enclosed with kit. Is supplied by TI
23	Insulating disk to Q2	1	Insulating disk to Q2	http://www.ettinger.de/Art_Detail.cfm?ART_ARTNUM=70.08.121	
27	C33	1	220n SMD0603	Buerklin: 53D2074	
28	C35	1	10p SMD0603	Buerklin: 56D102	
29	C36	1	10p SMD0603	Buerklin: 56D102	
30	C38	1	220n SMD0603	Buerklin: 53D2074	
31	C39	1	4u7 SMD0603	Buerklin: 53D2086	
32	C40	1	0.1u SMD0603	Buerklin: 53D2068	
33	D2, D3, D4	3	LL103A	Buerklin: 24S3406	
34	IC7	1	TPD4E004		Manu: TI
36	LED	0	JP3QE	SAM1032-03-ND	DNP

Table B-26. MSP-TS430RGC64USB Bill of Materials (continued)

Pos.	Ref Des	No. Per Board	Description	Digi-Key Part No.	Comment
37	LED1	0	LEDCHIPLED_0603	FARNELL: 852-9833	DNP
38	LED2	0	LEDCHIPLED_0603	FARNELL: 852-9868	DNP
39	LED3	0	LEDCHIPLED_0603	FARNELL: 852-9841	DNP
40	R13, R15, R16	0	470R	Buerklin: 07E564	DNP
41	R33	1	1k4 / 1k5	Buerklin: 07E612	
42	R34	1	27R	Buerklin: 07E444	
43	R35	1	27R	Buerklin: 07E444	
44	R36	1	33k	Buerklin: 07E740	
45	S1	0	PB	P12225STB-ND	DNP
46	S2	0	PB	P12225STB-ND	DNP
46	S3	1	PB	P12225STB-ND	
47	USB1	1	USB_RECEPTACLE	FARNELL: 117-7885	

B.26 MSP-TS430PN80

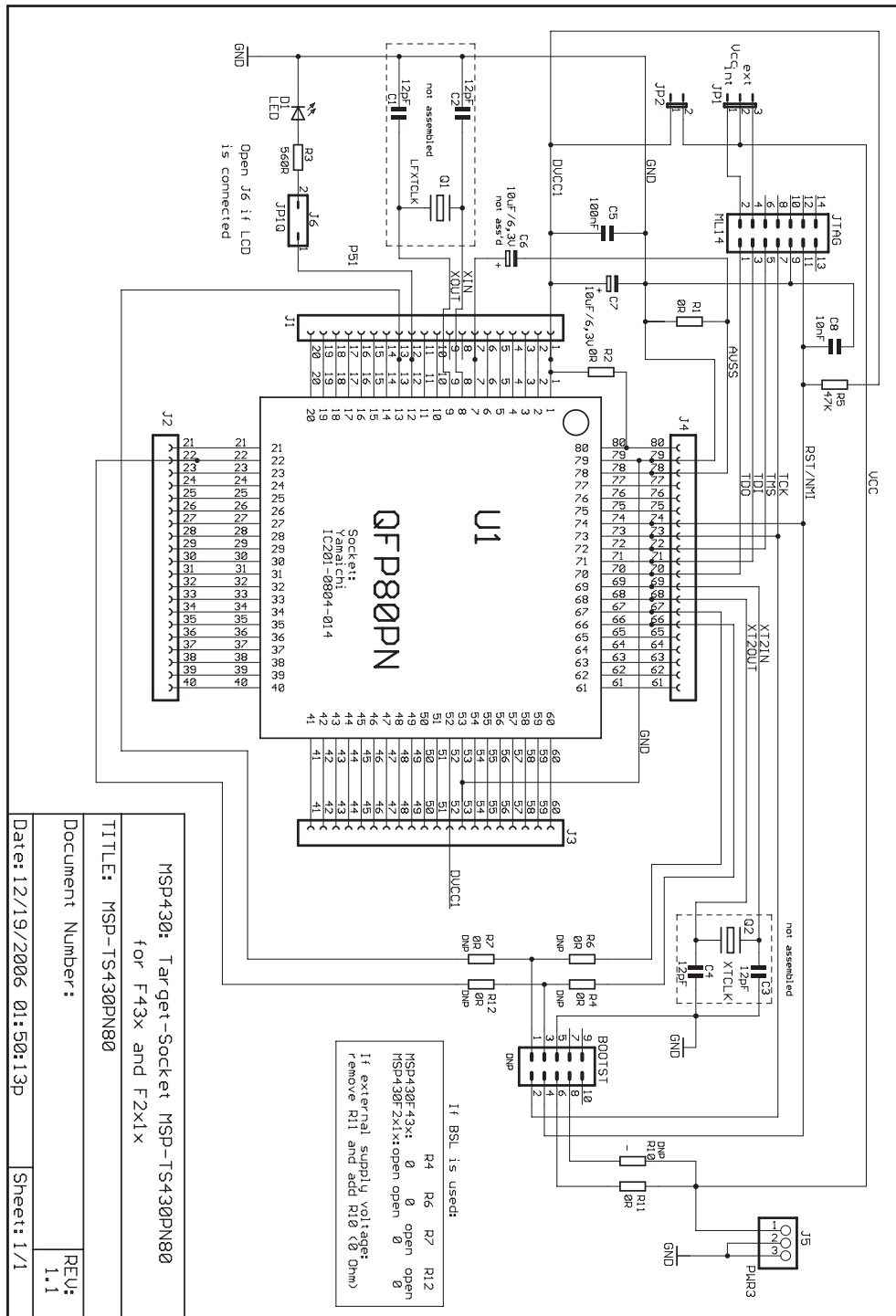

NOTE: For MSP430F47x and MSP430FG47x devices:
 Connect pins 7 and 10 (GND) externally to DV_{SS} (see data sheet).
 Connect load capacitance on V_{ref} pin 60 when SD16 is used (see data sheet).
 For use of BSL: connect pin 1 of BOOST to pin 58 of U1 and pin 3 of BOOST to pin 57 of U1.

Figure B-52. MSP-TS430PN80 Target Socket Module, Schematic

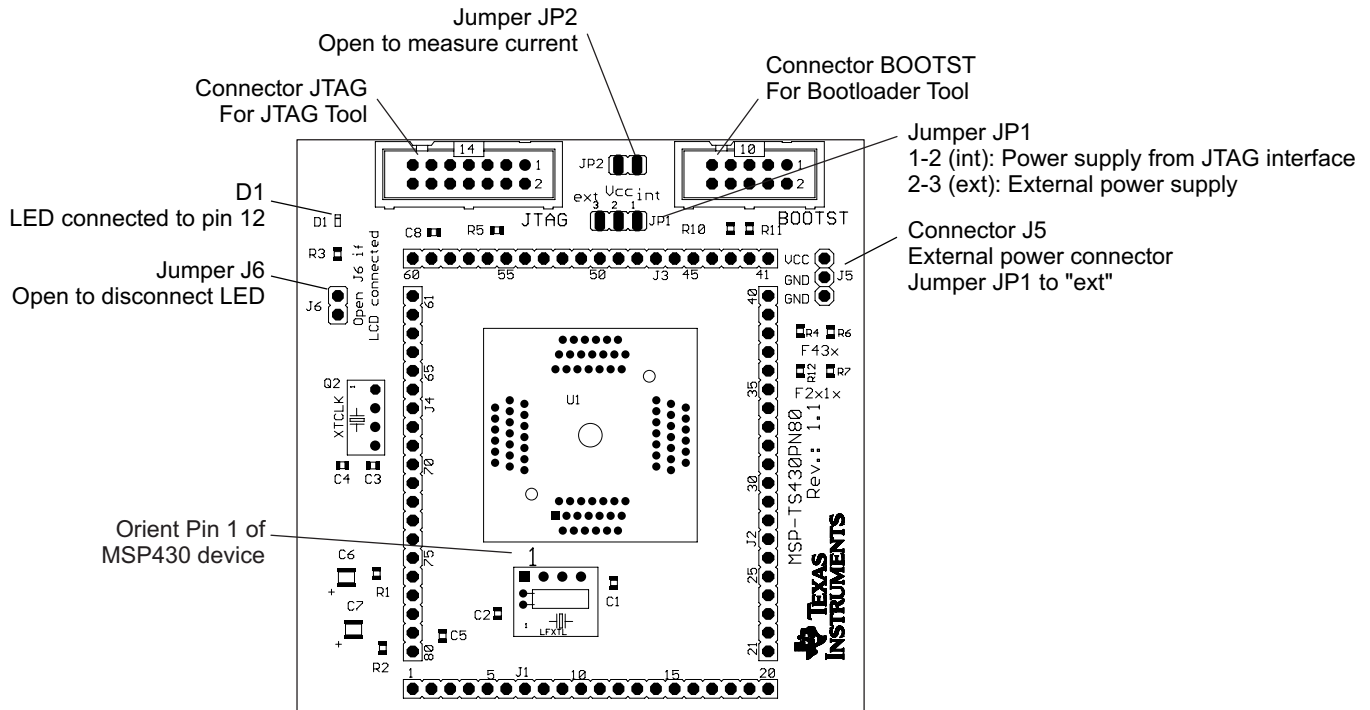

Figure B-53. MSP-TS430PN80 Target Socket Module, PCB

Table B-27. MSP-TS430PN80 Bill of Materials

Pos.	Ref Des	No. per Board	Description	Digi-Key Part No.	Comment
1	C1, C2	0	12pF, SMD0805		DNP: C1, C2
1.1	C3, C4	0	47pF, SMD0805		DNP: Only recommendation. Check your crystal spec.
2	C6, C7	1	10uF, 10V, Tantal Size B	511-1463-2-ND	
3	C5	1	100nF, SMD0805	478-3351-2-ND	
4	C8	1	10nF, SMD0805	478-1383-2-ND	
5	D1	1	green LED, SMD0603	475-1056-2-ND	
6	J1, J2, J3, J4	0	25-pin header, TH	SAM1029-20-ND SAM1213-20-ND	DNP: Headers and receptacles enclosed with kit. Keep vias free of solder. : Header : Receptacle
7	J5, JP1	2	3-pin header, male, TH	SAM1035-03-ND	
8	J6, JP2	2	2-pin header, male, TH	SAM1035-02-ND	Place jumper on header
9		3	Jumper	15-38-1024-ND	Place on: J6, JP2, JP1/Pos1-2
10	JTAG	1	14-pin connector, male, TH	HRP14H-ND	
11	BOOTST	0	10-pin connector, male, TH		DNP: Keep vias free of solder
12	Q1, Q2	0	Crystal	Q1: Micro Crystal MS1V-T1K 32.768kHz, C(Load) = 12.5pF	DNP: Keep vias free of solder
13	R3	1	560 Ω, SMD0805	541-560ATR-ND	
14	R1, R2, R4, R6, R7, R10, R11, R12	2	0 Ω, SMD0805	541-000ATR-ND	DNP: R4, R6, R7, R10, R11, R12
15	R5	1	47k Ω, SMD0805	541-47000ATR-ND	
16	U1	1	Socket: IC201-0804-014		Manuf.: Yamaichi
17	PCB	1	77 x 77 mm		2 layers
18	Adhesive Plastic feet	4	~6mm width, 2mm height	for example, 3M Bumpons Part No. SJ-5302	Apply to corners at bottom side
19	MSP430	2	MSP430FG439IPN		DNP: Enclosed with kit supplied by TI

B.27 MSP-TS430PN80A

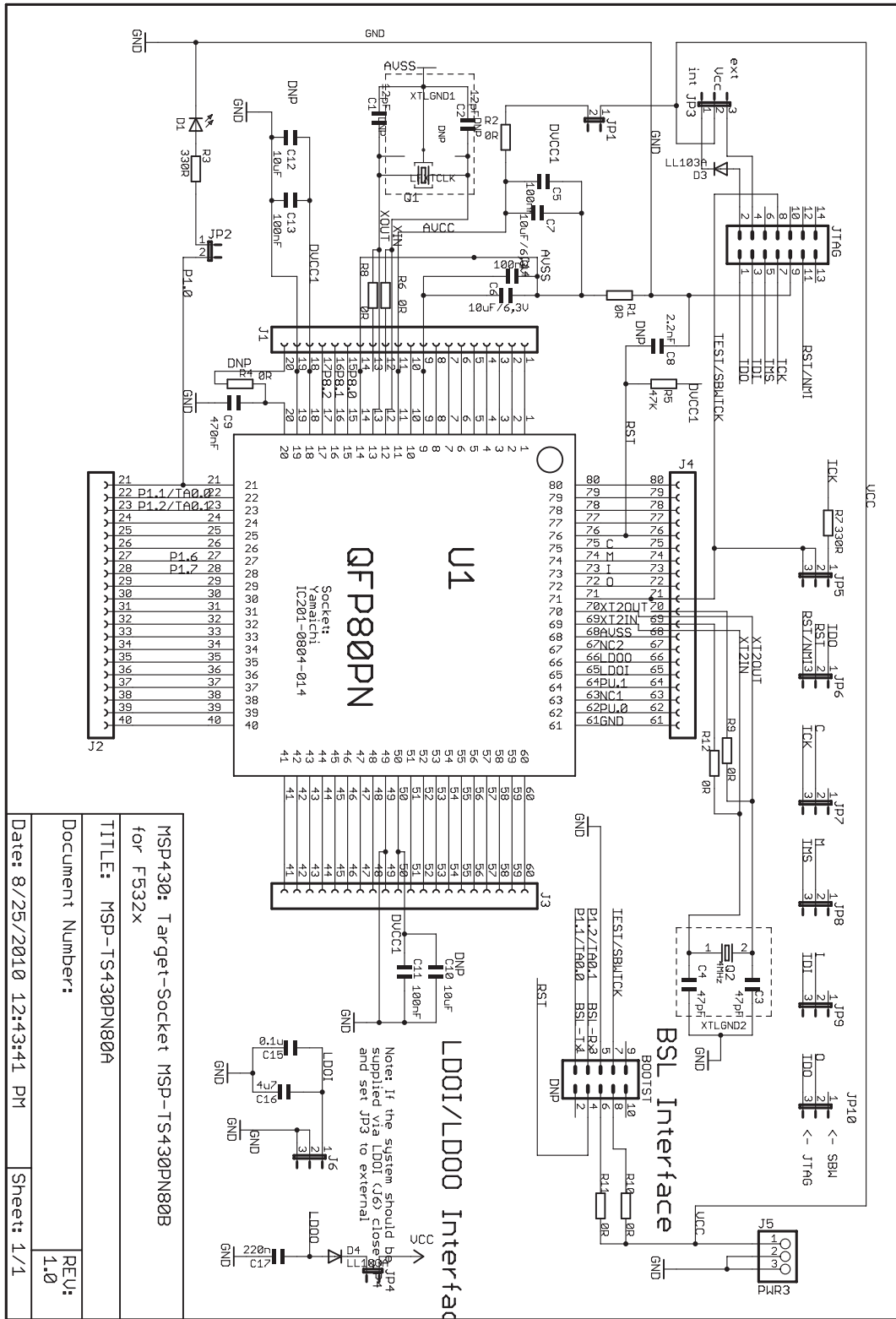

Figure B-54. MSP-TS430PN80A Target Socket Module, Schematic

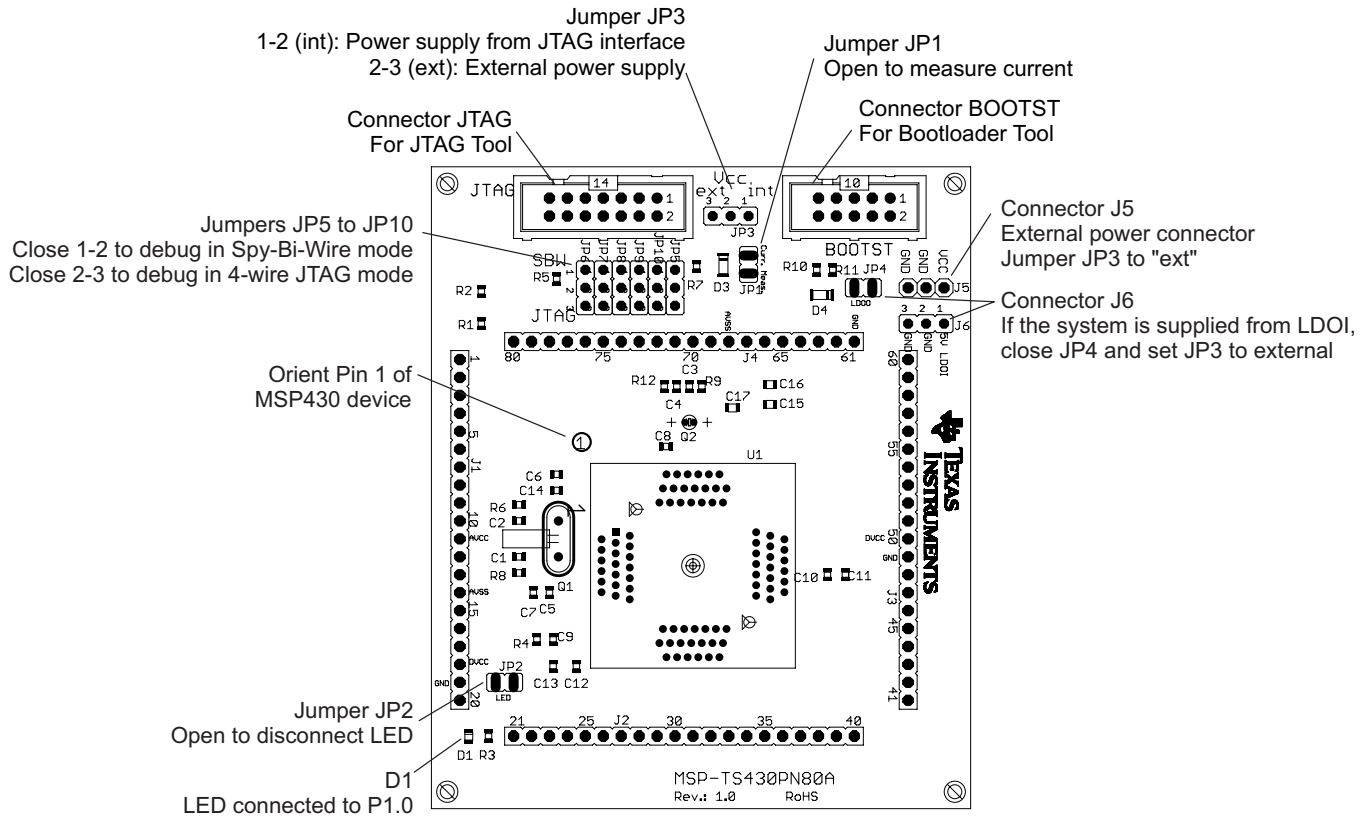

Figure B-55. MSP-TS430PN80A Target Socket Module, PCB

NOTE: For bootloader use, the BSL connector and only one of the resistors R10 or R11 must be populated. If the board is supplied internally, R11 (0 Ω) must be assembled. If the board is supplied externally, R10 (0 Ω) must be assembled, and R11 must be removed.

Table B-28. MSP-TS430PN80A Bill of Materials

Position	Ref Des	No. per Board	Description	Digi-Key Part No.	Comment
1	C1, C2	0	12pF, SMD0805		DNP
2	C3, C4	0	47pF, SMD0805		DNP
3	C6, C7, C10, C12	3	10uF, 6.3V, SMD0805		DNP C10
4	C5, C11, C13, C14, C15	5	100nF, SMD0805	311-1245-2-ND	
5	C8	1	2.2nF, SMD0805		
6	C9	1	470nF, SMD0805	478-1403-2-ND	
7	C16	1	4.7uF, SMD0805		
8	C17	1	220nF, SMD0805		
9	D1	1	green LED, SMD0805	P516TR-ND	
10	J1, J2, J3, J4	0	20-pin header, TH	SAM1029-20-ND (Header) SAM1213-20-ND (Receptacle)	DNP: Headers and receptacles enclosed with kit. Keep vias free of solder:
11	J5, J6	2	3-pin header, male, TH		
12	JP3, JP5, JP6, JP7, JP8, JP9, JP10	7	3-pin header, male, TH	SAM1035-03-ND	place jumpers on pins 2-3 on JP5, JP6, JP7, JP8, JP9, JP10 place jumpers on pins 1-2 on JP3,
13	JP1, JP2, JP4	3	2-pin header, male, TH	SAM1035-02-ND	Place jumper on header
14		10	Jumper	15-38-1024-ND	See Pos. 12 and Pos. 13
15	JTAG	1	14-pin connector, male, TH	HRP14H-ND	
16	BOOTST	0	10-pin connector, male, TH		"DNP Keep vias free of solder"
17	Q1	0	Crystal	Micro Crystal MS3V-T1R 32.768kHz, C(Load) = 12.5pF	DNP: Q1 Keep vias free of solder
18	Q2	0	Crystal	Q2: 4MHz Buerklin: 78D134	DNP: Q2 Keep vias free of solder
19	Insulating disk to Q2	0	Insulating disk to Q2	http://www.ettinger.de/Art_Detail.cfm?ART_ARTNUM=70.08.121	
20	D3,D4	2	LL103A	Buerklin: 24S3406	
21	R3, R7	2	330 Ω, SMD0805	541-330ATR-ND	
22	R1, R2, R4, R6, R8, R9,R10, R11, R12	3	0 Ohm, SMD0805	541-000ATR-ND	DNP: R6, R8, R9, R10, R11,R12
23	R5	1	47k Ω, SMD0805	541-47000ATR-ND	
24	U1	1	Socket:IC201-0804-014		Manuf.: Yamaichi
25	PCB	1	77 x 91 mm		2 layers
26	Adhesive plastic feet	4	Approximately 6mm width, 2mm height	for example, 3M Bumpons Part No. SJ-5302	Apply to corners at bottom side
27	MSP430	2	MSP430F5329IPN		DNP: enclosed with kit, supplied by TI

B.28 MSP-TS430PN80USB

Due to the use of diodes in the power chain, the voltage on the MSP430F5xx device is approximately 0.3 V lower than is set by the debugging tool. Set the voltage in the IDE to 0.3 V higher than desired; for example, to run the MCU at 3.0 V, set it to 3.3 V.

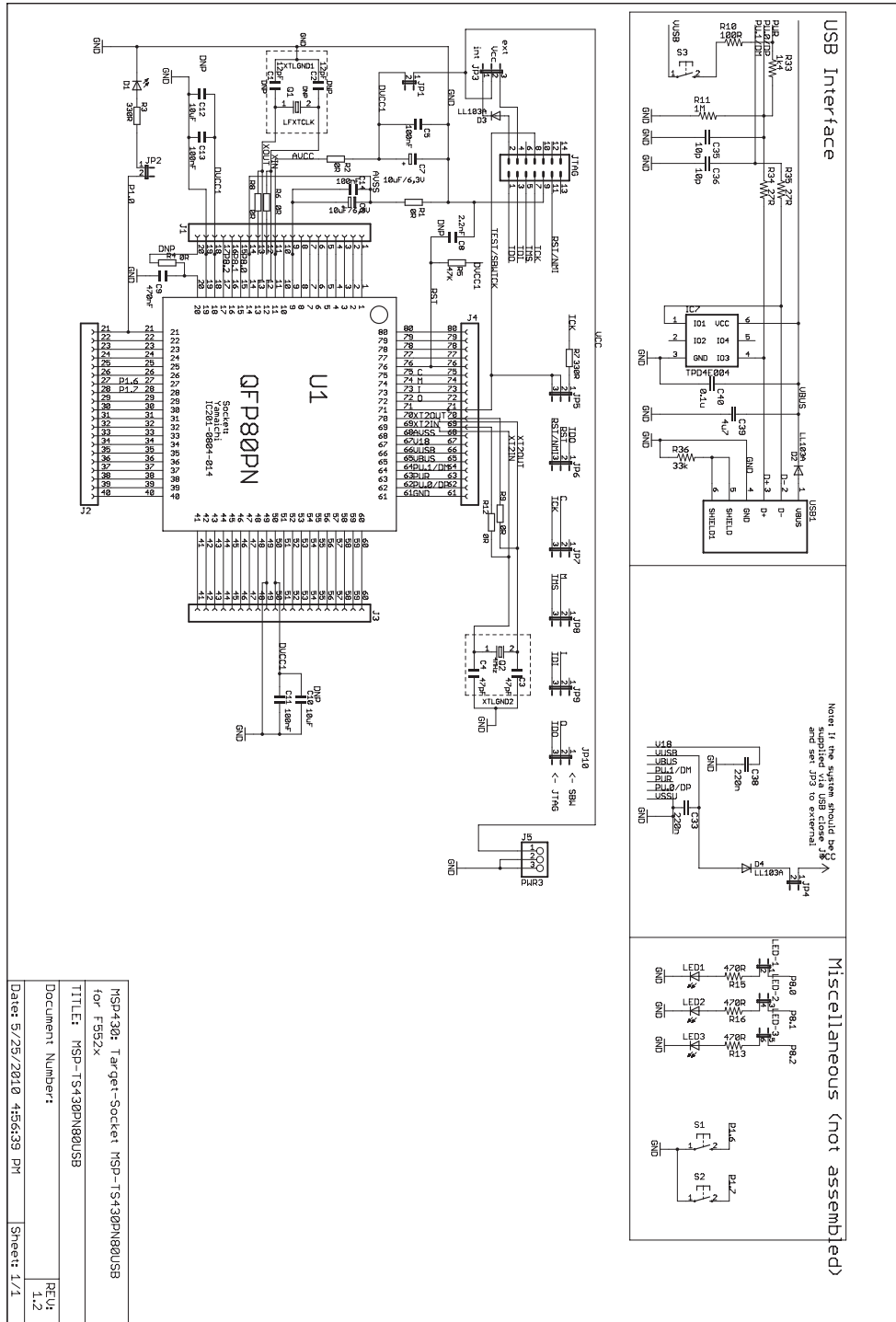

NOTE: R11 should be populated.

Figure B-56. MSP-TS430PN80USB Target Socket Module, Schematic

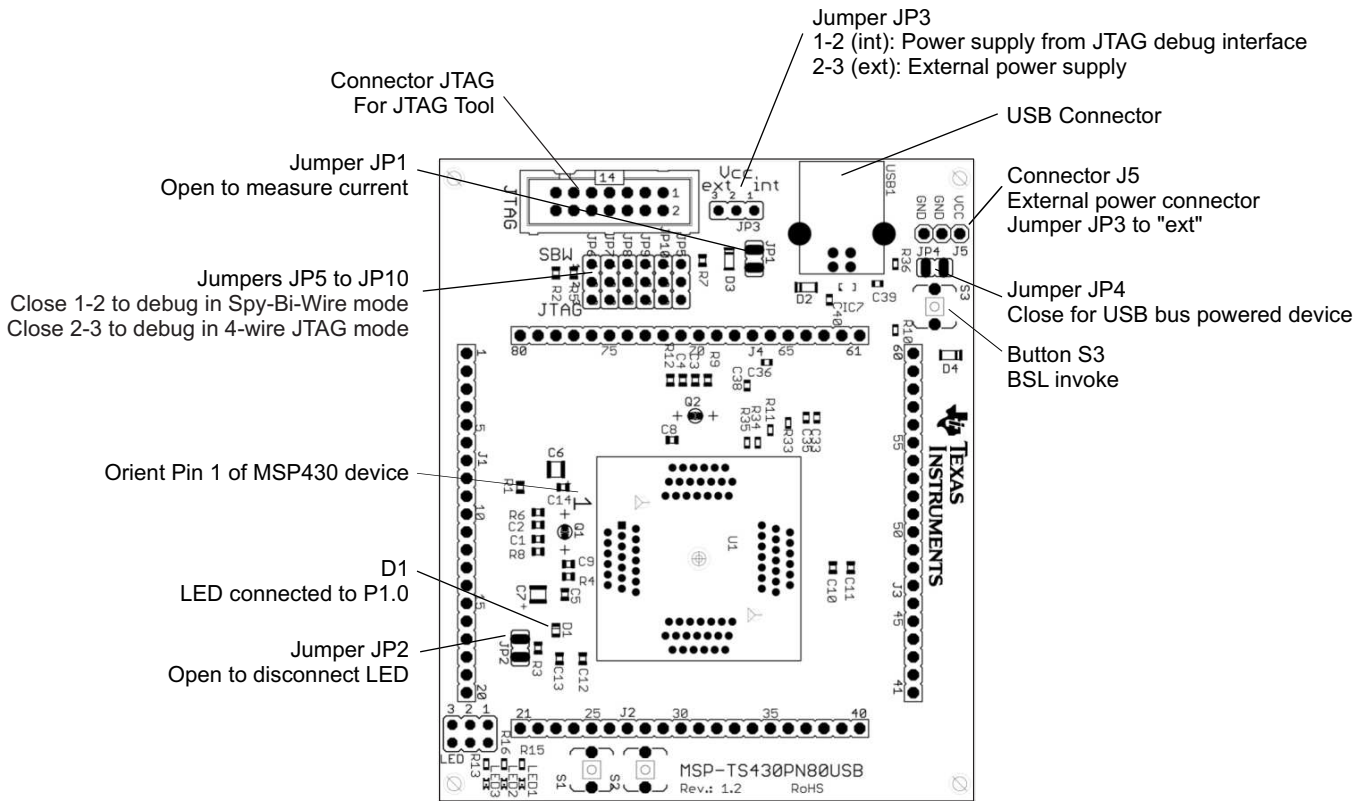

Figure B-57. MSP-TS430PN80USB Target Socket Module, PCB

Table B-29. MSP-TS430PN80USB Bill of Materials

Pos.	Ref Des	No. per Board	Description	Digi-Key Part No.	Comment
1	C1, C2	0	12pF, SMD0805		DNP: C1, C2
1.1	C3, C4	2	47pF, SMD0805		
2	C6, C7	2	10uF, 6.3V, Tantal Size B	511-1463-2-ND	
3	C5, C11, C13, C14	4	100nF, SMD0805	311-1245-2-ND	
3.1	C10, C12	0	10uF, SMD0805	311-1245-2-ND	DNP: C10, C12
4	C8	1	2.2nF, SMD0805		
5	C9	1	470nF, SMD0805	478-1403-2-ND	
6	D1	1	green LED, SMD0805	P516TR-ND	
7	J1, J2, J3, J4	4	20-pin header, TH	SAM1029-20-ND	DNP: headers and receptacles enclosed with kit. Keep vias free of solder.
7.1		4	20-pin header, TH	SAM1213-20-ND	DNP: headers and receptacles enclosed with kit. Keep vias free of solder. : Header : Receptacle
8	J5	1	3-pin header, male, TH	SAM1035-03-ND	
9	JP5, JP6, JP7, JP8, JP9, JP10	6	3-pin header, male, TH	SAM1035-03-ND	Place jumpers on pins 2-3
10	JP1, JP2	2	2-pin header, male, TH	SAM1035-02-ND	Place jumper on header
	JP4	1		SAM1035-02-ND	Place jumper only on one pin
11	JP3	1	3-pin header, male, TH	SAM1035-03-ND	Place jumper on pins 1-2
12		10	Jumper	15-38-1024-ND	Place on: JP1, JP2, JP3, JP4, JP5, JP6, JP7, JP8, JP9, JP10
13	JTAG	1	14-pin connector, male, TH	HRP14H-ND	
14	Q1	0	Crystal	Micro Crystal MS1V-T1K 32.768kHz, C(Load) = 12.5pF	DNP: Q1 Keep vias free of solder
15	Q2	1	Crystal	"Q2: 4MHzBuerklin: 78D134"	
16	R3, R7	2	330 Ω, SMD0805	541-330ATR-ND	
17	R1, R2, R4, R6, R8, R9, R12	2	0 Ω, SMD0805	541-000ATR-ND	DNP: R4, R6, R8, R9, R12
18	R10	1	100 Ω, SMD0805	Buerklin: 07E500	
18	R11	0	1M Ω, SMD0805		DNP
18	R5	1	47k Ω, SMD0805	541-47000ATR-ND	
19	U1	1	Socket:IC201-0804-014		Manuf.: Yamaichi
20	PCB	1	79 x 77 mm		2 layers
21	Rubber standoff	4		Buerklin: 20H1724	Apply to corners at bottom side
22	MSP430	2	MSP430F5529		DNP: Enclosed with kit supplied by TI
23	Insulating disk to Q2	1	Insulating disk to Q2	http://www.ettinger.de/Art_De tail.cfm?ART_ARTNUM=70.08.121	
27	C33	1	220n	Buerklin: 53D2074	
28	C35	1	10p	Buerklin: 56D102	
29	C36	1	10p	Buerklin: 56D102	
30	C38	1	220n	Buerklin: 53D2074	

Table B-29. MSP-TS430PN80USB Bill of Materials (continued)

Pos.	Ref Des	No. per Board	Description	Digi-Key Part No.	Comment
31	C39	1	4u7	Buerklin: 53D2086	
32	C40	1	0.1u	Buerklin: 53D2068	
33	D2, D3, D4	3	LL103A	Buerklin: 24S3406	
34	IC7	1	TPD4E004		Manu: TI
36	LED	0	JP3QE	SAM1032-03-ND	DNP
37	LED1	0	LEDCHIPLD_0603	FARNELL: 852-9833	DNP
38	LED2	0	LEDCHIPLD_0603	FARNELL: 852-9868	DNP
39	LED3	0	LEDCHIPLD_0603	FARNELL: 852-9841	DNP
40	R13, R15, R16	0	470R	Buerklin: 07E564	DNP
41	R33	1	1k4	Buerklin: 07E612	
42	R34	1	27R	Buerklin: 07E444	
43	R35	1	27R	Buerklin: 07E444	
44	R36	1	33k	Buerklin: 07E740	
45	S1	0	PB	P12225STB-ND	DNP
46	S2	0	PB	P12225STB-ND	DNP
46	S3	1	PB	P12225STB-ND	
47	USB1	1	USB_RECEPTACLE	FARNELL: 117-7885	

B.29 MSP-TS430PZ100

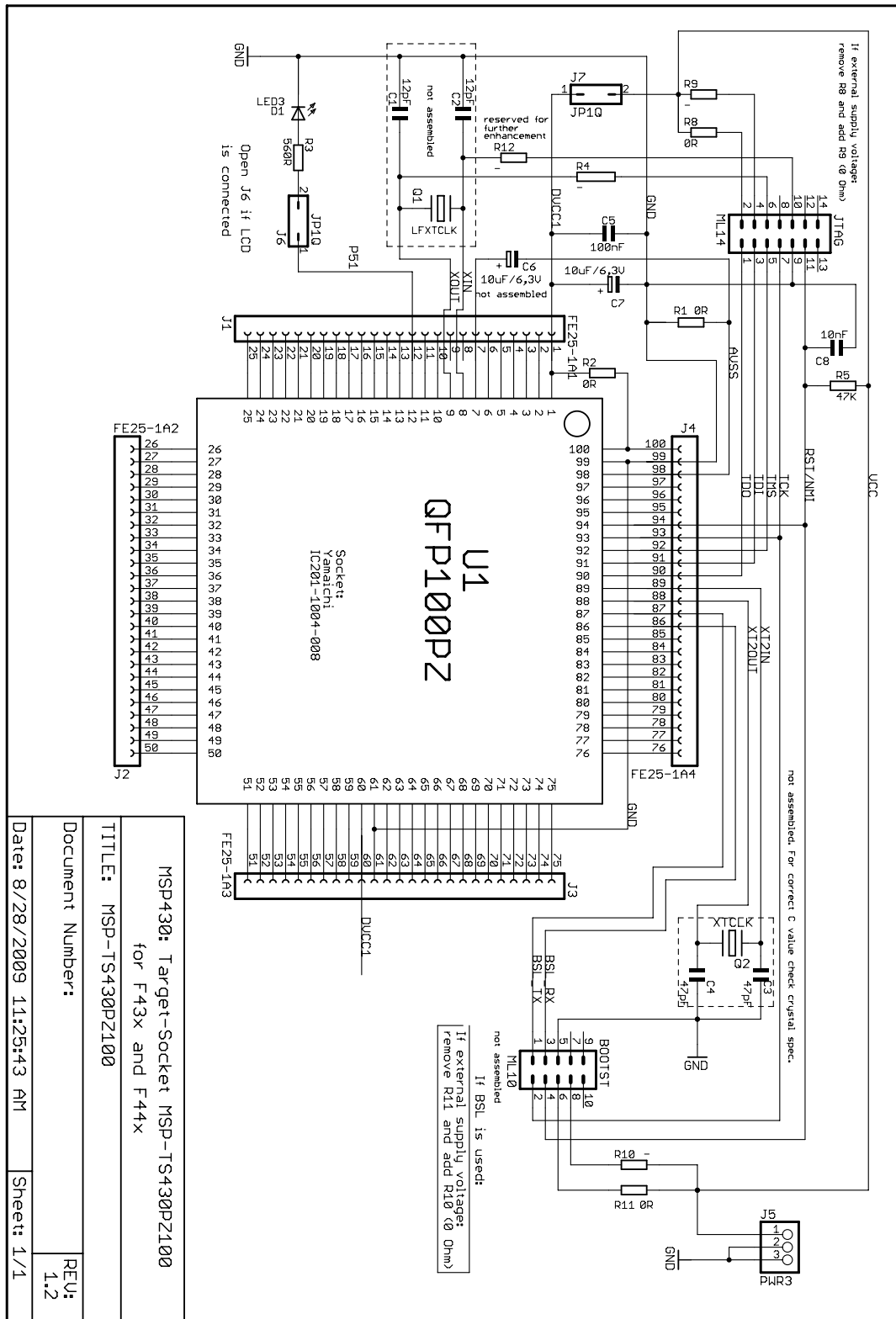

NOTE: Connections between the JTAG header and pins XOUT and XIN are no longer required and should not be made.

Figure B-58. MSP-TS430PZ100 Target Socket Module, Schematic

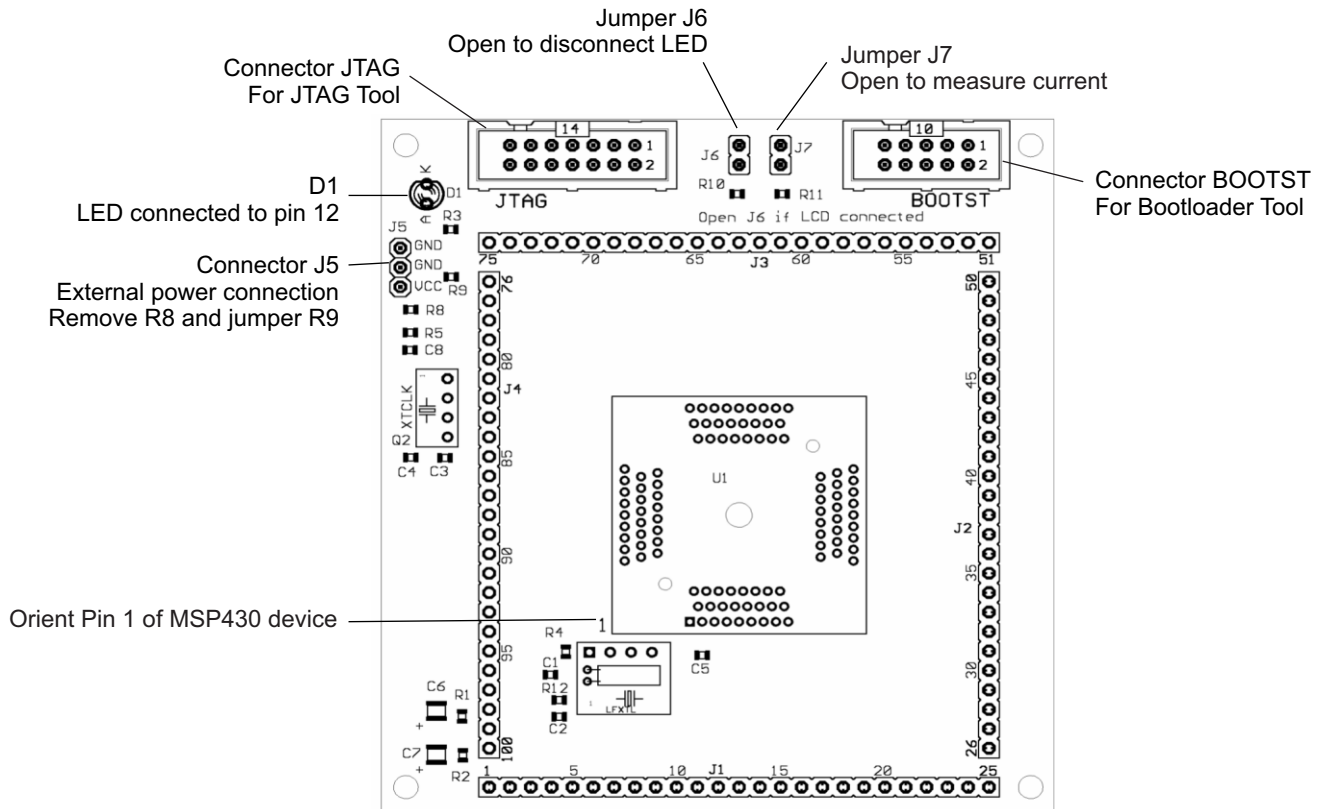

Figure B-59. MSP-TS430PZ100 Target Socket Module, PCB

Table B-30. MSP-TS430PZ100 Bill of Materials

Pos.	Ref Des	No. per Board	Description	Digi-Key Part No.	Comment
1	C1, C2	0	12pF, SMD0805		DNP
1b	C3, C4	0	47pF, SMD0805		DNP: Only recommendation. Check your crystal spec.
2	C6, C7	1	10uF, 10V, Tantal Size B	511-1463-2-ND	DNP: C6
3	C5	1	100nF, SMD0805	478-3351-2-ND	
4	C8	1	10nF, SMD0805	478-1383-2-ND	
5	C9	1	470nF, SMD0805	478-1403-2-ND	
6	D1	1	yellow LED, TH, 3mm, T1	511-1251-ND	
7	J1, J2, J3, J4	0	25-pin header, TH	SAM1029-25-ND SAM1213-25-ND	DNP: Headers and receptacles enclosed with kit. Keep vias free of solder. : Header : Receptacle
8	J5	1	3-pin header, male, TH	SAM1035-03-ND	
9	J6, J7	2	2-pin header, male, TH	SAM1035-02-ND	place jumper on header
10		2	Jumper	15-38-1024-ND	Place on: J6, J7
11	JTAG	1	14-pin connector, male, TH	HRP14H-ND	
12	BOOTST	0	10-pin connector, male, TH		DNP: Keep vias free of solder
13	Q1, Q2	0	Crystal	Q1: Micro Crystal MS1V-T1K 32.768kHz, C(Load) = 12.5pF	DNP: Keep vias free of solder
14	R3	1	330 Ω , SMD0805	541-330ATR-ND	
15	R1, R2, R4, R8, R9, R10, R11, R12	3	0 Ω , SMD0805	541-000ATR-ND	DNP: R4, R9, R10, R12
16	R5	1	47k Ω , SMD0805	541-47000ATR-ND	
17	U1	1	Socket: IC201-1004-008 or IC357-1004-53N		Manuf.: Yamaichi
18	PCB	1	82 x 90 mm		2 layers
19	Adhesive Plastic feet	4	~6mm width, 2mm height	for example, 3M Bumpons Part No. SJ-5302	Apply to corners at bottom side
20	MSP430	2	MSP430FG4619IPZ		DNP: enclosed with kit supplied by TI

B.30 MSP-TS430PZ100A

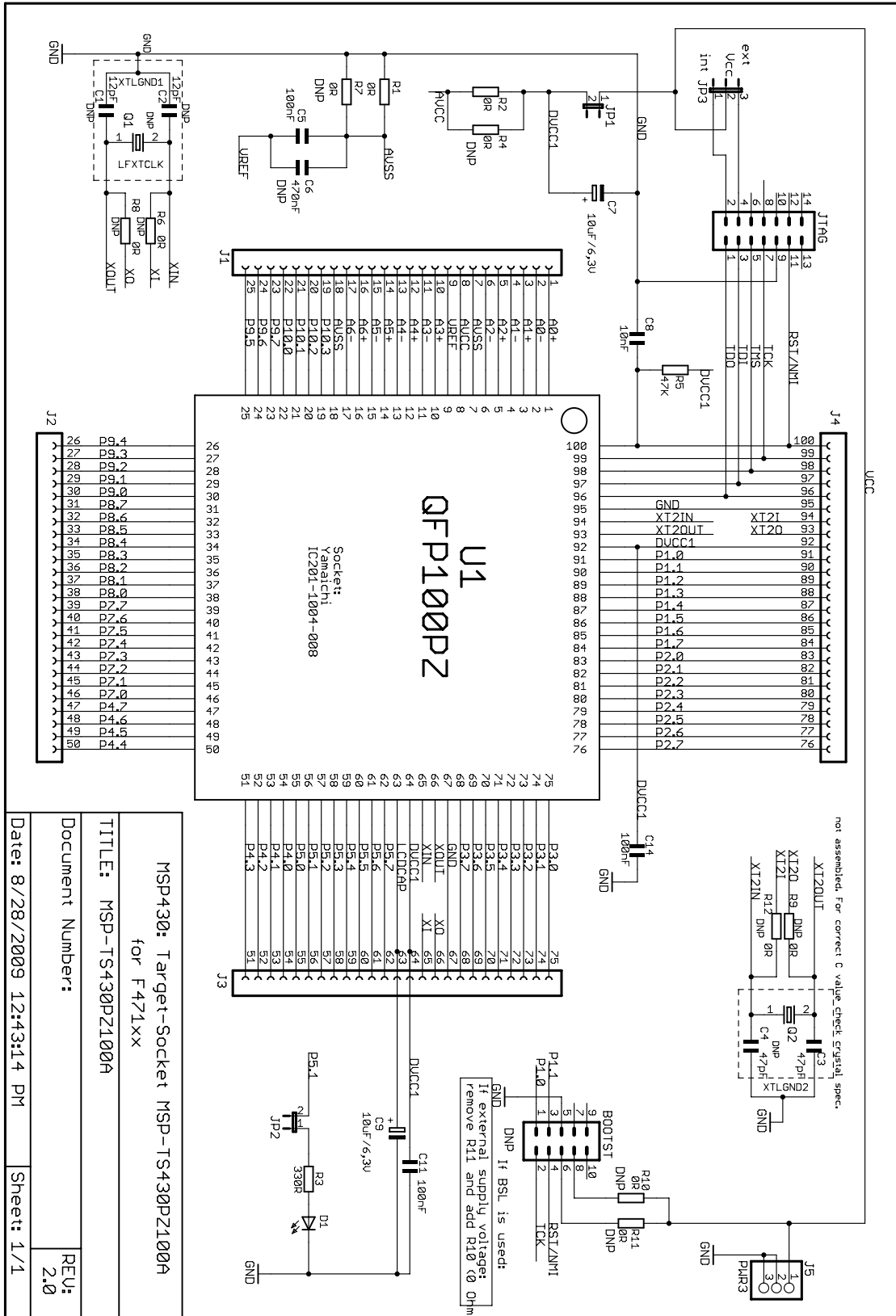

Figure B-60. MSP-TS430PZ100A Target Socket Module, Schematic

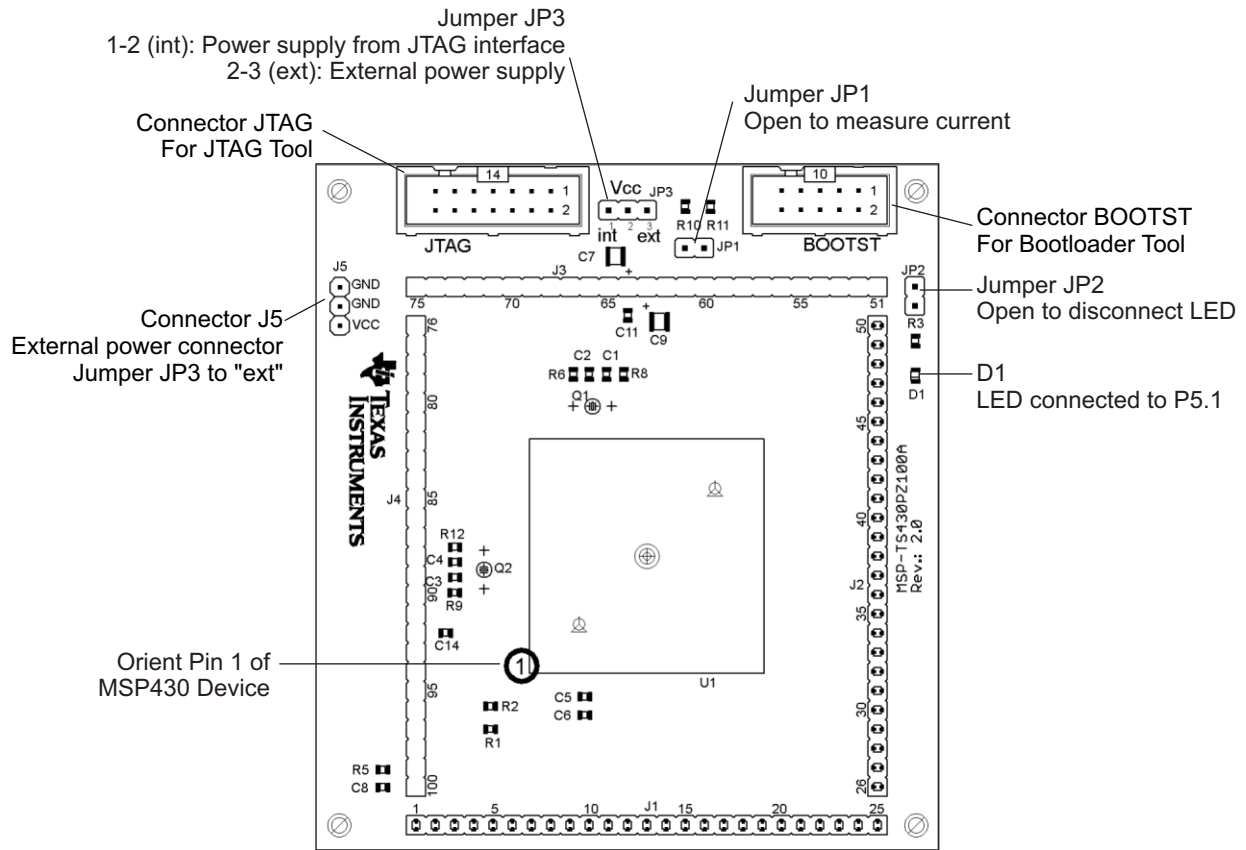

Figure B-61. MSP-TS430PZ100A Target Socket Module, PCB

Table B-31. MSP-TS430PZ100A Bill of Materials

Pos.	Ref Des	No. per Board	Description	Digi-Key Part No.	Comment
1	C1, C2	0	12pF, SMD0805		DNP
1b	C3, C4	0	47pF, SMD0805		DNP: Only recommendation. Check your crystal spec.
2	C7, C9	2	10uF, 10V, Tantal Size B	511-1463-2-ND	
3	C5, C11, C14	3	100nF, SMD0805	311-1245-2-ND	
4	C8	1	10nF, SMD0805	478-1358-1-ND	
5	C6	0	470nF, SMD0805	478-1403-2-ND	DNP
6	D1	1	green LED, SMD0805	67-1553-1-ND	
7	J1, J2, J3, J4	0	25-pin header, TH	SAM1029-25-ND SAM1213-25-ND	DNP: Headers and receptacles enclosed with kit. Keep vias free of solder. : Header : Receptacle
8	J5	1	3-pin header, male, TH	SAM1035-03-ND	
10	JP1, JP2	2	2-pin header, male, TH	SAM1035-02-ND	pPlace jumper on header
11	JP3	1	3-pin header, male, TH	SAM1035-03-ND	Place jumper on pins 1-2
12		3	Jumper	15-38-1024-ND	Place on: JP1, JP2, JP3
13	JTAG	1	14-pin connector, male, TH	HRP14H-ND	
14	BOOTST	0	10-pin connector, male, TH		DNP: Keep vias free of solder
15	Q1, Q2	0	Crystal	Q1: Micro Crystal MS1V-T1K 32.768kHz, C(Load) = 12.5pF	DNP: Keep vias free of solder
16	R3	1	330 Ω , SMD0805	541-330ATR-ND	
17	R1, R2, R4, R6, R7, R8, R9, R10, R11, R12	2	0 Ω , SMD0805	541-000ATR-ND	DNP: R4, R6, R7, R8, R9, R10, R11, R12
18	R5	1	47k Ω , SMD0805	541-47000ATR-ND	
19	U1	1	Socket: IC357-1004-53N		Manuf.: Yamaichi
20	PCB	1	90 x 82 mm		4 layers
21	Rubber standoff	4		Select appropriate	Apply to corners at bottom side
22	MSP430	2	MSP430F47197IPZ		DNP: Enclosed with kit supplied by TI

B.31 MSP-TS430PZ100B

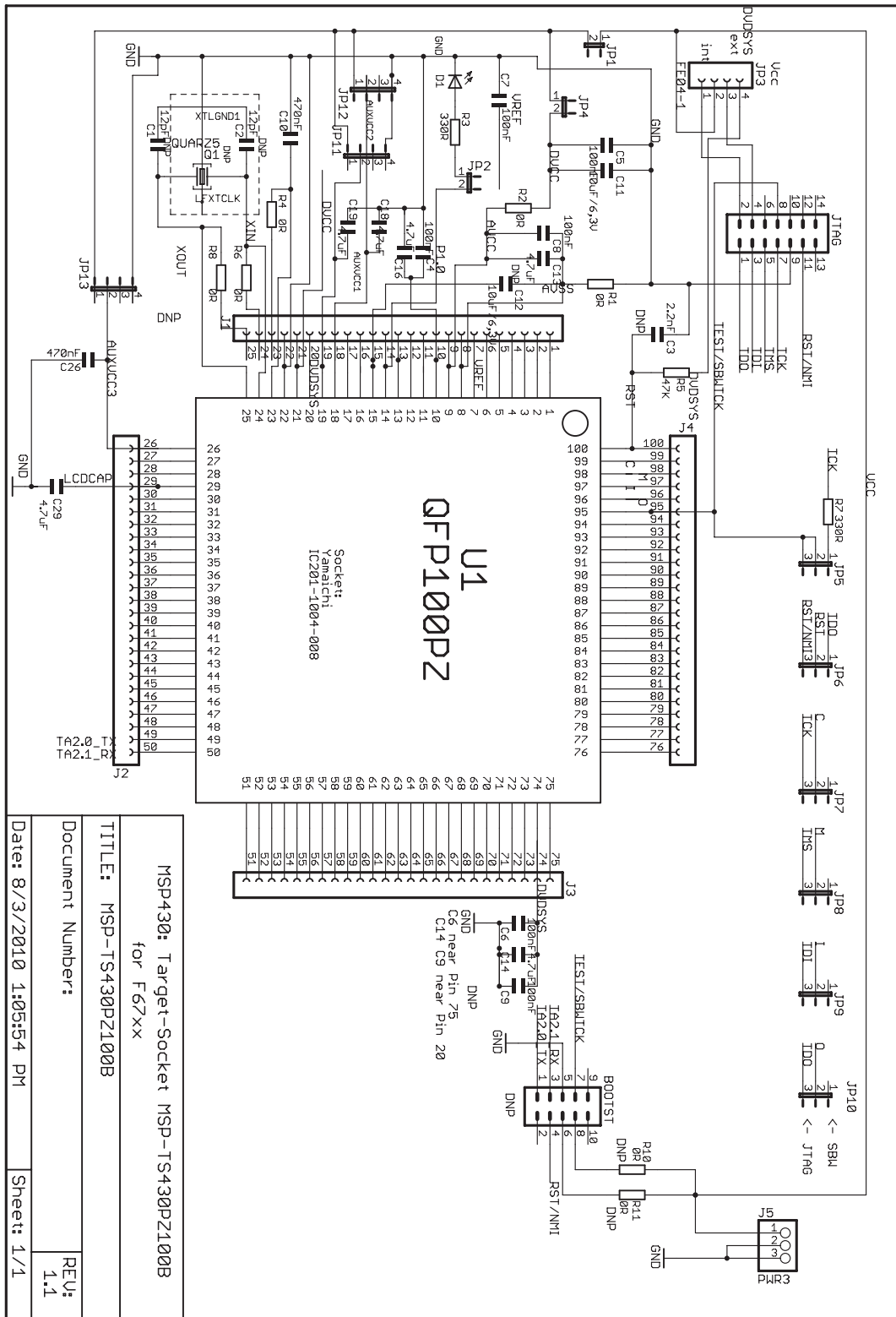

Figure B-62. MSP-TS430PZ100B Target Socket Module, Schematic

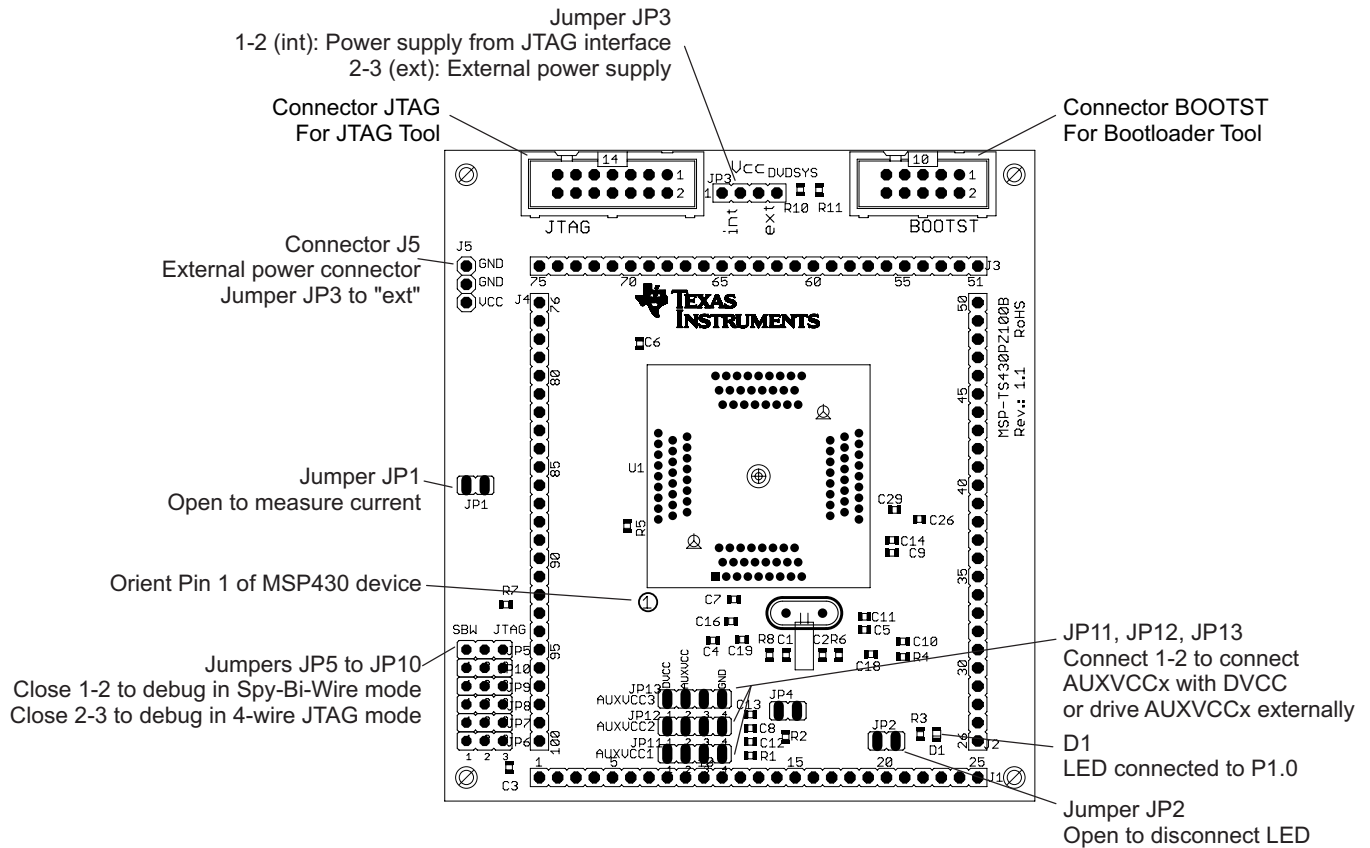

Figure B-63. MSP-TS430PZ100B Target Socket Module, PCB

NOTE: For bootloader use, the BSL connector and only one of the resistors R10 or R11 must be populated. If the board is supplied internally, R11 (0 Ω) must be assembled. If the board is supplied externally, R10 (0 Ω) must be assembled, and R11 must be removed.

Table B-32. MSP-TS430PZ100B Bill of Materials

Position	Ref Des	No. per Board	Description	Digi-Key Part No.	Comment
1	C1, C2	0	12pF, SMD0805		DNP
2	C4, C5, C6, C7, C8, C9	6	100nF, SMD0805	311-1245-2-ND	
3	C10, C26	2	470 nF, SMD0805	478-1403-2-ND	
4	C11, C12	1	10 uF / 6.3 V SMD0805		C12 DNP
5	C13, C14, C16, C18, C19, C29	6	4.7 uF SMD0805		
6	D1	1	green LED, SMD0805	P516TR-ND	
7	J1, J2, J3, J4	0	25-pin header, TH	SAM1029-25-ND (Header) SAM1213-25-ND (Receptacle)	DNP: Headers and receptacles enclosed with kit. Keep vias free of solder:
8	J5	1	3-pin header, male, TH		
9	JP3, JP5, JP6, JP7, JP8, JP9, JP10	7	3-pin header, male, TH	SAM1035-03-ND	place jumpers on pins 2-3 on JP5, JP6, JP7, JP8, JP9, JP10 place jumpers on pins 1-2 on JP3,
10	JP1, JP2, JP4	3	2-pin header, male, TH	SAM1035-02-ND	Place jumper on header
11	JP11, JP12, JP13	3	4-pin header, male, TH		place jumper on header 1-2
12		13	Jumper	15-38-1024-ND	See Pos. 9 and Pos. 10 and Pos. 11
15	JTAG	1	14-pin connector, male, TH	HRP14H-ND	
16	BOOTST	0	10-pin connector, male, TH		"DNP Keep vias free of solder"
17	Q1	0	Crystal		DNP: Q1 Keep vias free of solder
21	R3, R7	2	330 Ω , SMD0805	541-330ATR-ND	
22	R1, R2, R4, R6, R8, R10, R11	2	0 Ohm, SMD0805	541-000ATR-ND	DNP: R4, R6, R8, R10, R11
23	R5	1	47k Ω , SMD0805	541-47000ATR-ND	
24	U1	1	Socket: IC357-1004-53N		Manuf.: Yamaichi
25	PCB	1	90 x 82 mm		2 layers
26	Adhesive plastic feet	4	Approximately 6mm width, 2mm height	for example, 3M Bumpons Part No. SJ-5302	Apply to corners at bottom side
27	MSP430	2	MSP430F6733IPZ		DNP: enclosed with kit, supplied by TI

B.32 MSP-TS430PZ100C

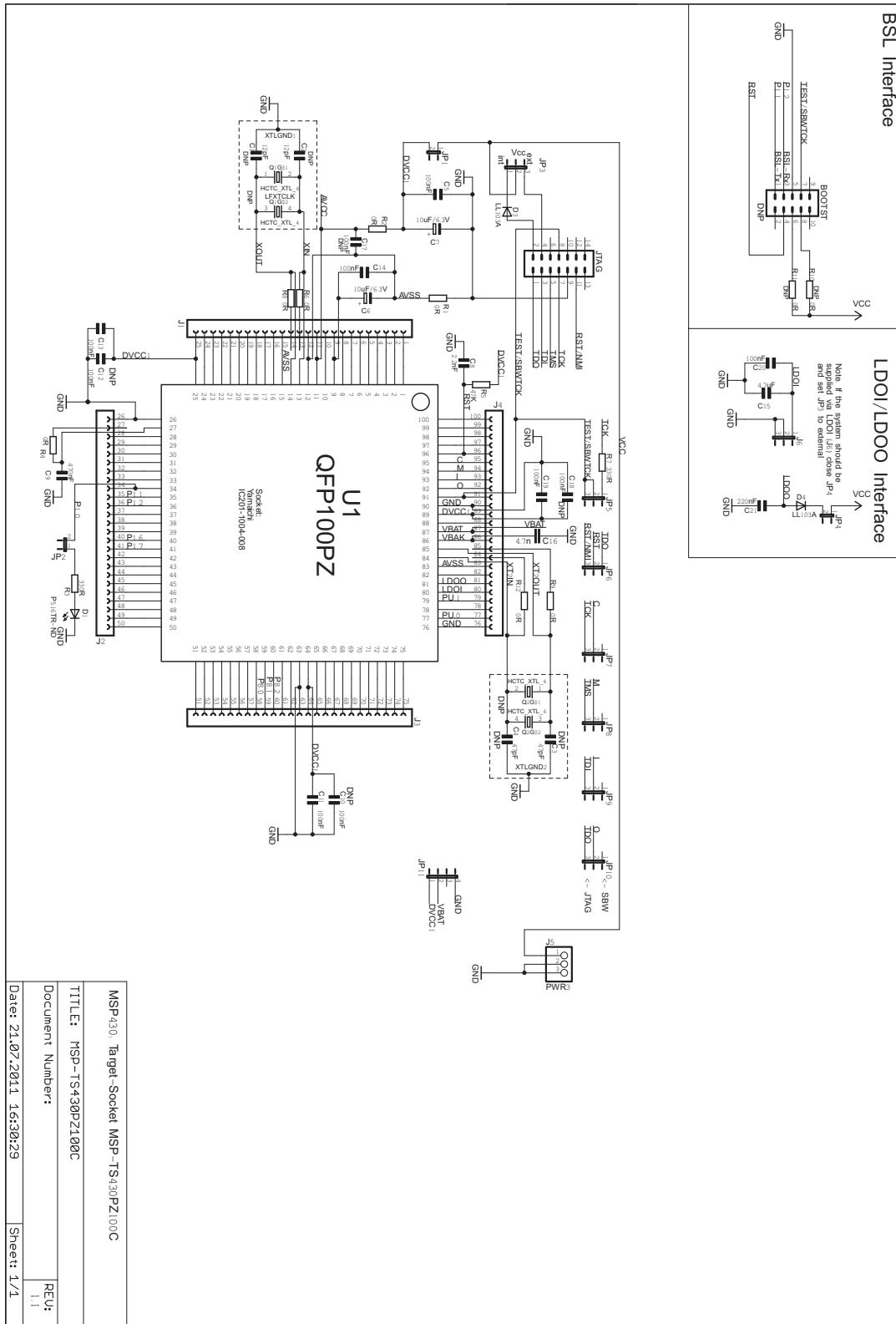

Figure B-64. MSP-TS430PZ100C Target Socket Module, Schematic

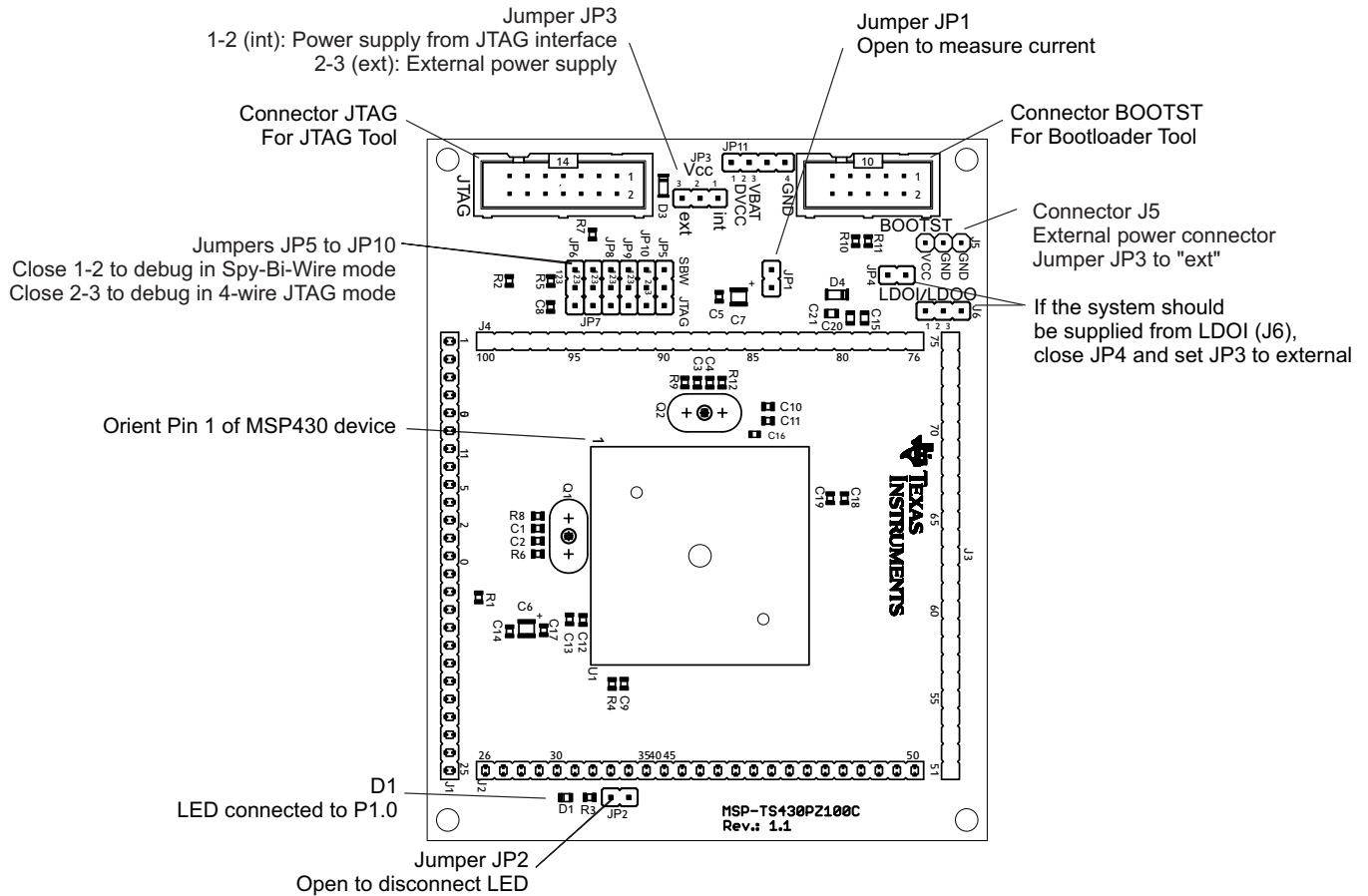

Figure B-65. MSP-TS430PZ100C Target Socket Module, PCB

NOTE: For bootloader use, the BSL connector and only one of the resistors R10 or R11 must be populated. If the board is supplied internally, R11 (0 Ω) must be assembled. If the board is supplied externally, R10 (0 Ω) must be assembled, and R11 must be removed.

Table B-33. MSP-TS430PZ100C Bill of Materials

Pos.	Ref Des	Number Per Board	Description	Digi-Key Part No.	Comment
1	C1, C2	0	12pF, SMD0805		DNP: C1, C2
1.1	C3, C4	2	47pF, SMD0805		DNP: C3, C4
2	C6, C7	2	10uF, 6.3V, Tantal Size B	511-1463-2-ND	
3	C5, C11, C13, C14, C19, C20	6	100nF, SMD0805	311-1245-2-ND	
3.1	C10, C12, C18,17	0	100nF, SMD0805	311-1245-2-ND	DNP: C10, C12,C18, C17
4	C8	1	2.2nF, SMD0805	Buerklin 53 D 292	
5	C9	1	470nF, SMD0805	478-1403-2-ND	
6	D1	1	green LED, SMD0805	P516TR-ND	
7	J1, J2, J3, J4	4	25-pin header, TH	SAM1029-25-ND	DNP: headers and receptacles enclosed with kit. Keep vias free of solder.
7.1		4	25-pin header, TH	SAM1213-25-ND	DNP: headers and receptacles enclosed with kit. Keep vias free of solder.
8	J5, J6	2	3-pin header, male, TH	SAM1035-03-ND	
9	JP5, JP6, JP7, JP8,JP9, JP10	6	3-pin header, male, TH	SAM1035-03-ND	place jumpers on pins 2-3
10	JP1, JP2	2	2-pin header, male, TH	SAM1035-02-ND	place jumper on header
10.1	JP4	1	2-pin header, male, TH	SAM1035-02-ND	place jumper on header
11	JP3	1	3-pin header, male, TH	SAM1035-03-ND	place jumper on pins 1-2
12		10	Jumper	15-38-1024-ND	Place on: JP1, JP2, JP3, JP4, JP5, JP6, JP7, JP8, JP9, JP10
13	JTAG	1	14-pin connector, male, TH	HRP14H-ND	
14	BOOTST	1	10-pin connector, male, TH	HRP10H-ND	DNP, keep vias free of solder
15	Q1	0	Crystal		DNP: Q1 Keep vias free of solder
16	Q2	1	Crystal		DNP: Q2 Keep vias free of solder
17	R3, R7	2	330 Ohm, SMD0805	541-330ATR-ND	
18	R1, R2, R4, R6, R8, R9, R10, R11, R12	3	0 Ohm, SMD0805	541-000ATR-ND	DNP: R6, R8, R9, R10, R11, R12
19	R5	1	47k Ohm, SMD0805	541-47000ATR-ND	
20	U1	1	Socket: IC357-1004-53N		Manuf.: Yamaichi
21	PCB	1	79.5 x 99.5 mm	MSP-TS430PZ100C Rev 1.0	2 layers
22	Rubber stand off	4		Buerklin: 20H1724	apply to corners at bottom side
23	MSP430	2	MSP430F643x		DNP: enclosed with kit. Is supplied by TI.
24	C16	1	4.7 nF SMD0603	Buerklin 53 D 2042	
26	D3, D4	2	LL103A	Buerklin: 24S3406	
27	JP11	1	4-pin header, male, TH	SAM1035-04-ND	Place jumper on Pin 1 and Pin 2
28	C15	1	4.7 uF, SMD0805	Buerklin 53 D 2430	
29	C21	1	220nF, SMD0805	Buerklin 53 D 2381	

B.33 MSP-TS430PZ100D

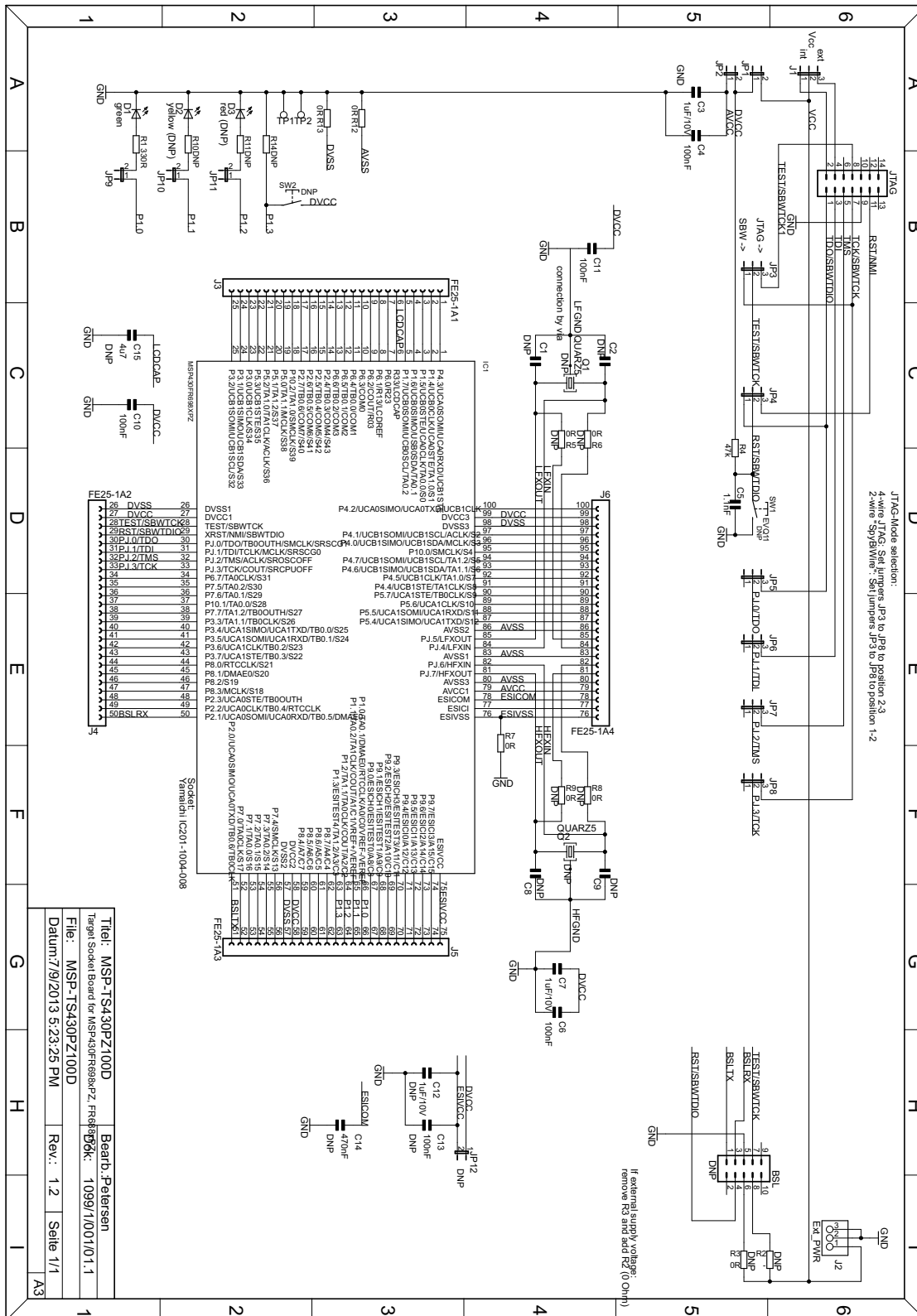

Figure B-66. MSP-TS430PZ100D Target Socket Module, Schematic

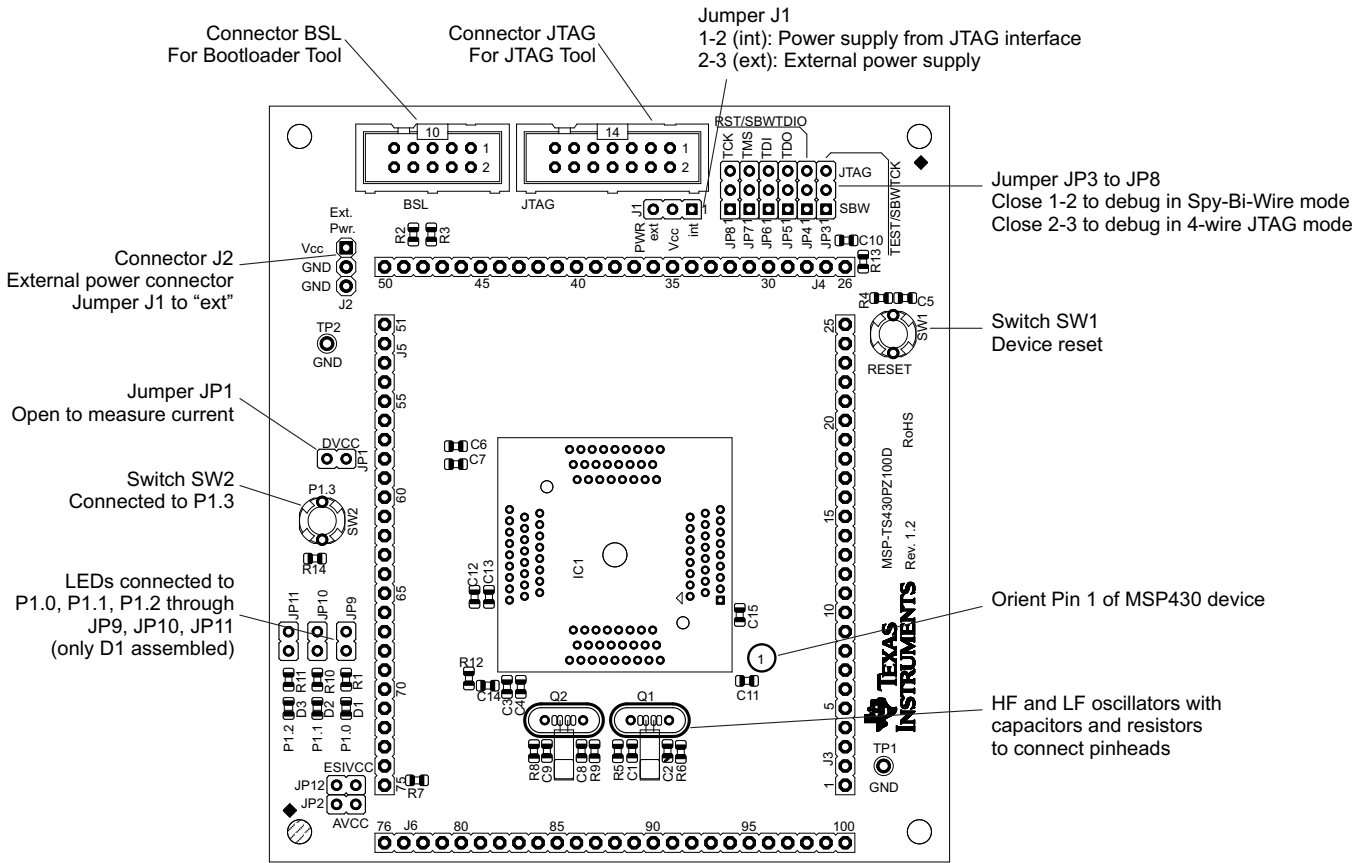

Figure B-67. MSP-TS430PZ100D Target Socket Module, PCB

Table B-34. MSP-TS430PZ100D Bill of Materials

Pos.	Ref Des	Number Per Board	Description	Digi-Key Part No.	Comment
1	PCB	1	90.0 x 100.0 mm	MSP-TS430PZ100D Rev 1.2	2 layers, white solder mask
2	JP1, JP2, JP9	3	2-pin header, male, TH	SAM1035-02-ND	place jumper on header
3	JP10, JP11, JP12	3	2-pin header, male, TH	SAM1035-02-ND	DNP, keep pads free of solder
4	J1	1	3-pin header, male, TH	SAM1035-03-ND	place jumpers on pins 1-2
5	JP3, JP4, JP5, JP6, JP7, JP8	6	3-pin header, male, TH	SAM1035-03-ND	place jumpers on pins 2-3
6	J2	1	3-pin header, male, TH	SAM1035-03-ND	
7	R2, R3, R5, R6, R8, R9	6	0R, 0805	541-0.0ATR-ND	DNP
8	R7, R12, R13	3	0R, 0805	541-0.0ATR-ND	
9	C5	1	1.1nF, CSMD0805	490-1623-2-ND	
10	C3, C7	2	1uF/10V, CSMD0805	490-1702-2-ND	
11	C12	1	1uF/10V, CSMD0805	490-1702-2-ND	DNP
12	R4	1	47k, 0805	541-47KATR-ND	
13	C4, C6, C10, C11	4	100nF, CSMD0805	490-1666-1-ND	
14	C13	1	100nF, CSMD0805	490-1666-1-ND	DNP
15	C15	1	4u7, CSMD0805	445-1370-1-ND	DNP
16	R1	1	330R, 0805	541-330ATR-ND	
17	C14	1	470nF, CSMD0805	587-1290-2-ND	DNP
18	R10, R11	2	330R, 0805	541-330ATR-ND	DNP
19	R14	1	47k, 0805	541-47KATR-ND	DNP
20	C1, C2, C8, C9	4	DNP, CSMD0805		DNP
21	SW2	1	EVQ-11L05R	P8079STB-ND	DNP
22	SW1	1	EVQ-11L05R	P8079STB-ND	DNP
23	J3, J4, J5, J6	4	25-pin header, TH	SAM1029-25-ND	DNP: headers and receptacles enclosed with kit. Keep vias free of solder. : Header
24	J3, J4, J5, J6	4	25-pin receptacle, TH	SAM1213-25-ND	DNP: headers and receptacles enclosed with kit. Keep vias free of solder. : Receptacle
25	TP1, TP2	2	Testpoint		DNP, keep pads free of solder
26	BSL	1	10-pin connector, male, TH	HRP10H-ND	DNP, keep vias free of solder
27	JTAG	1	14-pin connector, male, TH	HRP14H-ND	
28	IC1	1	Socket: IC201-1004-008		Manuf. Yamaichi
29	IC1	1	MSP430FR6989		DNP: enclosed with kit. Is supplied by TI
30	Q1	1	DNP: MS3V-TR1 (32768kHz/20ppm/12.5pF)	depends on application	Micro Crystal, DNP, enclosed in kit, keep vias free of solder
31	Q2	1	DNP, Crystal	depends on application	DNP, keep vias free of solder
32	D1	1	green LED, DIODE0805	P516TR-ND	
33	D3	1	red (DNP), DIODE0805		DNP
34	D2	1	yellow (DNP), DIODE0805		DNP
35	Rubber stand off	4		Buerklin: 20H1724	apply to corners at bottom side

B.34 MSP-TS430PZ5x100

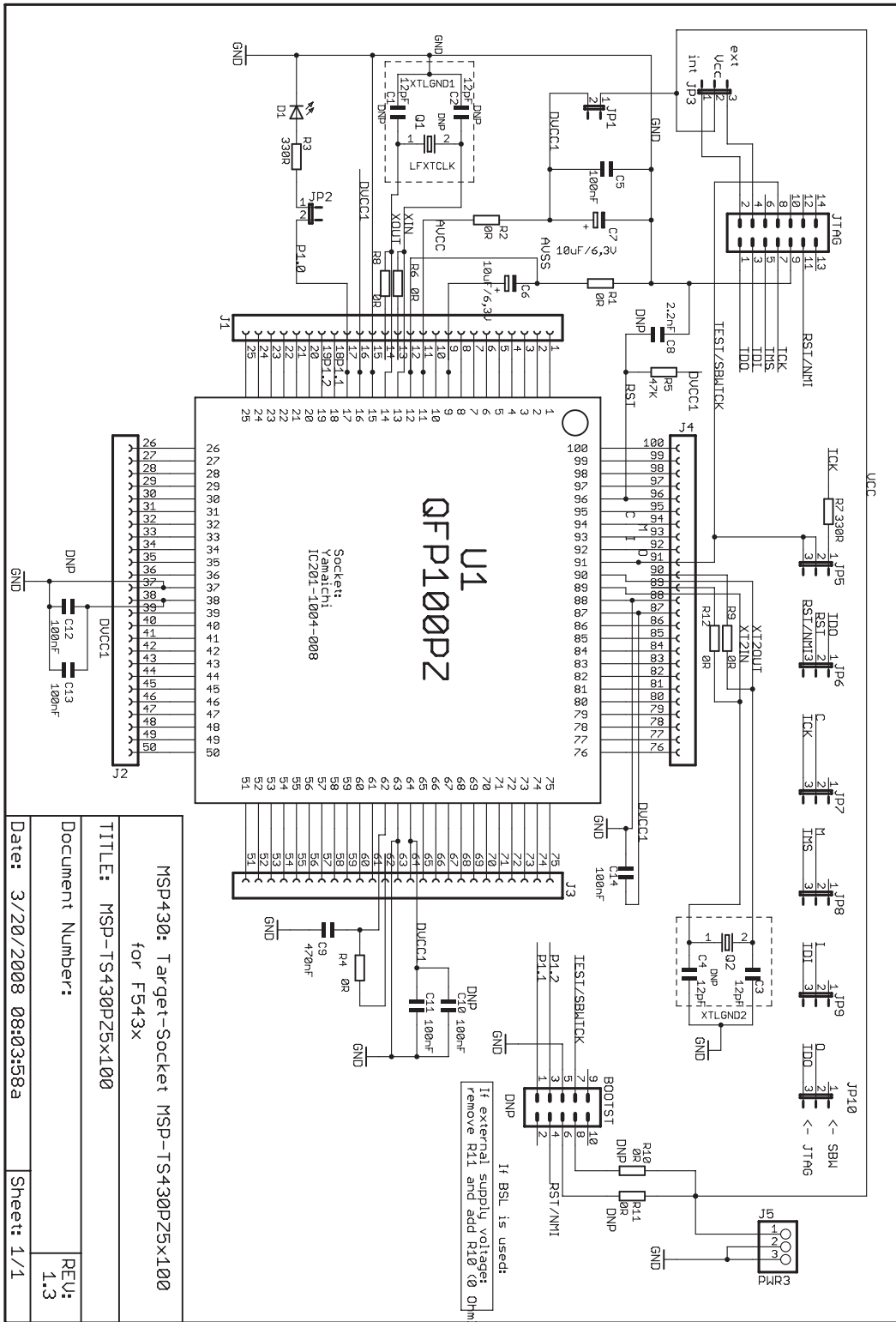

Figure B-68. MSP-TS430PZ5x100 Target Socket Module, Schematic

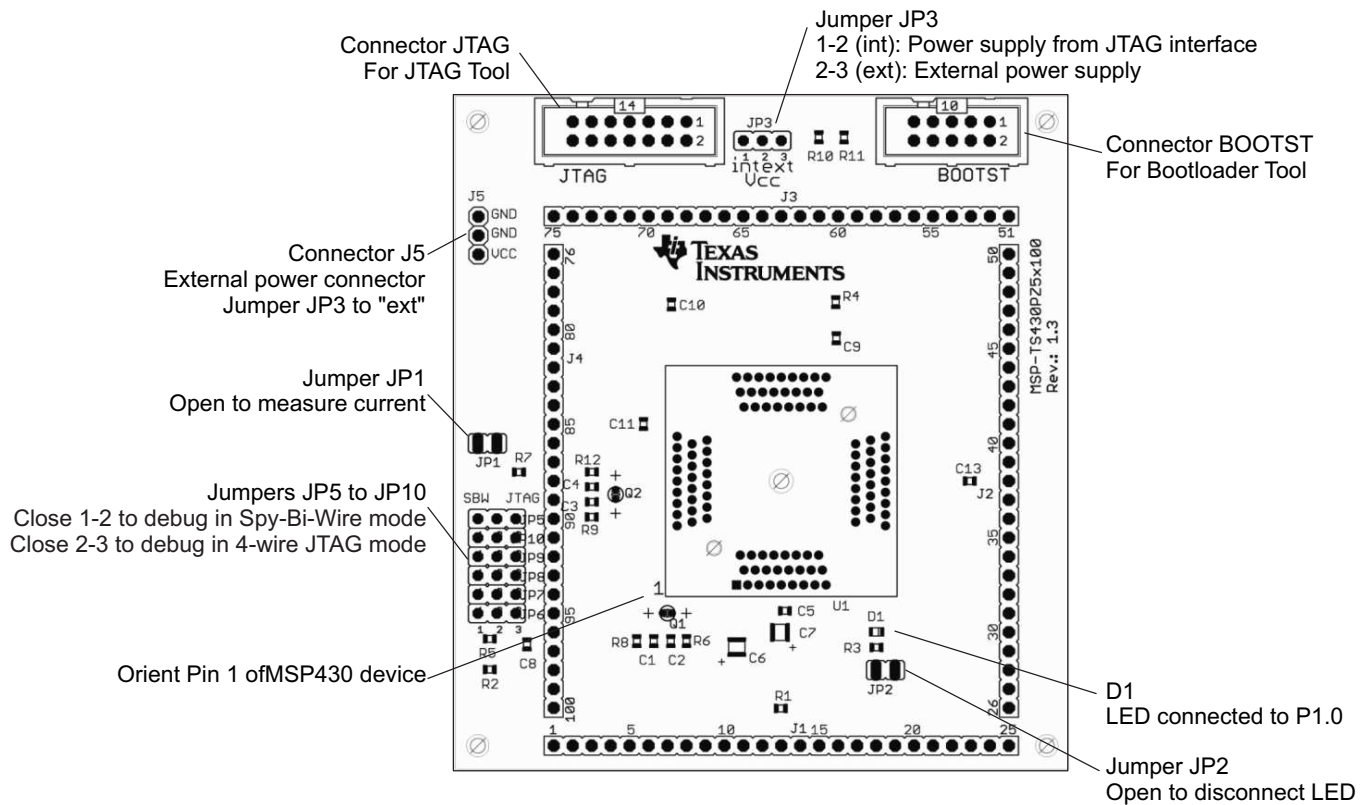

Figure B-69. MSP-TS430PZ5x100 Target Socket Module, PCB

Table B-35. MSP-TS430PZ5x100 Bill of Materials

Pos.	Ref Des	No. Per Board	Description	Digi-Key Part No.	Comment
1	C1, C2	0	12pF, SMD0805		DNP
1b	C3, C4		47pF, SMD0805		DNP: Only recommendation. Check your crystal spec.
2	C6, C7	2	10uF, 10V, Tantal Size B	511-1463-2-ND	
3	C5, C10, C11, C12, C13, C14	4	100nF, SMD0805	311-1245-2-ND	DNP: C12, C14
4	C8	0	2.2nF, SMD0805		DNP
5	C9	1	470nF, SMD0805	478-1403-2-ND	
6	D1	1	green LED, SMD0805	67-1553-1-ND	
7	J1, J2, J3, J4	0	25-pin header, TH	SAM1029-25-ND SAM1213-25-ND	DNP: headers and receptacles enclosed with kit. Keep vias free of solder. : Header : Receptacle
8	J5	1	3-pin header, male, TH	SAM1035-03-ND	
9	JP5, JP6, JP7, JP8, JP9, JP10	6	3-pin header, male, TH	SAM1035-03-ND	Place jumpers on pins 2-3
10	JP1, JP2	2	2-pin header, male, TH	SAM1035-02-ND	Place jumper on header
11	JP3	1	3-pin header, male, TH	SAM1035-03-ND	Place jumper on pins 1-2
12		9	Jumper	15-38-1024-ND	Place on JP1, JP2, JP3, JP5, JP6, JP7, JP8, JP9, JP10
13	JTAG	1	14-pin connector, male, TH	HRP14H-ND	
14	BOOTST	0	10-pin connector, male, TH		DNP: Keep vias free of solder
15	Q1, Q2	0	Crystal	Q1: Micro Crystal MS1V-T1K 32.768kHz, C(Load) = 12.5pF	DNP: Keep vias free of solder
16	R3, R7	2	330 Ω , SMD0805	541-330ATR-ND	
17	R1, R2, R4, R6, R8, R9, R10, R11, R12	3	0 Ω , SMD0805	541-000ATR-ND	DNP: R6, R8, R9, R10, R11, R12
18	R5	1	47k Ω , SMD0805	541-47000ATR-ND	
19	U1	1	Socket: IC357-1004-53N		Manuf.: Yamaichi
20	PCB	1	90 x 82 mm		2 layers
21	Rubber standoff	4		Select appropriate	Apply to corners at bottom side
22	MSP430	2	MSP430F5438IPZ		DNP: Enclosed with kit supplied by TI

B.35 MSP-TS430PZ100USB

Due to the use of diodes in the power chain, the voltage on the MSP430F5xx device is approximately 0.3 V lower than is set by the debugging tool. Set the voltage in the IDE to 0.3 V higher than desired; for example, to run the MCU at 3.0 V, set it to 3.3 V.

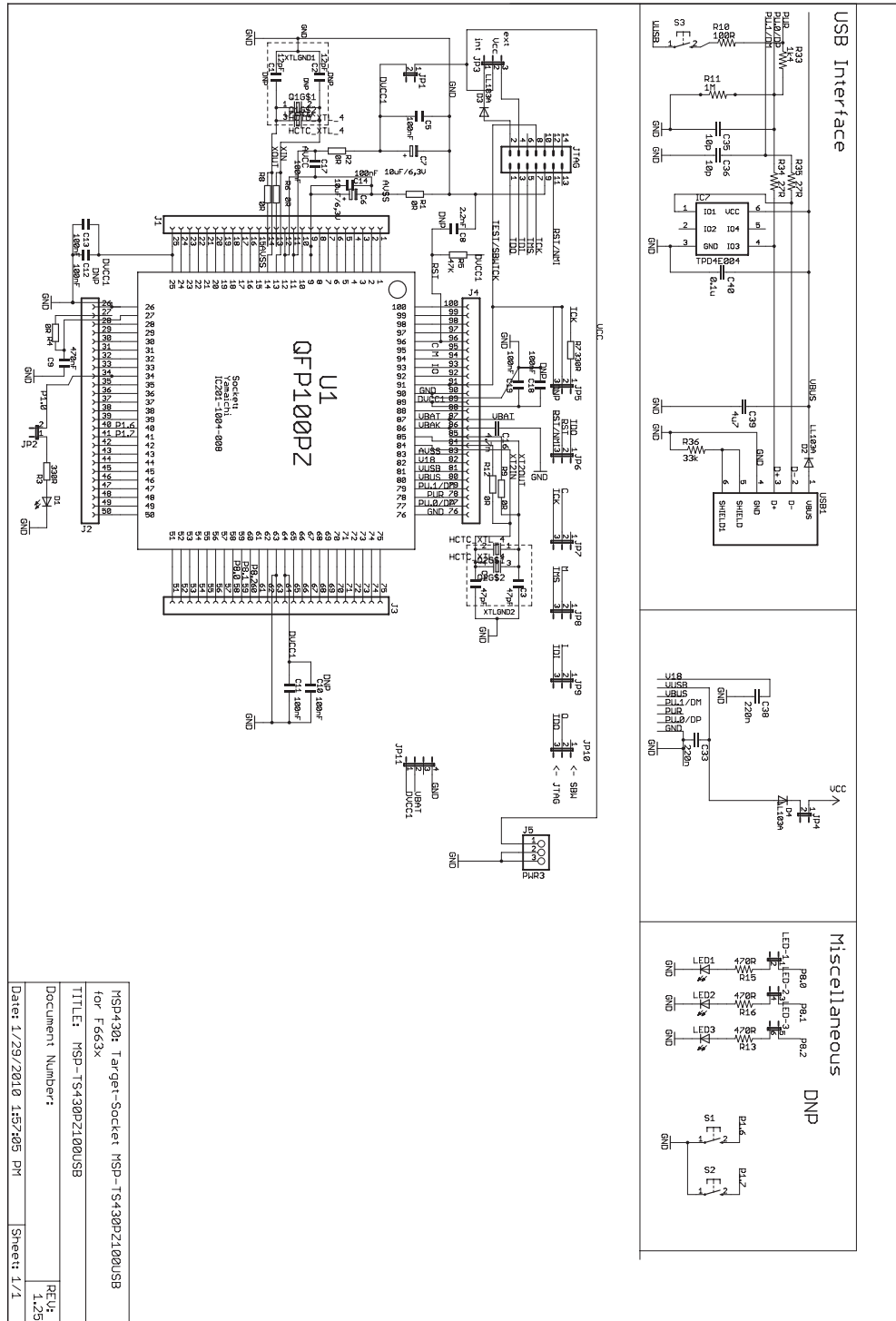

Figure B-70. MSP-TS430PZ100USB Target Socket Module, Schematic

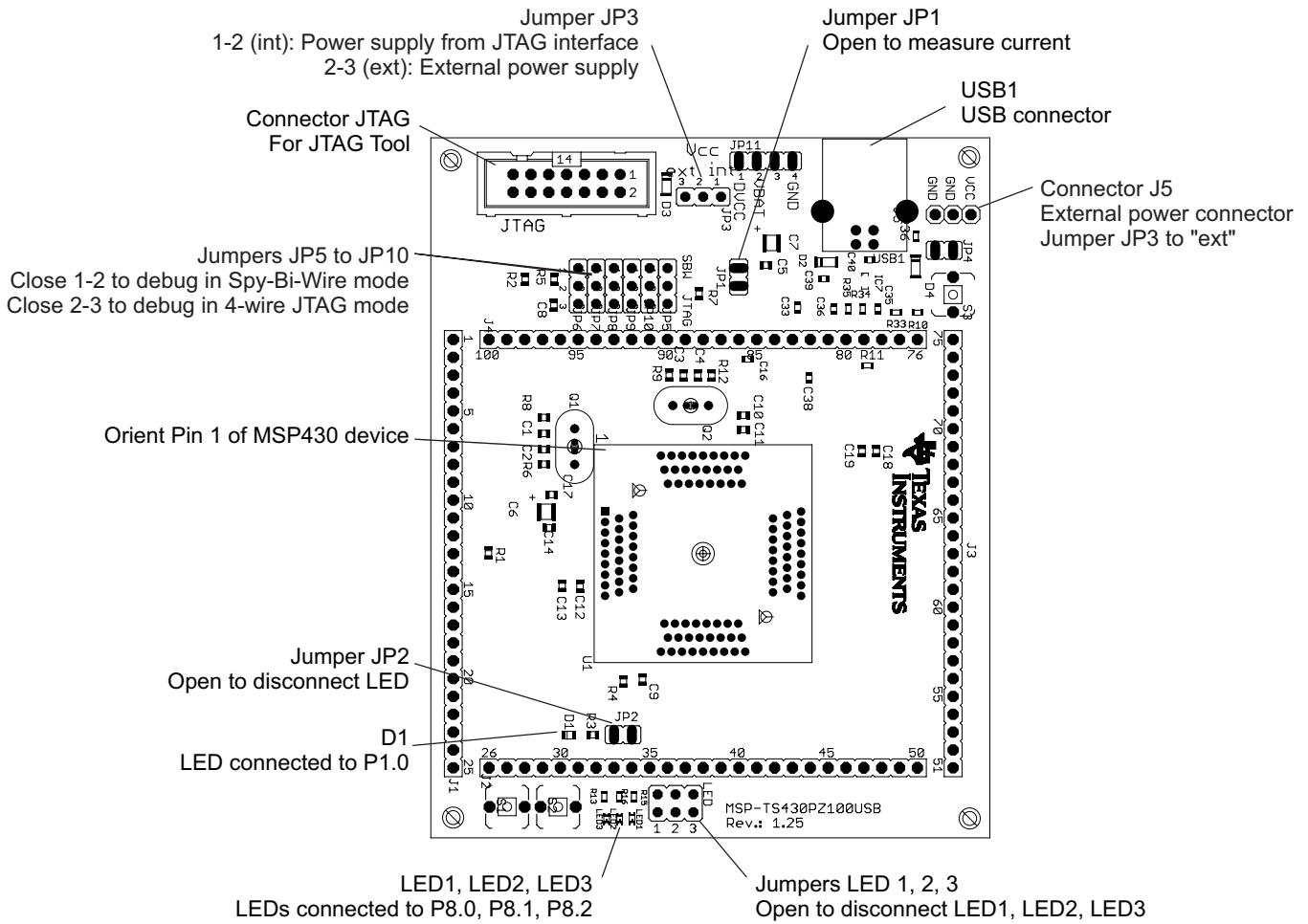

Figure B-71. MSP-TS430PZ100USB Target Socket Module, PCB

Table B-36. MSP-TS430PZ100USB Bill of Materials

Pos.	Ref Des	No. Per Board	Description	Digi-Key Part No.	Comment
1	C1, C2	0	12pF, SMD0805		DNP: C1, C2
1.1	C3, C4	2	47pF, SMD0805		
2	C6, C7	2	10uF, 6.3V, Tantal Size B	511-1463-2-ND	
3	C5, C11, C13, C14, C19	5	100nF, SMD0805	311-1245-2-ND	
3.1	C10, C12, C18, C17	0	100nF, SMD0805	311-1245-2-ND	DNP: C10, C12,C18, C17
4	C8	1	2.2nF, SMD0805		
5	C9	1	470nF, SMD0805	478-1403-2-ND	
6	D1	1	green LED, SMD0805	P516TR-ND	
7	J1, J2, J3, J4	4	25-pin header, TH	SAM1029-25-ND	DNP: headers and receptacles enclosed with kit. Keep vias free of solder. : Header : Receptacle
7.1		4	25-pin header, TH	SAM1213-25-ND	DNP: headers and receptacles enclosed with kit. Keep vias free of solder. : Header : Receptacle
8	J5	1	3-pin header, male, TH	SAM1035-03-ND	
9	JP5, JP6, JP7, JP8, JP9, JP10	6	3-pin header, male, TH	SAM1035-03-ND	place jumpers on pins 2-3
10	JP1, JP2, JP4	3	2-pin header, male, TH	SAM1035-02-ND	place jumper on header
11	JP3	1	3-pin header, male, TH	SAM1035-03-ND	place jumper on pins 1-2
12		10	Jumper	15-38-1024-ND	Place on: JP1, JP2, JP3, JP4, JP5, JP6, JP7, JP8, JP9, JP10
13	JTAG	1	14-pin connector, male, TH	HRP14H-ND	
14	Q1	0	Crystal	Micro Crystal MS1V-T1K 32.768kHz, C(Load) = 12.5pF	DNP: Q1. Keep vias free of solder
15	Q2	1	Crystal	Q2: 4MHz, Buerklin: 78D134	
16	R3, R7	2	330 Ω , SMD0805	541-330ATR-ND	
17	R1, R2, R4, R6, R8, R9, R12	3	0 Ω , SMD0805	541-000ATR-ND	DNP: R6, R8, R9, R12
18	R10	1	100 Ω , SMD0805	Buerklin: 07E500	
18	R11	1	1M Ω , SMD0603		not existing in Rev 1.0
18	R5	1	47k Ω , SMD0805	541-47000ATR-ND	
19	U1	1	Socket:IC201-1004-008		Manuf.: Yamaichi
20	PCB	1	79 x 77 mm		2 layers
21	Rubber stand off	4		Buerklin: 20H1724	apply to corners at bottom side
22	MSP430	2	MSP430F6638IPZ		DNP: enclosed with kit. Is supplied by TI
23	Insulating disk to Q2	1	Insulating disk to Q2	http://www.ettinger.de/Art_Detail.cfm?ART_ARTNUM=70.08.121	
24	C16	1	4.7 nF SMD0603		
27	C33	1	220n SMD0603	Buerklin: 53D2074	
28	C35, C36	2	10p SMD0603	Buerklin: 56D102	
30	C38	1	220n SMD0603	Buerklin: 53D2074	
31	C39	1	4u7 SMD0603	Buerklin: 53D2086	

Table B-36. MSP-TS430PZ100USB Bill of Materials (continued)

Pos.	Ref Des	No. Per Board	Description	Digi-Key Part No.	Comment
32	C40	1	0.1u SMD0603	Buerklin: 53D2068	
33	D2, D3, D4	3	LL103A	Buerklin: 24S3406	
34	IC7	1	TPD4E004		Manu: TI
35	LED	0	JP3QE	SAM1032-03-ND	DNP
36	LED1, LED2, LED3	0	LEDCHIPLED_0603	FARNELL: 852-9833	DNP
37	R13, R15, R16	0	470R SMD0603	Buerklin: 07E564	DNP
38	R33	1	1k4 / 1k5 SMD0603	Buerklin: 07E612	
39	R34	1	27R SMD0603	Buerklin: 07E444	
40	R35	1	27R SMD0603	Buerklin: 07E444	
41	R36	1	33k SMD0603	Buerklin: 07E740	
42	S1, S2, S3	1	PB	P12225STB-ND	DNP S1 and S2. (Only S3)
43	USB1	1	USB_RECEPTACLE	FARNELL: 117-7885	
44	JP11	1	4-pin header, male, TH	SAM1035-04-ND	place jumper only on Pin 1

B.36 MSP-TS430PZ100AUSB

The development board MSP-TS430PZ100AUSB supports the MSP430FG662x and MSP430FG642x flash devices in the 100-pin QFP package. MSP430FG6626IPZ devices are not included in the MSP-TS430PZ100AUSB kit. Free samples can be ordered from www.ti.com/product/MSP430FG6626/samplebuy.

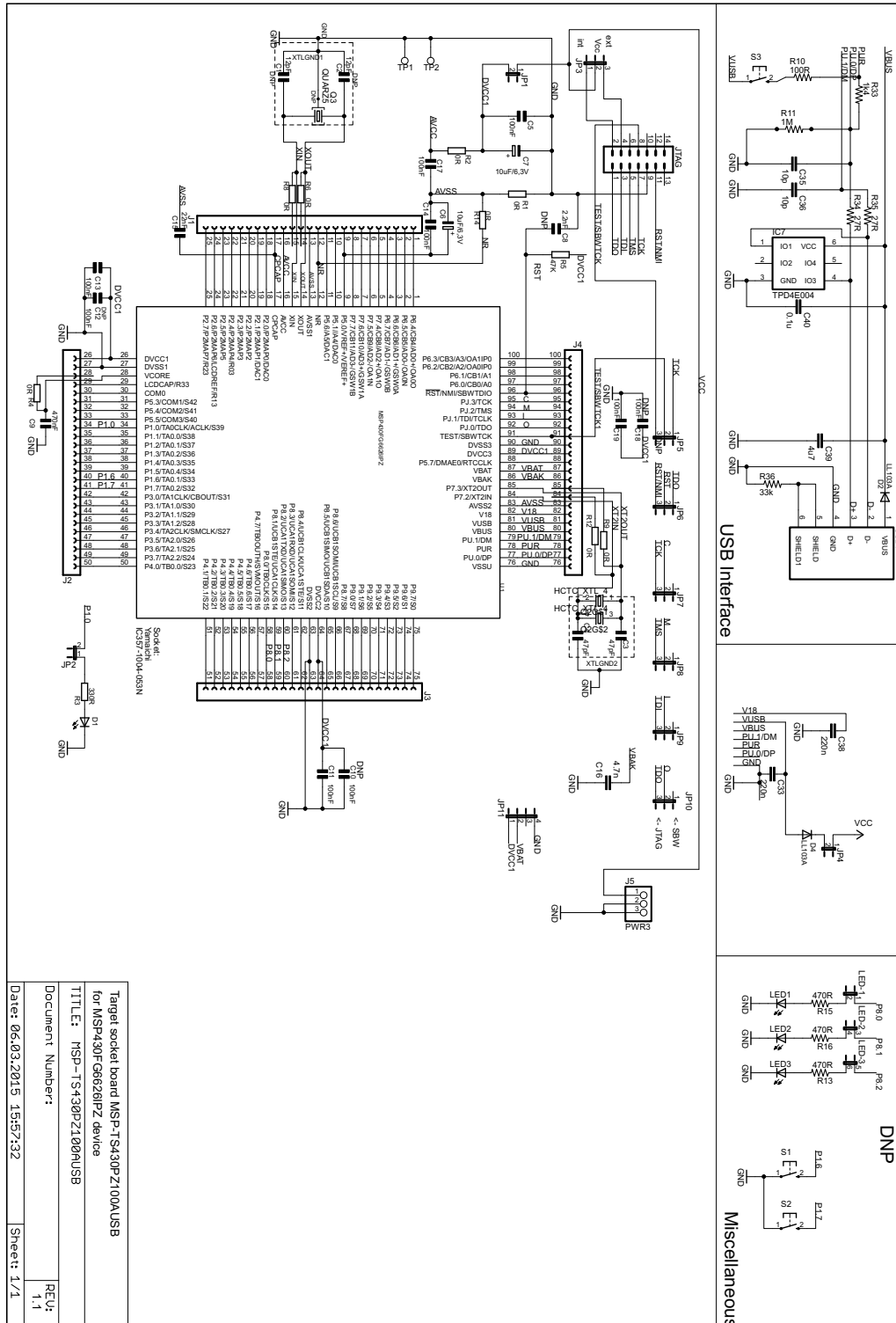

Figure B-72. MSP-TS430PZ100AUSB Target Socket Module, Schematic

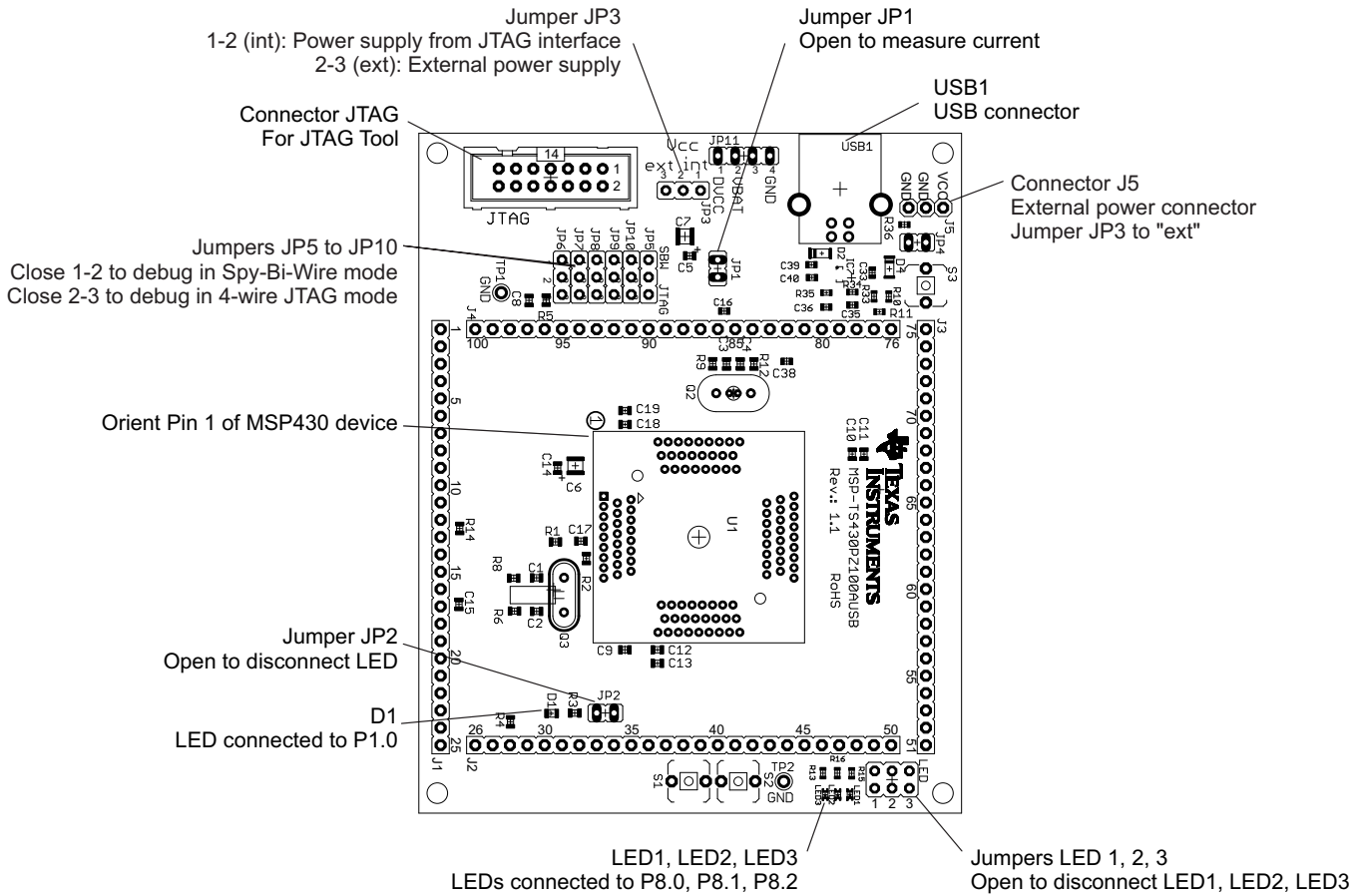

Figure B-73. MSP-TS430PZ100AUSB Target Socket Module, PCB

Table B-37. MSP-TS430PZ100AUSB Bill of Materials

Pos.	Ref Des	No. Per Board	Description	Digi-Key Part No.	Comment
1	PCB Rev. 1.1	1	99.65mm x 79.54mm		2 layers, red solder mask
2	C1, C2	2	12pF, SMD0805		DNP: C1, C2
3	C10, C12, C17, C18	9	100nF, SMD0805	311-1245-2-ND	DNP: C10, C12,C18, C17
4	C15	1	22nF, CSMD0805	311-1242-1-ND	
5	C16	1	4.7 nF SMD0603	311-1250-1-ND	
6	C3, C4	2	47pF, CSMD0805	709-1337-1-ND	
7	C33, C38	2	220n SMD0603		Buerklin: 53D2074
8	C35, C36	2	10p SMD0603		Buerklin: 56D102
9	C39	1	4u7 SMD0603		Buerklin: 53D2086
10	C40	1	0.1u SMD0603		Buerklin: 53D2068
11	C5, C11, C13, C14, C19	5	100nF, SMD0805	311-1245-2-ND	
12	C6, C7	2	10uF/6.3V, Tantal Size B	511-1463-2-ND	
13	C8	1	2.2nF, CSMD0805	709-1339-1-ND	
14	C9	1	470nF, SMD0805	478-1403-2-ND	
15	D1	1	green LED, HSMG-C170 DIODE0805	516-1434-1-ND	Avago, Farnell 5790852
16	D2, D4	2	LL103A, SOD-80		Buerklin: 24S3406
17	IC7	1	TPD4E004DRYR	296-23618-1-ND	Manu: TI
18	J1, J2, J3, J4	4	25-pin header, TH	SAM1029-25-ND	DNP: Headers enclosed in kit. Keep vias free of solder.
19	J1, J2, J3, J4	4	25-pin receptacle, TH	SAM1213-25-ND	DNP: Receptacles enclosed in kit. Keep vias free of solder.
20	J5	1	3-pin header, male, TH	SAM1035-03-ND	
21	JP1, JP2, JP4	3	2-pin header, male, TH	SAM1035-02-ND	place jumper on header
22	JP11	1	4-pin header, male, TH	SAM1035-04-ND	Place jumper on Pin 1 and 2
23	JP3	1	3-pin header, male, TH	SAM1035-03-ND	place jumper on pins 1-2
24	JP5, JP6, JP7, JP8, JP9, JP10	6	3-pin header, male, TH	SAM1035-03-ND	place jumpers on pins 2-3
25	Jumpers for JP1, JP2, JP3, JP4, JP5, JP6, JP7, JP8, JP9, JP10, JP11	11	Jumper	15-38-1024-ND	
26	JTAG	1	14-pin connector, male, TH	HRP14H-ND	
27	LED	1	JP3QE	SAM1032-03-ND	DNP
28	LED1, LED2, LED3	3	FARNELL: 852-9833		DNP
29	MSP430	2	MSP430FG6626IPZ		DNP: Free samples can be ordered in the TI Store
30	Q2	1	Crystal	Q2: 4MHz Buerklin: 78D134	
31	Q3	1	MS3V-T1R (32.768kHz/ 20ppm/12.5pF)		
32	R1, R2, R4	3	0 Ohm, SMD0805	541-0.0ATR-ND	
33	R10	1	100R, R0603	541-100GCT-ND	
34	R11	1	1M, R0603	541-1.0MGCT-ND	
35	R13, R15, R16	3	470R SMD0603	Buerklin: 07E564	DNP
36	R14	1	0 Ohm, SMD0805	541-0.0ATR-ND	
37	R3	1	330 Ohm, SMD0805	541-330ATR-ND	

Table B-37. MSP-TS430PZ100AUSB Bill of Materials (continued)

Pos.	Ref Des	No. Per Board	Description	Digi-Key Part No.	Comment
38	R33	1	1k4 / 1k5 SMD0603		Buerklin: 07E612
39	R34, R35	2	27R SMD0603		Buerklin: 07E444
40	R36	1	33k SMD0603		Buerklin: 07E740
41	R5	1	47k Ohm, SMD0805	541-47000ATR-ND	
42	R6, R8, R9, R12	4	0 Ohm, SMD0805	541-000ATR-ND	DNP
43	S1, S2	1	PB	P12225STB-ND	DNP
44	S3	1	PB	P12225STB-ND	
45	TP1, TP2	2	Test point		DNP, Keep vias free of solder
46	U1	1	Socket: IC357-1004-53N		Manuf.: Yamaichi
47	USB1	1	USB Receptacle		FARNELL: 117-7885
48	Insulating disk for Q2	1	Insulating disk for Q2		ettinger.de 70.08.121
49	Rubber stand off	4		Buerklin: 20H1724	Apply to corners at bottom side

B.37 MSP-TS430PEU128

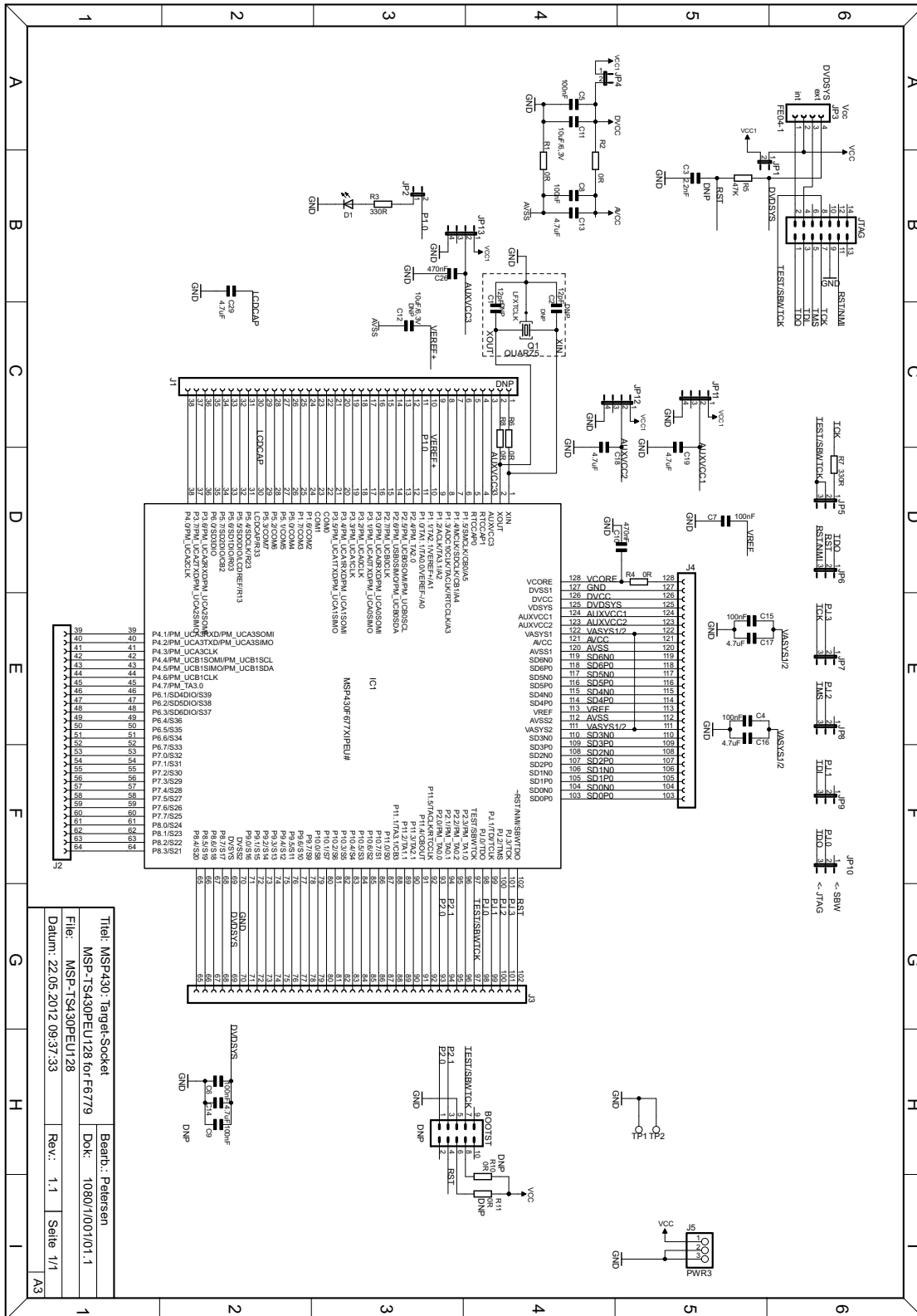

Figure B-74. MSP-TS430PEU128 Target Socket Module, Schematic

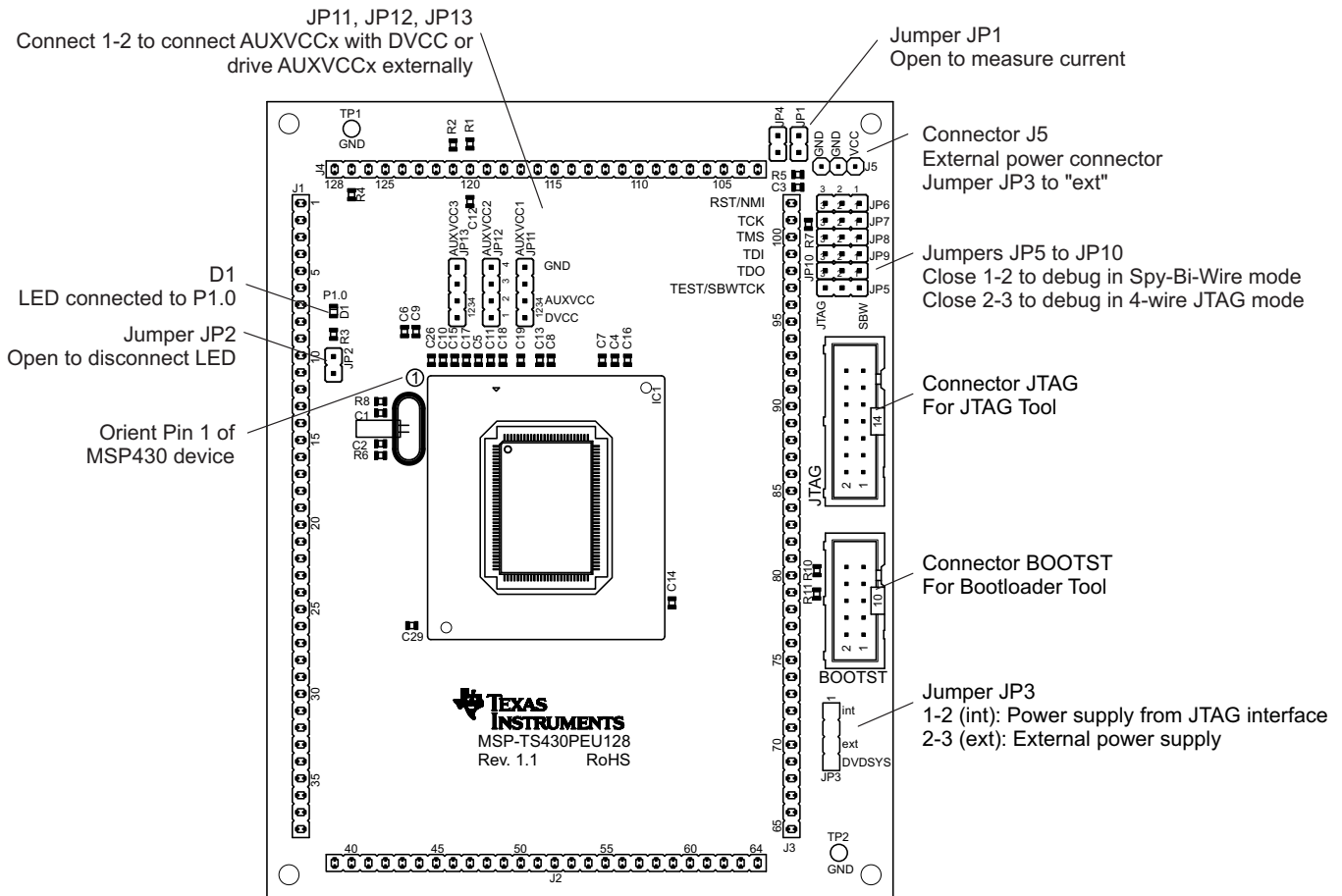

Figure B-75. MSP-TS430PEU128 Target Socket Module, PCB

NOTE: For bootloader use, the BSL connector and only one of the resistors R10 or R11 must be populated. If the board is supplied internally, R11 (0 Ω) must be assembled. If the board is supplied externally, R10 (0 Ω) must be assembled, and R11 must be removed.

NOTE: The MSP-TS430PEU128 Rev 1.1 ships with the following modifications:

- R7 value is changed to 0 Ω instead of 330 Ω.
- JTAG pin 8 is connected only to JP5 pin 3, and not to pin 2.
- JP5 pin 2 is connected to IC1 pin 97.
- BOOTST pin 7 is connected to IC1 pin 97.

Table B-38. MSP-TS430PEU128 Bill of Materials

Pos.	Ref Des	No. Per Board	Description	Digi-Key Part No.	Comment
1	PCB	1	94x119.4mm, 4 layers	MSP-TS430PEU128 Rev. 1.1	4 layers, green solder mask
2	D1	1	green LED, DIODE0805	516-1434-1-ND	
3	JP1, JP2, JP4	3	2-pin header, male, TH	SAM1035-02-ND	Place jumper on header
4	JP5, JP6, JP7, JP8, JP9, JP10	6	3-pin header, male, TH	SAM1035-03-ND	Place jumpers on pins 1-2 (SBW)
5	JP11, JP12, JP13	3	4-pin header, male, TH	SAM1035-04-ND	Place jumpers on pins 1-2 (AVCC=VCC)
6	JP3	1	4-pin header, male, TH	SAM1035-04-ND	Place jumpers on pins 1-2
7	JP1, JP2, JP3, JP4, JP5, JP6, JP7, JP8, JP9, JP10, JP11, JP12, JP13	13	Jumper	WM4592-ND	
8	R1, R2, R4, R6, R8	5	0R, 0805	541-0.0ATR-ND	
9	R10, R11	2	0R, 0805	541-0.0ATR-ND	DNP
10	C3	1	2.2nF, CSMD0805	490-1628-2-ND	DNP
11	C13, C14, C16, C17, C18, C19, C29	7	4.7uF, 6.3V, CSMD0805	587-1302-2-ND	
12	C11	1	10uF, 6.3V, CSMD0805	445-1372-2-ND	
13	C12	1	10uF, 6.3V, CSMD0805	445-1372-2-ND	DNP
14	C1, C2	2	12pF, CSMD0805	490-5531-2-ND	DNP
15	R5	1	47K, 0805	311-47KARTR-ND	
16	C4, C5, C6, C7, C8, C15	6	100nF, CSMD0805	311-1245-2-ND	
17	C9	1	100nF, CSMD0805	311-1245-2-ND	DNP
18	R3, R7	2	330R, 0805	541-330ATR-ND	
19	C10, C26	2	470nF, CSMD0805	587-1282-2-ND	
20	BOOTST	1	10-pin connector, male, TH	HRP10H-ND	DNP, keep vias free of solder
21	JTAG	1	14-pin connector, male, TH	HRP14H-ND	
22	IC1 Socket	1	Socket: IC500-1284-009P		Manuf. Yamaichi
23	IC1	2	MSP430F67791IPEU		DNP: enclosed with kit. Is supplied by TI
24	J5	1	3-pin header, male, TH	SAM1035-03-ND	
25	Q1	1	Crystal: MS3V-T1R 32.768kHz 12.5pF ±20ppm		DNP: Crystal enclosed with kit. Keep vias free of solder
26	TP1, TP2	2	Test point		DNP, keep vias free of solder
27	J2, J4	2	26-pin header, TH	SAM1029-26-ND	DNP: Headers enclosed with kit. Keep vias free of solder.
28	J2, J4	2	26-pin receptacle, TH	SAM1213-26-ND	DNP: Receptacles enclosed with kit. Keep vias free of solder.
29	J1, J3	2	38-pin header, TH	SAM1029-38-ND	DNP: Headers enclosed with kit. Keep vias free of solder.
30	J1, J3	2	38-pin receptacle, TH	SAM1213-38-ND	DNP: Receptacles enclosed with kit. Keep vias free of solder.
31	Rubber feet	4	Rubber feet	Buerklin: 20H1724	apply to bottom side corners

B.38 EM430F5137RF900

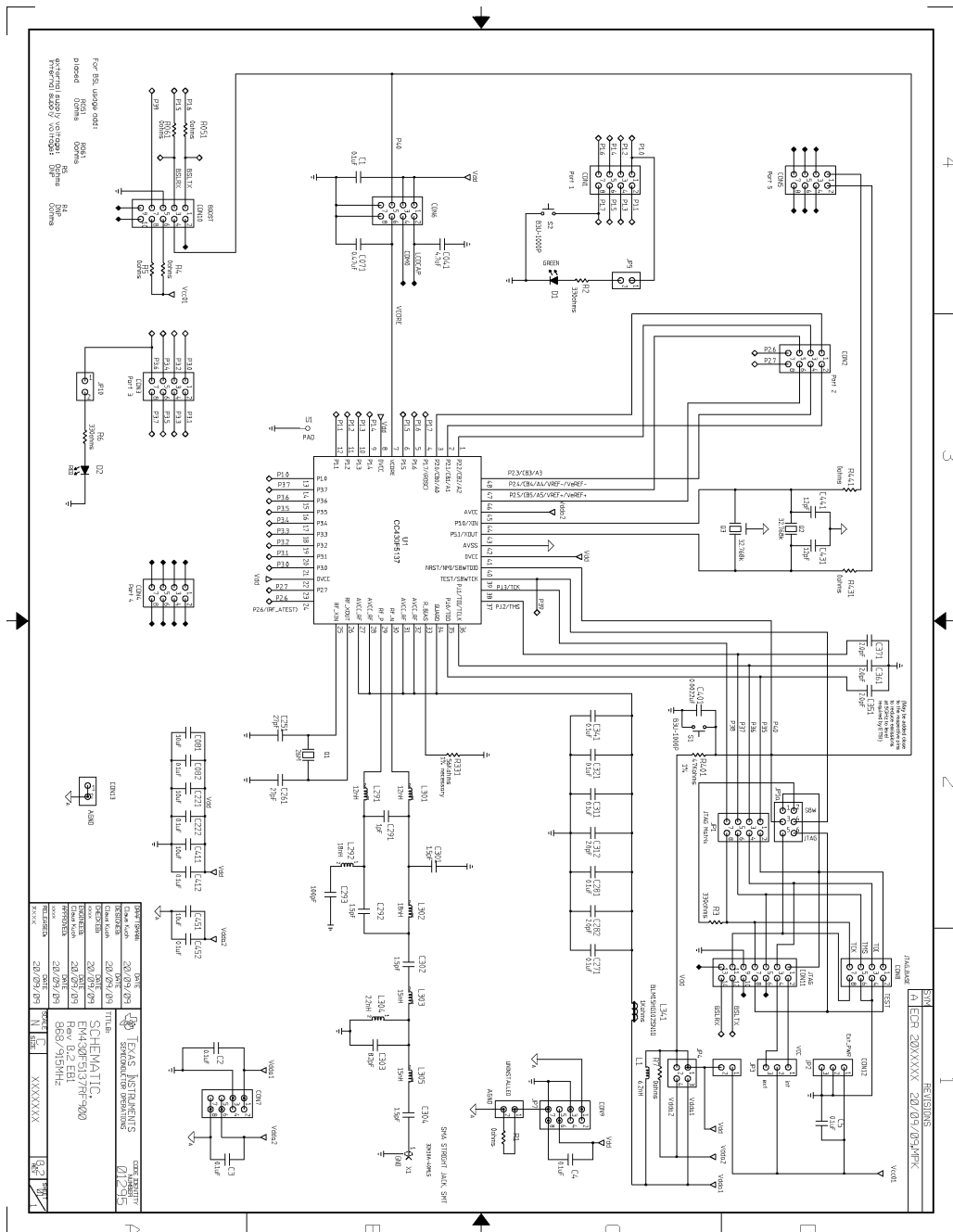

- Power Management**
- VCC01 = external VCC
- Vdd = DVCC
- Vdda1 = AVDD_RF / AVCC_RF
- Vdda2 = AVCC

- Port connectors**
- CON1 ..
- CON3 = Port1 .. Ports of cc430
- CON4 = spare
- CON5 = 1: XIN 2: XOUT
- CON6 = Vdd, GND, Vcore, COM0, LCDCAP
- CON7 = Vdda1, Vdda2, GND, AGND
- CON8 = JTAG_BASE (JTAG_Port)
- CON9 = Vdd, GND, AGND

Figure B-76. EM430F5137RF900 Target Board, Schematic

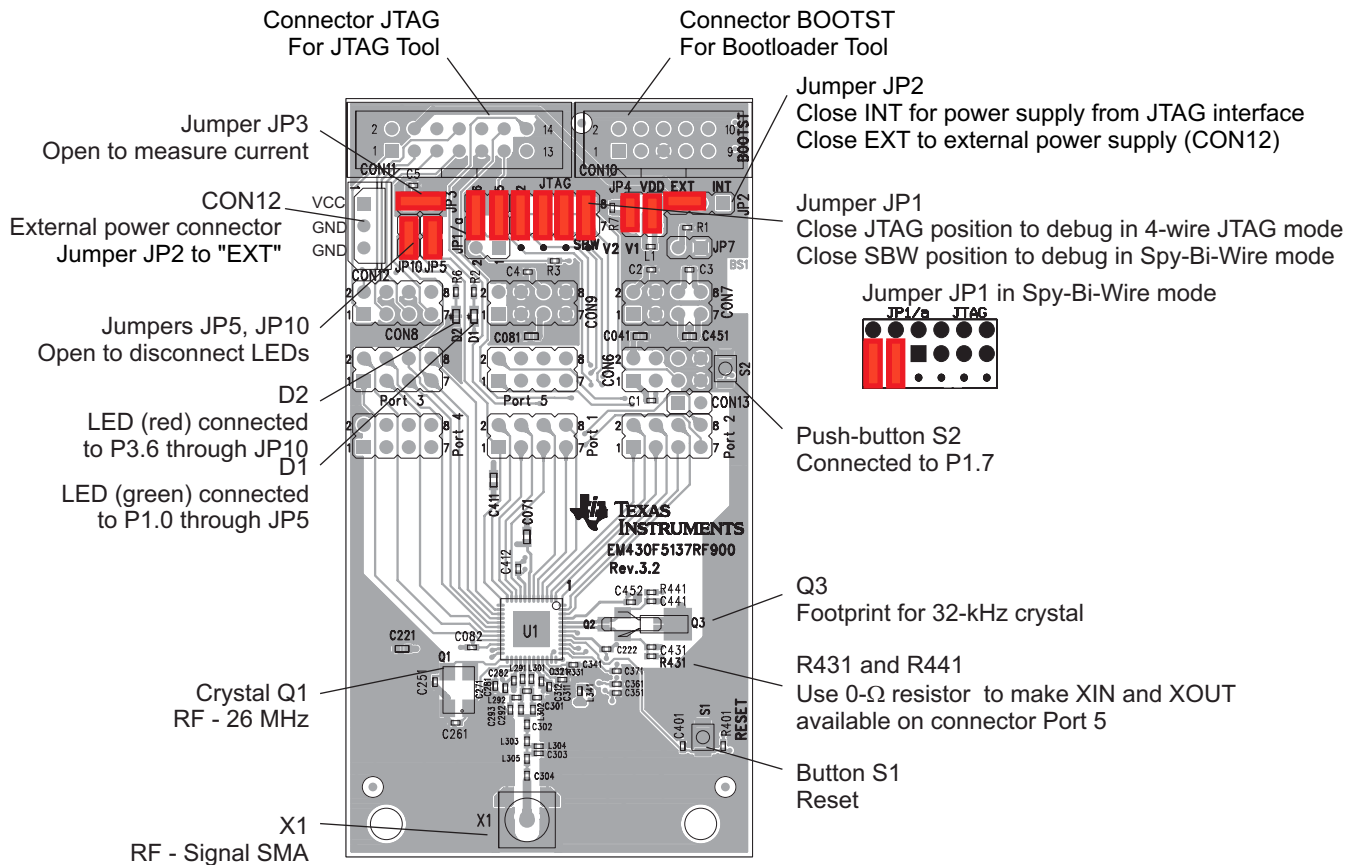

Figure B-77. EM430F5137RF900 Target board, PCB

The battery pack that is included with the EM430F5137RF900 kit may be connected to CON12. Ensure correct battery insertion regarding the polarity as indicated in battery holder.

Table B-39. EM430F5137RF900 Bill of Materials

Item	Reference	No. per Board	Description	Value	Manufacturer's Part Number	Manufacturer	Comment
1	Q1	1	(CUSTOMER SUPPLY) CRYSTAL, SMT, 4P, 26MHz	26M	ASX-531(CS)	AKER ELECTRONIC	
2	C1-C5, C082, C222, C271, C281, C311, C321, C341, C412, C452	14	CAPACITOR, SMT, 0402, CER, 16V, 10%, 0.1uF	0.1uF	0402YC104KAT2A	AVX	
3	C071	1	CAPACITOR, SMT, 0603, CERAMIC, 0.47uF, 16V, 10%, X5R	0.47uF	0603YD474KAT2A	AVX	
4	R401	1	RES0402, 47.0K	47kΩ	CRCW04024702F100	DALE	
5	CON11	1	HEADER, THU, MALE, 14P, 2X7, 25.4x9.2x9.45mm		09 18 514 6323	HARTING	
6	CON10	0	HEADER, THU, MALE, 10P, 2X5, 20.32x9.2x9.45mm		09 18 510 6323	HARTING	DNP
7	D1	1	LED, SMT, 0603, GREEN, 2.1V	active	APT1608MGC	KINGBRIGHT	
8	D2	1	LED, SMT, 0603, RED, 2.0V	active	APT1608EC	KINGBRIGHT	
9	Q3	0	UNINSTALLED CRYSTAL, SMT, 3P, MS1V (Customer Supply)	32.768k	MS1V-T1K (UN)	MICRO CRYSTAL	DNP
10	CON12	1	HEADER, THU, MALE, 3P, 1x3, 9.9x4.9x5.9mm		22-03-5035	MOLEX	
11	C251, C261	2	50V, 5%, 27pF	27pF	GRM36COG270J50	MURATA	
12	L341	1	FERRITE, SMT, 0402, 1.0kΩ, 250mA	1kΩ	BLM15HG102SN1D	MURATA	
13	C293	1	CAPACITOR, SMT, 0402, CERAMIC, 100pF, 50V, 0.25pF, C0G(NP0)	100pF	GRM1555C1H101JZ01	MURATA	
14	L304	1	INDUCTOR, SMT, 0402, 2.2nH, 0.1nH, 220mA, 500MHz	0.0022u H	LQP15MN2N2B02	MURATA	
15	L303, L305	2	INDUCTOR, SMT, 0402, 15nH, 2%, 450mA, 250MHz	0.015uH	LQW15AN15NG00	MURATA	
16	L292, L302	2	INDUCTOR, SMT, 0402, 18nH, 2%, 370mA, 250MHz	0.018uH	LQW15AN18NG00	MURATA	
17	C291	1	CAPACITOR, SMT, 0402, CERAMIC, 1pF, 50V, 0.05pF, C0G(NP0)	1pF	GRM1555C1H1R0WZ01	MURATA	
18	C303	1	CAPACITOR, SMT, 0402, CERAMIC, 8.2pF, 50V, 0.05pF, C0G(NP0)	8.2pF	GRM1555C1H8R2WZ01	MURATA	
19	C292, C301- C302, C304	4	CAPACITOR, SMT, 0402, CERAMIC, 1.5pF, 50V, 0.05pF, C0G(NP0)	1.5pF	GRM1555C1H1R5WZ01	MURATA	
20	L291, L301	2	INDUCTOR, SMT, 0402, 12nH, 2%, 500mA, 250MHz	0.012uH	LQW15AN12NG00	MURATA	
21	C282, C312, C351, C361, C371	5	CAPACITOR, SMT, 0402, CERAMIC, 2pF, 50V, 0.1pF, C0G	2.0pF	GRM1555C1H2R0BZ01	Murata	
22	L1	1	INDUCTOR, SMT, 0402, 6.2nH, 0.1nH, 130mA, 500MHz	6.2nH	LQP15MN6N2B02	Murata	
23	S1-S2	2	ULTRA-SMALL TACTILE SWITCH, SMT, 2P, SPST-NO, 1.2x3x2.5mm, 0.05A, 12V		B3U-1000P	OMRON	
24	R4-R5, R051, R061, R431, R441	0	UNINSTALLED RESISTOR/JUMPER, SMT, 0402, 0 Ω, 5%, 1/16W	0Ω	ERJ-2GE0R00X	PANASONIC	DNP
24a	R7	1	RESISTOR/JUMPER, SMT, 0402, 0 Ω, 5%, 1/16W	0Ω	ERJ-2GE0R00X	PANASONIC	

Table B-39. EM430F5137RF900 Bill of Materials (continued)

Item	Reference	No. per Board	Description	Value	Manufacturer's Part Number	Manufacturer	Comment
25	R2-R3, R6	3	RESISTOR, SMT, 0402, THICK FILM, 5%, 1/16W, 330	330Ω	ERJ-2GEJ331	PANASONIC	
26	C431, C441	0	CAPACITOR, SMT, 0402, CER, 12pF, 50V, 5%, NPO	12pF	ECJ-0EC1H120J	PANASONIC	
27	C401	1	CAPACITOR, SMT, 0402, CER, 2200pF, 50V, 10%, X7R	0.0022uF	ECJ-0EB1H222K	PANASONIC	
28	R331	1	RESISTOR, SMT, THICK FILM, 56K, 1/16W, 5%	56kΩ	ERJ-2GEJ563	PANASONIC	
29	C081, C221, C411, C451	4	CAPACITOR, SMT, 0603, CERAMIC, 10uF, 6.3V, 20%, X5R	10uF	ECJ-1VB0J106M	PANASONIC	
30	R1	1	RESISTOR/JUMPER, SMT, 0402, 0 Ω, 5%, 1/16W	0Ω	ERJ-2GE0R00X	PANASONIC	
31	C041	0	UNINSTALLED CAP CERAMIC 4.7UF 6.3V X5R 0603	4.7uF	ECJ-1VB0J475K	Panasonic	DNP
32	X1	1	SMA STRIGHT JACK, SMT		32K10A-40ML5	ROSENBERGER	
33	Q2	0	Crystal, SMT, 32.768 kHz	32.768k	MS3V-T1R	Micro Crystal	DNP
34	U1	1	DUT, SMT, PQFP, RGZ-48, 0.5mmLS, 7.15x7.15x1mm, THRM.PAD		CC430F5137	TI	
35	JP1	1	Pin Connector 2x4pin		61300821121	WUERTH	
36	CON1-CON9	0	Pin Connector 2x4pin		61300821121	WUERTH	DNP
37	JP2	1	Pin Connector 1x3pin		61300311121	WUERTH	
38	JP3, JP5, JP10	3	Pin Connector 1x2pin		61300211121	WUERTH	
38a	JP7, CON13	0	Pin Connector 1x2pin		61300211121	WUERTH	DNP
39	JP4	1	Pin Connector 2x2pin		61300421121	WUERTH	DNP
40	JP1a	1	Pin Connector 2x3pin		61300621121	WUERTH	

B.39 EM430F6137RF900

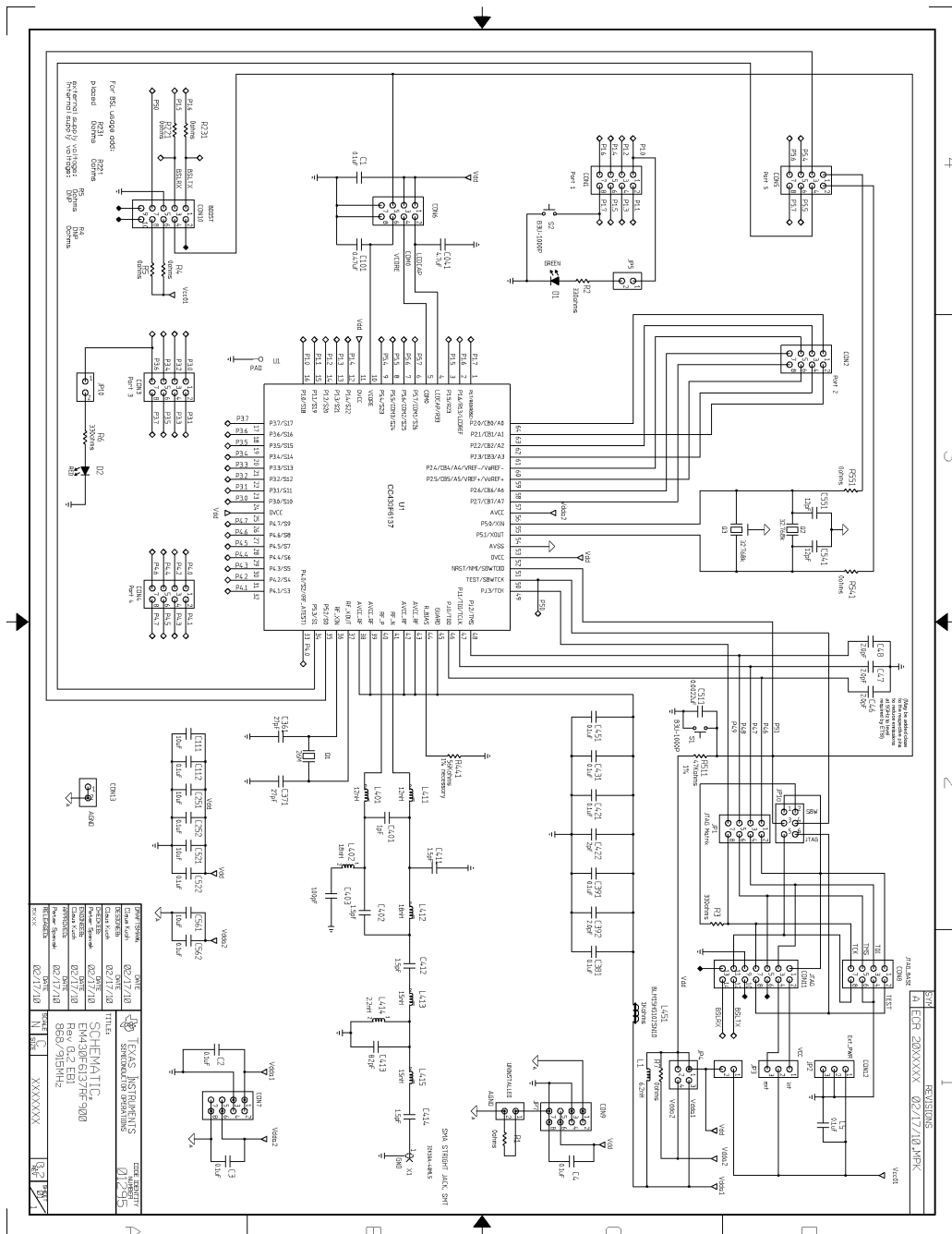

- Power Management**
- VCC01 = external VCC
- Vdd = DVCC
- Vdda1 = AVDD_RF / AVCC_RF
- Vdda2 = AVCC

- Port connectors**
- CON1 ..
- CON5 = Port1 .. Ports of cc430
- CON6 = Vdd, GND, Vcore, COM0, LCDCAP
- CON7 = Vdda1, Vdda2, GND, AGND
- CON8 = JTAG_BASE (JTAG Port)
- CON9 = Vdd, GND, AGND

Figure B-78. EM430F6137RF900 Target Board, Schematic

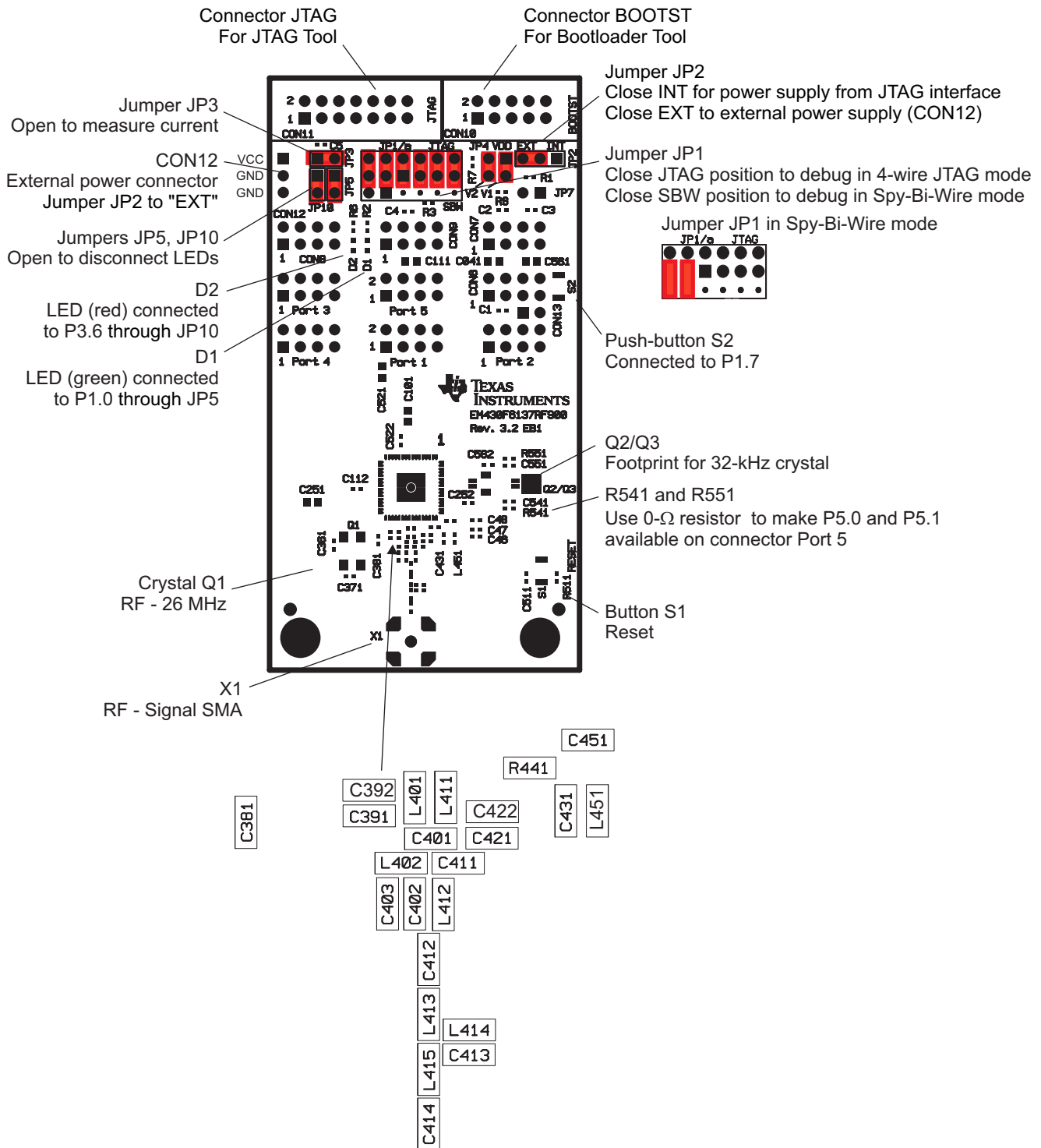

Figure B-79. EM430F6137RF900 Target Board, PCB

The battery pack that is included with the EM430F6137RF900 kit may be connected to CON12. Ensure correct battery insertion regarding the polarity as indicated in battery holder.

Table B-40. EM430F6137RF900 Bill of Materials

Pos.	Ref Des	No. per Board	Description	Part No.	Manufacturer
1	Q1	1	(CUSTOMER SUPPLY) CRYSTAL, SMT, 4P, 26MHz	ASX-531(CS)	AKER ELECTRONIC
2	C1-C5, C112, C252, C381, C391, C421, C431, C451, C522, C562	14	CAPACITOR, SMT, 0402, CER, 16V, 10%, 0.1uF	0402YC104KAT2A	AVX
3	C101	1	CAPACITOR, SMT, 0603, CERAMIC, 0.47uF, 16V, 10%, X5R	0603YD474KAT2A	AVX
4	R511	1	RES0402, 47.0K	CRCW04024702F100	DALE
5	CON11	1	HEADER, THU, MALE, 14P, 2X7, 25.4x9.2x9.45mm, 90deg	09 18 514 6323	HARTING
7	D1	1	LED, SMT, 0603, GREEN, 2.1V	APT1608MGC	KINGBRIGHT
8	D2	1	LED, SMT, 0603, RED, 2.0V	APT1608EC	KINGBRIGHT
10	CON12	1	HEADER, THU, MALE, 3P, 1x3, 9.9x4.9x5.9mm	22-03-5035	MOLEX
11	C361, C371	2	50V, ±5%, 27pF	GRM36COG270J50	MURATA
12	L451	1	FERRITE, SMT, 0402, 1.0kΩ, 250mA	BLM15HG102SN1D	MURATA
13	C403	1	CAPACITOR, SMT, 0402, CERAMIC, 100pF, 50V, ±0.25pF, C0G(NP0)	GRM1555C1H101JZ01	MURATA
14	L414	1	INDUCTOR, SMT, 0402, 2.2nH, ±0.2nH, 1000mA, 250MHz	LQW15AN2N2C10	MURATA
15	L413, L415	2	INDUCTOR, SMT, 0402, 15nH, ±5%, 460mA, 250MHz	LQW15AN15NJ00	MURATA
16	L402, L412	2	INDUCTOR, SMT, 0402, 18nH, ±5%, 370mA, 250MHz	LQW15AN18NJ00	MURATA
17	C401	1	CAPACITOR, SMT, 0402, CER, 1pF, 50V, ±0.25pF, NP0	GJM1555C1H1R0CB01D	MURATA
18	C413	1	CAPACITOR, SMT, 0402, CERAMIC, 8.2pF, 50V, ±0.25pF, C0G(NP0)	GRM1555C1H8R2CZ01	MURATA
19	C402, C411-C412, C414	4	CAPACITOR, SMT, 0402, CERAMIC, 1.5pF, 50V, ±0.25pF, C0G(NP0)	GRM1555C1H1R5CZ01	MURATA
20	L401, L411	2	INDUCTOR, SMT, 0402, 12nH, ±5%, 500mA, 250MHz	LQW15AN12NJ00	MURATA
21	C46-C48, C392, C422	5	CAPACITOR, SMT, 0402, CERAMIC, 2.0pF, 50V, ±0.25pF, C0G(NP0)	GRM1555C1H2R0CZ01	Murata
22	L1	1	INDUCTOR, SMT, 0402, 6.2nH, ±0.1nH, 700mA, 250MHz	LQW15AN6N2D00	Murata
23	S1-S2	2	ULTRA-SMALL TACTILE SWITCH, SMT, 2P, SPST-NO, 1.2x3x2.5mm, 0.05A, 12V	B3U-1000P	OMRON
24	R7	1	RESISTOR/JUMPER, SMT, 0402, 0 Ω, 5%, 1/16W	ERJ-2GE0R00X (UN)	PANASONIC
25	R2-R3, R6	3	RESISTOR, SMT, 0402, THICK FILM, 5%, 1/16W, 330	ERJ-2GEJ331	PANASONIC
27	C511	1	CAPACITOR, SMT, 0402, CER, 2200pF, 50V, 10%, X7R	ECJ-0EB1H222K	PANASONIC
28	C111, C251, C521, C561	4	CAPACITOR, SMT, 0603, CERAMIC, 10uF, 6.3V, 20%, X5R	ECJ-1VB0J106M	PANASONIC
28a	C041	1	CAP CERAMIC 4.7UF 6.3V X5R 0603	ECJ-1VB0J475M	PANASONIC
29	R441	1	RESISTOR, SMT, THICK FILM, 56K, 1/16W, 1%	ERJ-2RKF5602	PANASONIC
30	R1	1	RESISTOR/JUMPER, SMT, 0402, 0 Ω, 5%, 1/16W	ERJ-2GE0R00X	PANASONIC
31	X1	1	SMA STRIGHT JACK, SMT	32K10A-40ML5	ROSENBERGER
33	U1	1	DUT, SMT, PQFP, RGC-64, 0.5mmLS, 9.15x9.15x1mm, THRM.PAD	CC430F6137	TI
34	JP1	1	Pin Connector 2x4pin	61300821121	WUERTH

Table B-40. EM430F6137RF900 Bill of Materials (continued)

Pos.	Ref Des	No. per Board	Description	Part No.	Manufacturer
35	JP2	1	Pin Connector 1x3pin	61300311121	WUERTH
36a	JP3, JP5, JP10	3	Pin Connector 1x2pin	61300211121	WUERTH
38	JP1a	1	Pin Connector 2x3pin	61300621121	WUERTH

B.40 EM430F6147RF900

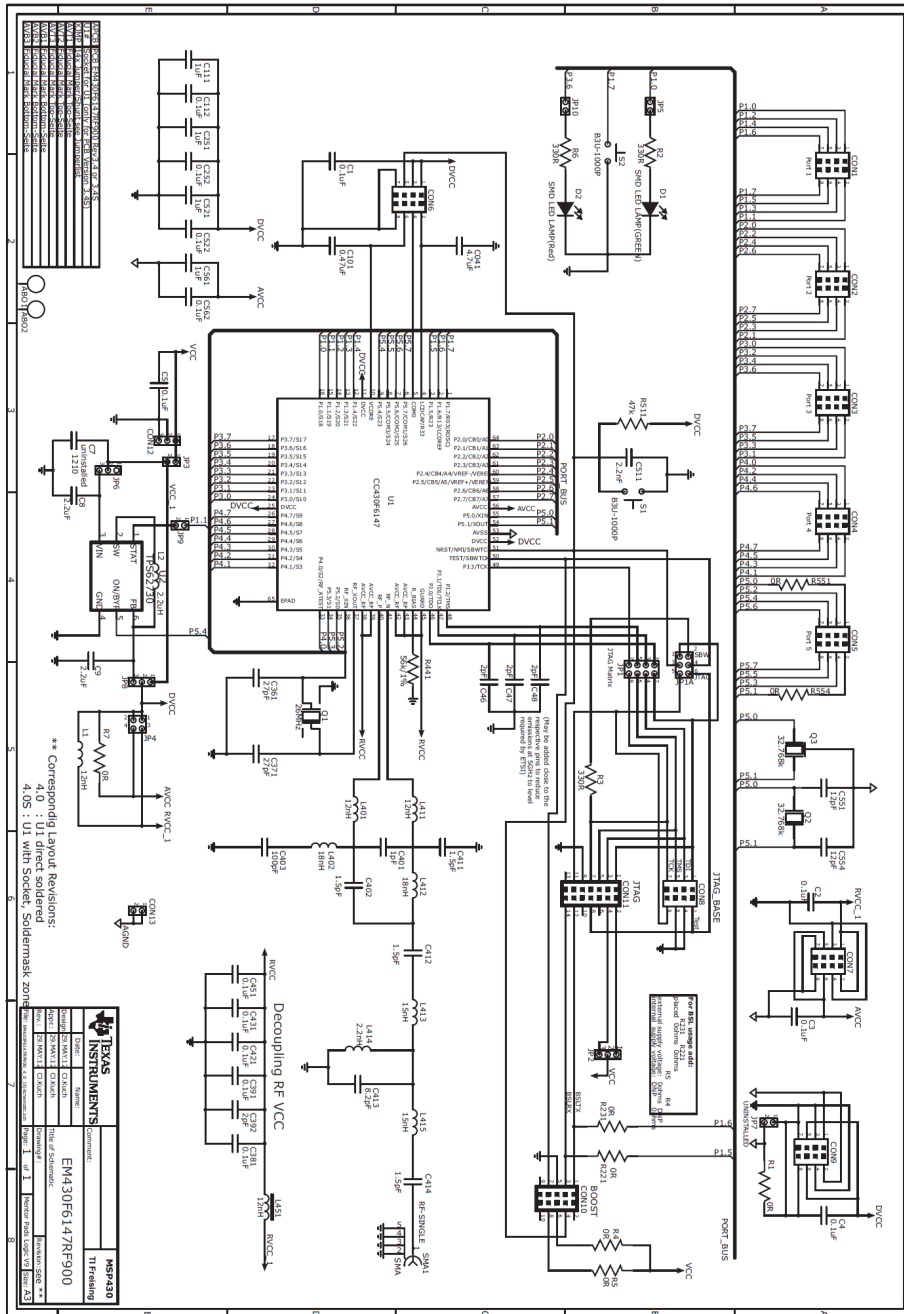

- Power Management**
- VCC = external VCC
- DVCC = Digital VCC
- AVCC = Analog VCC
- RVCC = RF-VCC

- Port connectors**
- CON1 ..
- CON5 = Port1 .. Port5 of ccd430
- CON6 = DVCC, GND, Vcore, COM0, LCDCAP
- CON7 = RFVCC, AVCC, GND, AGND
- CON8 = JTAG, BASE (JTAG Port)
- CON9 = DVCC, GND, AGND

Figure B-80. EM430F6147RF900 Target Board, Schematic

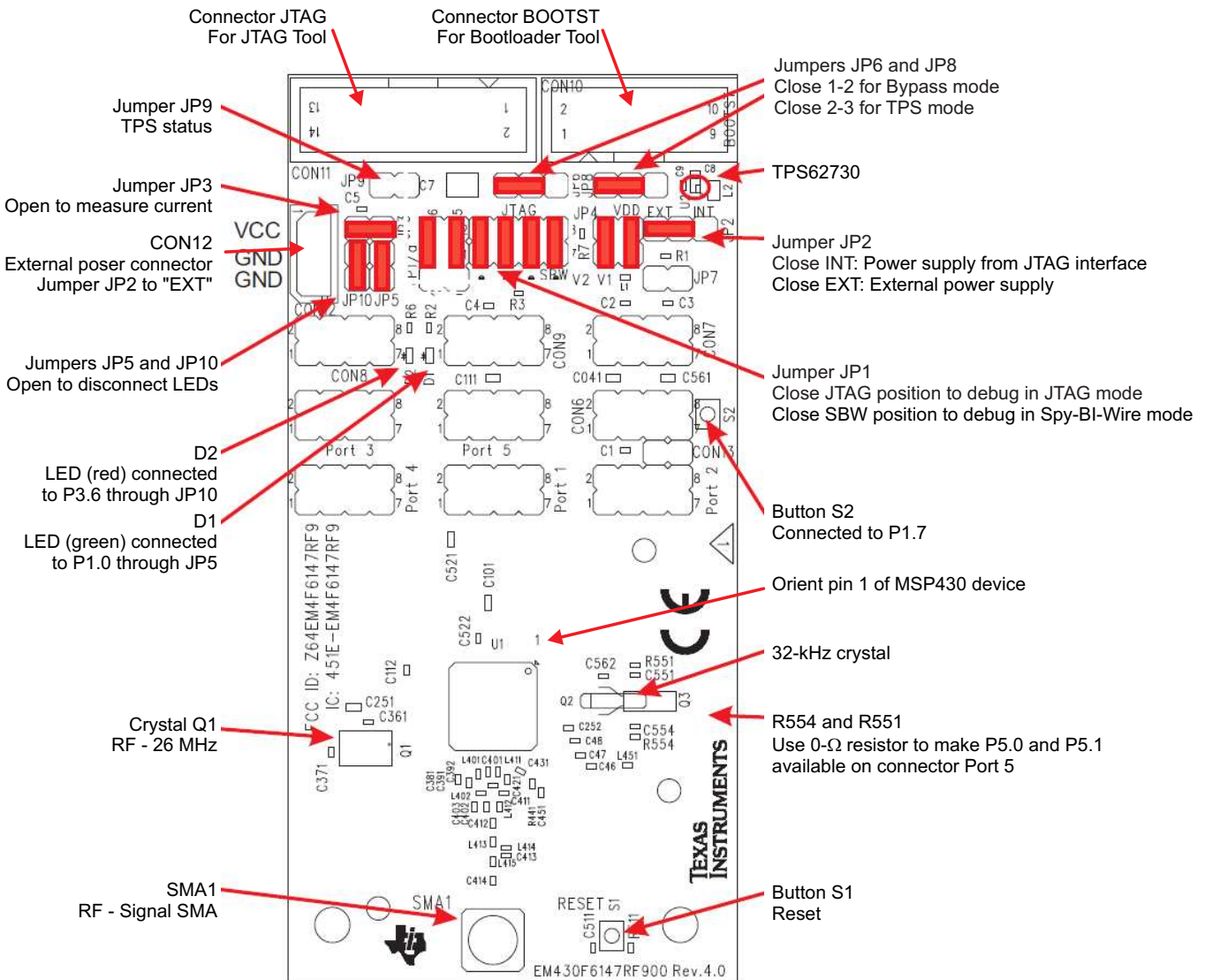

Figure B-81. EM430F6147RF900 Target Board, PCB

The battery pack which comes with the EM430F6147RF900 kit may be connected to CON12. Ensure correct battery insertion regarding the polarity as indicated in battery holder.

Table B-41. EM430F6147RF900 Bill of Materials

Pos.	Ref Des	No. per Board	Description	Part No.	Manufacturer
1	Q1	1	(CUSTOMER SUPPLY) CRYSTAL, SMT, 4P, 26MHz	ASX-531(CS)	AKER ELECTRONIC
2	C1-5 C112 C252 C381 C391 C421 C431 C451 C522 C562	14	CAPACITOR, SMT, 0402, CER, 16V, 10%, 0.1uF	0402YC104KAT2A	AVX
3	C101	1	CAPACITOR, SMT, 0603, CERAMIC, 0.47uF, 16V, 10%, X5R	0603YD474KAT2A	AVX
4	R511	1	RES0402, 47.0K	CRCW04024702F100	DALE
5	CON11	1	HEADER, THU, MALE, 14P, 2X7, 25.4x9.2x9.45mm, 90deg	09 18 514 6323	HARTING
7	D1	1	LED, SMT, 0603, GREEN, 2.1V	APT1608MGC	KINGBRIGHT
8	D2	1	LED, SMT, 0603, RED, 2.0V	APT1608EC	KINGBRIGHT
10	CON12	1	HEADER, THU, MALE, 3P, 1x3, 9.9x4.9x5.9mm	22-03-5035	MOLEX
11	C361, C371	2	50V, ±5%, 27pF	GRM36COG270J50	MURATA
12	L451	1	Inductor, SMD, 0402, 12nH, 5%, 370mA	LQW15AN12NJ00	MURATA
13	C403	1	CAPACITOR, SMT, 0402, CERAMIC, 100pF, 50V, ±0.25pF, C0G(NP0)	GRM1555C1H101JZ01	MURATA
14	L414	1	INDUCTOR, SMT, 0402, 2.2nH, ±0.2nH, 1000mA, 250MHz	LQW15AN2N2C10	MURATA
15	L413	1	Inductor, SMD, 0402, 15nH, 5%, 370mA, 250MHz	LQW15AN15NJ00	MURATA
15	L415	1	INDUCTOR, SMT, 0402, 15nH, ±5%, 460mA, 250MHz	LQW15AN15NJ00	MURATA
16	L402, L412	2	Inductor, SMD, 0402, 18nH, 5%, 460mA, 250MHz	LQW15AN18NJ00	MURATA
17	C401	1	CAPACITOR, SMT, 0402, CER, 1pF, 50V, ±0.25pF, NP0	GJM1555C1H1R0CB01D	MURATA
18	C413	1	CAPACITOR, SMT, 0402, CERAMIC, 8.2pF, 50V, ±0.25pF, C0G(NP0)	GRM1555C1H8R2CZ01	MURATA
19	C402, C411- C412, C414	4	CAPACITOR, SMT, 0402, CERAMIC, 1.5pF, 50V, ±0.25pF, C0G(NP0)	GRM1555C1H1R5CZ01	MURATA
20	L1, L401, L411	3	INDUCTOR, SMT, 0402, 12nH, ±5%, 500mA, 250MHz	LQW15AN12NJ00	MURATA
21	C46-C48, C392	4	CAPACITOR, SMT, 0402, CERAMIC, 2.0pF, 50V, ±0.25pF, C0G(NP0)	GRM1555C1H2R0CZ01	MURATA
22	L2	1	Inductor, SMD, 0805, 2.2uH, 20%, 600mA, 50MHz	LQM21PN2R2MC0	MURATA
23	S1-S2	2	ULTRA-SMALL TACTILE SWITCH, SMT, 2P, SPST-NO, 1.2x3x2.5mm, 0.05A, 12V	B3U-1000P	OMRON
24	R1, R7, R551, R554	4	RESISTOR/JUMPER, SMT, 0402, 0 Ω, 5%, 1/16W	ERJ-2GE0R00X (UN)	PANASONIC
25	R2-R3, R6	3	RESISTOR, SMT, 0402, THICK FILM, 5%, 1/16W, 330	ERJ-2GEJ331	PANASONIC
27	C511	1	CAPACITOR, SMT, 0402, CER, 2200pF, 50V, 10%, X7R	ECJ-0EB1H222K	PANASONIC
28	C111, C251, C521, C561	4	CAPACITOR, SMT, 0603, CERAMIC, 1uF, 6.3V, 20%, X5R	ECJ-1VB0J105K	PANASONIC
28a	C041	1	CAP CERAMIC 4.7UF 6.3V X5R 0603	ECJ-1VB0J475M	PANASONIC
29	R441	1	RESISTOR, SMT, THICK FILM, 56K, 1/16W, 1%	ERJ-2RKF5602	PANASONIC
30	X1	1	SMA STRIGHT JACK, SMT	32K10A-40ML5	ROSENBERGER
31	U1	1	DUT, SMT, PQFP, RGC-64, 0.5mmLS, 9.15x9.15x1mm, THRM.PAD	CC430F6147	TI

Table B-41. EM430F6147RF900 Bill of Materials (continued)

Pos.	Ref Des	No. per Board	Description	Part No.	Manufacturer
33	U2	1	IC, Step Down Converter with Bypass Mode for Low Power Wireless	TPS62370	TI
34	JP1	1	Pin Connector 2x4pin	61300821121	WUERTH
35	JP2, JP6, JP8	3	Pin Connector 1x3pin	61300311121	WUERTH
36a	JP3, JP5, JP9, JP10	4	Pin Connector 1x2pin	61300211121	WUERTH
38	JP1a	1	Pin Connector 2x3pin	61300621121	WUERTH
38	C7	1	Capacitor, Ceramic, 1206, 16V, X5R, 20%	GRM31CR61C226ME15L	MURATA
38	C8-9	2	CAP, SMD, Ceramic, 0402, 2.2uF, X5R	GRM155R60J225ME15D	MURATA
38	C041	1	CAP, SMD, Ceramic, 0603, 4.7uF, 16V, 10%, X5R		MURATA

B.41 MSP-FET

The MSP-FET is a powerful flash emulation tool to quickly begin application development on MSP430 microcontrollers.

The MSP-FET provides a USB interface to program and debug the MSP430 devices in-system through the JTAG interface or the pin-saving Spy-Bi-Wire (2-wire JTAG) protocol. Furthermore, the USB interface can be used for UART backchannel and MSP target BSL communication. UART and I²C BSL communication modes are supported.

The MSP-FET development tool supports development with all MSP430 devices and is designed for use with PCBs that contain MSP430 devices; for example, the MSP430 target socket boards.

B.41.1 Features

- USB debugging interface to connect a MSP430 MCU to a PC for real-time in-system programming and debugging
- Software configurable supply voltage between 1.8 V and 3.6 V at 100 mA
- Supports JTAG Security Fuse blow to protect code
- Supports all MSP430 boards with JTAG header
- Supports both JTAG and Spy-Bi-Wire (2-wire JTAG) debug protocols

B.41.2 Release Notes

The MSP-FET is supported by MSP Debug Stack ([MSPDS](#)) revision 3.4.0.20 and higher. Observe the following MSPDS-specific MSP-FET limitations.

B.41.2.1 MSPDS 3.4.0.20 Limitations

- EEM access to F149 and L092 devices is possible only when JTAG speed is set to slow.
- Poly Fuse Blow in Spy-Bi-Wire mode is in beta state and is not officially supported.
- The UART backchannel function is not implemented (even though an additional COM port is shown on the PC).

B.41.2.2 MSPDS UART Backchannel Implementation

In MSPDS v3.4.1.0 and later, the UART backchannel function is implemented and supported for the MSP-FET. The baud rates that are supported depend on the target configuration and the debug settings.

[Table B-42](#) shows which baud rates are supported with certain configuration combinations.

A green cell with ✓ means that the corresponding baud rate is supported without any data loss with the specified combination of settings.

A red cell with X means that the corresponding baud rate is not supported (data loss is expected) with the specified combination of settings.

Table B-42. UART Backchannel Implementation

Target MCLK Frequency:	1 MHz	1 MHz	8 MHz	8 MHz	1 MHz	1 MHz	8 MHz	8 MHz
Debugger:	Active	Active	Active	Active	Inactive	Inactive	Inactive	Inactive
Flow Control:	No	Yes	No	Yes	No	Yes	No	Yes
4800 baud	✓	✓	✓	✓	✓	✓	✓	✓
9600 baud	✓	✓	✓	✓	✓	✓	✓	✓
19200 baud	✓	✓	✓	✓	✓	✓	✓	✓
28800 baud	X	✓	✓	✓	✓	✓	✓	✓
38400 baud	X	✓	X	✓	X	✓	✓	✓
57200 baud	X	✓	X	✓	X	✓	X	✓
115200 baud	X	X	X	✓	X	X	X	✓

Figure B-82. MSP-FET Top View

Figure B-83. MSP-FET Bottom View

B.41.2.3 MSPDS UART Backchannel Activation Commands

The MSP-FET supports two different backchannel UART modes, one with flow control and one without. The different modes can be selected by opening the corresponding COM port with a dedicated baud rate. See [Table B-43](#) for the specific baud rates for each command.

NOTE: The baud rates used by these commands cannot be used for communication.

If none of the specified commands are transferred before setting the communication baud rate, communication starts with these default settings: 3.3-V target V_{CC} , no flow control mechanism.

Table B-43. UART Backchannel Activation Commands

Baud Rate	Command
9620	Set all backchannel UART pins to high impedance – no current flow into target device
9621	Configure backchannel UART communication without handshake (default start behavior)
9622	Configure backchannel UART communication with handshake
9623	Voltage configuration command. When this command is received, target V_{CC} is set to 3300 mV. After target V_{CC} is configured, it is switched through to the target device.

B.41.2.4 MSPDS MSP Target BSL Activation Commands

The MSP-FET can be used for communication with the target device BSL through the I²C and UART protocols. The activation of the different protocols is equivalent to the MSP-FET backchannel UART. See [Table B-44](#) for command details. In MSP-FET BSL communication mode, flow control is not available, because this is not supported by the MSP target device BSL.

UART BSL: The MSP-FET BSL UART mode supports the following baud rates: 9600, 14400, 19200, 28800, 38400, 56000, 57600, and 115200. For the BSL UART, 8 + 1 + even parity is used.

I²C BSL: The MSP-FET is always the I²C master, and the target device BSL is always the I²C slave. 7-bit I²C addressing mode is used with a fixed I²C slave address of 0x48.

NOTE: If the MSP-FET is configured to support BSL communication, debugger functionality is disabled. To switch to debugger mode, either perform a power cycle (unplug the USB cable) or configure the baud rate to 8001.

Table B-44. MSP Target BSL Activation Commands

Baud Rate	Command
9620	Set all UART or I ² C pins to high impedance – no current flow into target device
9601	BSL entry sequence and power up 3.3 V (UART BSL)
100000 or 100001	BSL entry sequence and power up 3.3 V (I ² C BSL)
400000 or 400001	BSL entry sequence and power up 3.3 V (I ² C BSL)
9623	Power up 3.3 V
8001	Activate debugger

B.41.3 Schematics

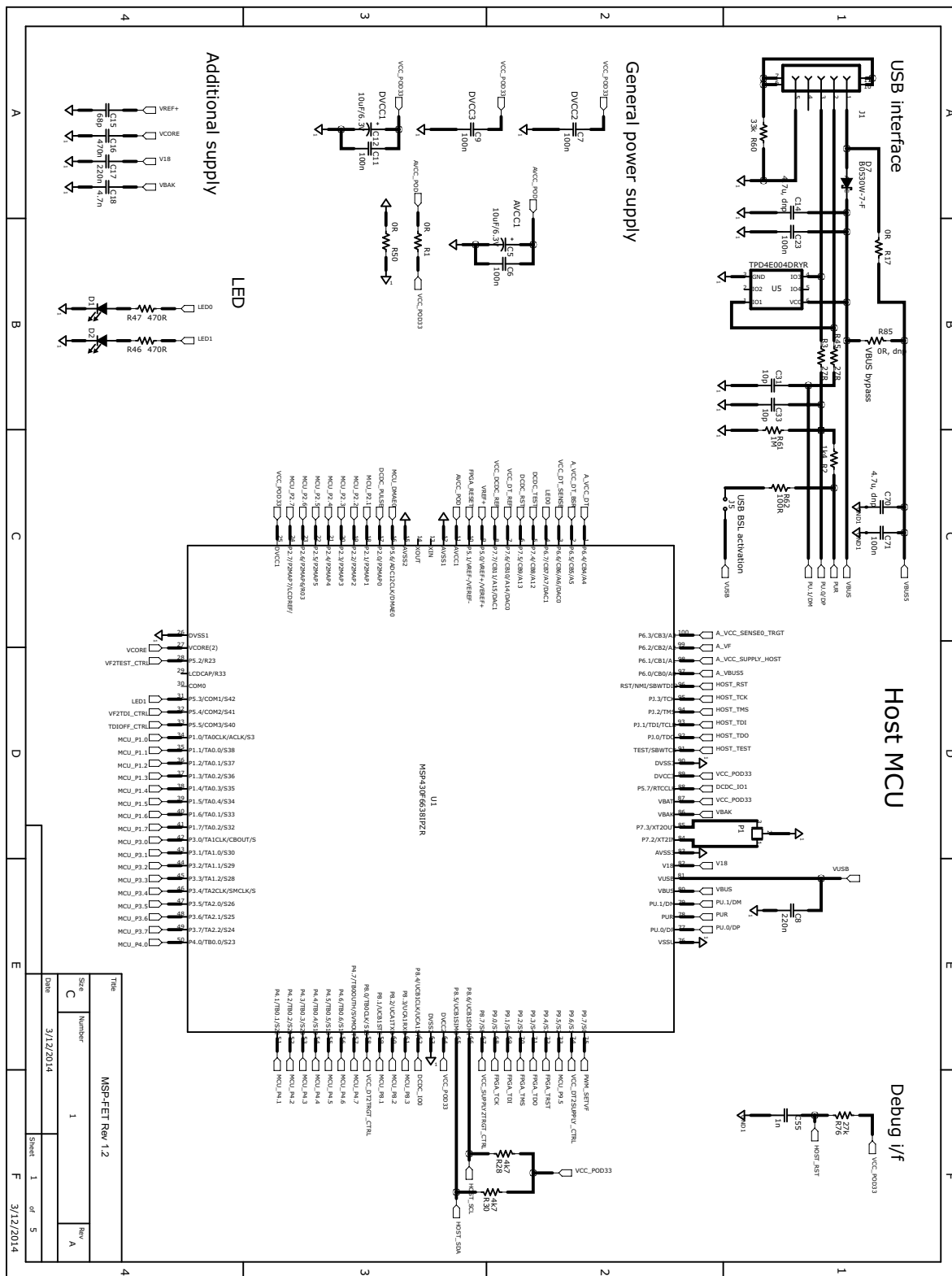

Figure B-84. MSP-FET USB Debugger, Schematic (1 of 5)

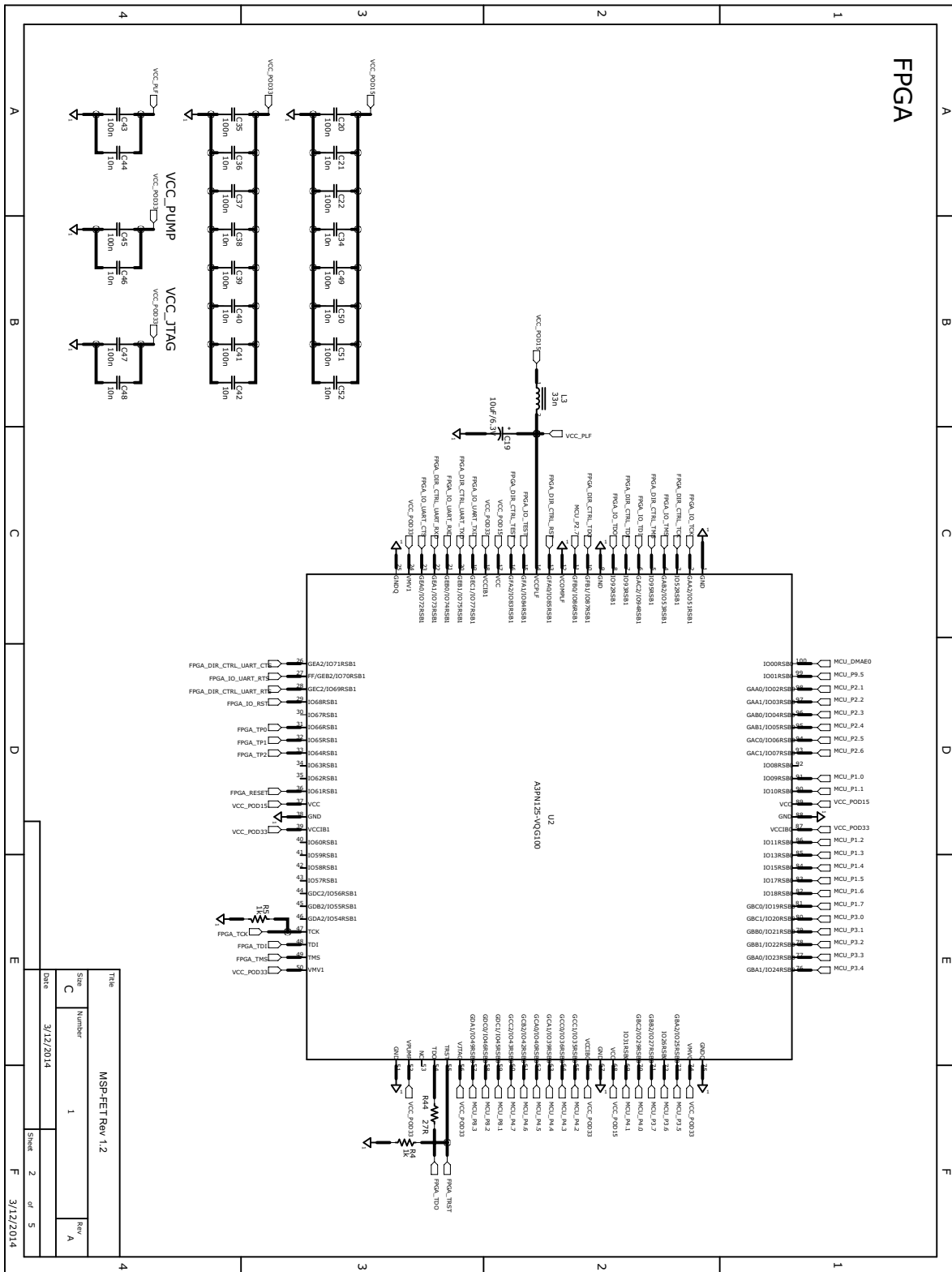

Figure B-85. MSP-FET USB Debugger, Schematic (2 of 5)

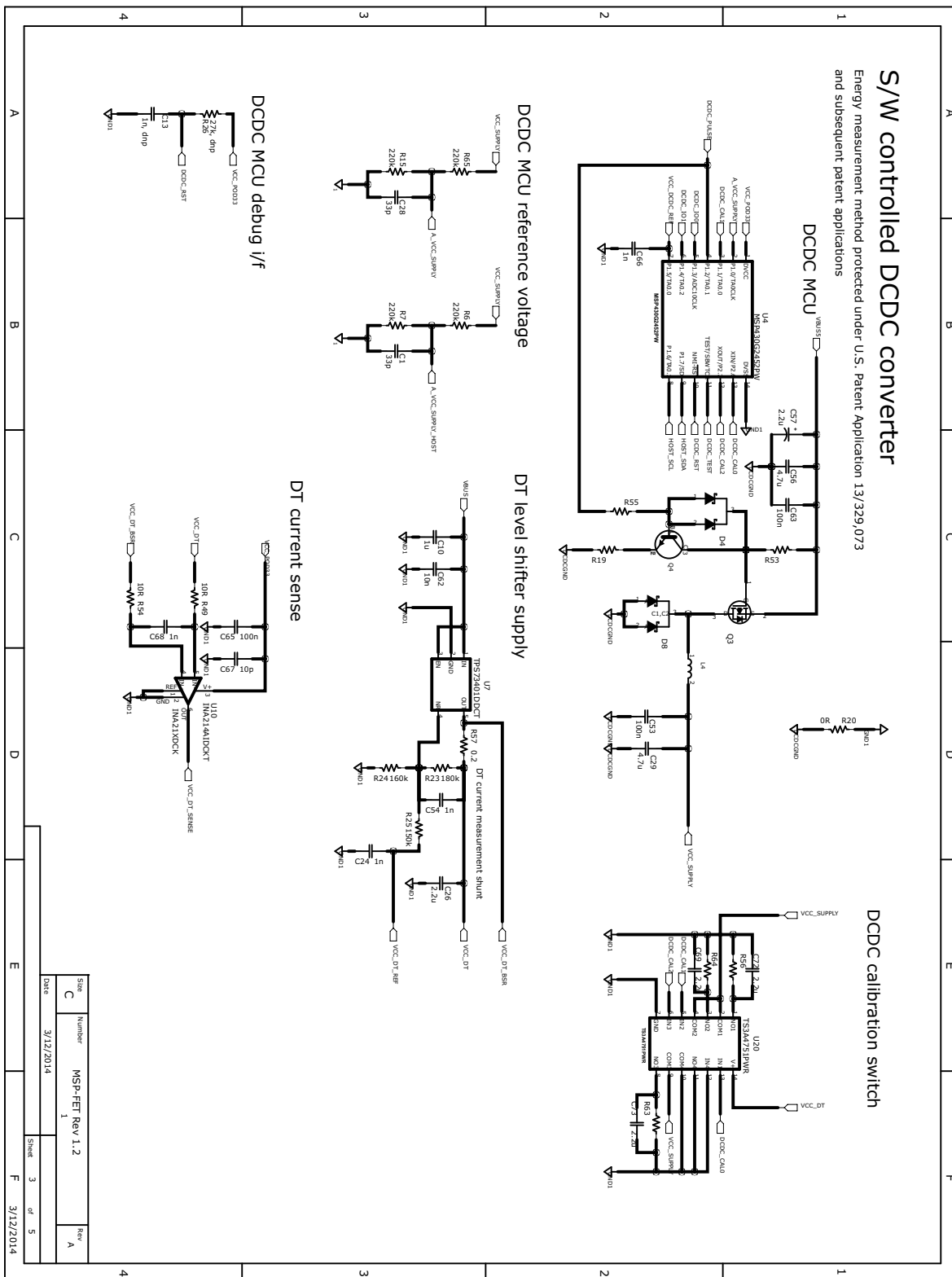

Figure B-86. MSP-FET USB Debugger, Schematic (3 of 5)

Sheet	Number	MSP-FET Rev 1.2	Sheet
C	1		A
Date	3/12/2014		
Sheet	3	of 5	
			3/12/2014

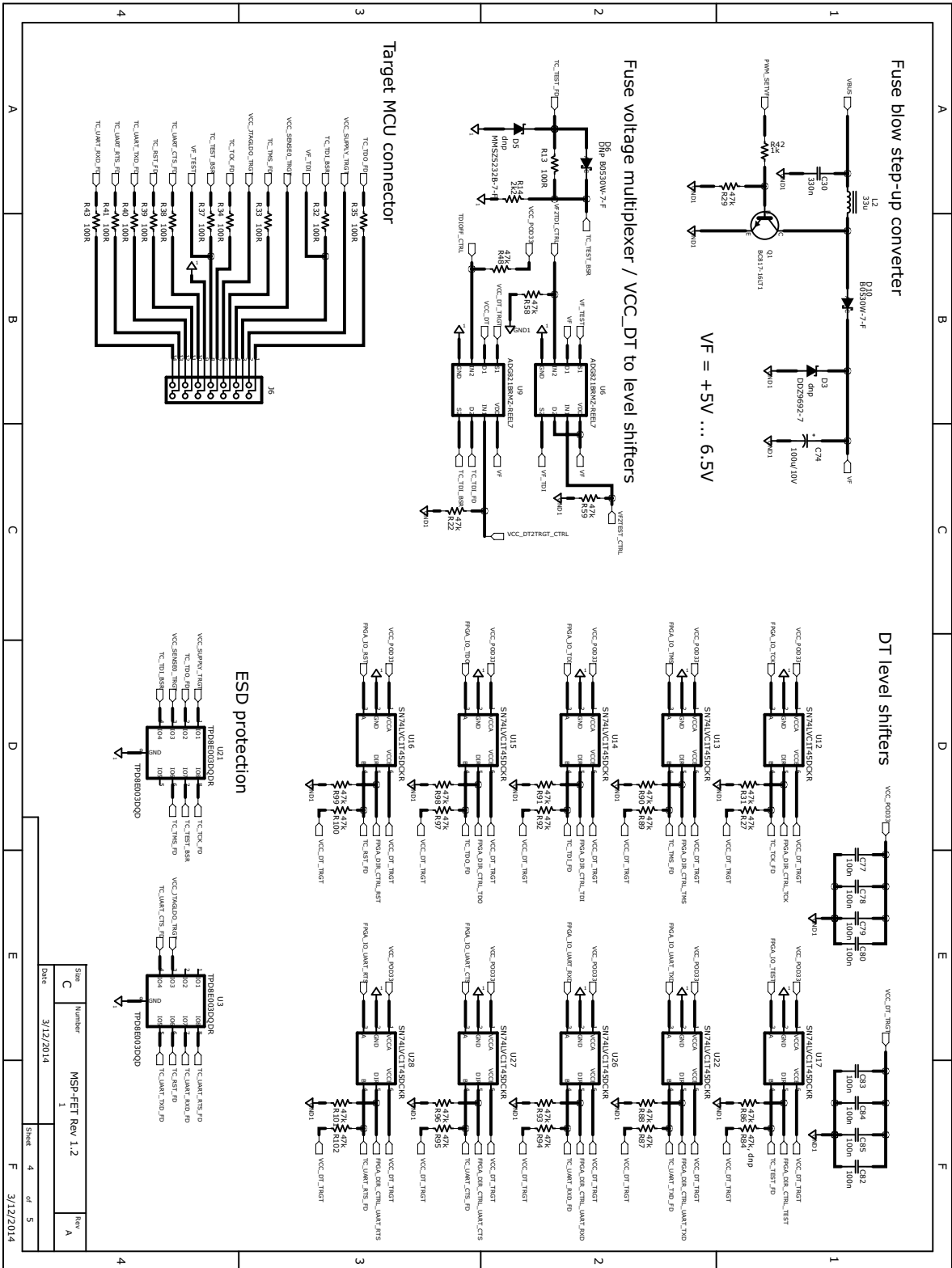

Figure B-87. MSP-FET USB Debugger, Schematic (4 of 5)

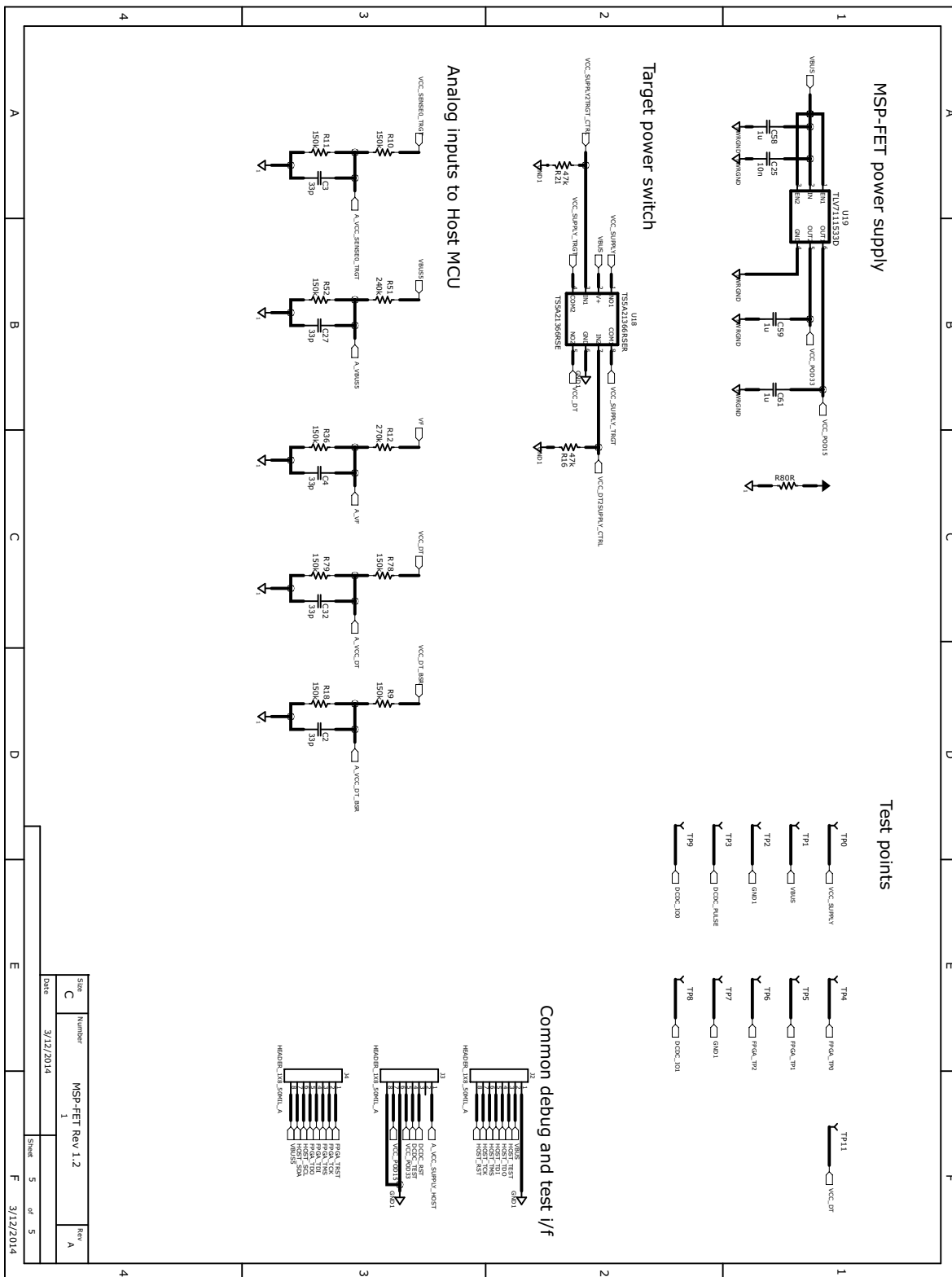

Figure B-88. MSP-FET USB Debugger, Schematic (5 of 5)

B.41.4 Layout

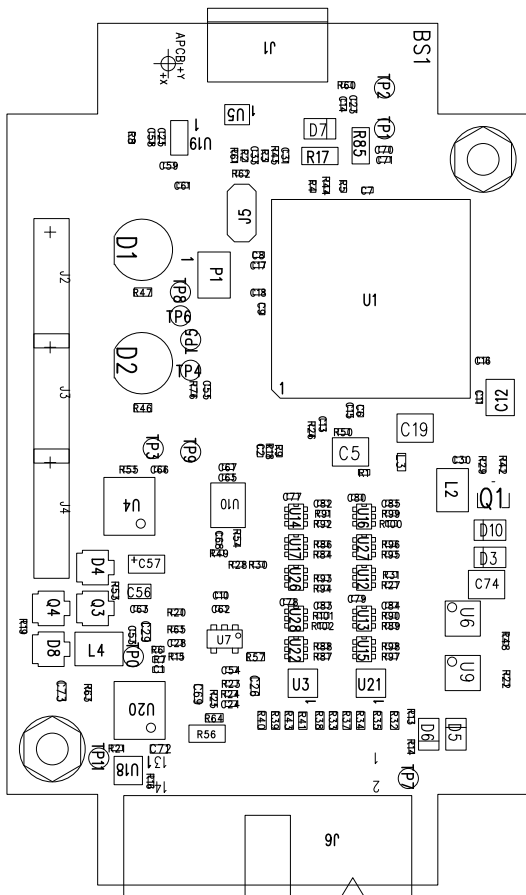

Figure B-89. MSP-FET USB Debugger, PCB (Top)

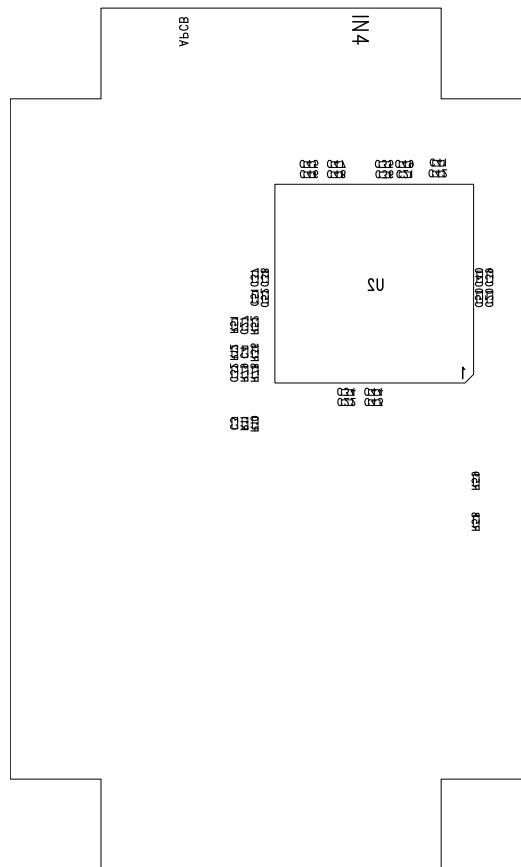

Figure B-90. MSP-FET USB Debugger, PCB (Bottom)

B.41.5 LED Signals





















The MSP-FET shows its operating states using two LEDs, one green and one red. Table B-45 lists all available operation modes. An  or  icon indicates that the LED is off, an  or  icon indicates that the LED is on, and an  or  icon indicates that the LED flashes.

Table B-45. MSP-FET LED Signals

Function	Power LED	Mode LED
MSP-FET not connected to PC, or MSP-FET not ready; for example, after a major firmware update. Connect or reconnect MSP-FET to PC.		
MSP-FET connected and ready		
MSP-FET waiting for data transfer		
Ongoing data transfer		
An error has occurred; for example, target V _{CC} overcurrent. Unplug MSP-FET from target, and cycle the power off and on. Check target connection, and reconnect MSP-FET.		
Firmware update in progress. Do not disconnect MSP-FET while both LEDs are blinking.		
FPGA update in progress. Do not disconnect MSP-FET while both LEDs are blinking rapidly.		

B.41.6 JTAG Target Connector

Figure B-91 shows the pinout of the JTAG connector.

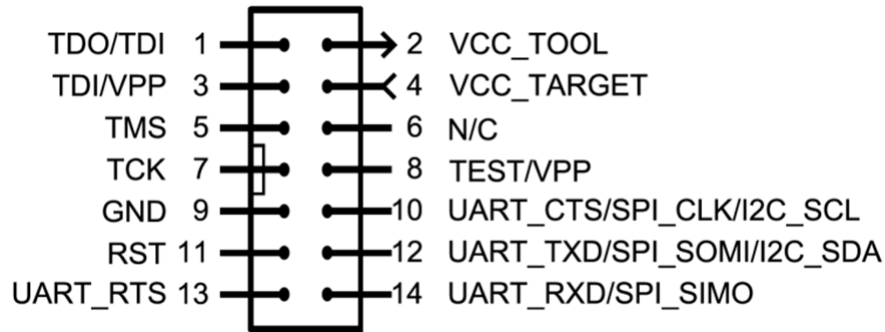

Figure B-91. JTAG Connector Pinout

Table B-46. JTAG Connector Pin State by Operating Mode

Pin	Name	After Power-Up	When JTAG Protocol is Selected	When Spy-Bi-Wire Protocol is Selected
1	TDO/TDI	Hi-Z, pulled up to 3.3 V	In, TDO	In and Out, SBWTDIO
2	VCC_TOOL	3.3 V	V _{CC}	V _{CC}
3	TDI/VPP	Hi-Z, pulled up to 3.3 V	Out, TDI	Hi-Z, pulled up to V _{CC}
4	VCC_TARGET	In, external V _{CC} sense	In, external V _{CC} sense	In, external V _{CC} sense
5	TMS	Hi-Z, pulled up to 3.3 V	Out, TMS	Hi-Z, pulled up to V _{CC}
6	N/C	N/C	N/C	N/C
7	TCK	Hi-Z, pulled up to 3.3 V	Out, TCK	Out, SBWTCK
8	TEST/VPP	Out, Gnd	Out, TEST	Hi-Z, pulled up to V _{CC}
9	GND	Ground	Ground	Ground
10	UART_CTS/SPI_CLK/I2C_SCL	Hi-Z, pulled up to 3.3 V	Out, Target UART Clear-To-Send Handshake input	Out, Target UART Clear-To-Send Handshake input
11	RST	Out, V _{CC}	Out, RST	Out
12	UART_TXD/SPI_SOMI/I2C_SDA	Hi-Z, pulled up to 3.3 V	In, Target UART TXD output	In, Target UART TXD output
13	UART_RTS	Hi-Z, pulled up to 3.3 V	In, Target UART Ready-to-Send Handshake output	In, Target UART Ready-to-Send Handshake output
14	UART_RXD/SPI_SIMO	Hi-Z, pulled up to 3.3 V	Out, Target UART RXD input	Out, Target UART RXD input

Figure B-92 shows the state of each pin in the connector after power-up.

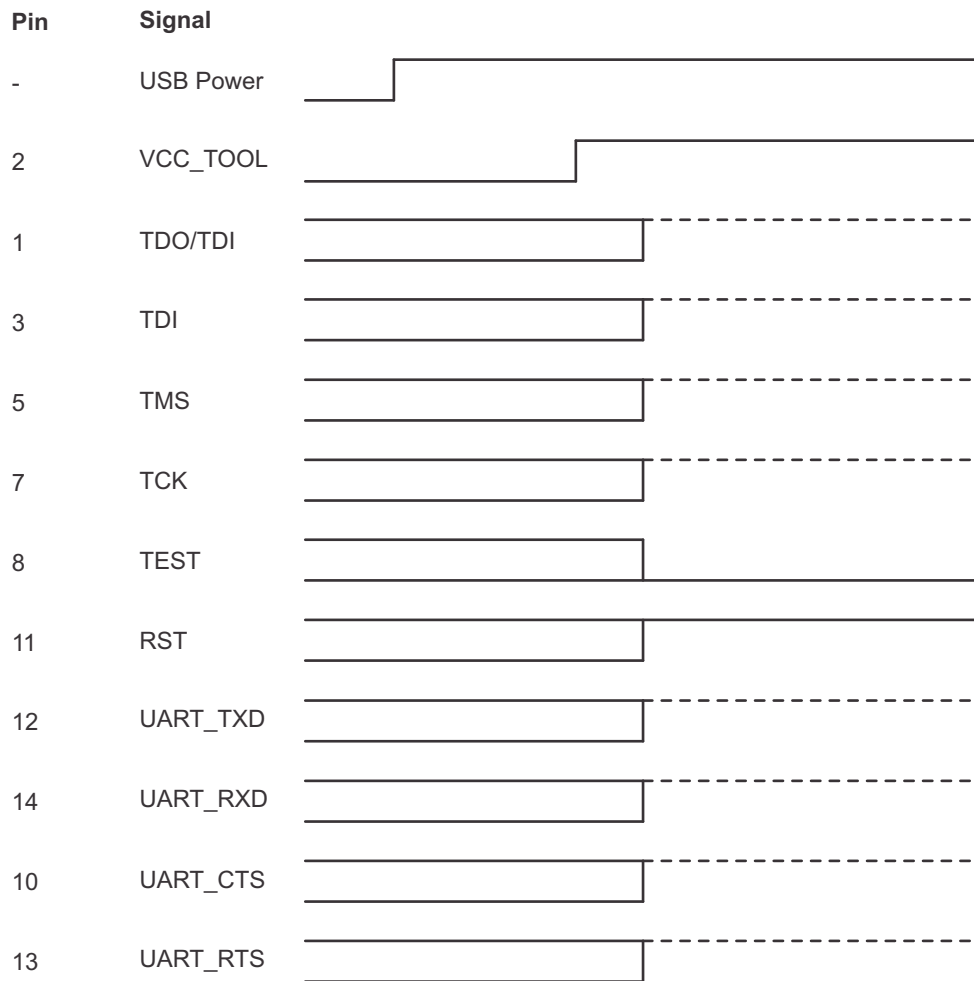

Figure B-92. Pin States After Power-Up

B.41.7 Specifications

Table B-47 shows the physical and electrical specifications of the MSP-FET.

Table B-47. Specifications

Mechanical		
Size (without cables)	80 mm x 50 mm x 20 mm	
Interfaces		
USB interface	USB 2.0, full speed	
Target interface	JTAG 14-pin	See Table B-46 for pinout
JTAG cable length	20 cm (max)	
JTAG and Spy-Bi-Wire Interface, Electrical		
Power supply	USB powered, 200 mA (max)	
Target output voltage VCC_TOOL	1.8 V to 3.6 V	Selectable in 0.1-V steps. VCC_TOOL available from JTAG pin 2.
Target output current	100 mA (max)	Current supplied through JTAG pin 2
Target output overcurrent detection level	160 mA (max)	
JTAG signal overcurrent detection level	30 mA (max)	Total current supplied through JTAG pins 1, 3, 5, 7, 8, 10, 11, 12, 13, 14
External target supply	Supported (1.8 V to 3.6 V)	Connect external target voltage VCC_TARGET to JTAG pin 4. JTAG and SBW signals are regulated to external target voltage ± 100 mV.
Fuse blow	Supported	For devices with poly-fuse
JTAG and Spy-Bi-Wire Interface, Timing		
JTAG clock speed	8 MHz (max)	Protocol speed selectable by software
Spy-Bi-Wire clock speed	8 MHz (max)	Protocol speed selectable by software. System limitations due to external RC components on reset pin (SBWTDIO) might apply.
JTAG and Spy-Bi-Wire Interface, Speed		
Flash write speed (JTAG)	Up to 20 kB/sec	
Flash write speed (Spy-Bi-Wire)	Up to 7 kB/sec	
FRAM write speed (JTAG)	Up to 50 kB/sec	
FRAM write speed (Spy-Bi-Wire)	Up to 14 kB/sec	
EnergyTrace™ Technology		
Target output current accuracy	$\pm 2\%$, ± 500 nA	For target output voltage = 1.8 V to 3.6 V, target output current <75 mA and USB voltage = 5 V constant during and after calibration

B.41.8 MSP-FET Revision History

Revision numbers are printed on the PCB and are stored in nonvolatile memory in firmware. Table B-48 shows the revision history of the MSP-FET.

Table B-48. MSP-FET Revision History

Revision	Date	Comments
Revision 1.2	March 2014	Initial release

B.42 MSP-FET430UIF

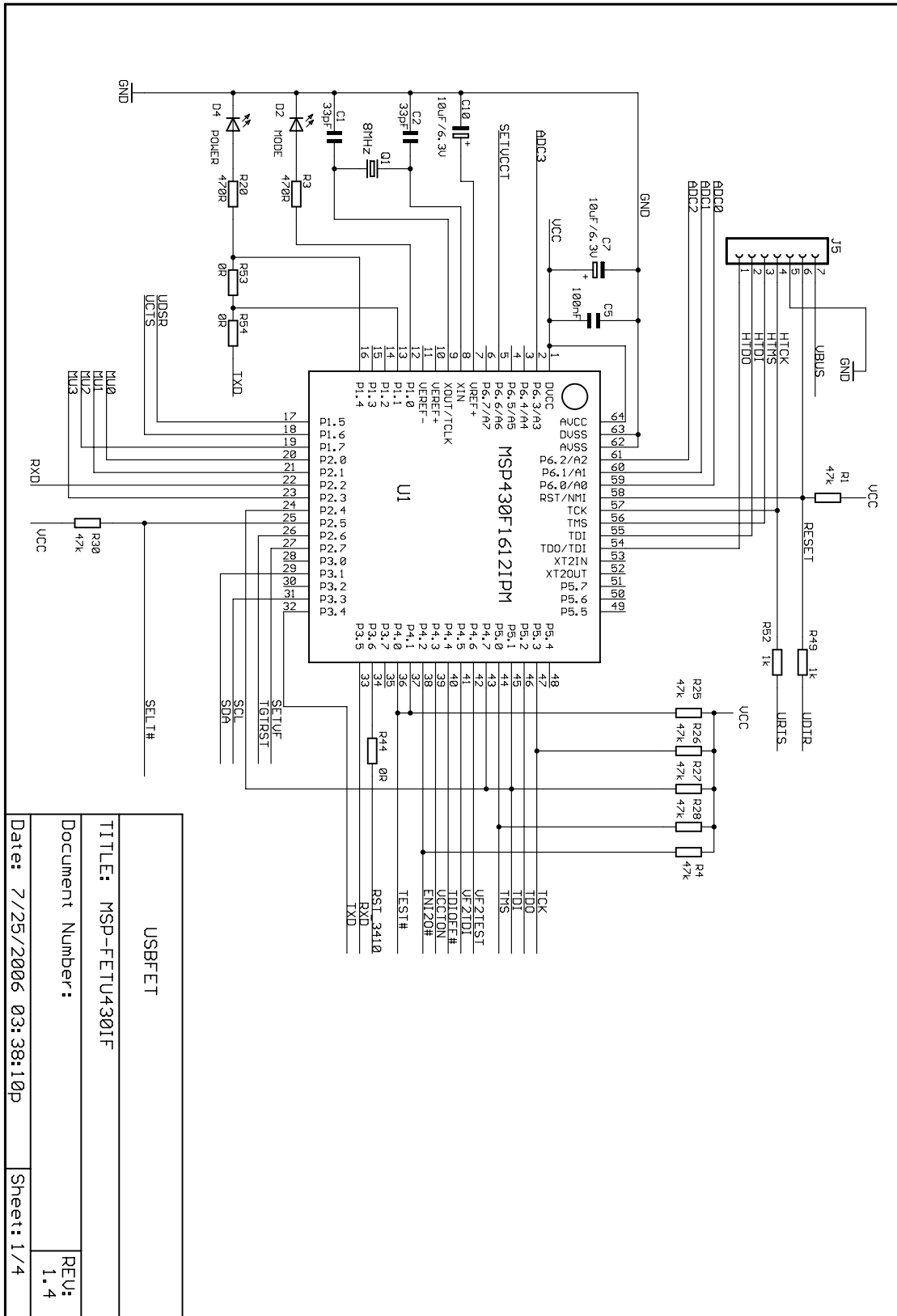

Figure B-93. MSP-FET430UIF USB Interface, Schematic (1 of 4)

USBFET

TITLE: MSP-FETU430IF

Document Number:

Date: 7/25/2006 03:38:10p

Sheet: 1/4

REV: 1.4

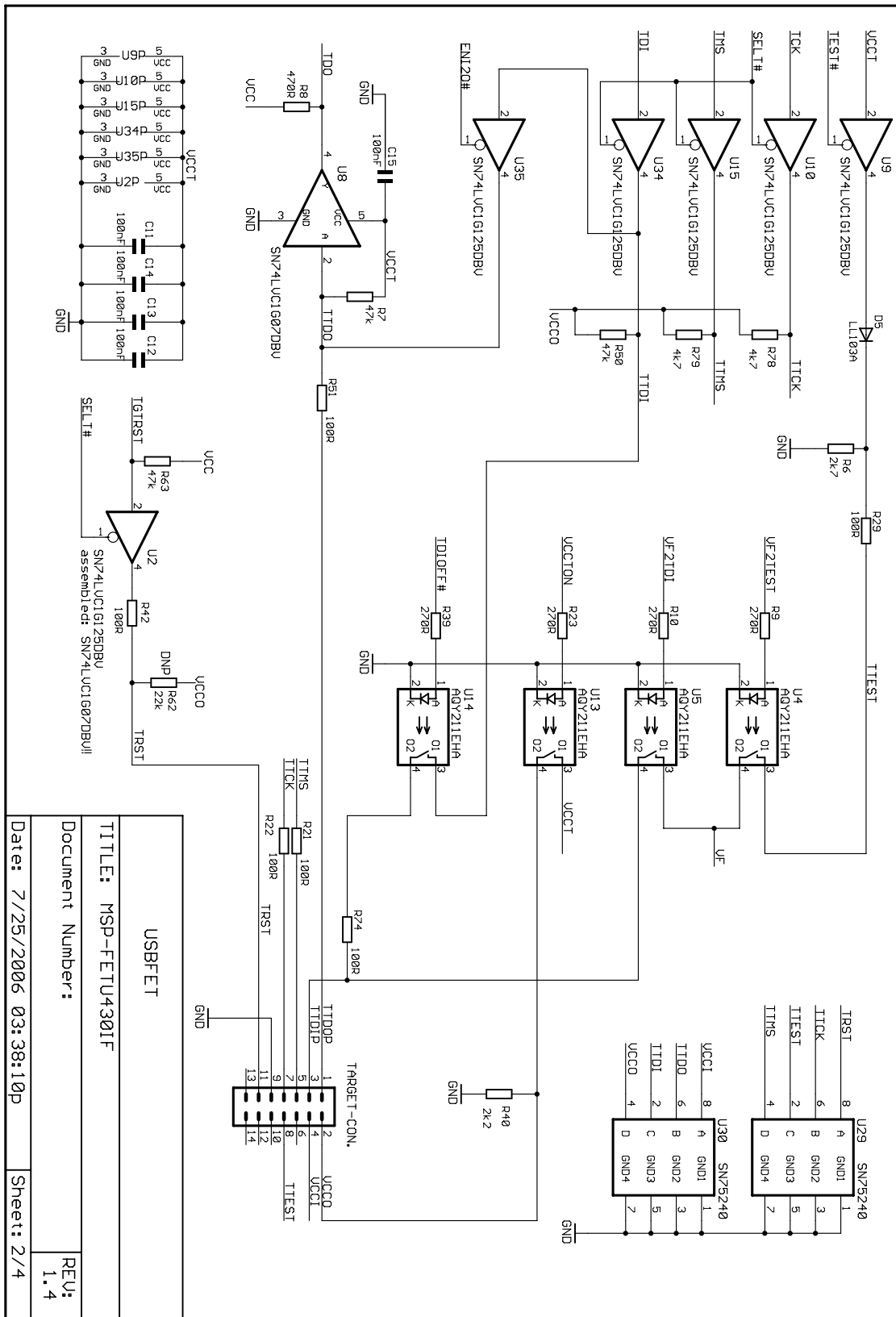

Figure B-94. MSP-FET430UIF USB Interface, Schematic (2 of 4)

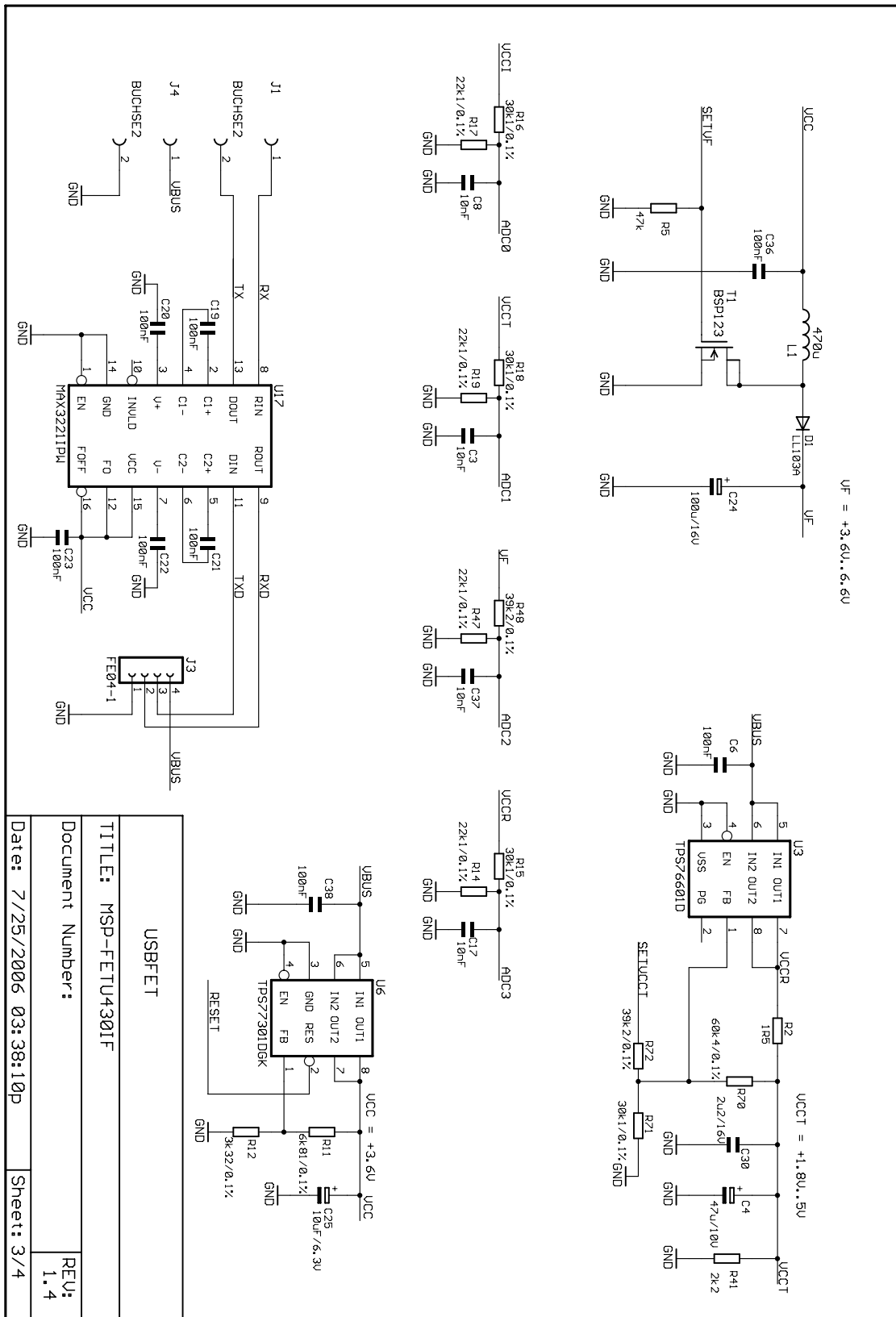

Figure B-95. MSP-FET430UIF USB Interface, Schematic (3 of 4)

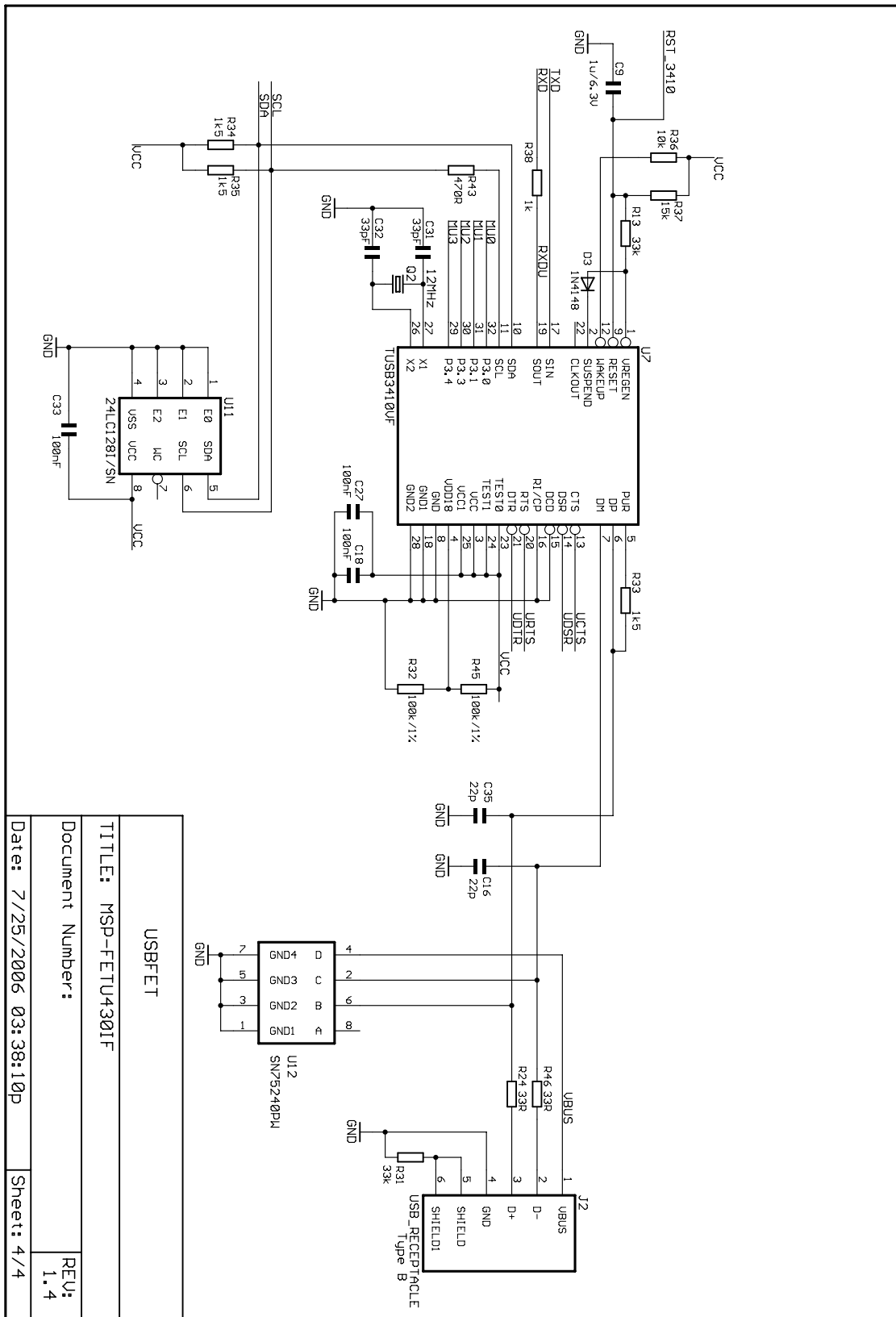

Figure B-96. MSP-FET430UIF USB Interface, Schematic (4 of 4)

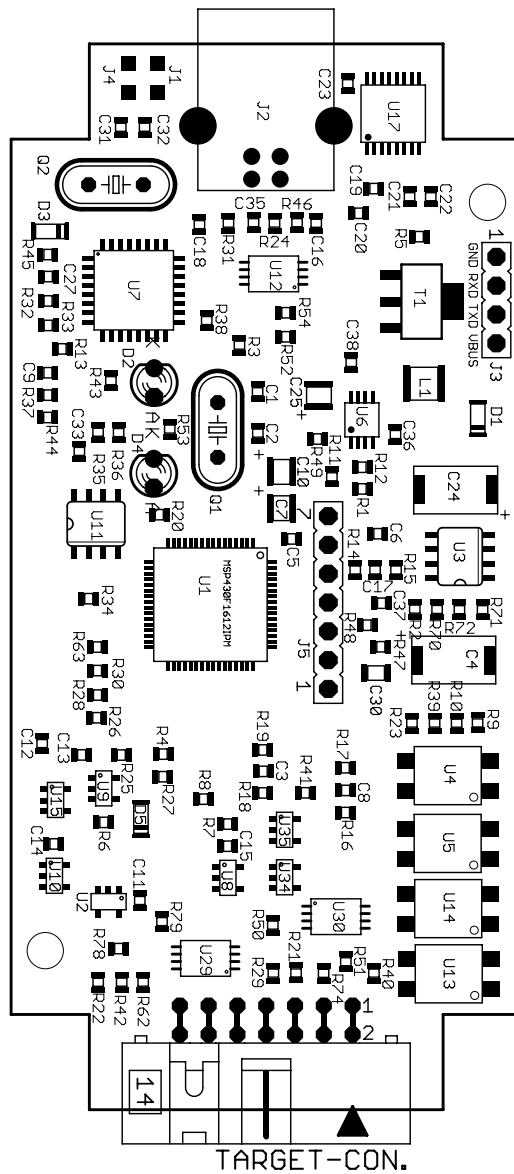

Figure B-97. MSP-FET430UIF USB Interface, PCB

B.42.1 MSP-FET430UIF Revision History

Revision 1.3

- Initial released hardware version

Assembly change on 1.3 (May 2005)

- R29, R51, R42, R21, R22, R74: value changed from 330R to 100R

Changes 1.3 to 1.4 (Aug 2005)

- J5: VBUS and RESET additionally connected
- R29, R51, R42, R21, R22, R74: value changed from 330R to 100R
- U1, U7: F1612 can reset TUSB3410; R44 = 0R added
- TARGET-CON.: pins 6, 10, 12, 13, 14 disconnected from GND
- Firmware-upgrade option through BSL: R49, R52, R53, R54 added; R49, R52 are currently DNP
- Pullups on TCK and TMS: R78, R79 added
- U2: Changed from SN74LVC1G125DBV to SN74LVC1G07DBV

NOTE: Using a locally powered target board with hardware revision 1.4

Using an MSP-FET430UIF interface hardware revision 1.4 with populated R62 in conjunction with a locally powered target board is not possible. In this case, the target device RESET signal is pulled down by the FET tool. It is recommended to remove R62 to eliminate this restriction. This component is located close to the 14-pin connector on the MSP-FET430UIF PCB. See the schematic and PCB drawings in this document for the exact location of this component.

Assembly change on 1.4a (January 2006)

- R62: not populated

B.43 MSP-FET430PIF

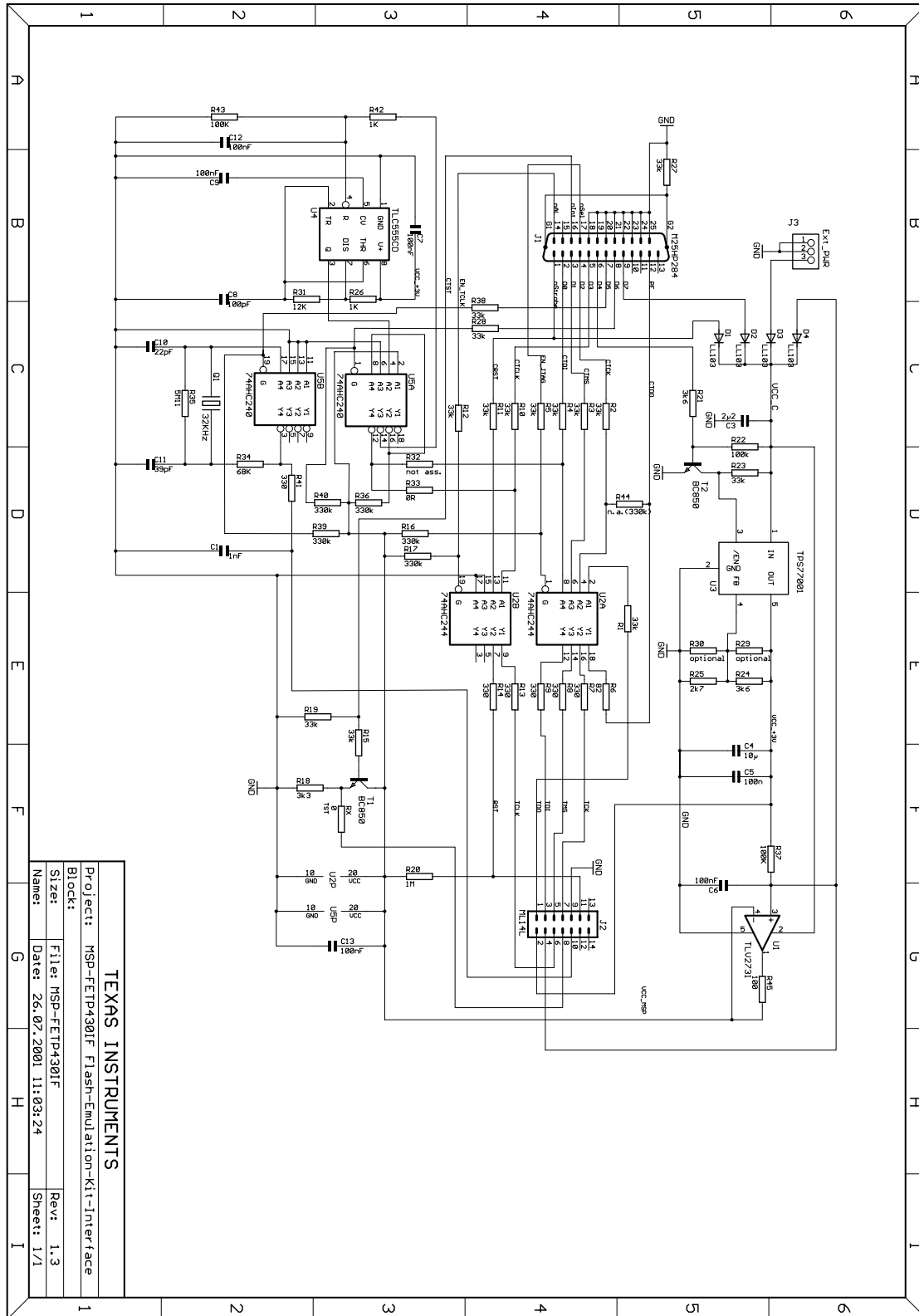

Figure B-98. MSP-FET430PIF FET Interface Module, Schematic

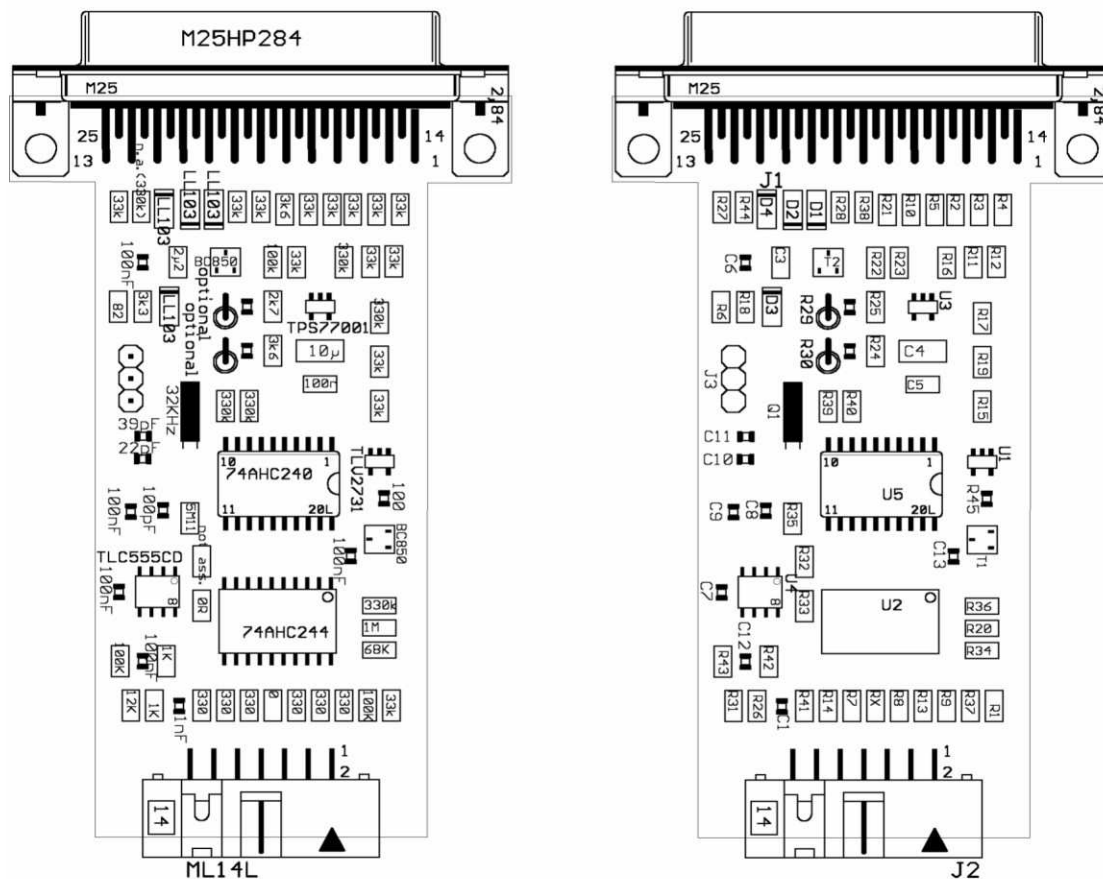

Figure B-99. MSP-FET430PIF FET Interface Module, PCB

Hardware Installation Guide

This section describes the hardware installation process of the following USB debug interfaces on a PC running Windows XP:

- MSP-FET430UIF
- eZ430-F2013
- eZ430-RF2500
- eZ430-Chronos
- eZ430-RF2780
- eZ430-RF2560
- MSP-WDSxx "Metawatch"
- LaunchPad (MSP-EXP430G2)
- MSP-EXP430FR5739
- MSP-EXP430F5529

The installation procedure for other supported versions of Windows is very similar and, therefore, not shown here.

Topic	Page
C.1 Hardware Installation	182

C.1 Hardware Installation

Table C-1 shows the USB VIDs and PIDs used in MSP430 tools.

Table C-1. USB VIDs and PIDs Used in MSP430 Tools

Tool	USB VID	USB PID	INF File Name
eZ430-F2013	0x0451	0xF430	usbuart3410.inf
eZ430-RF2500	0x0451	0xF432	430CDC.inf
eZ430-RF2780	0x0451	0xF432	430CDC.inf
eZ430-RF2560	0x0451	0xF432	430CDC.inf
MSP-WDSxx "Metawatch"	0x0451	0xF432	430CDC.inf
eZ430-Chronos	0x0451	0xF432	430CDC.inf
MSP-FET430UIF ⁽¹⁾	0x2047	0x0010	msp430tools.inf
MSP-FET	0x2047	0x0204	msp430tools.inf
eZ-FET	0x2047	0x0203	msp430tools.inf
LaunchPad (MSP-EXP430G2)	0x0451	0xF432	430CDC.inf
MSP-EXP430FR5739	0x0451	0xF432	430CDC.inf
MSP-EXP430F5529	0x0451	0xF432	430CDC.inf

⁽¹⁾ The older MSP-FET430UIF used with IAR versions before v5.20.x and CCS versions before v5.1 has VID 0x0451 and PID 0xF430. With the firmware update, it is updated to the 0x2047 and 0x0010, respectively.

1. Before connecting of the USB Debug Interface with a USB cable to a USB port of the PC the one of IDEs (CCS or IAR) should be installed. The IDE installation installs also drivers for USB Debug Interfaces without user interaction. After IDE installation the USB Debug Interface can be connected and will be ready to work within few seconds.
2. The driver can be also installed manually. After plug in the USB Debug Interface to USB port of the PC the Hardware Wizard starts automatically and opens the "Found New Hardware Wizard" window.
3. Select "Install from a list or specific location (Advanced)" (see Figure C-1).

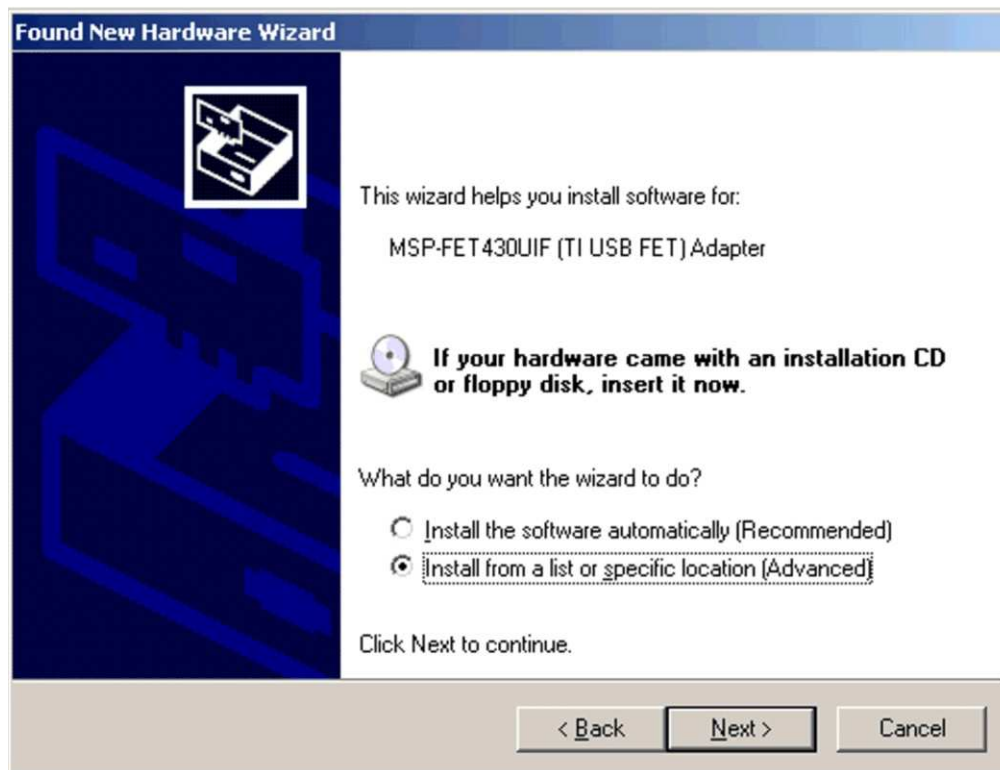

Figure C-1. Windows XP Hardware Wizard

4. Browse to the folder where the driver information files are located (see [Figure C-2](#)).
 For CCS, the default folder is: c:\ti\ccsv5\ccs_base\emulation\drivers\msp430\USB_CDC, or
 c:\ti\ccsv5\ccs_base\emulation\drivers\msp430\USB_FET_XP_XX, or
 c:\ti\ccsv5\ccs_base\emulation\drivers\msp430\USB_eZ-RF depending of firmware version of the tool.
 For IAR Embedded Workbench, the default folder is: <Installation Root>\Embedded Workbench
 x.x\430\drivers\TIUSBFET\Z430-UART, or
 <Installation Root>\Embedded Workbench x.x\430\drivers\<Win_OS>.

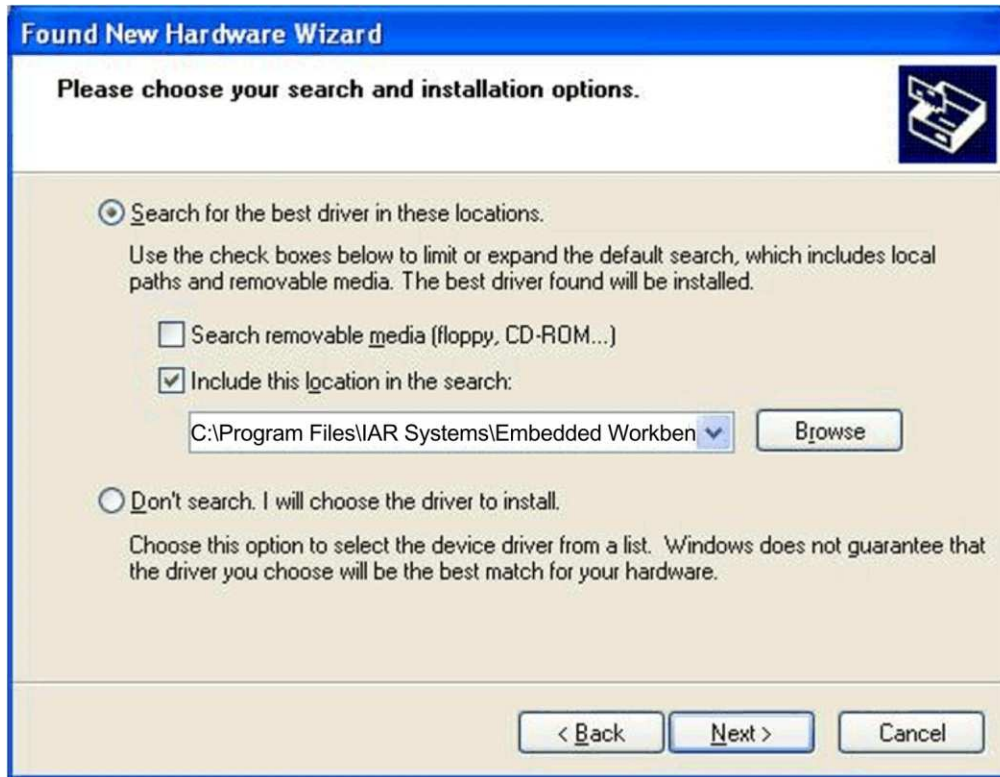

Figure C-2. Windows XP Driver Location Selection Folder

5. The Wizard generates a message that an appropriate driver has been found.

6. The wizard installs the driver files.
7. The wizard shows a message that it has finished the installation of the software USB Debug Interface.
8. The USB debug interface is installed and ready to use. The Device Manager lists a new entry as shown in [Figure C-3](#), [Figure C-4](#), or [Figure C-5](#).

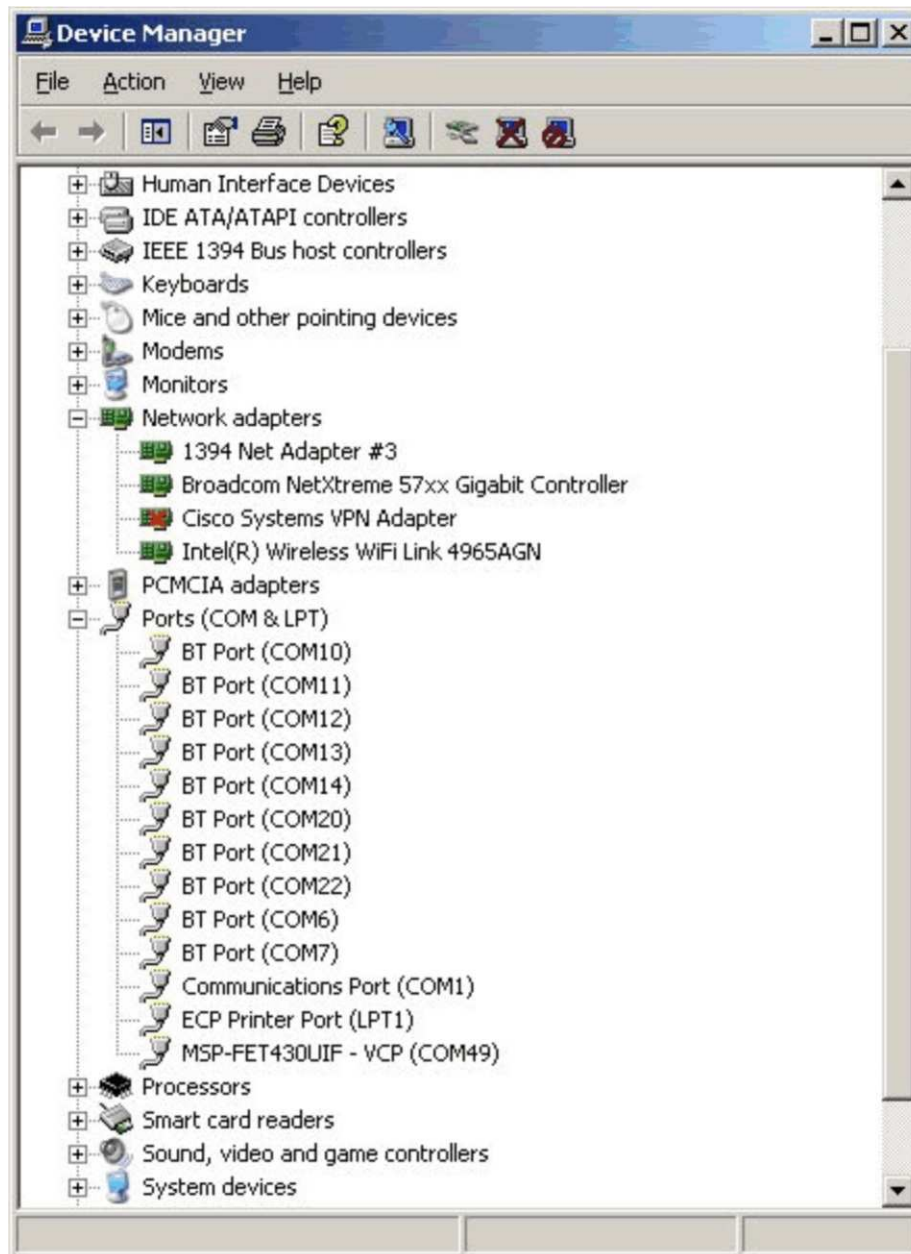

Figure C-3. Device Manager Using USB Debug Interface using VID/PID 0x2047/0x0010

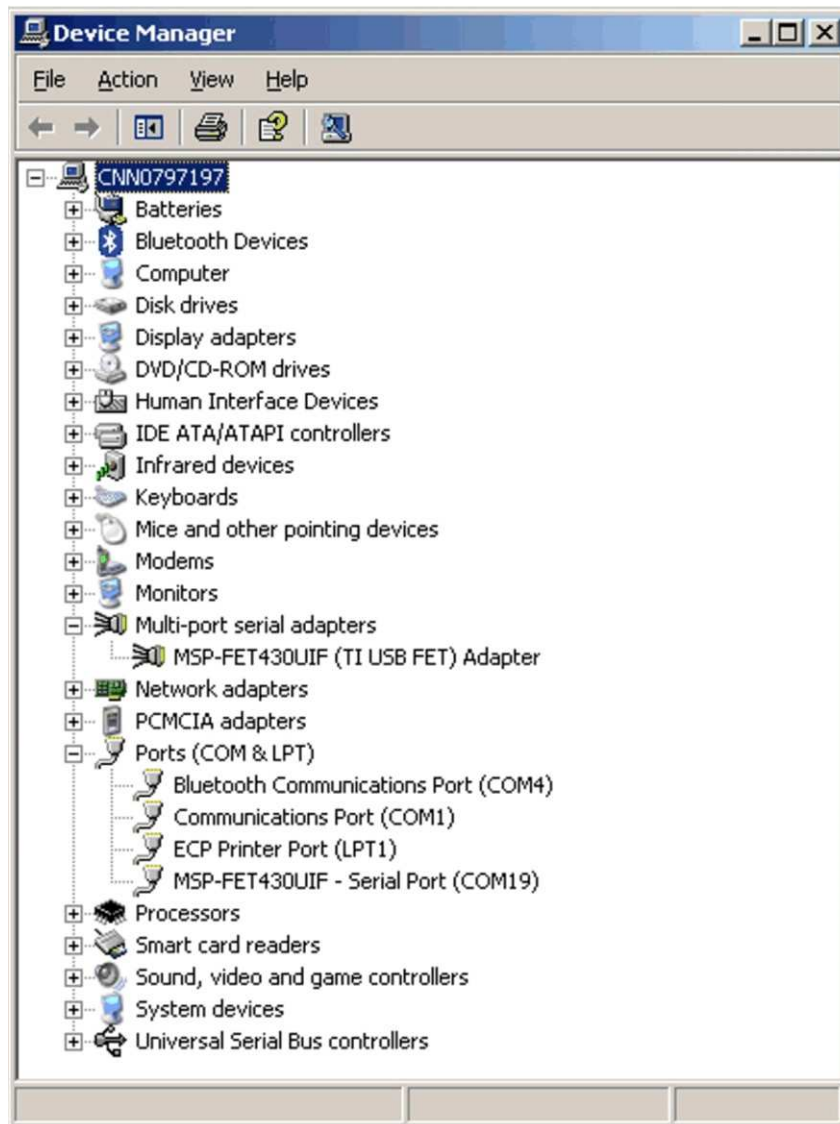

Figure C-4. Device Manager Using USB Debug Interface with VID/PID 0x0451/0xF430

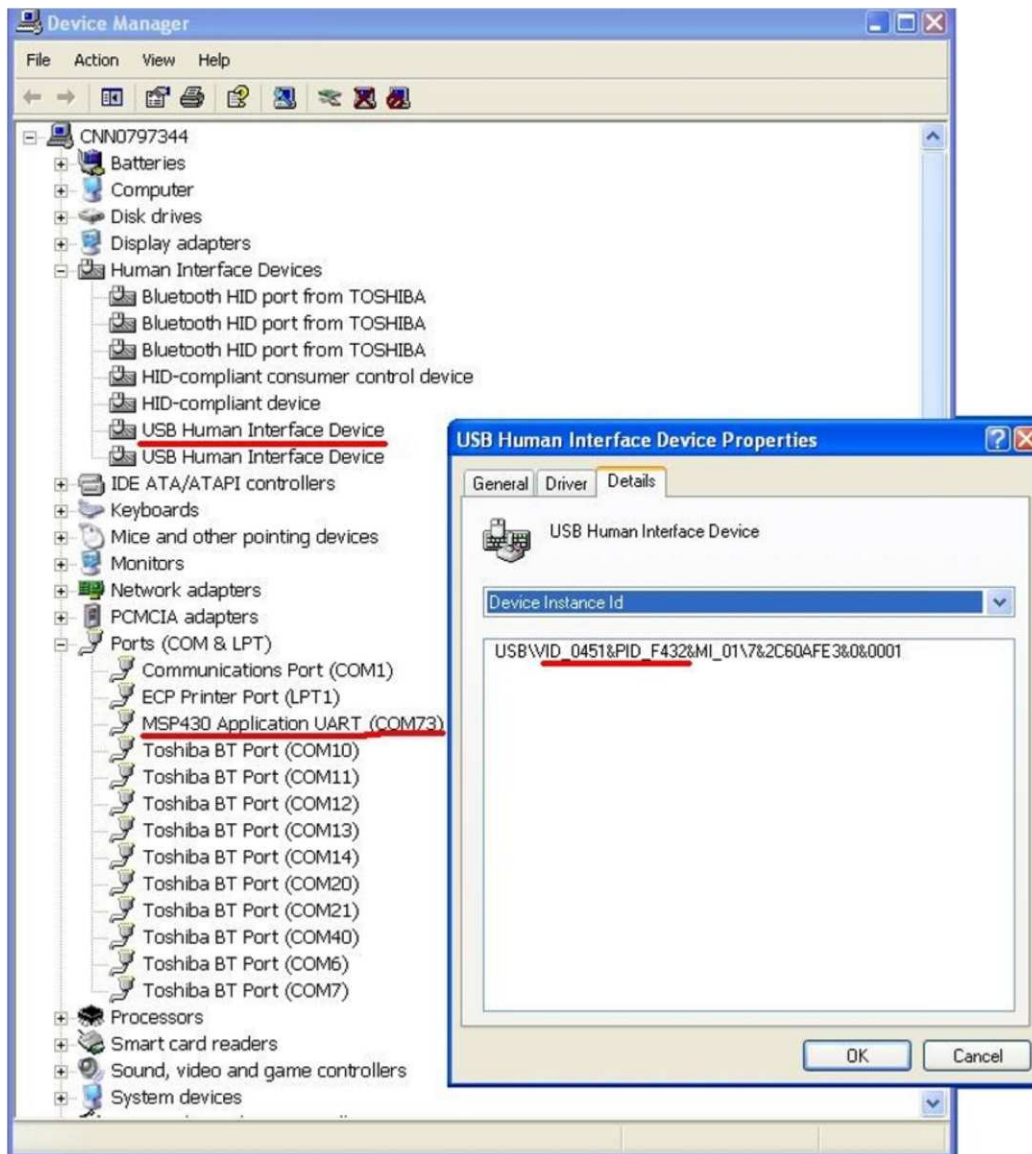

Figure C-5. Device Manager Using USB Debug Interface With VID/PID 0x0451/0xF432

Revision History

Changes from October 14, 2015 to February 12, 2016

Page

-
- Updated text, figures, and BOM for board revision 1.1 in [Section B.5](#), *MSP-TS430PW20*..... 44
-

NOTE: Page numbers for previous revisions may differ from page numbers in the current version.

IMPORTANT NOTICE

Texas Instruments Incorporated and its subsidiaries (TI) reserve the right to make corrections, enhancements, improvements and other changes to its semiconductor products and services per JESD46, latest issue, and to discontinue any product or service per JESD48, latest issue. Buyers should obtain the latest relevant information before placing orders and should verify that such information is current and complete. All semiconductor products (also referred to herein as "components") are sold subject to TI's terms and conditions of sale supplied at the time of order acknowledgment.

TI warrants performance of its components to the specifications applicable at the time of sale, in accordance with the warranty in TI's terms and conditions of sale of semiconductor products. Testing and other quality control techniques are used to the extent TI deems necessary to support this warranty. Except where mandated by applicable law, testing of all parameters of each component is not necessarily performed.

TI assumes no liability for applications assistance or the design of Buyers' products. Buyers are responsible for their products and applications using TI components. To minimize the risks associated with Buyers' products and applications, Buyers should provide adequate design and operating safeguards.

TI does not warrant or represent that any license, either express or implied, is granted under any patent right, copyright, mask work right, or other intellectual property right relating to any combination, machine, or process in which TI components or services are used. Information published by TI regarding third-party products or services does not constitute a license to use such products or services or a warranty or endorsement thereof. Use of such information may require a license from a third party under the patents or other intellectual property of the third party, or a license from TI under the patents or other intellectual property of TI.

Reproduction of significant portions of TI information in TI data books or data sheets is permissible only if reproduction is without alteration and is accompanied by all associated warranties, conditions, limitations, and notices. TI is not responsible or liable for such altered documentation. Information of third parties may be subject to additional restrictions.

Resale of TI components or services with statements different from or beyond the parameters stated by TI for that component or service voids all express and any implied warranties for the associated TI component or service and is an unfair and deceptive business practice. TI is not responsible or liable for any such statements.

Buyer acknowledges and agrees that it is solely responsible for compliance with all legal, regulatory and safety-related requirements concerning its products, and any use of TI components in its applications, notwithstanding any applications-related information or support that may be provided by TI. Buyer represents and agrees that it has all the necessary expertise to create and implement safeguards which anticipate dangerous consequences of failures, monitor failures and their consequences, lessen the likelihood of failures that might cause harm and take appropriate remedial actions. Buyer will fully indemnify TI and its representatives against any damages arising out of the use of any TI components in safety-critical applications.

In some cases, TI components may be promoted specifically to facilitate safety-related applications. With such components, TI's goal is to help enable customers to design and create their own end-product solutions that meet applicable functional safety standards and requirements. Nonetheless, such components are subject to these terms.

No TI components are authorized for use in FDA Class III (or similar life-critical medical equipment) unless authorized officers of the parties have executed a special agreement specifically governing such use.

Only those TI components which TI has specifically designated as military grade or "enhanced plastic" are designed and intended for use in military/aerospace applications or environments. Buyer acknowledges and agrees that any military or aerospace use of TI components which have **not** been so designated is solely at the Buyer's risk, and that Buyer is solely responsible for compliance with all legal and regulatory requirements in connection with such use.

TI has specifically designated certain components as meeting ISO/TS16949 requirements, mainly for automotive use. In any case of use of non-designated products, TI will not be responsible for any failure to meet ISO/TS16949.

Products

Audio	www.ti.com/audio
Amplifiers	amplifier.ti.com
Data Converters	dataconverter.ti.com
DLP® Products	www.dlp.com
DSP	dsp.ti.com
Clocks and Timers	www.ti.com/clocks
Interface	interface.ti.com
Logic	logic.ti.com
Power Mgmt	power.ti.com
Microcontrollers	microcontroller.ti.com
RFID	www.ti-rfid.com
OMAP Applications Processors	www.ti.com/omap
Wireless Connectivity	www.ti.com/wirelessconnectivity

Applications

Automotive and Transportation	www.ti.com/automotive
Communications and Telecom	www.ti.com/communications
Computers and Peripherals	www.ti.com/computers
Consumer Electronics	www.ti.com/consumer-apps
Energy and Lighting	www.ti.com/energy
Industrial	www.ti.com/industrial
Medical	www.ti.com/medical
Security	www.ti.com/security
Space, Avionics and Defense	www.ti.com/space-avionics-defense
Video and Imaging	www.ti.com/video

TI E2E Community

e2e.ti.com