

# AIRPAX

## AP/UP, AP/MIL Magnetic Circuit Protectors

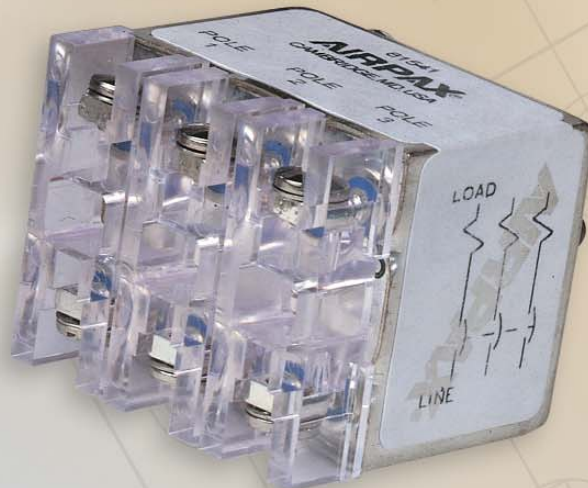



Single Pole Circuit Protectors	55
Multi-Pole Circuit Protectors	56
Configurations	58
Operating Characteristics	59
Delay Curves	60
Specifications	61
Decision Tables	62

# SINGLE POLE CIRCUIT PROTECTORS

The AP fully sealed, magnetic circuit protector combines power switching and accurate, reliable circuit protection with inverse time delays and trip free features.

Unlike a thermal circuit protector, the AP does not change its trip current over a wide temperature span. In addition, the AP magnetic circuit protector is available in either DC, 50/60Hz or 400Hz versions and with various delays to match the protector to specific application requirements.

One of the most important features of this protector is the "trip free" action, which means the circuit will not remain closed in the presence of an overload even though the handle is held in the ON position. The delay mechanism senses the fault and the contacts open.

Waterproof panel integrity is provided by an "O" ring bushing seal and a silicon rubber gland within the bushing/handle assembly.

Typical applications include communication, navigation and aircraft instrumentation, radar and power supplies.

The UP circuit protector, with UL recognition and CSA certification, is essentially the same as the AP in construction and operating principle. It is approved for operation at 50 volts DC to 20 amperes, 120 volts 50/60Hz to 15 amperes and 240 volts 50/60Hz to 7.5 amperes. The UP circuit protector is available in single pole units only, due to UL and CSA creepage specifications and the wide glass terminals utilized.

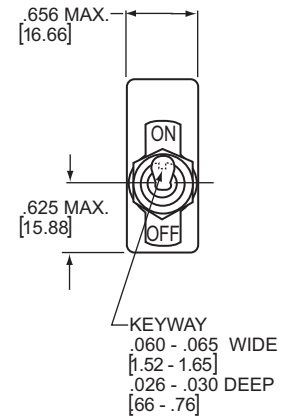
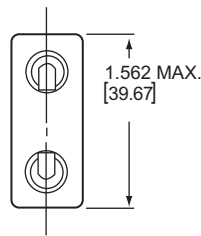
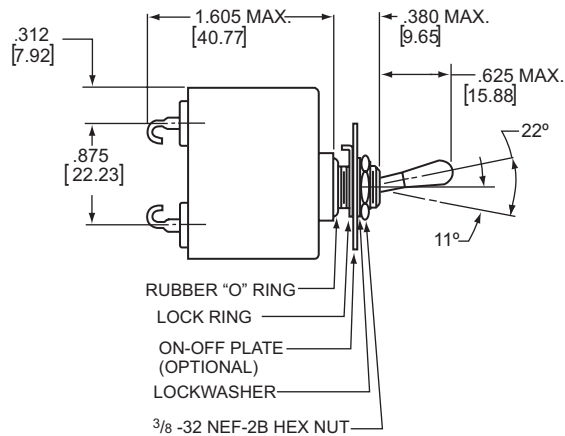

## Mounting Detail

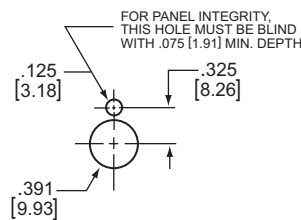

**Panel Mounting Detail:** Tolerance for Mtg.  $\pm .005$  [1.13]  
**Maximum Panel Thickness:** .156 [3.96]

AP/UP, AP/MIL

# MULTI-POLE CIRCUIT PROTECTORS

## AP Multi-Pole Combinations

Circuit demands and design ingenuity suggest a limitless number of special combinations, ranging from a two pole unit with one series protector and a simple ON-OFF switch, to a more complex three pole unit having one series, one shunt and one relay configuration with auxiliary indicator circuit contacts. Please contact Airpax for specific part number.

### Two Pole, AP12

Two of the basic units are combined in a sealed case to provide protection for dual circuit. A single toggle handle actuates both internal trip mechanisms. Conversely, an overload in either circuit trips both simultaneously.

The AP12 consists of two independent series trip protectors, each available with its own rating and delay characteristics.

This two pole unit can therefore have an unlimited number of combinations, which makes ordering by a code system impractical. Thus, if the poles differ, a descriptive drawing is recommended.

One frequent use of two pole protectors is to interrupt either or both sides of a power line. Likewise, three pole protectors often use three identical coils. However, any two or three pole protector may have any coil of any delay in any desired combination. (Unless otherwise specified, we assume the two or three poles to be all alike.)

All multi-pole units have provisions for a rugged three point panel mount. Use of 6-32 panel seal screws together with the bushing mount is recommended to maintain specification shock and vibration levels.

### Two Pole, AP12, Toggle

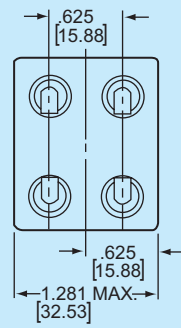
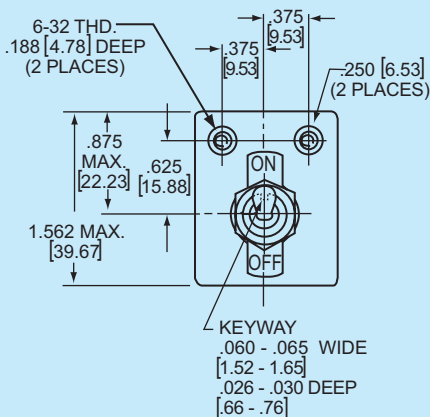
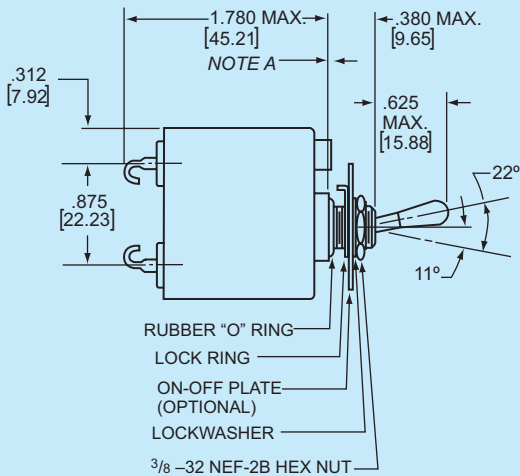

### Mounting Detail

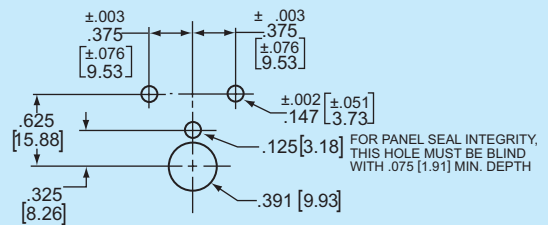

**Panel Mounting Detail:** Tolerance for Mtg. ±.005 [.13]  
**Panel Thickness:** .125-.156 [3.18-3.96]

**Note:** Tolerance ± .031 [.79] Angles: ±5° unless noted. Dimensions in brackets [ ] are millimeters.  
**A:** Threaded inserts exceed seated height of bushing by .005-.015 [.13-.38]

### Three Pole, AP112

Three circuits may be simultaneously protected. One actuating toggle handle closes all circuits and all poles trip in the presence of an overload on any circuit. Some typical combinations could be: 3 series poles; 2 series and one shunt; 2 series and one relay; or 3 series with a set of auxiliary contacts. Like the two pole protectors, each pole may have different ratings and delays.

exacting production and test program to maintain their Qualified Products Listing (QPL). One, two and three pole series trip units, with or without auxiliary contacts, have been accepted for this listing. Refer to specification sheets MIL-PRF-39019/1 through 6 for the application government designations.

### AP/MIL Circuit Protectors

Type AP-MIL protectors, produced in accordance with MIL-PRF-39019 and the pertinent specification sheets, are subjected to an

### Three Pole, AP112, Toggle

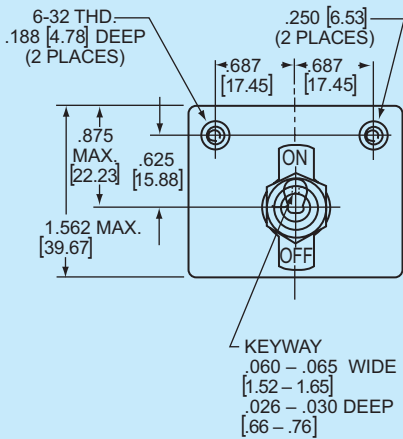
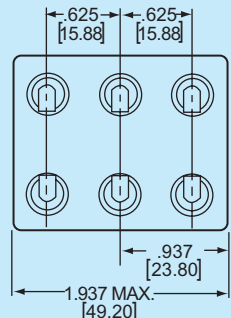
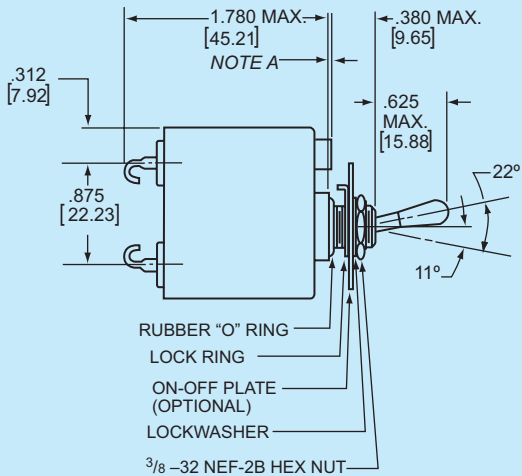

### Mounting Detail

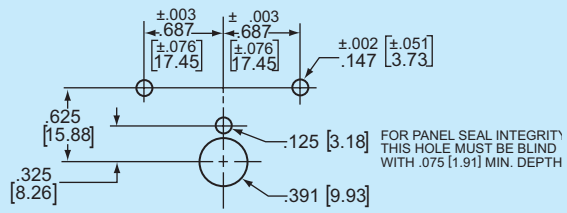

**Panel Mounting Detail:** Tolerance for Mtg. ±.005 [.13]  
**Panel Thickness:** .125-.156 [3.18-3.96]

## Series Trip

The most popular configuration for magnetic protectors is the series trip where the sensing coil and contacts are in series with the load being protected. The handle position conveniently indicates circuit status. In addition to providing conventional overcurrent protection, it's simultaneously used as a power disconnect.

## Shunt Trip

The shunt trip is designed for controlling two separate loads with one assembly. The control is established by providing overload protection for the critical load. When the current through this load becomes excessive and reaches the trip point the protector will open and remove power from both loads simultaneously. The total current rating of both loads must not exceed the maximum contact rating.

## Relay Trip

This permits the overload sensing coil to be placed in a circuit which is electrically isolated from the trip contacts. The coil may be actuated by sensors monitoring pressure, flow, temperature, speed, etc. Other typical applications include crowbar, interlock and emergency/rapid shutdown circuitry. Trip may be accomplished by voltage or current, which must be removed immediately upon tripping.

## Remote Indication, AP1-1R

AP series trip circuit protectors are available with electrically isolated contacts which are rated at 1/2 ampere, 120 volts AC or 50 volts DC. These contacts provide SPDT switching action which can be used to indicate "power-on" and "power-off" conditions or to actuate lights, alarms or timing devices.

## Voltage Trip

Sometimes called "dump circuits" or "panic trip circuits," these units make it possible to open main power contacts with lower power inputs from one or more sources. This configuration is becoming increasingly more important for sensitive circuitry and denser packaging in automation systems. Available in series, shunt or relay configurations.

### Series Trip AP1-1

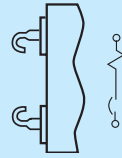

### Optional Booted Terminals

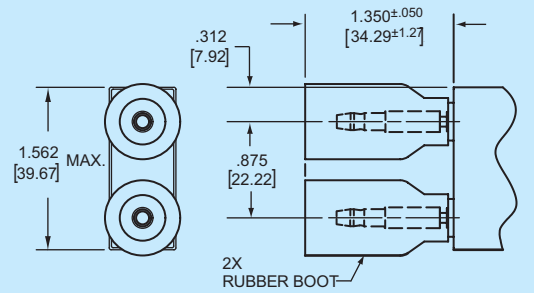

### UP1-1 (UL Recognized Series)

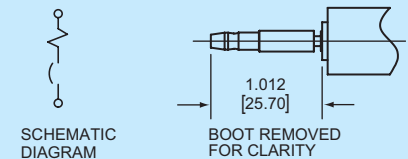
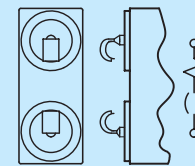

SCHEMATIC DIAGRAM

### Shunt Trip AP1-3

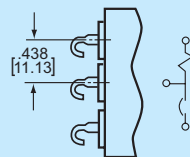

### Relay Trip (Note A) AP1-4 (Relay)

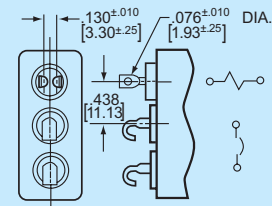

### Series with Auxiliary Switch AP1-1R (Note A)

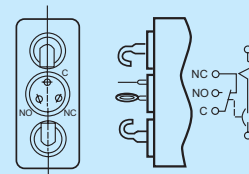

### Switch with Auxiliary Switch AP1-1RC (Note A)

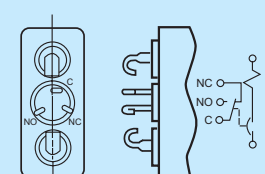

### AP7-1 (Screw Terminal with Terminal Block)

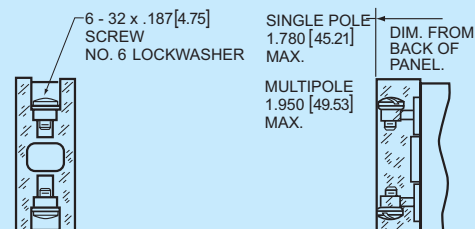

**Note:** Tolerance  $\pm .031$  [7.9] Angles:  $\pm 5^\circ$  unless noted.  
Dimensions in brackets [ ] are millimeters.  
**A.** Main protector contacts open.

# OPERATING CHARACTERISTICS

## Nominal Values of Series Resistance at +25° C

Current Ratings DC, 50/60, 400Hz in Amperes	DC Series Resistance All Delays Except 40, 50, 60	DC Series Resistance Delays 40, 50, 60
.050	470 ohms	105 ohms
.100	145 ohms	27.0 ohms
.250	18.0 ohms	3.80 ohms
.500	4.30 ohms	1.00 ohms
.750	1.60 ohms	.400 ohms
1.00	1.15 ohms	.230 ohms
2.00	.298 ohms	.060 ohms
3.00	.130 ohms	.033 ohms
5.00	.052 ohms	.012 ohms
7.50	.025 ohms	.007 ohms
10.0	.016 ohms	.006 ohms
15.0	.006 ohms	.005 ohms
20.0	.005 ohms	.004 ohms

**Note:** Tolerance at ±25% values based on V-A method after 1 hour stabilization at 100% rated current. Consult factory for other limits.

## Inrush Pulse Tolerance

The following table provides a comparison of inrush pulse tolerance with and without the inertial delay feature for each of the 50/60Hz delays. Pulse tolerance is defined as a single pulse of half sine wave peak current amplitude of 8 milli-seconds duration that will not trip the circuit protector.

Delay	Peak Amplitude
61, 62, 71, 72, A, B	4 Times Rated Current (60Hz)
61F, 62F, 71F, 72F	6.5 Times Rated Current (60Hz)
64, 65	10 Times Rated Current (60Hz)
64F, 65F	13 Times Rated Current (60Hz)
41, 42, AF, BF	14 Times Rated Current (400Hz)
41F, 42F	20 Times Rated Current (400Hz)
51, 52	6 Times Rated Current (60Hz)
51F, 52F, AF, BF	8 Times Rated Current (60Hz)

## Percentage of Rated Current vs. Trip Time in Seconds at 25°C in Vertical Mtg. Position

Delay	100%	125% (Note A)	200%	400%	800%
40*	No Trip	.035 Max.	.025 Max.	.015 Max.	.015 Max.
41	No Trip	.200 - 7	.055 - .950	.010 - .240	.005 - .080
42	No Trip	3 - 60	.500 - 9	.010 - 1.75	.005 - .100
49*	No Trip	.100 Max.	.050 Max.	.020 Max.	.015 Max.
50*	No Trip	.035 Max.	.025 Max.	.015 Max.	.015 Max.
51	No Trip	.400 - 4	.060 - .600	.010 - .200	.005 - .035
52	No Trip	4 - 40	.600 - 6	.010 - 1.50	.005 - .050
59*	No Trip	.100 Max.	.050 Max.	.020 Max.	.015 Max.
60*	No Trip	.035 Max.	.025 Max.	.015 Max.	.015 Max.
61	No Trip	.500 - 5	.070 - .700	.020 - .200	.008 - .080
62	No Trip	4 - 40	.800 - 8	.010 - .300	.005 - .080
64	No Trip	.900 - 10	.200 - 1.70	.040 - .500	.012 - .100
65	No Trip	9 - 60	1.15 - 7	.110 - 1	.010 - .190
69*	No Trip	.100 Max.	.050 Max.	.020 Max.	.015 Max.
71 (Note B)	No Trip	.200 - 7	.055 - .950	.010 - .240	.005-.080
72 (Note B)	No Trip	3 - 60	.500 - 9	.010 - 1.75	.005 - .100
79 (Note B)*	No Trip	.100 Max.	.050 Max.	.020 Max.	.015 Max.

\*Notes: Instantaneous delays (40, 49, 59, 60, 69, 79) are not compatible with inrush enhancement options and are not recommended for general use.  
 A. 150% for delays 40, 50 & 60. 135% minimum trip for delays 41, 42, 49, 71, 72 & 79.  
 B. Military time delays. 71=A, 72=B, 79=C

## Typical Delay Curves

The delay curves below illustrate our standard instant, short and long delays. Please consult factory for specific delay curves or refer to table on page 59.

Delay curves 64 and 65 illustrate the improved inrush tolerance provided compared to standard delays. Not available in MIL configurations.

All trip times and trip currents are specified with the protector mounted in the normal vertical position at ambient temperature of 25°C. For time delay test and measurement purposes, the protectors should not carry current prior to application of overload.

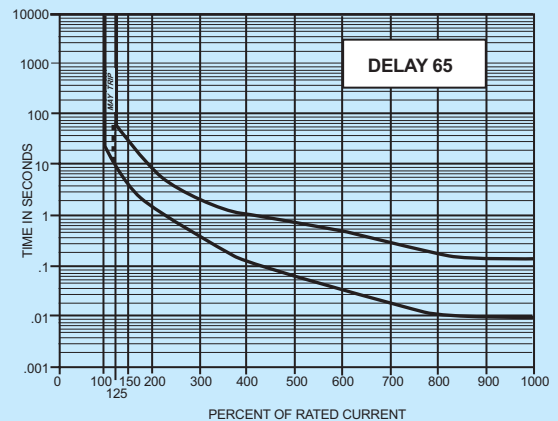
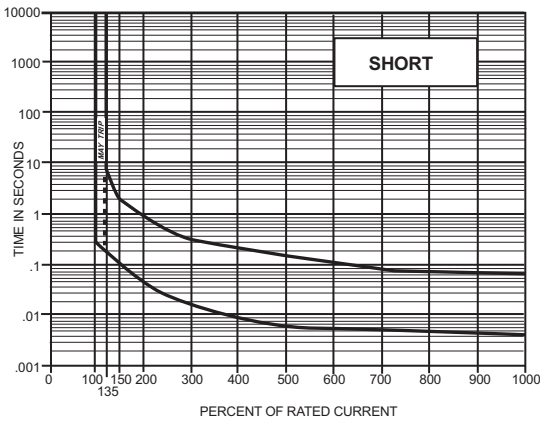
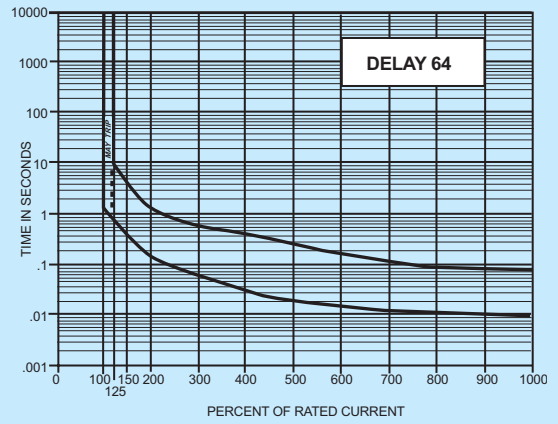
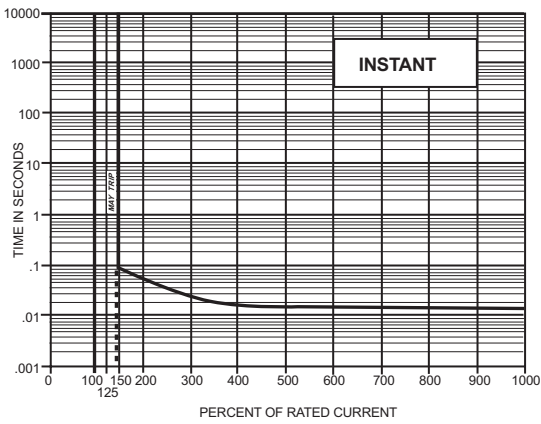
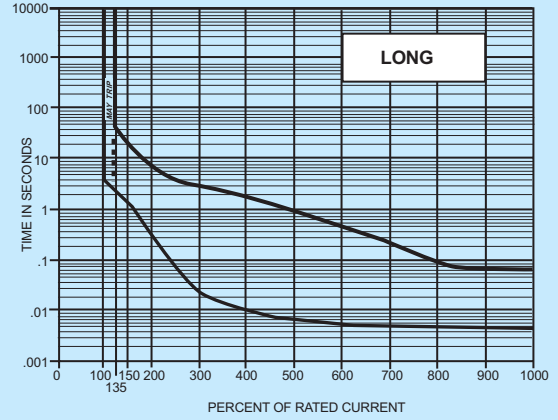



**Trip Free**

AP circuit protectors will trip open on overload, even when forcibly held ON. This prevents the operator from damaging the circuit by holding the handle in the ON position.

**Trip Indication**

The operating handle of the protector moves forcibly and positively to the OFF position on overload. It is not necessary to manually “reset” to full “OFF” in order to turn it on again.

**Ambient Operation**

The protector will operate at any ambient between -40° C and +100° C, when tested in accordance with the requirements of MIL-PRF-39019.

**Insulation Resistance**

Exceeds 100 megohms at a potential of 100Vdc.

**Dielectric Strength**

The protector will withstand 1250 volts RMS, 60Hz from terminals to case and between the terminals when open.

**Endurance**

With the circuit protector operated as an ON-OFF switch, operating life exceeds 10,000 operations at a rate of 6 per minute when tested as follows: 6000 OPS @ rated current plus 4000 OPS @ no load.

**Ratings**

AP protectors are available in current ratings from 50 milliamperes to 20 amperes, 50 volts DC or 240 volts AC maximum, 60 or 400Hz. Please consult factory for ratings other than those noted.

**Short Circuit Capacity**

When tested in accordance with the procedures of UL1077, AP protectors have a short circuit capacity of 1000 amperes at 32Vdc, 120Vac, 240Vac, 60 or 400Hz. Parts are recognized to UL1077 for type UP1 only. The rated Rupture Capacity per MIL-PRF-39019 is 500 amperes, 50 volts DC, 500 amperes, 120 volts AC and 300 amperes, 240 volts AC, 60 or 400Hz.

Auxiliary Switch Rating			
0.5 AMP	@	120Vac	50Vdc

**Case Seal**

The protector is fully sealed and will not show evidence of leakage under total immersion. Meets requirements of MIL-PRF-39019.

**Panel Seal**

The “O” ring provides, with the other illustrated hardware, a seal against a pressure differential of 15 psi applied for an hour.

**Lever Strength**

The operating lever or its seal will not be damaged by a 10 lb. force applied in any direction.

**Shock**

All protectors withstand 100G without tripping, even while carrying full rated current with shock applied in any plane of 6 ms duration. Test is made according to Method 213, Test Condition I or MIL-Std-202 as outlined in Paragraph 4.6.14 of MIL-PRF-39019. Delay 40, 50 and 60 protectors are tested at 80% of rated current.

**Vibration**

All protectors withstand vibration from 10 to 55 cycles at .06 double amplitude and 55 to 2000 cycles at 10G, applied in any plane, without damage and without tripping even while operating at full rated current. Test is made in accordance with Method 204A, Test Condition C, of MIL-Std-202 as outlined in Paragraph 4.6.12 of MIL-PRF-39019. Delay 40, 50 and 60 protectors are tested at 80% of rated current.

Approximate Weight Per Pole	
Ounces	Grams
1.8	49

Recommended Torque Specifications	
6-32 Mounting Inserts	6-8 Inch Pounds
6-32 Screw Terminals	6-8 Inch Pounds
3/8 - 32 Mounting Bushing	20-25 Inch Pounds

## How to Order

The ordering code for AP magnetic circuit protectors may be determined by following the steps in the decision tables shown here.

For example, the following is the code for a two pole AP, hook terminal, series unit, designed for operation in a DC circuit. It has a short time delay and a rating of 20 amperes. The coding given permits a descriptive part number, with limitations. In the illustrated double pole example (AP12-1-51-203), it is automatically assumed that both poles are identical. One great virtue of magnetic circuit protectors is their adaptability to complex circuits, thus variations from pole to pole become the rule rather than the exception. Descriptive drawings are recommended. In this event, factory assigned part numbers are utilized.

To determine the ordering number for your particular AP unit, simply follow the steps shown. You may use this number to place an order or as a reference for further questions you may have.

## Notes:

- A** The UP has a wide glass terminal to meet UL and CSA creepage specifications. Except as completely non-standard there is no space for more than two terminals and the UP is therefore limited to only the single pole series circuit configuration (Third Decision Table – 1). Delays available in the UP are: 40, 50 and 60; 41, 51 and 61; 42, 52 and 62; 64 and 65.
- B** Users should refer to the applicable drawings of MIL-PRF-39019. Configurations vary dependent upon the revision of MIL-PRF-39019. The 6-32 threaded mounted bushings, useful for added strength, are approved under this specification.  
  
To assure that proper parts are received, consult the factory for application assistance if there is any doubt about which version is correct for the application concerned.
- C** Screw terminals are available and are equipped with standard terminal block (see page 58). Space permits their use only in the series configuration (Third Decision Table ). Standard terminals are heavy copper hooks.
- D** Screw terminals with SPDT auxiliary switch, available only with the series circuit, may have "R" soldering terminals, flattened and pierced, or "RC" soldering terminals which are cane hooks. Screw terminals (-7, -17, -117) are available with SPDT auxiliary switch "R" type only.
- E** The nominal current values for 100% of rated current (see delay curves) are those listed. Other values can be readily supplied, in general, without delayed delivery. For values above or below the listed range, please consult an Airpax sales office or sales representative. For UP maximum ratings see page 55.
- F** Consult factory for assigned part numbers.

1 First Decision	
Type	
AP	Fully sealed magnetic circuit protector
UP (Note A)	Underwriters' Laboratories recognized circuit protector
AP - MIL (Note B)	/1 through /6 QPL per MIL-PRF-39019

Example:

AP12 -1 -51-203



2 Second Decision (Note C)		
Poles		
Hook Terminals	Screw Terminals	
1	7	Single pole unit, mounted with 3/8 threaded bushing
12	17	Two pole unit, bushing plus (2) 6-32 threaded inserts
112	117	Three pole unit, bushing plus (2) 6-32 threaded units

3 Third Decision	
Internal Configuration	
-0	Switch Only (Omit 4th and 5th Decisions)
-1	Series
-1R (Note D)	Series with Auxiliary Switch with pierced pin terminals
-1RC (Note D)	Series with Auxiliary Switch with cane hook terminals
-3	Shunt
-4	Relay (5 amps max coil rating)

Multi-pole units with mixed construction, poles numbered left to right when viewed from terminal end (Note F).

4 Fourth Decision	
Hz and Delay	
-40	400Hz 150% instant trip*
-41	400Hz short time delay
-42	400Hz long time delay
-49	400Hz 135% instant trip*
-50	DC 150% instant trip*
-51	DC short time delay
-52	DC long time delay
-59	DC 125% instant trip*
-60	50/60Hz 150% instant trip*
-61	50/60Hz short time delay
-62	50/60Hz long time delay
-64	50/60Hz high pulse, short time delay (50/60Hz only)
-65	50/60Hz high pulse, long time delay (50/60Hz only)
-69	50/60Hz 125% instant trip*
-71	DC, 50/60Hz, 400Hz short time delay 135% trip
-72	DC, 50/60Hz, 400Hz long time delay 135% trip
-79	DC, 50/60Hz, 400Hz instant time delay 135% trip*

For addition of inertial delay, add an "F" to any delay number. Except 40, 50 & 60.

\*Instantaneous delays are not compatible with inrush enhancement options and are not recommended for general use.

5 Fifth Decision (Note E)	
Nominal Amperage Rating	
Code	Amperes
-101	.100
-251	.250
-501	.500
-751	.750
-102	1.000
-252	2.500
-502	5.000
-752	7.500
-103	10.000
-153	15.000
-203	20.000

See page 61 for maximum voltage ratings.

**Note:** Standard current ratings listed. For other ratings, please consult the factory.

