



Hovedkarakteristikk

Produktspekter	Harmony XB4
Produkt eller komponent type	Hode for lystrykknapper
Kallenavn på utstyr	ZB4
Produktkompatibilitet	Innebygget LED
Innfatningsmateriale	Forkrommet metall
Montasjediameter	22 mm
Salg per udelelig kvantitet	1
Formen på varslingsenhetens hode	Rund
Type arm/stempel	Fjærretur
Operatørprofil	Orange innfelt umerket
Knappens tilleggs info.	For innsetting av skilt

Alternativer

Bredde	29 mm
Høyde	29 mm
Dybde	30 mm
Vekt	0.028 kg
Resistens til høytrykksvask	7000000 Pa på 55 °C,avstand: 0.1 m
Mechanical durability	5000000 sykluser
Elektrisk sammensetningskode	C3 for <= 6 kontakter bruker Enkel blokker i frontmontering C4 for <= 6 kontakter bruker enkel og dobbel blokker i frontmontering C14 for <= 2 kontakter bruker Enkel blokker i frontmontering M1 for <= 6 kontakter bruker Enkel blokker i frontmontering med innebygget LED M1 for <= 6 kontakter bruker Enkel blokker i frontmontering med innebygget LED M2 for <= 6 kontakter bruker enkel og dobbel blokker i frontmontering med innebygget LED M10 for <= 2 kontakter bruker Enkel blokker i frontmontering med innebygget LED M6 for <= 2 kontakter bruker Enkel blokker i frontmontering med integrert LED og transformator

Miljø

protective treatment	TH
omgivelsestemperatur for oppbevaring	-40...70 °C
ambefalt temperatur ved drift	-25...70 °C
overspenningskategori	Class I conforming to IEC 60536
IP-grad	IP66 i henhold til IEC 60529
NEMA beskyttelsesgrad	NEMA 13 NEMA 4X
IK beskyttelsesklasse	IK05 i henhold til EN 50102
standarder	EN/IEC 60947-1 EN/IEC 60947-5-1 EN/IEC 60947-5-4 EN/IEC 60947-5-5 JIS C 4520 UL 508 CSA C22.2 No 14
produktsertifikater	BV CSA DNV GL LROS (Lloyds register of shipping) RINA UL listet
Vibrasjonsmotstand	5 gn (f = 2...500 Hz) i henhold til IEC 60068-2-6

&nbps;informasjonen i denne dokumentasjonen inneholder generelle beskrivelser og / eller tekniske egenskaper ved ytelsen til produktene heri. Denne dokumentasjonen er ikke tenkt som en erstatning for, og skal ikke brukes til avgjørelse for egnethet eller pålitelighet av disse produktene til spesifikke brukerapplikasjoner. Det er brukers eller integrators plikt til å foreta den nødvendige og fullstendige risikoanalyse, evaluering og utprøving av produkter med hensyn til den relevante spesifikke anvendelse eller bruk. Hverken Schneider Electric Industries SAS, eller noen av de tilknyttede selskaper eller datterselskaper er ansvarlig for, eller hfter for misbruk av innværende opplysninger.

Dimensions

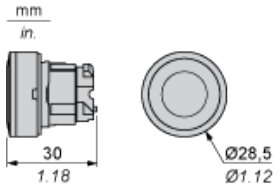

Panel Cut-out for Pushbuttons, Switches and Pilot Lights (Finished Holes, Ready for Installation)

Connection by Screw Clamp Terminals or Plug-in Connectors or on Printed Circuit Board	Connection by Faston Connectors
<p>Diagram showing four circular cut-outs arranged in a 2x2 grid. Dimensions are labeled: (1) diameter, (2) vertical spacing between rows, (3) horizontal spacing between columns, and (4) diameter of the hole.</p>	<p>Diagram showing four circular cut-outs arranged in a 2x2 grid. Dimensions are labeled: (1) diameter, (5) vertical spacing between rows, (6) horizontal spacing between columns, and (4) diameter of the hole.</p>
<p>(1) Diameter on finished panel or support (2) 40 mm min. / 1.57 in. min. (3) 30 mm min. / 1.18 in. min. (4) $\varnothing 22,5$ mm / 0.89 in. recommended ($\varnothing 22,3$ mm $^{+0,4}_0$ / 0.88 in. $^{+0,016}_0$) (5) 45 mm min. / 1.78 in. min. (6) 32 mm min. / 1.26 in. min.</p>	

Pushbuttons, Switches and Pilot Lights for Printed Circuit Board Connection

Panel Cut-outs (Viewed from Installer's Side)

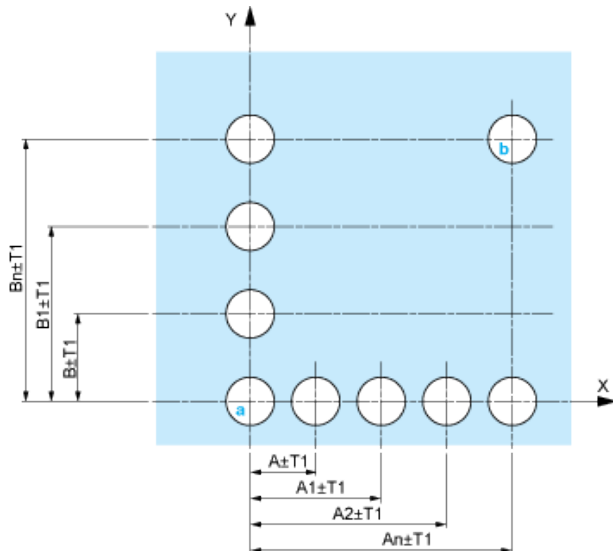

A: 30 mm min. / 1.18 in. min.

B: 40 mm min. / 1.57 in. min.

Printed Circuit Board Cut-outs (Viewed from Electrical Block Side)

Dimensions in mm

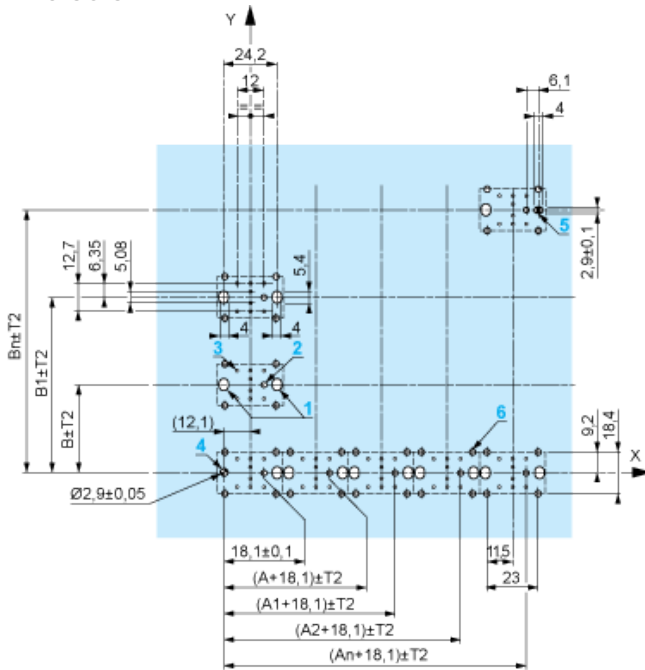

A: 30 mm min.

B: 40 mm min.

Dimensions in in.

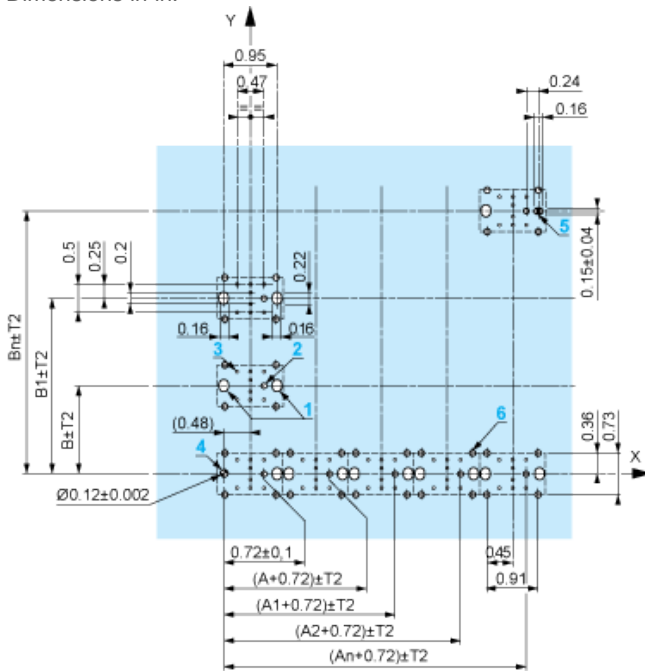

A: 1.18 in. min.

B: 1.57 in. min.

General Tolerances of the Panel and Printed Circuit Board

The cumulative tolerance must not exceed 0.3 mm / 0.012 in: $T1 + T2 = 0.3 \text{ mm max.}$

Installation Precautions

- Minimum thickness of circuit board: 1.6 mm / 0.06 in.
- Cut-out diameter: 22.4 mm \pm 0.1 / 0.88 in. \pm 0.004
- Orientation of body/fixing collar ZB4 BZ009: \pm 2°30' (excluding cut-outs marked **a** and **b**).
- Tightening torque of screws ZBZ 006: 0.6 N.m (5.3 lbf.in) max.
- Allow for one ZB4 BZ079 fixing collar/pillar and its fixing screws:
 - every 90 mm / 3.54 in. horizontally (X), and 120 mm / 4.72 in. vertically (Y).
 - with each selector switch head (ZB4 BD*, ZB4 BJ*, ZB4 BG*).

The fixing centers marked **a** and **b** are diagonally opposed and must align with those marked 4 and 5.

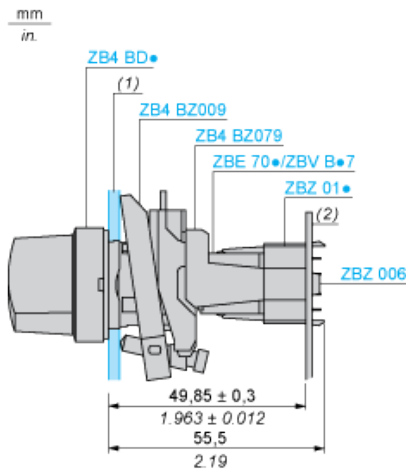

(1) Panel

(2) Printed circuit board

Mounting of Adapter (Socket) ZBZ 01•

- 1 2 elongated holes for ZBZ 006 screw access
- 2 1 hole $\varnothing 2.4 \text{ mm} \pm 0.05 / 0.09 \text{ in.} \pm 0.002$ for centring adapter ZBZ 01•
- 3 8 × $\varnothing 1.2 \text{ mm} / 0.05 \text{ in.}$ holes
- 4 1 hole $\varnothing 2.9 \text{ mm} \pm 0.05 / 0.11 \text{ in.} \pm 0.002$, for aligning the printed circuit board (with cut-out marked **a**)
- 5 1 elongated hole for aligning the printed circuit board (with cut-out marked **b**)
- 6 4 holes $\varnothing 2.4 \text{ mm} / 0.09 \text{ in.}$ for clipping in adapter ZBZ 01•

Dimensions An + 18.1 relate to the $\varnothing 2.4 \text{ mm} \pm 0.05 / 0.09 \text{ in.} \pm 0.002$ holes for centring adapter ZBZ 01•.

Electrical Composition Corresponding to Code C3

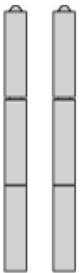

Electrical Composition Corresponding to Code C4

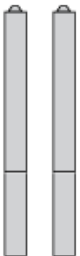

Electrical Composition Corresponding to Codes C14, SF2 and SR2



Electrical Composition Corresponding to Codes M1 and M7

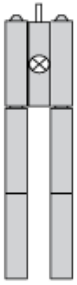

Electrical Composition Corresponding to Codes M2 and M8

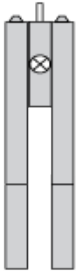

Electrical Composition Corresponding to Codes M6 and P2



Electrical Composition Corresponding to Codes M5, M10, MF1, MR1 and MF2

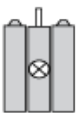

Legend

Single contact



Double contact



Light block



Possible location

