



Arthur Grillo

measuring & controlling systems

Installation and operation manual

DPC200 - DIFFERENTIAL PRESSURE CONTROLLER

Low pressure with PI-control-mode



Manufacturer: Arthur Grillo GmbH
Am Sandbach 7
40878 Ratingen

Phone: 0 21 02 - 47 10 22
Fax: 0 21 02 - 47 58 82
E-mail: info@grillo-messgeraete.de
Website: www.grillo-messgeraete.de
www.sensor-store.de

Issue: 06/2016
Doc.-no.: DPC200_002_UK

This documentation including all parts is protected by copyright. Any utilisation or modification other than permissible under the strict limitations of copyright law is prohibited and liable to prosecution without the approval of the Arthur Grillo GmbH. This applies in particular to duplications, translations, microfilming and storage and processing in electronic systems.

Table of content

1	General safety instructions	04
1.1	Signal words for safety instructions	04
1.2	Used pictograms and symbols	04
1.3	General notes	04
2	Product description	05
2.1	Type plate	05
2.2	Intended use	05
2.3	Functional description	05
3	Installation	06
3.1	Dimensions	06
3.2	Wall mounting	06
4	Start up	07
4.1	Overview DPC200	07
4.2	Schematic view inside	07
4.3	Pressure connections	07
4.4	Electrical connection	08
4.5	Zero adjustment	08
5	Operation	08
5.1	Start menu	08
5.2	Menu structure	09
5.3	Measuring mode	10
5.4	Control mode	11
5.5	Adjustable parameters	12
5.6	Function alarm output	13
6	Maintenance	13
7	Warranty	14
8	Troubleshooting	14
9	Disposal	14
10	Specifications	15
10.1	CE-labelling	16

I. General safety instructions

I.1 Signal words for safety instructions

The safety instructions in this operation manual are designed to prevent hazards. They can be found in the operation manual before an operation / task / activity is described, which can entail a possible hazard.

CAUTION

Identification of a hazard with a low risk, which can lead to material damage or minor or moderate bodily injuries.

NOTICE

Signal word for important information regarding the product, which needs to be specifically pointed out.

Hazard word



Type of hazard

Hazard source

Hazard prevention

I.2 Used pictograms and symbols

In this manual the following symbols are used:



General hazard symbol (danger, warning, caution)



General information

I.3 General notes

NOTICE



This manual contains information for installation and operation of the pressure controller and is exclusively for the operator and expert staff. The guidelines in this manual will help to avoid danger and downtime.



2. Product description

The differential pressure controller DPC200 measures low pressure of inert gases, particularly of air.

2.1 Type plate

1. Product name
2. Measuring range
3. Supply voltage
4. Signal output
5. Serial no.
6. Manufacturer

pressure controller 1.	DPC200- 500
measurement range: 0 ... 500 Pa 2.	
supply voltage: 3. $U_S (1+ 2-) = 10 \dots 30 \text{ Vdc} / 24 \text{ Vac}$	
signal output: 4. $U_{out} (3+ 4-) = 0 \dots 10 \text{ V}$	
part-no.: 2567	5. serial-no.: 15. 4700
Arthur Grillo GmbH • Ratingen 6.	Made in Germany



 IP54

2.2 Intended use

This device is primarily intended for use with air conditioning systems, room pressure control or filter control with ebm-papst continuously variable speed fans. It can be operated solely as a sensor (measuring mode) or closed loop controller for pressure / volumetric flow rate control. As analog output the operator can use a signal from 0 ... 10V DC. Depending on the settings the signal has different meanings:

1. If the device is used as a pressure sensor, the output signal is proportional to the measured pressure.
2. As a volume flow sensor the device outputs a square root signal.
3. With closed loop pressure or volume flow the output signal stands for the control variable of the PI-control.

2.3 Functional description

A soft silicone diaphragm is used as sensor. Under the influence of the differential pressure the diaphragm displaces a measuring spring until the spring force compensates for the pressure pushing on the diaphragm. A contactless differential transformer and suitable electronics convert this displacement into a continuously variable output voltage signal.

The DPC200 provides two function options:

1. On the one hand it is used as a measuring device. In the measuring mode the differential pressure is shown on the display, and a proportional 0... 10V DC output signal is provided.
2. Besides the measuring mode the DPC200 also can be operated in a control mode. Two setpoints can be adjusted in the device and can be selected with the potential free contact input. The PI-Algorithm matches the measured differential pressure with the setpoint and operates the control variable so that a constant pressure results. The control variable is given as a 0... 10V DC output signal.

Instead of the quantity 'differential pressure' also the quantity 'volume flow' can be used for measuring and for control.

3. Installation

The differential pressure controller DPC200 is designed for wall mounting.

- The mounting surface must be solid enough and vibration-free.
- The environment has to fulfill the ambient climatic conditions as given in the technical data.

CAUTION



Material damage

Read the manual carefully before installation and operation
Only experienced staff may connect the device and bring it into operation.

NOTICE



- The device is position depended.
- The DPC200 must be mounted vertically.

3.1 Dimensions

All dimensions in mm.

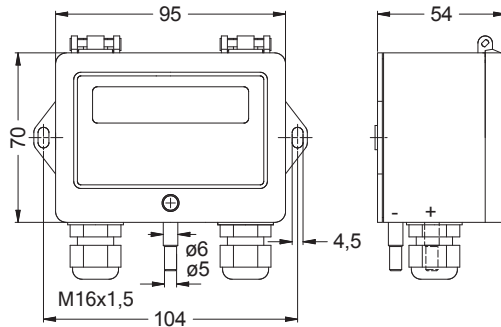

3.2 Wall mounting

1. Hold the DPC200 against the wall. Mark the mounting holes.
2. Drill mounting holes for properly sized screws.
3. Put the screws through the housing mounting holes.
4. Tighten screws.

4. Start up

4.1 Overview DPC200

1. Front cover
2. Cable gland
3. Pressure connection 1
4. Pressure connection 2
5. Cable gland

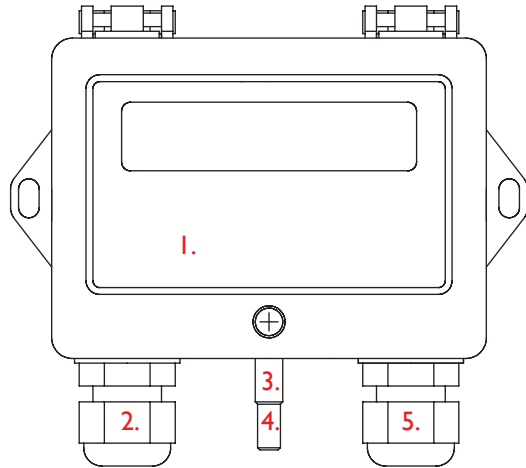

4.2 Schematic view inside

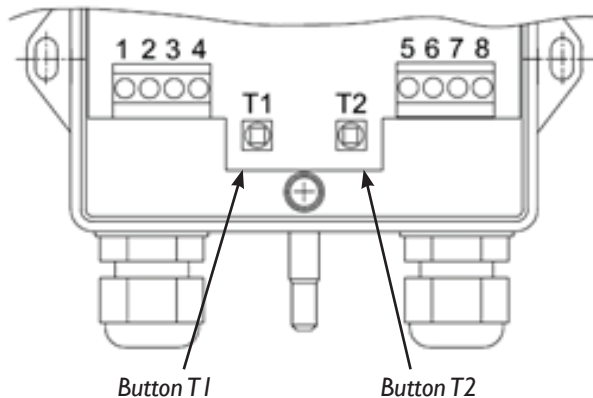

Button T1 and T2 serve for the operation of the menu

4.3 Pressure connections

Connect all pressure connections properly with plastic tubing (inner diameter 5 or 6mm).

4.4 Electrical connection

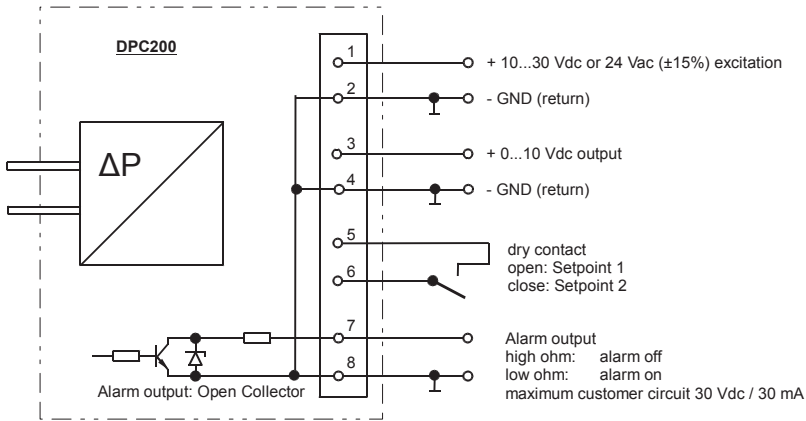

1. Unscrew screws of the front cover.
2. Open front cover.
3. Use M16 cable glands for connecting wiring to terminals.

4.5 Zero adjustment

The output signal offset can be zeroed from the outside with a small bar magnet. Do not use buttons T1 or T2.

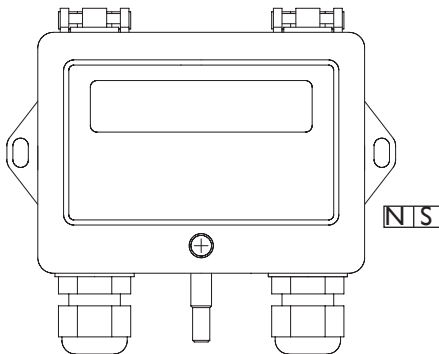

Adjustment:

- Remove the tubing from the pressure connections.
- Hold the bar magnet (N/S) as shown here to the zero point adjustment for a short period of time to activate an internal reed switch.

The new zero point will be displayed and stored.

5. Operation

5.1 Start menu

For operating the menu, unscrew the front cover to reach buttons T1 and T2.

5.2 Menu structure

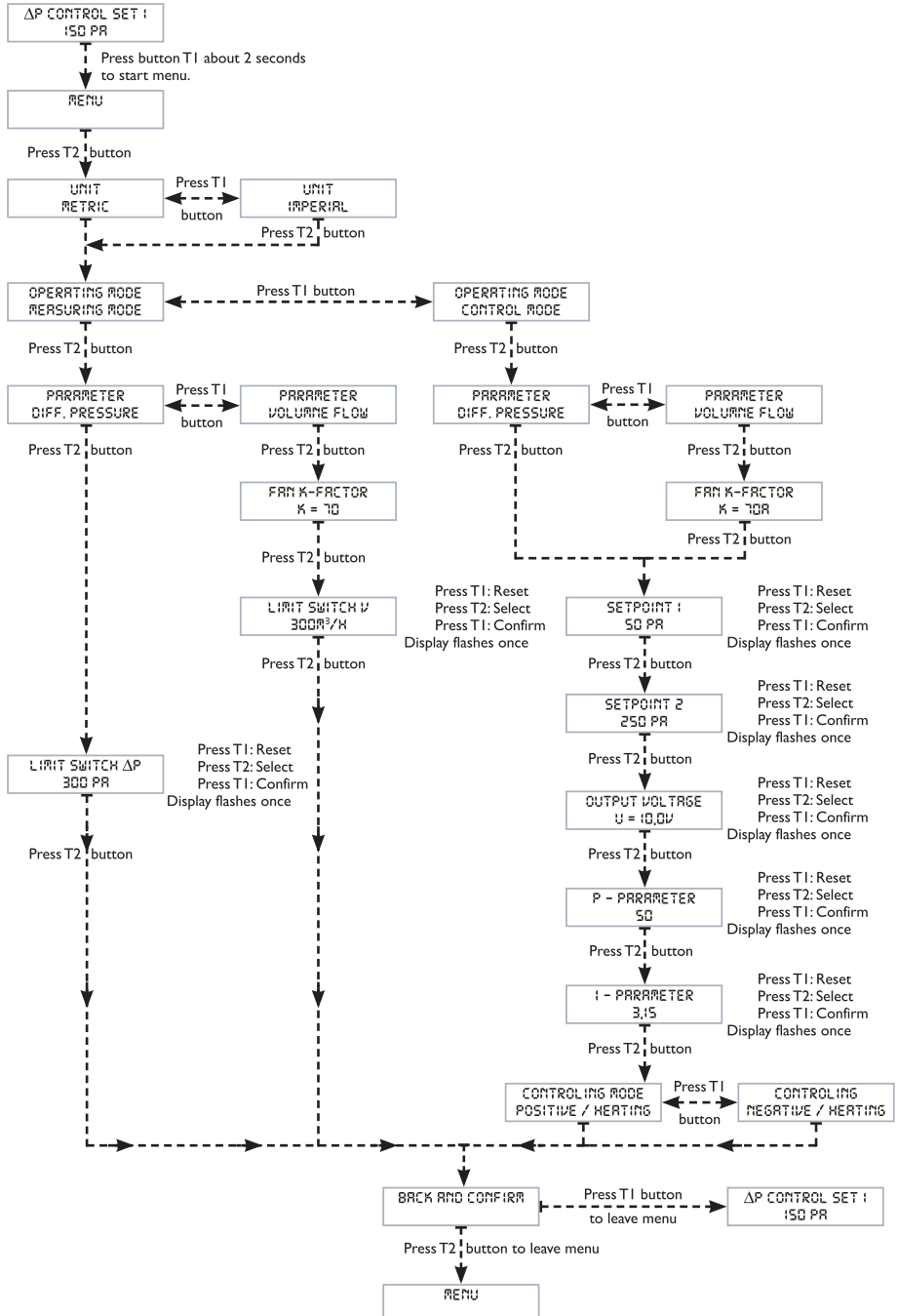

5.3 Measuring mode

Display	Action
ΔP Measurement 200 Pa	Start menu: Press button T1 approx. two seconds
menu	Press button T2 to get to the next menu item
unit metric	Press button T1 to switch between: metric <=> imperial Press button T2 to get to the next menu item
operating mode control mode	Press button T1 to switch between: measuring mode <=> control mode Press button T2 to get to the next menu item
parameter diff. pressure	Press button T1 to switch between: diff. pressure <=> volume flow Press button T2 to get to the next menu item

If selected parameter = diff. pressure	
limit switch 150 Pa	Button T1: reset value Button T2: set value Button T1: confirm value, display flashes once Press button T2 to get to the next menu item
back and confirm	Press button T1 to leave the menu Press button T2 to stay in the menu

If selected parameter = volume flow than follows the additional input for the k-factor	
fan k-factor k = 70	Button T1: reset value Button T2: set value Button T1: confirm value, display flashes once Press button T2 to get to the next menu item
limit switch 300 m³/h	Button T1: reset value Button T2: set value Button T1: confirm value, display flashes once Press button T2 to get to the next menu item
back and confirm	Press button T1 to leave the menu Press button T2 to stay in the menu

5.4 Control mode

Display	Action
ΔP Measurement 200 Pa	Start menu: Press button T1 approx. two seconds
menu	Press button T2 to get to the next menu item
unit metric	Press button T1 to switch between: metric <=> imperial Press button T2 to get to the next menu item
operating mode control mode	Press button T1 to switch between: measuring mode <=> control mode Press button T2 to get to the next menu item
parameter diff. pressure	Press button T1 to switch between: diff. pressure <=> volume flow Press button T2 to get to the next menu item

**If selected parameter = diff. pressure
resp. after the input of the k-factor follows:**

setpoint 1 50 Pa	Button T1: reset value Button T2: set value Button T1: confirm value, display flashes once Press button T2 to get to the next menu item
setpoint 2 250 Pa	Button T1: reset value Button T2: set value Button T1: confirm value, display flashes once Press button T2 to get to the next menu item
output voltage U = 10,0V DC	Button T1: reset value Button T2: set value Button T1: confirm value, display flashes once Press button T2 to get to the next menu item
P - parameter 50	Button T1: reset value Button T2: set value Button T1: confirm value, display flashes once Press button T2 to get to the next menu item
I - parameter 3,15	Button T1: reset value Button T2: set value Button T1: confirm value, display flashes once Press button T2 to get to the next menu item
controlling mode positive / heating	Press button T1 to switch between: positive / heating <=> negative / cooling Press button T2 to go to the next menu
back and confirm	Press button T1 to leave the menu Press button T2 to stay in the menu

**If selected parameter = volume flow
than follows the additional input for the k-factor**

**fan k-factor
k = 70**

Button T1: reset value
 Button T2: set value
 Button T1: confirm value, display flashes once
 Press button T2 to get to the next menu item

5.5 Adjustable parameters

Parameter	Selection or parameter range	Default setting
Unit	Metric or imperial	metric
Operating mode:	Measuring mode or control mode	measuring mode
Parameter	Differential pressure ΔP [Pa or lnH ₂ O] Volume flow V [m ³ /h or cfm]	differential pressure ΔP [Pa]
K-factor:	<p>Volume flow calculation according to: $V = k \cdot \sqrt{\Delta p}$</p> <p>with: V = Volume flow in m³/h or cfm k = flow factor, adjustment range: 1...1000 measuring range up to 4000 Pa Δp = differential pressure in Pa or lnH₂O</p> <p>Volume flow calculation up to 65,500 m³/h (38,514 cfm) In measuring or control mode</p> <p>Maximum volume flow (V_{max}) Measuring range: 50 Pa, k=1000 $\rightarrow V_{max} = 7,071$ m³/h; (4,157 cfm) Measuring range: 500 Pa, k=1000 $\rightarrow V_{max} = 22,360$ m³/h; (13,147 cfm) Measuring range: 1000 Pa, k=1000 $\rightarrow V_{max} = 31,622$ m³/h; (18,593 cfm) Measuring range: 2000 Pa, k=1000 $\rightarrow V_{max} = 44,721$ m³/h; (26,295 cfm) Measuring range: 4000 Pa, k=1000 $\rightarrow V_{max} = 63,245$ m³/h; (37,188 cfm)</p>	K = 70
Limit values:	Differential pressure from 0 % up to 100 % of measuring range. Volume flow from 5 % up to 100 % of measuring range, k-factor is considered.	OFF
Nominal values (setpoints):	Differential pressure from 0 % up to 100 % of measuring range. Volume flow from 5 % up to 100 % of measuring range, k-factor is considered.	Set 1: 75 % Set 2: 25 %
Output voltage:	0...10V DC	$U_{out} = 10V$ DC
P-gain:	0...1000	P = 50
I-gain:	0...100	I = 3.15
Control characteristic:	<p>positive/(heating): Control deviation = set value – actual value The output increases when set value > actual value.</p> <p>negative/(cooling): Control deviation = actual value – set value The output increases when actual value > set value</p>	positive / heating

5.6 Function alarm output

The DPC200 has an open collector alarm output; depending on the operating mode the function is different.

At the **alarm event** a contact between terminal no. 7 and no. 8 gets low-resistive and can be loaded with a maximum of 30 V DC/ 30 mA. When the alarm is switched off the contact will be high-resistive.

During alarm state in the control mode / measuring mode an exclamation point is displayed (2nd line / 16th character).

Control mode:

In order to recognize the limits of control, the alarm output in the control mode refers to the set maximum output voltage (MaxU_{out}). MaxU_{out} can be set in the menu item „output voltage“. In the default setting the value is set to 10V DC.

Alarm ON: Output voltage for 12 seconds constantly greater than: $0.95 \cdot \text{MaxU}_{\text{out}}$

Alarm OFF: Output voltage for 12 seconds constantly less than: $0.9 \cdot \text{MaxU}_{\text{out}}$

Measuring mode:

For limit value monitoring a limit value can be entered. This value is set in the menu item „limit switch“. The previously set parameters are taken into account (unit, parameter, k-factor and the measuring range).

In the default setting the limits are not active. Display 2nd line: „OFF“

Alarm ON: Measurement for 12 seconds constantly greater than $1.0 \cdot \text{limit value}$

Alarm OFF: Measurement for 12 seconds constantly less than $0.95 \cdot \text{limit value}$

6. Maintenance

The DPC200 contains no wearing or consumable parts. Servicing is not required. On request, Arthur Grillo GmbH offers an annual calibration with factory certificate. For information, please contact:



Arthur Grillo GmbH
 Am Sandbach 7
 40878 Ratingen

Phone: +49 21 02 - 47 10 22
 Fax: +49 21 02 - 47 58 82
 E-mail: info@grillo-messgeraete.de

7. Warranty

Warranty and liability claims for personal and property damage are excluded if they are caused by one or more of the following reasons:

- Improper use of the device.
- Improper installation, commissioning, operation and maintenance of the device.
- Unauthorized modifications to the device beyond the intended use.
- Disasters due to external influences and force majeure.

8. Troubleshooting

Description	Activity
Display does not show anything	Check electrical connection
Measurement stays zero	Function test with a slight pressure increase in measuring mode for differential pressure
Measuring error	Perform zeroing as described in chapter 4.5.
Error remains	Contact manufacturer

9. Disposal

Dispose of parts so as not to endanger the human health or environment. Follow the laws in the country of use for disposing of electronic components and devices during disposal.

10. Specifications

Measuring medium:	Air or inert gases	
Measuring principle:	Silicon diaphragm with spring and differential transformer	
Lowest span:	0...50 Pa	
Highest span:	0...6000 Pa	
Overpressure protection:	0.2 bar	
Static pressure:	max. 0.2 bar	
Pressure connections:	tubing 5 mm \varnothing or 6 mm \varnothing	
Enclosure:	UL 94 HB; Case polyamid, cover ABS	
Electrical connections:	cable inlet M16x1.5, screw terminal Electronic protection against reversed polarization	
Supply voltage:	10...30 Vdc; 24 Vac ($\pm 15\%$)	
Current consumption:	approx. 10 mA @ 10 Vdc, approx. 12 mA @ 24 Vdc	
Output:	0...10 V ($I_{\max} = 0.4 \text{ mA @ } 10 \text{ Vdc}$, $I_{\max} = 2 \text{ mA @ } 20 \text{ Vdc}$)	
Alarm output:	Open Collector, max. 30 V / 30 mA	
Display:	LCD-Display, 2 x16 characters	
Mode:	Measuring mode or controlling mode	
Controlling algorithm:	PI	
Setpoints:	2 setpoints adjustable within software, Setpoints are selectable with floating contact input	
Protection class:	IP 54 according EN 60529	
Ambient temperature:	-10...50 °C	
Storage temperature:	-25...60 °C	
Weight:	approx. 250 g	
Mounting:	vertical, position dependence by turning of 90°: approx. 25 Pa	
Interference / emission:	according EN 61000-6-2, EN 61000-6-3, CE mark	
Influences / limits:	Zero error:	$\pm 0.75 \%$
	Sum of linearity and hysteresis (depends on measuring range):	$\pm 0.5 \%$... $\pm 1 \%$
	Temperature drift, zero point:	$\pm 0.3 \%$ / 10 K
	Temperature drift, span:	$\pm 0.2 \%$ / 10 K

10.1 CE-labelling

As an electric device the DPC200 falls within the scope of the directive 2004/108/EG (EMV-directive). In the scope of the EMV-directive the following norms were applied:

DIN EN 61000-6-2:2006-03 correction 1:2011-06	Electromagnetic compatibility (EMC) - Part 6-2: Generic standards - Immunity for industrial environments
DIN EN 61000-6-3:2011-09	Electromagnetic compatibility (EMC) - Part 6-3: Generic standards - Emission standard for residential, commercial and light industrial environments

You can order the Declaration of Conformity at:

