

PCB TERMINAL BLOCKS

5mm Pitch Pluggable for Vertical or 90° mounting Rising Clamp Terminal

- Unique 36 pole strip
- Easily cut to required number of poles
- Can be supplied pre-cut to specified number of poles
- Dual horizontal or vertical mounting
- Moulded in grey UL94-V0 flame retardant PC
- Professional rising clamp terminals
- 0.2-2.5mm² (24-12AWG) solid & stranded cable
- Optional polarising clips
- Anti solder wicking
- Guided pin alignment
- Captive screws
- cULus, CE, approved

SPECIFICATION

Rating	16A/250V UL=14A/300V, VDE&IMQ=16A/250V
Dielectric strength	≥2.5kV
Impulse withstand voltage	4kV
Working temperature	130°C
Moulding	UL94-V0 flame retardant PC
Pin/terminal	Tinned, nickel plated brass
Rising clamp	Zinc plated steel
Screw/torque	M2.5 steel zinc plated, 0.4Nm
Recommended PCB hole size	ø1.3mm

Female connector

TYPE NO.	POLES	LENGTH
CTB7300/2F	2	10mm
CTB7300/3F	3	15mm
CTB7300/4F	4	20mm
CTB7300/5F	5	25mm
CTB7300/6F	6	30mm
CTB7300/7F	7	35mm
CTB7300/8F	8	40mm
CTB7300/9F	9	45mm
CTB7300/10F	10	50mm
CTB7300/11F	11	55mm
CTB7300/12F	12	60mm
CTB7300/36F	36	180mm

CTB7300/F

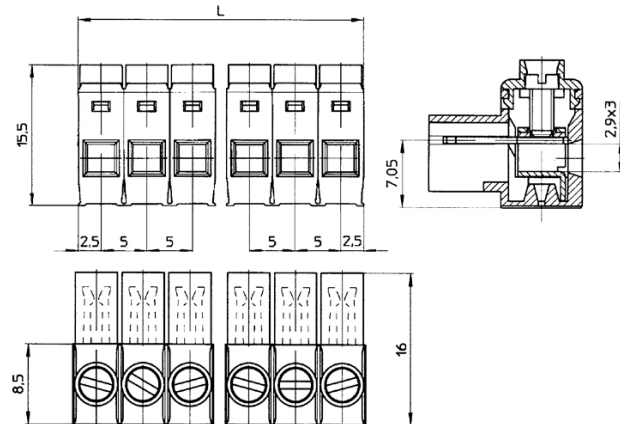

PCB mounting male

TYPE NO.	POLES	LENGTH
CTB7300/2M	2	10mm
CTB7300/3M	3	15mm
CTB7300/4M	4	20mm
CTB7300/5M	5	25mm
CTB7300/6M	6	30mm
CTB7300/7M	7	35mm
CTB7300/8M	8	40mm
CTB7300/9M	9	45mm
CTB7300/10M	10	50mm
CTB7300/11M	11	55mm
CTB7300/12M	12	60mm
CTB7300/36M	36	180mm

CTB7300/M

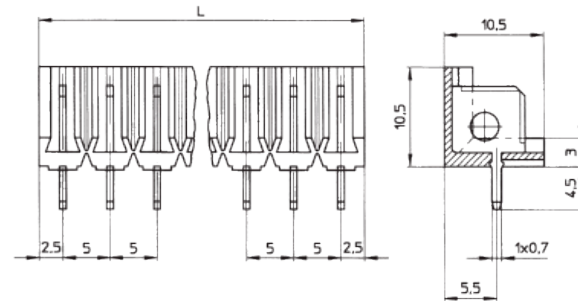

Polarising Clip

TYPE NO.	
CTB7300C	1 pair

Fitted to each end of the male connector ensures correct vertical or horizontal orientation of the female part

CTB7300/C

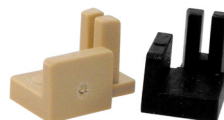

PCB TERMINAL BLOCKS

INTER-CONNECTION

FUSES & FUSE-HOLDERS

LEDs & INDICATORS

MINIATURE SWITCHES

LIMIT & SAFETY SWITCHES

CONTROL PRODUCTS

INTERFACE MODULES & SUPPORTS

RELAY BASES

ENCLOSURES

BATTERIES

TRANSFORMERS