

Features

- Wide 4:1 Input Voltage Range
- 1.6kVDC Isolation for 24Vin and 48Vin, 3kVDC Isolation for 110Vin
- Efficiency up to 92%
- Six-Sided Continuous Shield
- UL60950-1 AM2 Certified, EN50155 Certified

Regulated Converters



RP40-FR

40 Watt
2" x 1"
Single & Dual Output



Description

The RP40-FR series wide range input DC/DC converters have been especially designed for railway applications and are EN50155 certified. They are also pending to UL60950-1 and cUL 60950-1, this makes them ideal for all high input voltage telecom and industrial applications where approved safety standards are required.

Selection Guide

Part Number	Input Voltage Range [VDC]	Output Voltage [VDC]	Output Current [mA]	Input (1) Current [mA]	Efficiency (1) typ. [%]	Max. Capacitive Load (2) [μF]
RP40-243.3SFR ^(3,4)	9-36	3.3	10000	1528	90	26600
RP40-2405SFR ^(3,4)	9-36	5	8000	1832	91	20000
RP40-2412SFR ^(3,4)	9-36	12	3333	1811	92	3900
RP40-2415SFR ^(3,4)	9-36	15	2666	1811	92	2600
RP40-2424SFR ^(3,4)	9-36	24	1666	1831	91	1300
RP40-483.3SFR ^(3,4)	18-75	3.3	10000	764	90	26600
RP40-4805SFR ^(3,4)	18-75	5	8000	916	91	20000
RP40-4812SFR ^(3,4)	18-75	12	3333	906	92	3900
RP40-4815SFR ^(3,4)	18-75	15	2666	906	92	2600
RP40-4824SFR ^(3,4)	18-75	24	1666	915	91	1300
RP40-1103.3SFR ^(3,4)	43-160	3.3	10000	341	88	26600
RP40-11005SFR ^(3,4)	43-160	5	8000	409	89	20000
RP40-11012SFR ^(3,4)	43-160	12	3333	402	90.5	3900
RP40-11015SFR ^(3,4)	43-160	15	2666	400	91	2600
RP40-11024SFR ^(3,4)	43-160	24	1666	404	90	1300
RP40-2412DFR ^(3,4)	9-36	±12	±1666	926	90	±2600
RP40-2415DFR ^(3,4)	9-36	±15	±1333	926	90	±1600
RP40-2424DFR ^(3,4)	9-36	±24	±833	915	91	±650
RP40-4812DFR ^(3,4)	18-75	±12	±1666	463	90	±2600
RP40-4815DFR ^(3,4)	18-75	±15	±1333	370	90	±1600
RP40-4824DFR ^(3,4)	18-75	±24	±833	286	91	±650
RP40-11012DFR ^(3,4)	43-160	±12	±1666	204	89	±2600
RP40-11015DFR ^(3,4)	43-160	±15	±1333	204	89	±1600
RP40-11024DFR ^(3,4)	43-160	±24	±833	200	91	±650

Notes:

Note1: Values at nominal input voltage and full load

Note2: Test by minimum Vin and constant resistor load.



EN50155 Certified
UL60950-1 AM2 Certified

Model Numbering

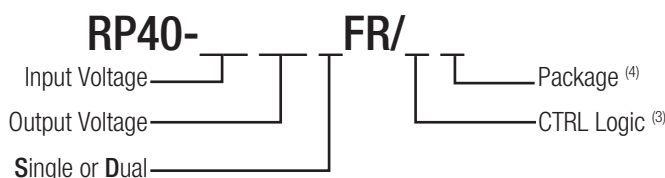

Ordering Examples

RP40-2405SFR/P = 24V Input, 5V Output, Positive Logic CTRL pin and Trim pin fitted

RP40-2415SFR/N = 24V Input, 15V Output, Negative Logic CTRL pin and Trim pin fitted

Notes:

Note3: standard part is with suffix "P" for positive logic (1=ON, 0=OFF) and trim pin or add suffix "N" instead for negative logic (0=ON, 1=OFF) and trim pin

Note4: add suffix "-HC" for premounted Heat-sink with clamps

Specifications (measured @ $t_a = 25^\circ\text{C}$, nominal input voltage, full load otherwise noted)

BASIC CHARACTERISTICS					
Parameter	Condition		Min.	Typ.	Max.
Input Voltage Range	nom. $V_{in} = 24\text{V}$ nom. $V_{in} = 48\text{V}$ nom. $V_{in} = 110\text{V}$		9VDC 18VDC 43VDC	24VDC 48VDC 110VDC	36VDC 75VDC 160VDC
Under Voltage Lockout (UVLO)	$V_{in} = 24\text{V}$	DC-DC ON DC-DC OFF		8VDC	9VDC
	$V_{in} = 48\text{V}$	DC-DC ON DC-DC OFF		16VDC	18VDC
	$V_{in} = 110\text{V}$	DC-DC ON DC-DC OFF		40VDC	43VDC
Input Filter			Pi-Type		
Input Reflected Ripple Current	nominal V_{in} and full load			30mA _{p-p}	
Input Surge Voltage	$V_{in} = 24\text{V}$, 1s max. $V_{in} = 48\text{V}$, 1s max. $V_{in} = 110\text{V}$, 1s max.				50VDC 100VDC 170VDC
Start-up time	Power up Remote ON/OFF			60ms 60ms	
Internal Operating Frequency			225kHz	250kHz	275kHz
Ripple and Noise	measured by 20Mhz bandwidth with a $1\mu\text{F}/50\text{V}$ X7R MLCC	3.3V _{out} , 5V _{out} 12V _{out} , 15V _{out} 24V _{out}		75mV _{p-p} 100mV _{p-p} 150mV _{p-p}	100mV _{p-p} 125mV _{p-p} 200mV _{p-p}
ON/OFF CTRL ⁽⁵⁾		Positive Logic	DC-DC ON DC-DC OFF	Open or $3.0\text{V} < V_r < 12\text{V}$ Short or $0\text{V} < V_r < 1.2\text{V}$	
	Negative Logic	DC-DC ON DC-DC OFF	Short or $0\text{V} < V_r < 1.2\text{V}$ Open or $3.0\text{V} < V_r < 12\text{V}$		
Input current of Remote pin (CTRL)	DC-DC OFF			3mA	
	DC-DC ON		-0.5mA		0.5mA

Notes:

Note5: The pin voltage is referenced to - V_{in} pin.

RP40-2405SFR

Efficiency vs. Output Current

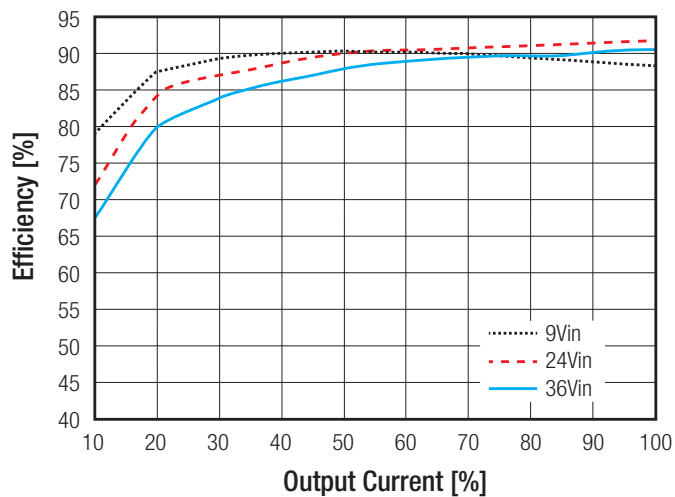

Efficiency vs. Input Voltage full load

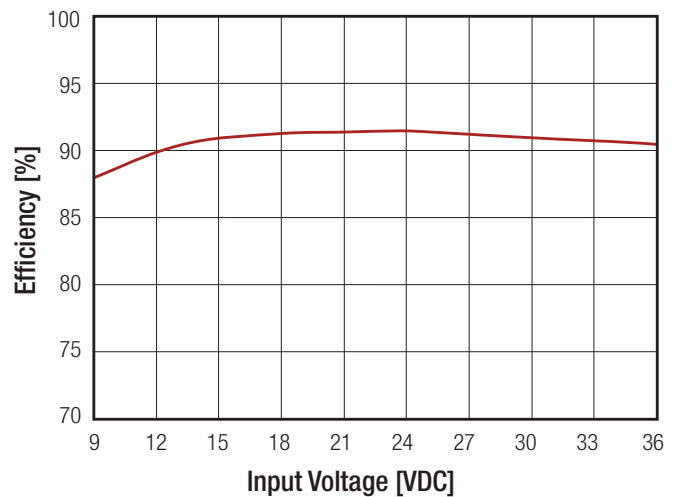

continued on next page

Specifications (measured @ $t_a = 25^\circ\text{C}$, nominal input voltage, full load otherwise noted)

RP40-4805SFR

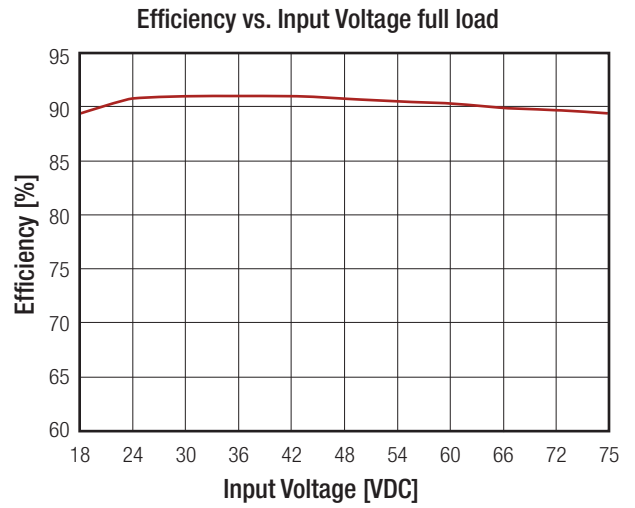
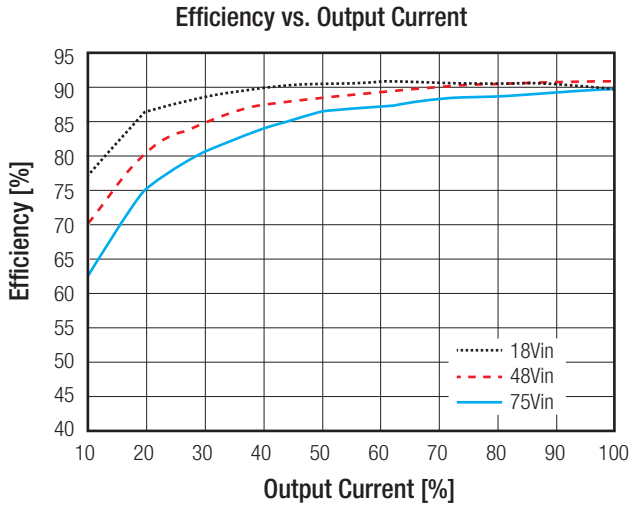

RP40-1105SFR

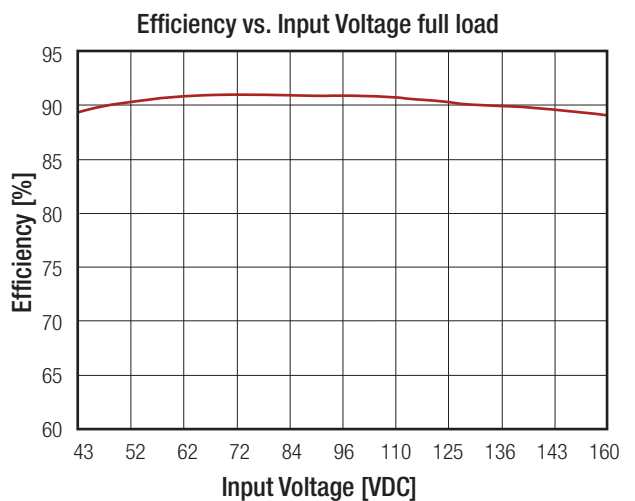
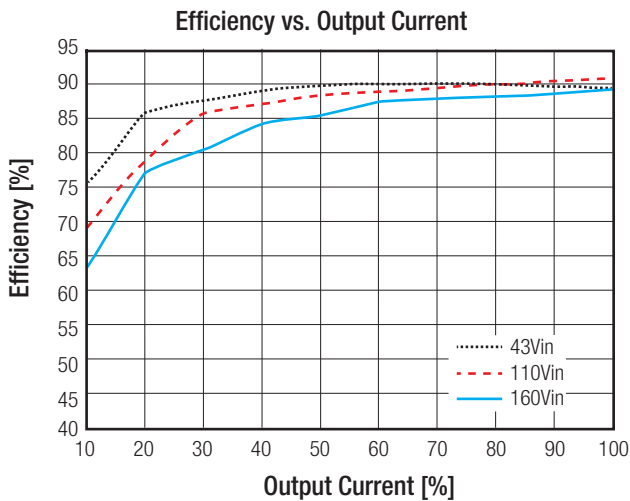

REGULATIONS

Parameter	Condition	Value
Output Voltage Accuracy	full load and nominal V_{in}	$\pm 1\%$
Voltage Adjustability	Single 3.3Vout, 5 Vout, 12Vout 15Vout, 24Vout	$\pm 10\%$ -10% to +20%
Line Voltage Regulation	low line to high line at full load	$\pm 0.2\%$
Load Voltage Regulation	0% to 100% load Single Dual	$\pm 0.5\%$ $\pm 1.0\%$
Cross Regulation	asymmetrical 25% <> 100% load	$\pm 5\%$
Transient Response recovery time	25% load step change	250 μs typ.

continued on next page

Specifications (measured @ $t_a = 25^\circ\text{C}$, nominal input voltage, full load otherwise noted)

External Output Trimming

Output Voltage Trimming

Single output Powerline converters offer the feature of trimming the output voltage over a certain range around the nominal value by using external trim resistors. No general equation can be given for calculating the trim resistors, but the following trimtables give typical values for choosing these trimming resistors. If voltages between the given trim points are required, extrapolate between the two nearest given values to work out the resistor required or use a variable resistor to set the output voltage. Output can be externally trimmed by using the method shown below.

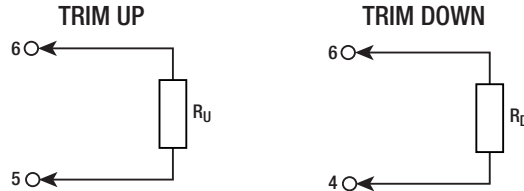

RP40-xx3.3SFR

Trim up	1	2	3	4	5	6	7	8	9	10	%
V _{out} =	3.333	3.366	3.399	3.432	3.465	3.498	3.531	3.564	3.597	3.63	Volts
R _U =	57.93	26.17	15.57	10.28	7.11	4.98	3.48	2.34	1.46	0.75	KOhms
Trim down	1	2	3	4	5	6	7	8	9	10	%
V _{out} =	3.267	3.234	3.201	3.168	3.135	3.102	3.069	3.036	3.003	2.97	Volts
R _D =	69.47	31.24	18.49	12.12	8.29	5.75	3.92	2.56	1.50	0.65	KOhms

RP40-xx05SFR

Trim up	1	2	3	4	5	6	7	8	9	10	%
V _{out} =	5.05	5.10	5.15	5.20	5.25	5.30	5.35	5.4	5.45	5.50	Volts
R _U =	36.57	16.58	9.92	6.89	4.59	3.25	2.30	1.59	1.03	0.59	KOhms
Trim down	1	2	3	4	5	6	7	8	9	10	%
V _{out} =	4.95	4.90	4.85	4.80	4.75	4.70	4.65	4.60	4.55	4.50	Volts
R _D =	45.533	20.612	12.306	8.152	5.66	3.999	2.812	1.922	1.23	0.676	KOhms

RP40-xx12SFR

Trim up	1	2	3	4	5	6	7	8	9	10	%
V _{out} =	12.12	12.24	12.36	12.48	12.60	12.72	12.84	12.96	13.08	13.20	Volts
R _U =	367.91	165.95	98.636	64.977	44.782	31.318	21.701	14.488	8.879	4.391	KOhms
Trim down	1	2	3	4	5	6	7	8	9	10	%
V _{out} =	11.88	11.76	11.64	11.52	11.40	11.28	11.16	11.04	10.92	10.8	Volts
R _D =	460.99	207.95	123.6	81.423	56.118	39.249	27.199	18.162	11.132	5.509	KOhms

continued on next page

Specifications (measured @ $t_a = 25^\circ\text{C}$, nominal input voltage, full load otherwise noted)

RP40-xx15SFR											
Trim up	1	2	3	4	5	6	7	8	9	10	%
V _{out} =	15.15	15.3	15.45	15.60	15.75	15.90	16.05	16.20	16.35	16.50	Volts
R _γ =	419.81	199.91	126.60	89.95	67.96	53.30	42.83	34.98	28.87	23.98	KOhms
Trim up	11	12	13	14	15	16	17	18	19	20	%
V _{out} =	16.650	16.800	16.950	17.100	17.250	17.400	17.550	17.700	17.850	18.000	Volts
R _γ =	19.98	16.65	13.83	11.42	9.32	7.49	5.87	4.43	3.15	1.99	KOhms
Trim down	1	2	3	4	5	6	7	8	9	10	%
V _{out} =	14.850	14.700	14.550	14.400	14.250	14.000	13.750	13.500	13.250	13.000	Volts
R _β =	284.89	128.68	76.61	50.58	34.96	24.55	17.11	11.53	7.19	3.72	KOhms
RP40-xx24SFR											
Trim up	1	2	3	4	5	6	7	8	9	10	%
V _{out} =	24.240	24.480	24.720	24.960	25.200	25.440	25.680	25.920	26.160	26.400	Volts
R _γ =	1275.2	606.60	383.73	272.30	205.44	160.87	129.03	105.15	86.58	71.72	KOhms
Trim up	11	12	13	14	15	16	17	18	19	20	%
V _{out} =	26.640	26.880	27.120	27.360	27.600	27.840	28.080	28.320	28.560	28.800	Volts
R _γ =	59.56	49.43	40.86	33.51	27.15	21.57	16.66	12.29	8.38	4.86	KOhms
Trim down	1	2	3	4	5	6	7	8	9	10	%
V _{out} =	23.760	23.520	23.280	23.040	22.800	22.560	22.320	22.080	21.840	21.600	Volts
R _β =	838.15	376.78	222.98	146.09	99.95	69.19	47.22	30.74	17.93	7.68	KOhms

PROTECTIONS			
Parameter	Condition	Value	
Short Circuit Protection (SCP)		continuous, automatic recovery	
Over Voltage Protection (OVP)	Zener Diode Clamp	3.3V _{out}	3.9VDC
		5V _{out}	6.2VDC
		12V _{out}	15VDC
		15V _{out}	20VDC
		24V _{out}	30VDC
Over Load Protection (OLP)	% I _{out} rated	150% typ., Hiccup Mode	
Over Temperature Protection (OTP)		115°C	
Isolation Voltage	24V _{in} , 48V _{in}	I/P to O/P	1.6kVDC
		I/P to O/P to Case	1.6kVDC
Isolation Voltage	110V _{in}	I/P to O/P	3kVDC
		I/P to O/P to Case	1.6kVDC
Isolation Resistance	500VDC	1GΩ min.	
Isolation Capacitance		1500pF max.	
Notes: Note6: This power module is not internally fused. An input line fuse must always be used.			

Specifications (measured @ $t_a = 25^\circ\text{C}$, nominal input voltage, full load otherwise noted)

ENVIRONMENTAL		
Parameter	Condition	Value
Operating Temperature Range	without derating, without Heat-Sink	-40°C to +60°C
	with derating	-40°C to +105°C
Maximum Case Temperature		+105°C
Temperature Coefficient		$\pm 0.02\%/^\circ\text{C}$ max.
Thermal Impedance	Natural convection, without Heat-sink	10.8°C/W
	Natural convection, with Heat-sink	10.3°C/W
Operating Humidity		5% - 95% RH
Shock		EN61373, MIL-STD-810F
Thermal Shock		MIL-STD-810F
Vibration		EN61373, MIL-STD-810F
MTBF	MIL-HDBK-217F	907.3 x 10 ³ hours

Derating Graph ⁽⁷⁾

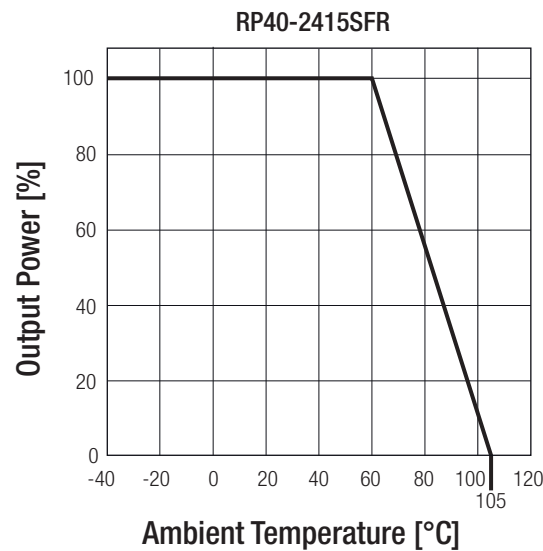

Notes:

Note7: Derating graphs are valid only for the shown part numbers. If you need detailed derating-information about a part-number not shown here please contact our technical support service at techsupportAT@recom-power.com

SAFETY AND CERTIFICATIONS		
Certificate Type (Safety)	Report / File Number	Standard
Information Technology Equipment, General Requirements for Safety	E196683	UL60950-1, 2nd Edition AM:2, 2014 CSA C22.2 No. 60950-1-07
Railway Applications - Electrical Equipment used on rolling stock	15A100702E-C	EN50155, 2007
EMI Compliance	Condition	Standard / Criterion
Industrial, scientific and medical equipment - Radio frequency disturbance characteristics - Limits and methods of measurement ⁽⁸⁾	with external filter	EN50121-3-2, Class A EN55011, Class A or B
ESD Electrostatic discharge immunity test	Air $\pm 8\text{kV}$ and Contact $\pm 6\text{kV}$	EN61000-4-2, Criteria A
Radiated, radio-frequency, electromagnetic field immunity test	20 V/m	EN61000-4-3, Criteria A
Fast Transient and Burst Immunity ⁽⁹⁾	$\pm 2\text{kV}$	EN61000-4-4, Criteria A
Surge Immunity ⁽⁹⁾	$\pm 2\text{kV}$	EN61000-4-5, Criteria A
Immunity to conducted disturbances, induced by radio-frequency fields	10 Vr.m.s	EN61000-4-6, Criteria A
Power Magnetic Field Immunity	100A/m continuous; 1000A/m 1s	EN61000-4-8, Criteria A

continued on next page

Specifications (measured @ $t_a = 25^\circ\text{C}$, nominal input voltage, full load otherwise noted)

Notes:

Note8: The standard module meets EMI Class A or Class B with external components.

Note9: An external input filter capacitor is required if the module has to meet EN61000-4-4 and -4-5.

The R40-24xxFR requires an aluminum electrolytic capacitor (Nippon chemi-con KY series, 220 μF /100V) and a TVS (SMDJ58A, 58V, 3000Watt peak pulse power) connected in parallel.

The RP40-48xxFR requires an aluminum electrolytic capacitor (Nippon chemi-con KY series, 220 μF /100V) and a TVS (SMDJ120A, 120V, 3000Watt peak pulse power) connected in parallel.

The RP40-110xxFR requires an aluminum electrolytic capacitor (Ruby-con BXF series, 68 μF /200V 3pcs in parallel) and a TVS (SMDJ90A, 90V, 3000Watt peak pulse power 2pcs in series connection) connected in parallel.

EMC Filtering Class A - Railway Application with Single Output

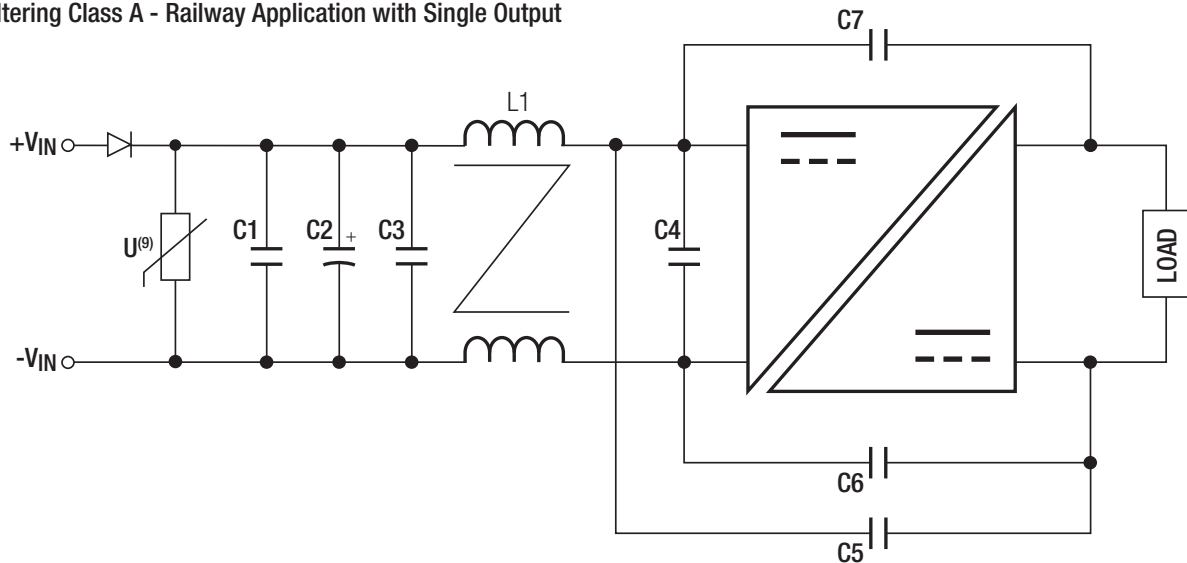

EMC Filtering Class A - Railway Application with Dual Output

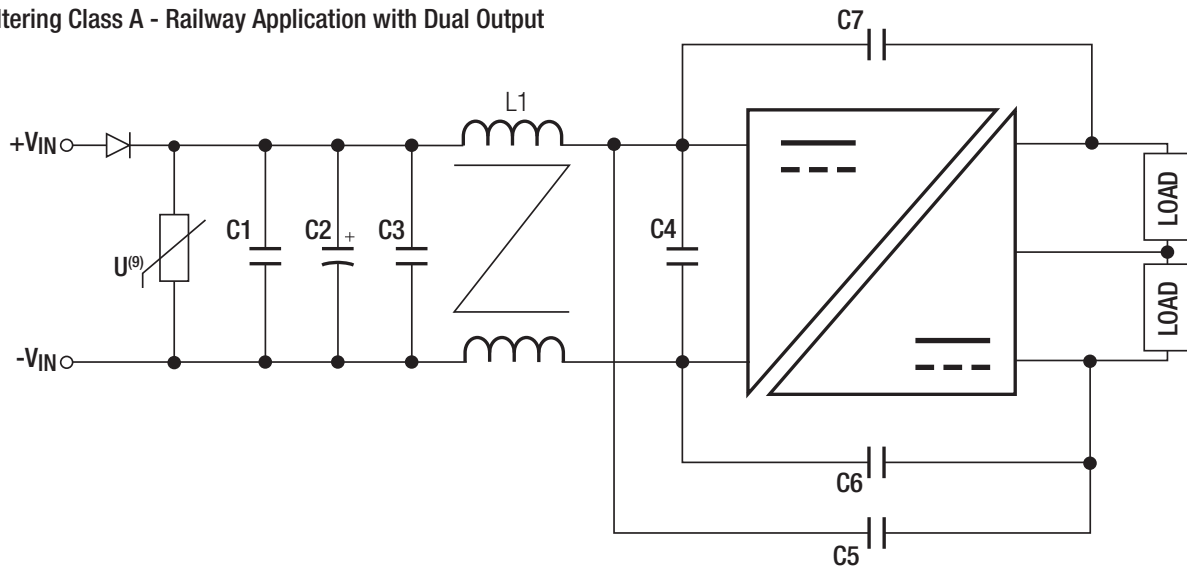

MODEL	C1	C2	C3	C4	C5	C6	C7	L1
RP40-24xxS_DFR	220 μF /200V MLCC	N/A	N/A	10 μF /50V 1210 MLCC	680pF/3kV 1808 MLCC			2.2 μH 11A SMD Inductor
RP40-48xxS_DFR				4.7 μF /100V 1210 MLCC				12 μH 4A SMD Inductor
RP40-110xxS_DFR		33 μF /250V Al Cap. (lie down) Chemi-con KXJ	1 μF /250V 1812 MLCC	1 μF /250V 1812 MLCC		1000pF TDK CD series Y1		22 μH 1.5A SMD Inductor

continued on next page

Specifications (measured @ $t_a = 25^\circ\text{C}$, nominal input voltage, full load otherwise noted)

EMC Filtering Class A - Industrial Applications with Single Output

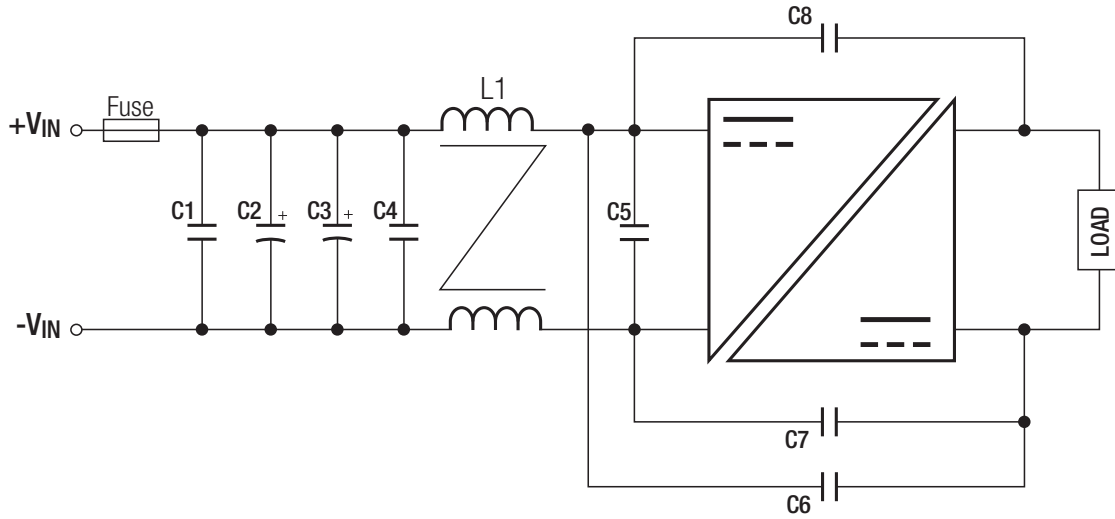

EMC Filtering Class A - Industrial Applications with Dual Output

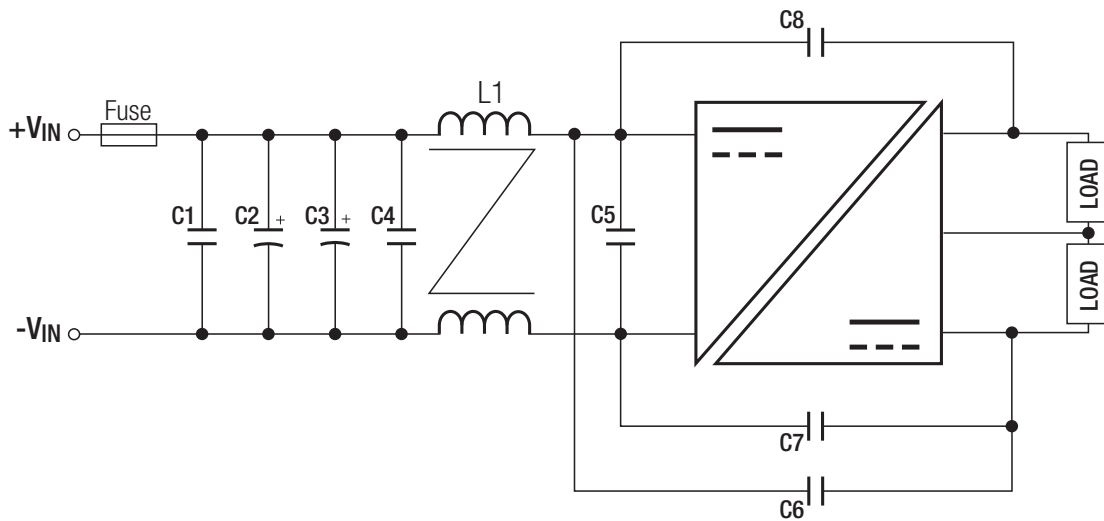

MODEL	C1	C2	C3	C4	C5	C6	C7	C8	L1
RP40-24xxS_DFR	10 μF /50V 1210 MLCC	N/A	N/A	N/A	10 μF /50V 1210 MLCC	680pF/3kV 1808 MLCC			2.2 μH 11A SMD Inductor
RP40-48xxS_DFR	4.7 μF /100V 1210 MLCC				4.7 μF /100V 1210 MLCC				12 μH 4A SMD Inductor
RP40-110xxS_DFR	N/A	33 μF /250V Al Cap. (lie down) Chemi-con KXJ		1 μF /250V 1812 MLCC	1000pF TDK CD series Y1			22 μH 1.5A SMD Inductor	

continued on next page

Specifications (measured @ $t_a = 25^\circ\text{C}$, nominal input voltage, full load otherwise noted)

EMC Filtering Class B with Single Output

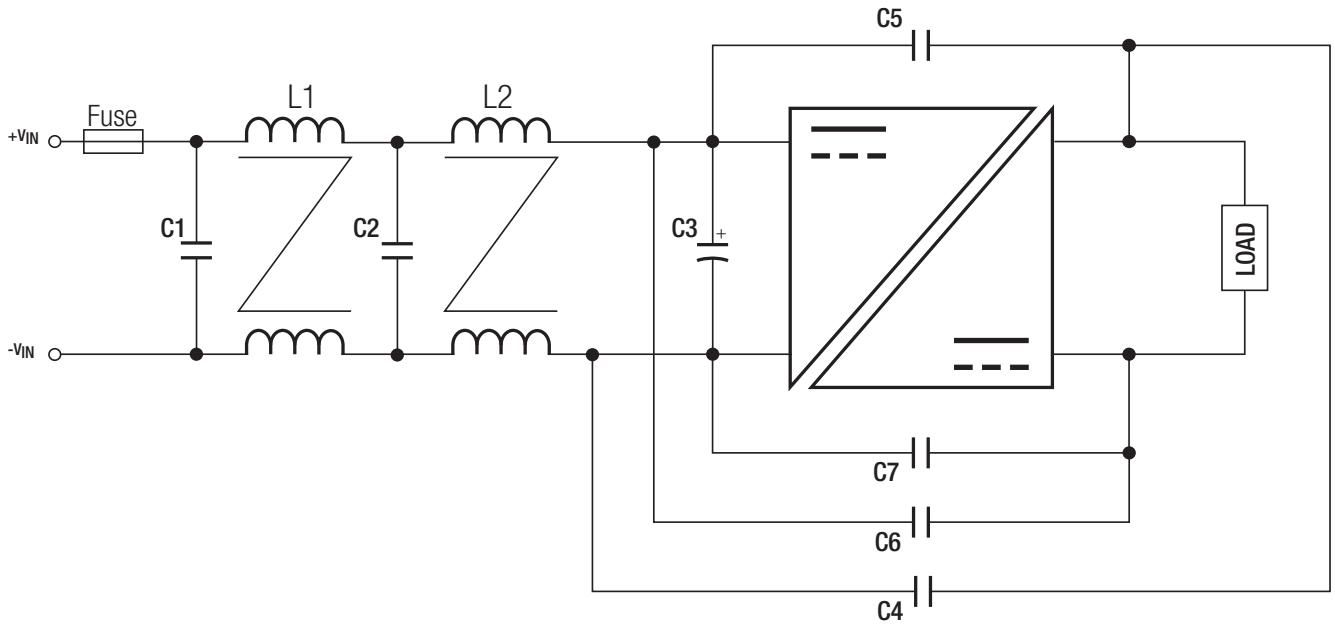

EMC Filtering Class B with Dual output

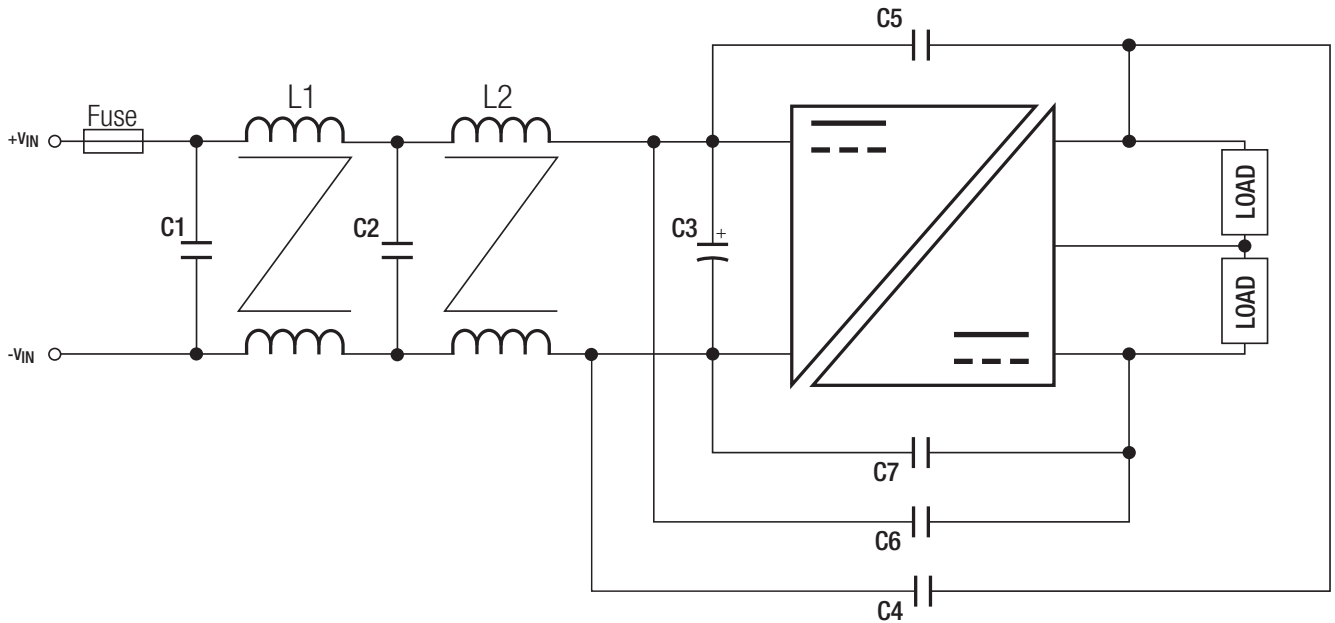

MODEL	C1/C2	C3	C4/C6	C5/C7	L1/L2
RP40-24xxS_DFR	10 μF /50V 1210 MLCC	82 μF /100V Al Cap. (lie down)	1000pf/3kV 1808 MLCC	2200pf/3kV 1808 MLCC	3.3 μH 10A SMD Inductor
RP40-48xxS_DFR	4.7 μF /100V 1210 MLCC	Chemi-con KJ			12 μH 4A SMD Inductor

continued on next page

Specifications (measured @ $t_a = 25^\circ\text{C}$, nominal input voltage, full load otherwise noted)

EMC Filtering Class B for Single Output

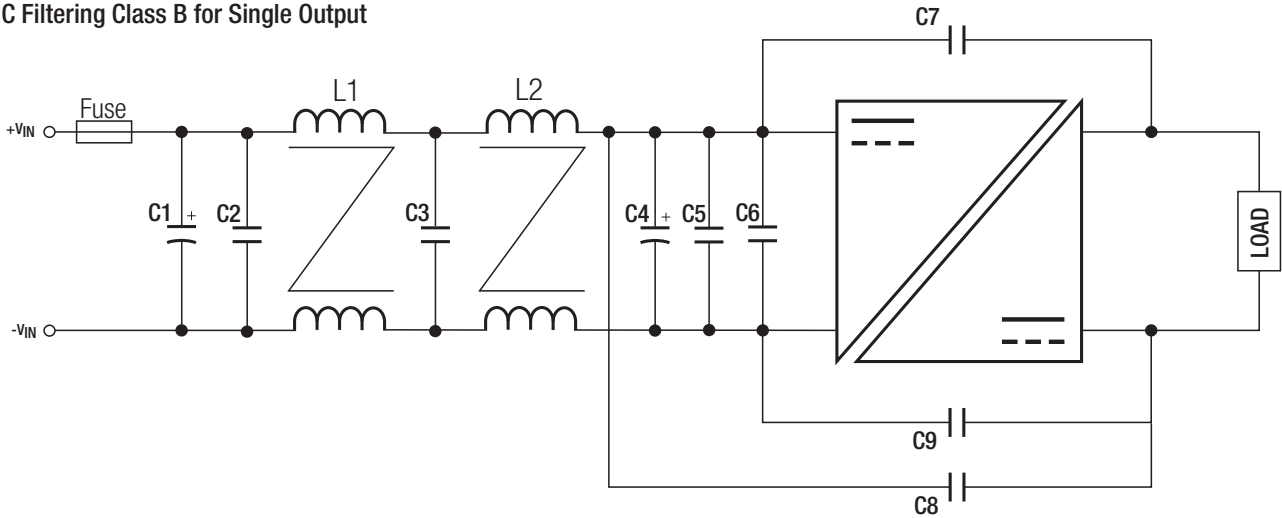

EMC Filtering Class B for Dual output

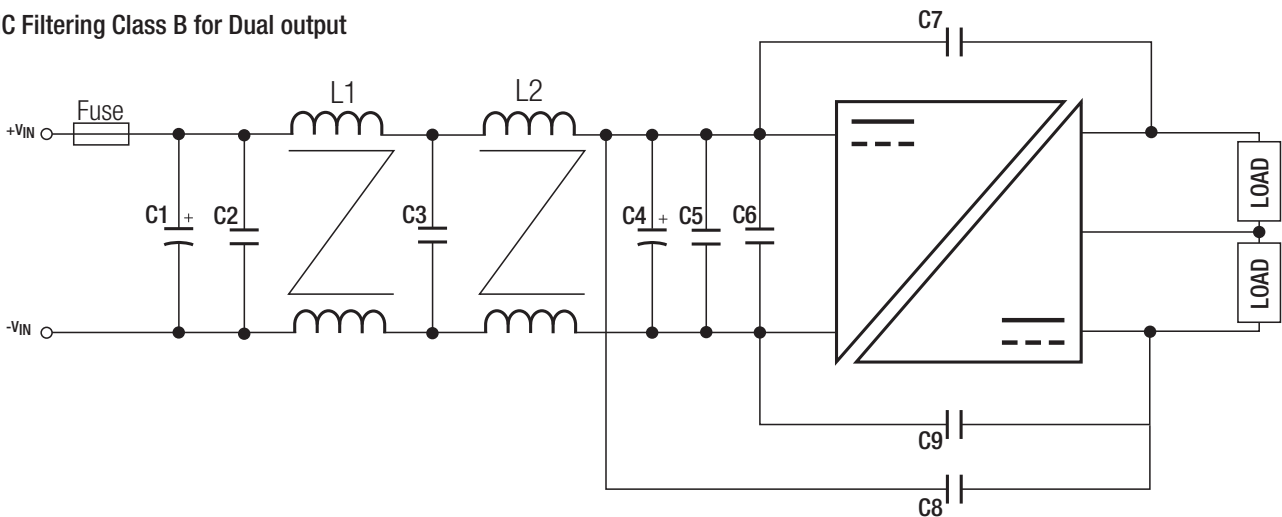

MODEL	C1	C2/C3	C4	C5/C6	C7/C8/C9	L1/L2
RP40-110xxS_DFR	33 μF /250V Al Cap. (lie down) Chemicon -KXJ	1 μF /250V 1812 MLCC	33 μF /250V Al Cap. (lie down) Chemicon -KXJ	1 μF /250V 1812 MLCC	2200pF TDK CD series Y1	22 μH 1.5A SMD Inductor

DIMENSIONS and PHYSICAL CHARACTERISTICS

Parameter	Type	Value
Material	Case	Copper Alloy CuZn33
	Base	FR4 PCB
	Potting	Silicone (UL94V-0)
Packaging Dimension (LxWxH)	without Heat-sink	50.8 x 25.4 x 10.2mm
	with Heat-sink	56.8 x 25.4 x 16.8mm
Packaging Weight	without Heat-sink	32g
	with Heat-sink	43g

continued on next page

Specifications (measured @ ta = 25°C, nominal input voltage, full load otherwise noted)

Dimension Drawing (mm)

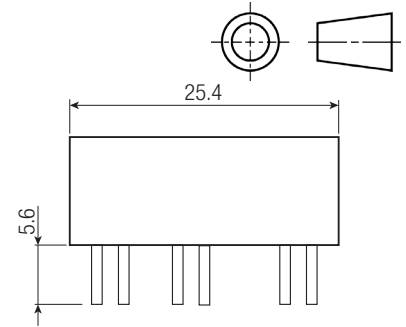
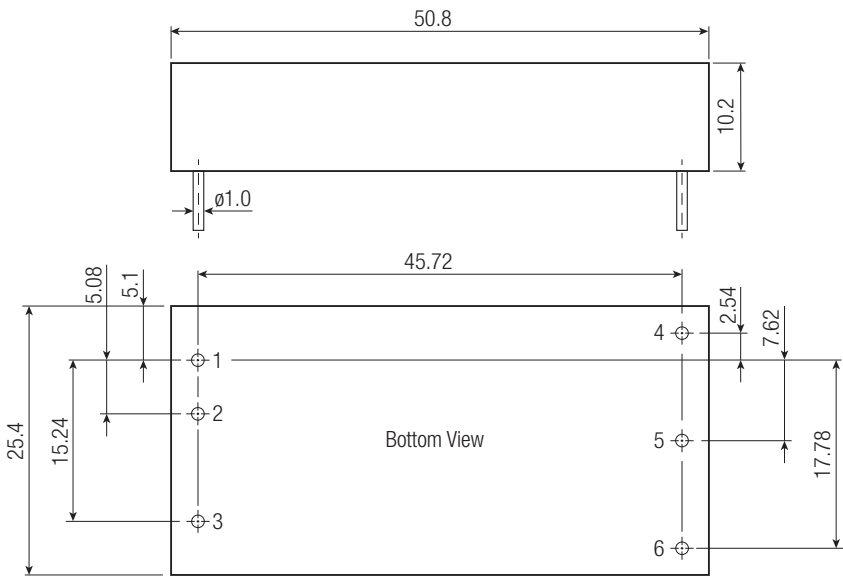

Dimension Drawing with Heat-sink (mm)

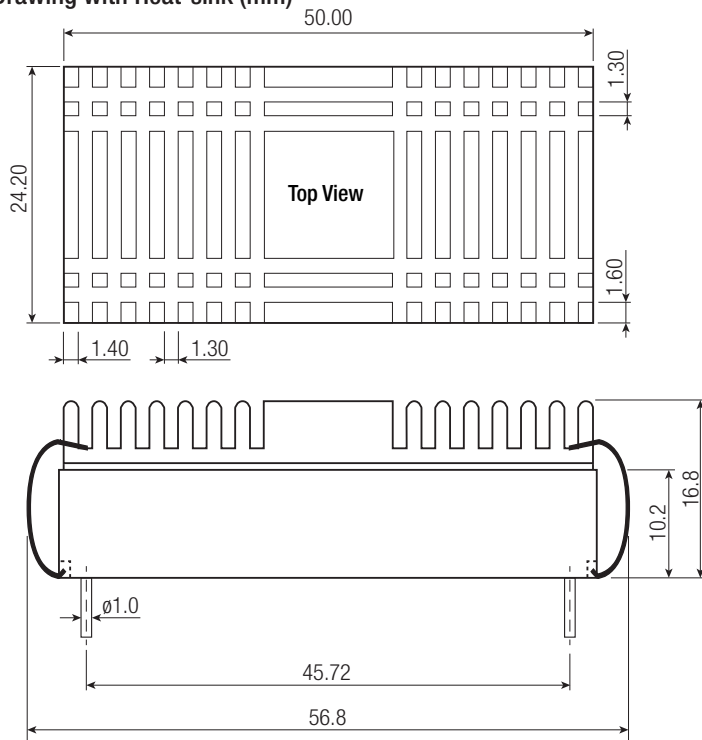

Pin Connections

Pin #	Single	Dual
1	+Vin	+Vin
2	-Vin	-Vin
3	CTRL	CTRL
4	+Vout	+Vout
5	-Vout	Com
6	Trim	-Vout

Pin Pitch Tolerance $\pm 0.25\text{mm}$
Pin dimension tolerance $\pm 0.1\text{mm}$
XX.X $\pm 0.5\text{mm}$
XX.XX $\pm 0.25\text{mm}$

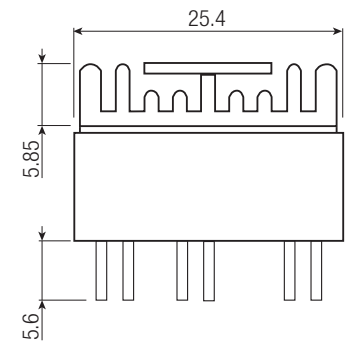

PACKAGING INFORMATION

Parameter	Type	Value
Packaging Quantity	without Heat-sink	9pcs
	with Heat-sink	20pcs
Storage Temperature Range		-55°C to +125°C
Storage Humidity		5% - 95% RH

The product information and specifications are subject to change without prior notice. RECOM products are not authorized for use in safety-critical applications (such as life support) without RECOM's explicit written consent. A safety-critical application is defined as an application where a failure of a RECOM product may reasonably be expected to endanger or cause loss of life, inflict bodily harm or damage property. The buyer shall indemnify and hold harmless RECOM, its affiliated companies and its representatives against any damage claims in connection with the unauthorized use of RECOM products in such safety-critical applications.