



The engineer's choice

ebmpapst

4414/2HHP

INDEX

1	General	3
2	Mechanics	3
2.1	General	3
2.2	Connections	3
3	Operating Data	4
3.1	Operating Data - Electrical Interface - Input	4
3.2	Electrical Operating Data	5
3.3	Operating Data - Electrical Interface -Output	5
3.4	Electrical Features	7
3.5	Aerodynamic	8
3.6	Sound Data	8
4	Environment	9
4.1	General	9
4.2	Climatic requirements*).....	9
5	Safety	10
5.1	Electrical Safety	10
5.2	Approval Tests	10
6	Reliability	10
6.1	General	10

1 General

Fan type	Fan	
Rotational direction looking at rotor	clockwise	
Airflow direction	Air outlet over struts	
Bearing system	Ball bearing	
Mounting position	any	

2 Mechanics

2.1 General

Width	119,0 mm	
Height	119,0 mm	
Depth	38,0 mm	
Weight	0,270 kg	
Housing material	Plastic	
Impeller material	Plastic	
Max. torque when mounted across both mounting flanges	wire outlet corner: 80 Ncm remaining corners: 80 Ncm	
Screw size	ISO 4762 - M4 degreased, without an additional brace and without washer	

2.2 Connections

Electrical connection	Wires	
Length of lead wire	310 mm	
Tolerance	+ - 10,0 mm	
Wire gauge (AWG)	24	
Insulation diameter	1,10 mm	
Contact	see drawing	

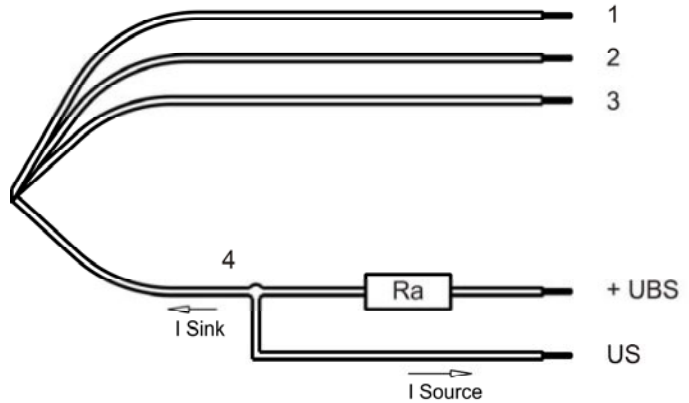

	Colour	Operation
Wire 1	red	+ UB
Wire 2	blue	- GND
Wire 3	violet	PWM
Wire 4	white	Tacho

The auxiliaries shown on the schematic diagram (which are required for the intended use) are not part of our delivery.

3 Operating Data

3.1 Operating Data - Electrical Interface - Input

Control input	PWM
---------------	-----

Features

Input type	Open collector	
PWM - Frequency		1 kHz - 10 kHz Typical: 5 kHz

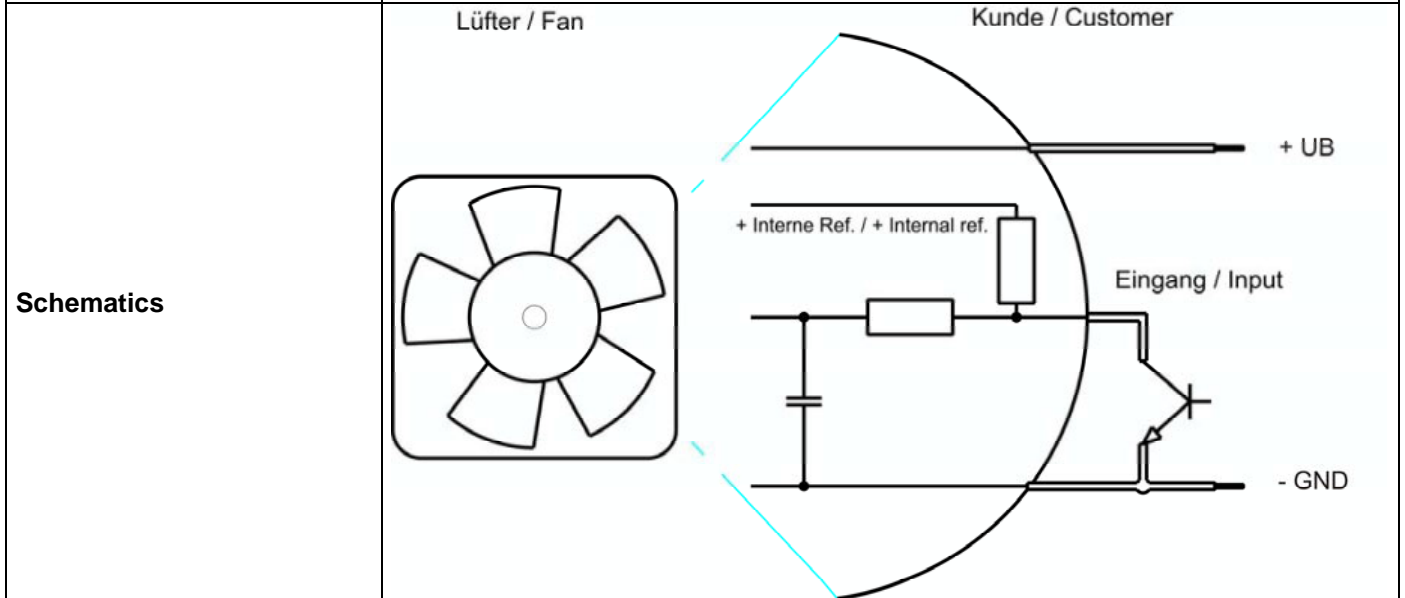
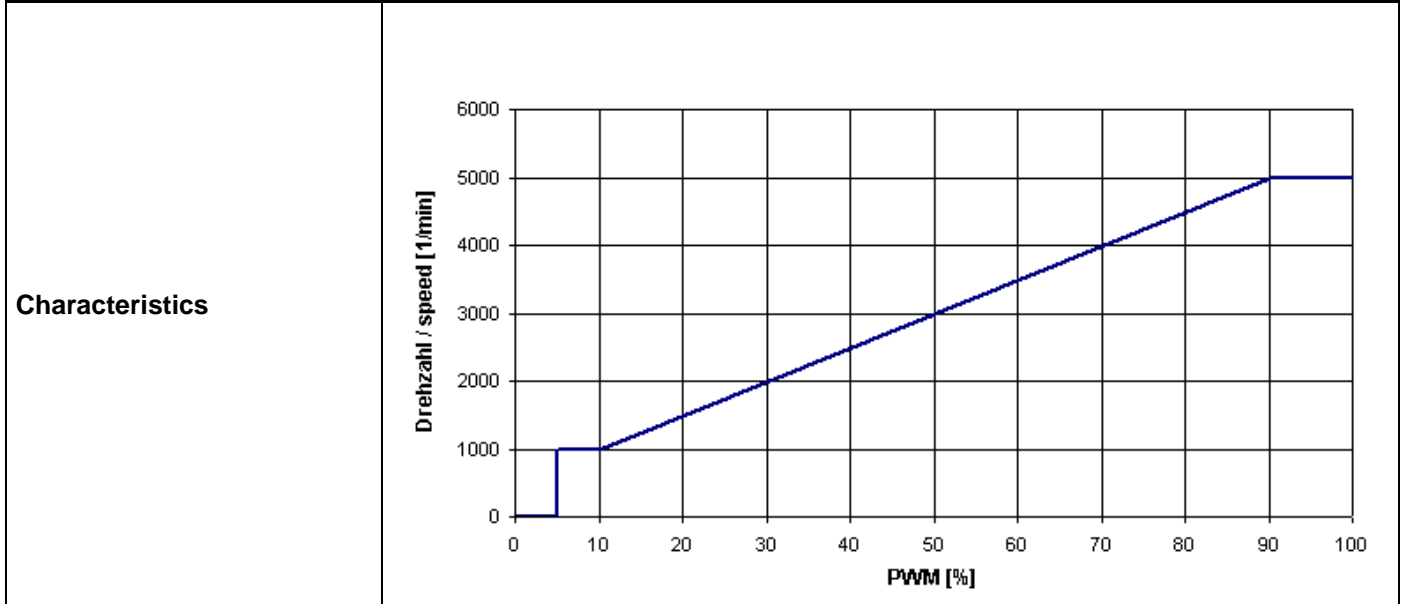

3.2 Electrical Operating Data

Measurement conditions: Normal air density = 1,2 kg/m³; Temperature 23°C +/- 3°C; Motor axis horizontal; warm-up time before measuring 5 minutes (unless otherwise specified). In the intake and outlet area should not be any solid obstruction within 0,5 m.

Δp = 0: corresp. to free air flow (see section 3.5)
 I: corresp. to arithm. mean current value

Name	Condition
PWM 0001	PWM: 100 %;

Features	Condition	Symbol	Values		
Voltage range	Δp = 0	U	18,0 V		28,0 V
Nominal voltage	Δp = 0	U _N		24,0 V	
Power consumption	Δp = 0	P	7,3 W	11,6 W	11,8 W
Tolerance	PWM 0001		+/- 17,5 %	+/- 25,0 %	+/- 25,0 %
Current consumption	Δp = 0	I	405 mA	485 mA	420 mA
Tolerance	PWM 0001		+/- 17,5 %	+/- 25,0 %	+/- 25,0 %
Speed	Δp = 0	n	4.300 1/min	5.000 1/min	5.000 1/min
Tolerance	PWM 0001		+/- 12,5 %	+/- 3,0 %	+/- 3,0 %
Starting current consumption				2.750 mA	

3.3 Operating Data - Electrical Interface -Output

Tacho type	/2 (Open collector)
------------	---------------------

Signal-Ausgangsspannung / Signal output voltage

$$R_a = \frac{U_{BS} - U_{S \text{ Low}}}{I_{\text{Sink}}}$$

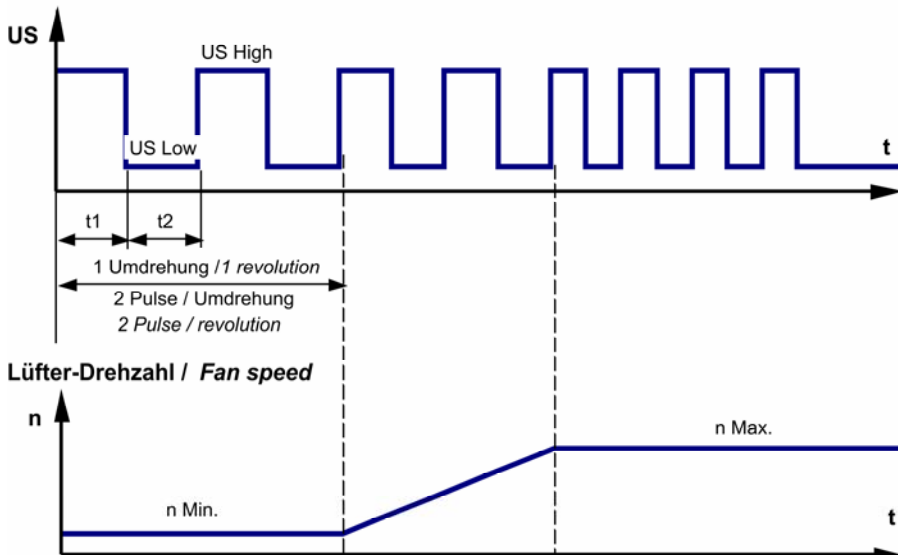

Features	Note	Values
Tacho operating voltage (UBS)		60 V
Tacho signal Low	I sink: 2 mA	<= 0,4 V
Tacho signal High	I source: 0 mA	60 V
Maximum sink current		<= 4 mA

External resistor	External resistor Ra from UBS to US required. All voltages measured to GND.	
Tacho frequency	$(2 \times n) / 60$	
Tacho isolated from motor	No	
Slew rate		=> 0,5 V/us

Alarm type	None
------------	------

3.4 Electrical Features

Electronic function	Speed-Controlled	
Reversed polarity protection	Rectifying diode	
Max. residual current at U_n	$I_F \leq 100 \mu A$	
Locked rotor protection	Auto restart	
Locked rotor current at U_n	approx. 2.750 mA	
Clock signal t_3/t_4 at locked rotor	Typical: 0,25 s / 20 s	

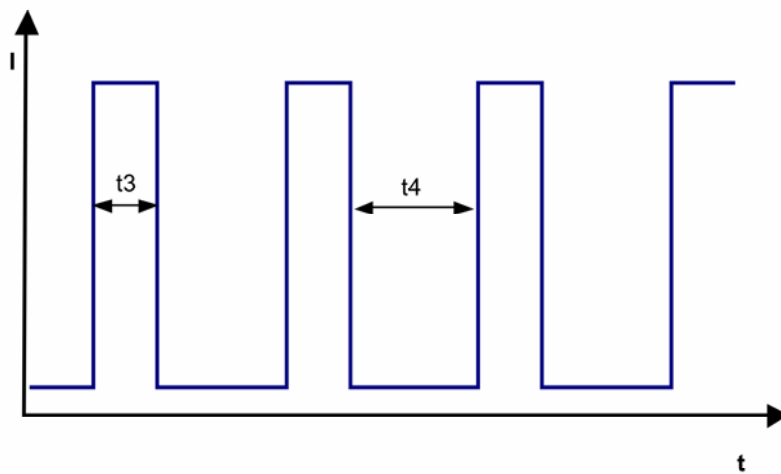

3.5 Aerodynamic

Measurement conditions: Measured with a double chamber intake rig acc. to DIN EN ISO 5801.
Normal air density = 1,2 kg/m³; Temperature 23°C +/- 3°C;
In the intake and outlet area should not be any solid obstruction within 0,5 m.

a.) Operation condition:

5.000 1/min at free air flow	PWM 100 %;		
------------------------------	------------	--	--

Max. free-air flow ($\Delta p = 0 / \dot{V} = \max.$)	280,0 m ³ /h	
Max. static pressure ($\Delta p = \max. / \dot{V} = 0$)	190 Pa	

3.6 Sound Data

Measurement conditions: Sound pressure level: 1 Meter distance between microphone and the air intake.
Sound power level: Acc. to DIN 45635 part 38 (ISO 10302)
Measured in a semianchoic chamber with a background noise level of L_p(A) < 5 dB(A)
For further measurement conditions see section 3.5

a.) Operation condition:

5.000 1/min at free air flow	PWM 100 %	PWM min.:	PWM max.:
------------------------------	-----------	-----------	-----------

Optimal operating point	170,0 m ³ /h @ 81 Pa	
Sound power level at the optimal operating point	6,4 bel(A)	
Sound pressure level at free air flow, measured in rubber bands	55,0 dB(A)	

4 Environment

4.1 General

Min. permitted ambient temperature TU min.	-20 °C	
Max. permitted ambient temperature TU max.	70 °C	
Min. permitted storage temperature TL min.	-40 °C	
Max. permitted storage temperature TL max.	80 °C	

4.2 Climatic requirements*)

Humidity requirements	humid heat, constant; according to DIN EN 60068-2-78, 14 days	
Water exposure	None	
Radiation exposure	None	
Dust requirements	None	
Salt fog requirements	None	
Harmful gas requirements	None	

*) Permitted application area:

The product is intended for use in sheltered rooms with controlled temperature and controlled humidity. Directly exposure to water must be avoided.

Pollution degree 1 (according DIN EN 60664-1)

There is either no pollution or it occurs only dry, non-conductive pollution. The pollution has no negative impact.

5 Safety

5.1 Electrical Safety

Dielectric strength DIN EN 60950 (VDE 0805) and DIN EN 60335 (VDE 0700) A.) Type test Measuring conditions: After 48h of storage at 95% R.H. and 25°C. No arcing or breakdown is allowed! All connections together to ground. B.) Routine test Measuring conditions: At indoor climate. No arcing or breakdown is allowed! All connections together to ground.	500 VAC / 1 Min. 500 VAC / 1 Sec.	
Isolation resistance Measuring conditions: After 48h of storage at 95% R.H. and 25°C measured with U=500 VDC for 1 min.	RI > 10 MOhm	
Air and leakage distances	1,0 mm / 1,2 mm	
Protection class	III	

5.2 Approval Tests

CE	Yes
UL	Yes / UL audited by CSA according to UL507, Electric Fans
VDE	Yes / Approval acc. to EN 60950 (VDE 0805) - Information technology equipment
CSA	Yes / C22.2 No. 113 Fans and Ventilators
CCC	No

The approval tests are observed to:

U approval max.: 28,0 V @ TU approval max.: 70,0 °C

6 Reliability

6.1 General

Life expectancy L10 at TU = 40 °C	50.000 h	
Life expectancy L10 at TU max.	25.000 h	
Life expectancy L10 Delta (40 °C)	100.000 h	

Quality of this document, and clarity of values and the use or interpretation of this document, does not constitute a warranty. It is the user's responsibility to ensure that the use of this document is in accordance with the applicable laws and regulations.

Information about this document is available in the user manual. Before using this document, please refer to the user manual.

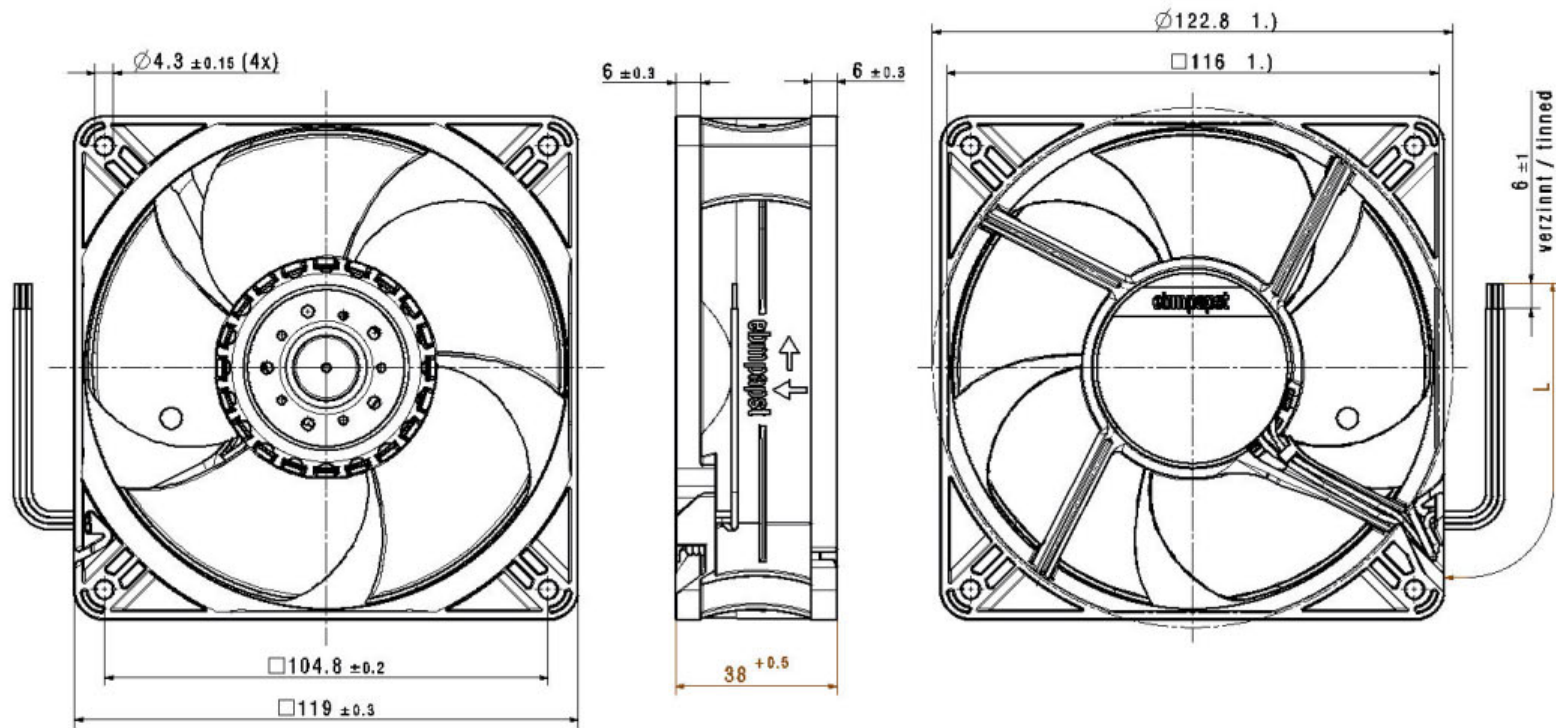

Zeichnung entspricht 3D-Modell:
 Drawing is equivalent to 3D-Model:
 9283510500_CPA_000_A

- A**
- 1.) Maße fuer Montageausschnitt
- max. Anziehdrehmoment = 0.8Nm
 - Axialspiel: mit Feder spielfrei verspannt
 - Anzahl und Länge der Litzen siehe BV- Bl. 1
- A**
- 1.) measures for mounting cut-out
- max. tightening torque = 0.8Nm
 - without axial clearance by a pre-loaded spring
 - length and number of wires see design specification page 1

MP-Status/Status 		GEM.-Nr./ Drawing No.	GEM.-Gehör-/Hör- GEM. System-Verf.	GEM.-Gehör-/Hör- GEM. System-Verf.	Material / Material: Volume / Volume (cm³): Masse / Mass (g):
Toleranzang. / Tolerances: 		Datum / Name		Artikel / Title:	
Allg.eigenschaften / gen. Tolerances:		Zeichn.-Nr. / Drawing No.		Dr.-F. Zeich. / Revision:	
ebmpapst		ebmpapst		Zeichn.-Nr. / Drawing No.	
ebmpapst St. Georgen 6661 A G 80		Tel./Anrufcenter (+49) 170 94 94 94		Form / Size: 119x119x38 Material/Date: 2:1	