



November 2014



MDB10SV — 1.2 A, 1000 V, Micro-DIP, Single-Phase Bridge Rectifier

MDB10SV

1.2 A, 1000 V, Micro-DIP, Single-Phase Bridge Rectifier

Features

- Optimized V_F : 1.015 V Maximum at 1.2 A
- $I_{F(AV)} = 1.2 A$
- $I_{FSM} = 50 A$
- MDB10SS and MDB10S Socket Compatible
- Glass-Passivated Junctions
- Requires Only 35 mm² of Board Space
- Low Package Profile: 1.45 mm Typical, 1.60 mm Maximum
- RoHS Compliant
- Halogen Free
- Qualified with IR/convection Solder Reflow (J-STD-020) and Wave Soldering (JESD22-A111)

Description

With the ever-pressing need to improve power supply efficiency and reliability, the MDB10SV sets a new standard in small form-factor, efficient, robust, bridge rectifier performance.

The design offers improved efficiency by achieving a 1.2 A V_F of 1.015 V maximum at 25°C. This lower V_F results in cooler and more efficient power supply operation.

The design enhances reliability with a 50 A I_{FSM} rating to absorb high surge currents, improved I^2t ratings, and supporting a rated breakdown voltage of 1000 V.

Finally, the MDB10SV achieves all this in a small form-factor micro-DIP package, offering a maximum height of 1.6 mm, and requiring only 35 mm² of board space.

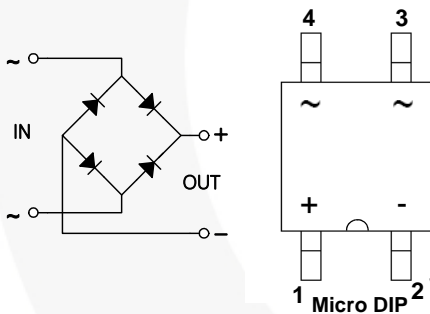

Ordering Information

Part Number	Top Mark	Package	Packing Method
MDB10SV	MDB10V	Micro DIP	Tape and Reel

Absolute Maximum Ratings

Stresses exceeding the absolute maximum ratings may damage the device. The device may not function or be operable above the recommended operating conditions and stressing the parts to these levels is not recommended. In addition, extended exposure to stresses above the recommended operating conditions may affect device reliability. The absolute maximum ratings are stress ratings only. Values are at $T_A = 25^\circ\text{C}$ unless otherwise noted.

Symbol	Parameter	Value	Unit
V_{RRM}	Maximum Repetitive Peak Reverse Voltage	1000	V
V_{RMS}	Maximum RMS Voltage	700	V
V_{DC}	Maximum DC Blocking Voltage	1000	V
$I_{F(AV)}$	Average Rectified Forward Current ⁽¹⁾	1.2	A
I_{FSM}	Peak Forward Surge Current ⁽²⁾	50	A
I^2t	I^2t Rating for Fusing ($t < 8.3$ ms)	10.4	A ² S
T_J	Operating Junction Temperature Range	-55 to +150	$^\circ\text{C}$
T_{STG}	Storage Temperature Range	-55 to +150	$^\circ\text{C}$

Notes:

- 8.3 ms single half-sine wave, R-load, $T_A = 25^\circ\text{C}$.
- 8.3 ms single half-sine wave, single pulse, $T_J = 25^\circ\text{C}$, compliant with MIL standard.

Thermal Characteristics⁽³⁾

Symbol	Parameter	Conditions	Max.	Unit
$R_{\theta JA}$	Thermal Resistance, Junction to Ambient	Multi-Die Measurement (Maximum Land Pattern: 12 x 12 mm)	55	$^\circ\text{C/W}$
		Multi-Die Measurement (Minimum Land Pattern: 0.95 x 1.65 mm)	115	
ψ_{JL}	Thermal Characterization Parameter, Junction to Lead	Single-Die Measurement (Maximum and Minimum Land Pattern)	18	$^\circ\text{C/W}$

Note:

- The thermal resistances ($R_{\theta JA}$ & ψ_{JL}) are characterized with the device mounted on the following FR4 printed circuit boards, as shown in Figure 1 and Figure 2. PCB size: 76.2 x 114.3 mm.

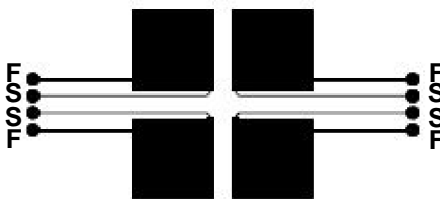

Figure 1. Maximum Pads of 2 oz Copper

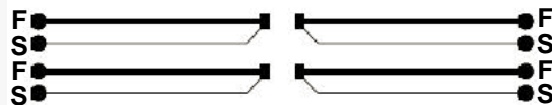

Figure 2. Minimum Pads of 2 oz Copper

Electrical Characteristics

Values are at $T_A = 25^\circ\text{C}$ unless otherwise specified.

Symbol	Parameter	Conditions	Value		Unit	
			Typ.	Max.		
V_F	Maximum Forward Voltage	$I_F = 0.3\text{ A}$, 300 μs Pulse, 1% Duty Cycle, Per Diode	0.850		V	
		$I_F = 1.0\text{ A}$, 300 μs Pulse, 1% Duty Cycle, Per Diode	0.930			
		$I_F = 1.2\text{ A}$, 300 μs Pulse, 1% Duty Cycle, Per Diode	0.940	1.015		
I_R	Maximum Reverse Current	At V_{RWM} , Pulse Measurement, Per Diode	$T_A = 25^\circ\text{C}$	0.1	10.0	μA
			$T_A = 125^\circ\text{C}$	95.0		
C_J	Typical Junction Capacitance	$V_R = 4\text{ V}$, $f = 1\text{ MHz}$	14		pF	
t_{rr}	Typical Reverse-Recovery Time	$I_F = 0.5\text{ A}$, $I_{RM} = 1\text{ A}$, $I_{R(REC)} = 0.25\text{ A}$	1430		ns	

Typical Performance Characteristics

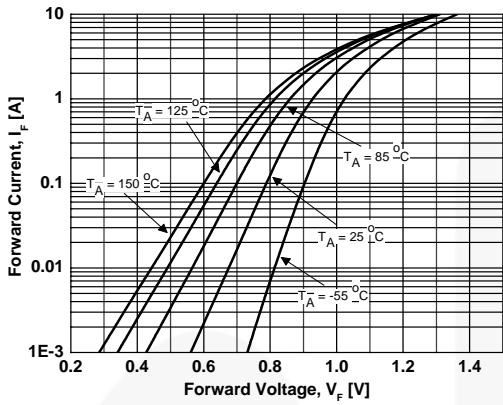

Figure 3. Typical Instantaneous Forward Voltage Per Leg

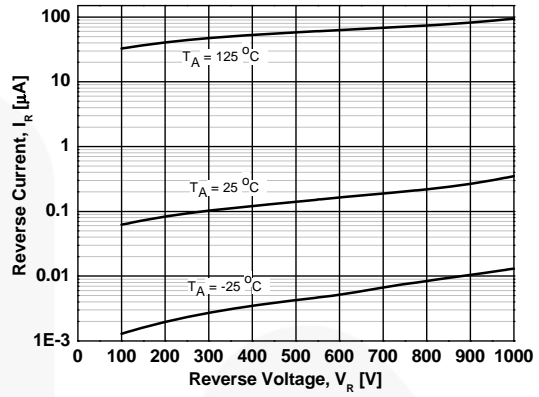

Figure 4. Typical Reverse-Voltage Current Characteristics

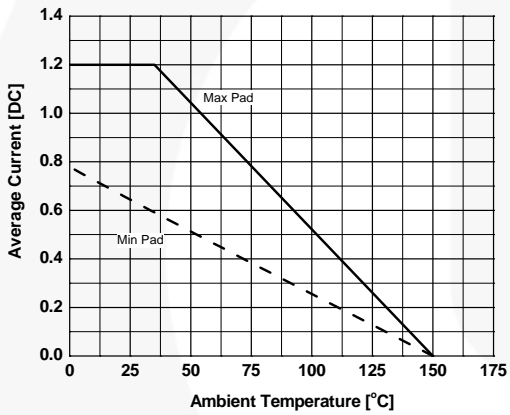

Figure 5. Forward Current Derating Curve

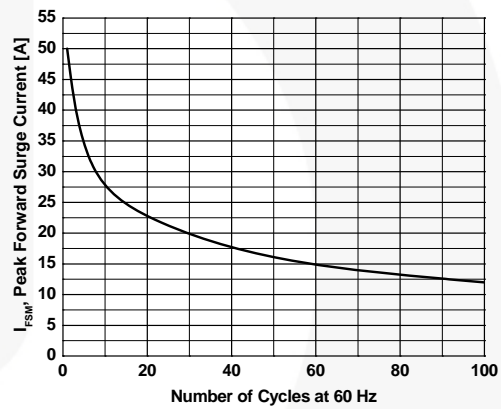

Figure 6. Surge Current Derating Curve

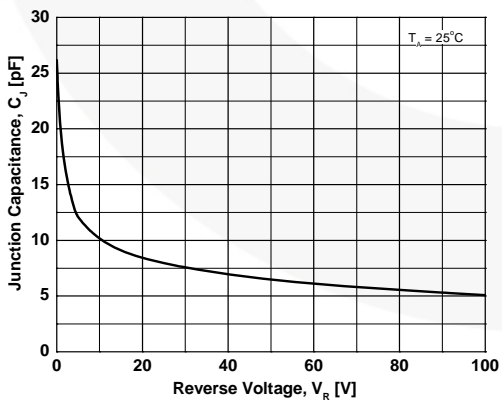
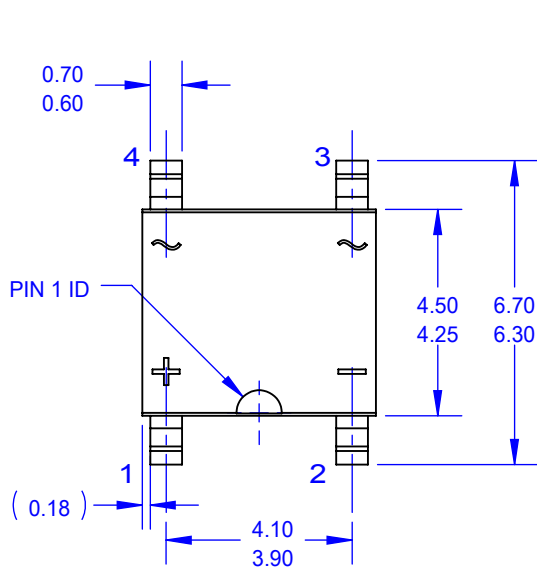
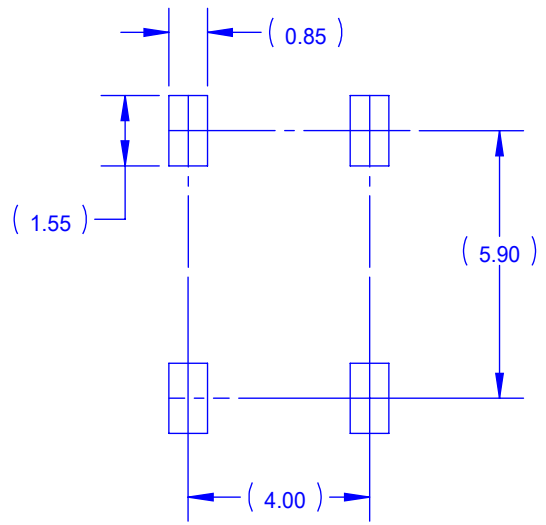

Figure 7. Typical Junction Capacitance



TOP VIEW



LAND PATTERN RECOMMENDATION

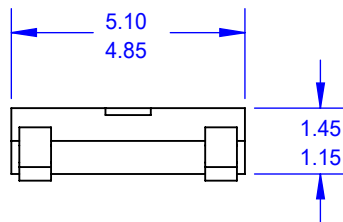

SIDE VIEW

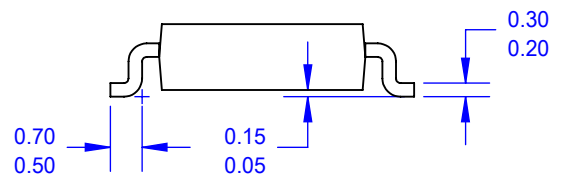

END VIEW

NOTES:

- A. THIS PACKAGE DOES NOT CONFORM TO ANY REFERENCE STANDARD.
- B. ALL DIMENSIONS ARE IN MILLIMETERS.
- C. DIMENSIONS ARE EXCLUSIVE OF BURRS, MOLD FLASH AND TIE BAR PROTRUSIONS.
- G. DRAWING FILE NAME: MKT-TD104BREV1.



TRADEMARKS

The following includes registered and unregistered trademarks and service marks, owned by Fairchild Semiconductor and/or its global subsidiaries, and is not intended to be an exhaustive list of all such trademarks.

- AccuPower™
- AttitudeEngine™
- Awinda®
- AX-CAP®*
- BitSiC™
- Build it Now™
- CorePLUS™
- CorePOWER™
- CROSSVOL™
- CTL™
- Current Transfer Logic™
- DEUXPEED®
- Dual Cool™
- EcoSPARK®
- EfficientMax™
- ESBC™
- F**™
- Fairchild®
- Fairchild Semiconductor®
- FACT Quiet Series™
- FACT®
- FastvCore™
- FETBench™
- FPS™
- F-PFS™
- FRFET®
- Global Power ResourceSM
- GreenBridge™
- Green FPS™
- Green FPS™ e-Series™
- Gmax™
- GTO™
- IntelliMAX™
- ISOPLANAR™
- Making Small Speakers Sound Louder and Better™
- MegaBuck™
- MICROCOUPLER™
- MicroFET™
- MicroPak™
- MicroPak2™
- MillerDrive™
- MotionMax™
- MotionGrid®
- MTi®
- MTx®
- MVN®
- mWSaver®
- OptoHiT™
- OPTOLOGIC®
- OPTOPLANAR®
- ™
- Power Supply WebDesigner™
- PowerTrench®
- PowerXS™
- Programmable Active Droop™
- QFET®
- QS™
- Quiet Series™
- RapidConfigure™
- ™
- Saving our world, 1mW/W/kW at a time™
- SignalWise™
- SmartMax™
- SMART START™
- Solutions for Your Success™
- SPM®
- STEALTH™
- SuperFET®
- SuperSOT™-3
- SuperSOT™-6
- SuperSOT™-8
- SupreMOS®
- SyncFET™
- Sync-Lock™
- ™
- TinyBoost®
- TinyBuck®
- TinyCalc™
- TinyLogic®
- TINYOPTO™
- TinyPower™
- TinyPWM™
- TinyWire™
- TranSiC™
- TriFault Detect™
- TRUECURRENT®*
- μSerDes™
- ™
- UHC®
- Ultra FRFET™
- UniFET™
- VcX™
- VisualMax™
- VoltagePlus™
- XS™
- Xsens™
- 仙童®

* Trademarks of System General Corporation, used under license by Fairchild Semiconductor.

DISCLAIMER

FAIRCHILD SEMICONDUCTOR RESERVES THE RIGHT TO MAKE CHANGES WITHOUT FURTHER NOTICE TO ANY PRODUCTS HEREIN TO IMPROVE RELIABILITY, FUNCTION, OR DESIGN. TO OBTAIN THE LATEST, MOST UP-TO-DATE DATASHEET AND PRODUCT INFORMATION, VISIT OUR WEBSITE AT [HTTP://WWW.FAIRCHILDSEMI.COM](http://www.fairchildsemi.com). FAIRCHILD DOES NOT ASSUME ANY LIABILITY ARISING OUT OF THE APPLICATION OR USE OF ANY PRODUCT OR CIRCUIT DESCRIBED HEREIN; NEITHER DOES IT CONVEY ANY LICENSE UNDER ITS PATENT RIGHTS, NOR THE RIGHTS OF OTHERS. THESE SPECIFICATIONS DO NOT EXPAND THE TERMS OF FAIRCHILD'S WORLDWIDE TERMS AND CONDITIONS, SPECIFICALLY THE WARRANTY THEREIN, WHICH COVERS THESE PRODUCTS.

AUTHORIZED USE

Unless otherwise specified in this data sheet, this product is a standard commercial product and is not intended for use in applications that require extraordinary levels of quality and reliability. This product may not be used in the following applications, unless specifically approved in writing by a Fairchild officer: (1) automotive or other transportation, (2) military/aerospace, (3) any safety critical application – including life critical medical equipment – where the failure of the Fairchild product reasonably would be expected to result in personal injury, death or property damage. Customer's use of this product is subject to agreement of this Authorized Use policy. In the event of an unauthorized use of Fairchild's product, Fairchild accepts no liability in the event of product failure. In other respects, this product shall be subject to Fairchild's Worldwide Terms and Conditions of Sale, unless a separate agreement has been signed by both Parties.

ANTI-COUNTERFEITING POLICY

Fairchild Semiconductor Corporation's Anti-Counterfeiting Policy. Fairchild's Anti-Counterfeiting Policy is also stated on our external website, www.fairchildsemi.com, under Terms of Use

Counterfeiting of semiconductor parts is a growing problem in the industry. All manufacturers of semiconductor products are experiencing counterfeiting of their parts. Customers who inadvertently purchase counterfeit parts experience many problems such as loss of brand reputation, substandard performance, failed applications, and increased cost of production and manufacturing delays. Fairchild is taking strong measures to protect ourselves and our customers from the proliferation of counterfeit parts. Fairchild strongly encourages customers to purchase Fairchild parts either directly from Fairchild or from Authorized Fairchild Distributors who are listed by country on our web page cited above. Products customers buy either from Fairchild directly or from Authorized Fairchild Distributors are genuine parts, have full traceability, meet Fairchild's quality standards for handling and storage and provide access to Fairchild's full range of up-to-date technical and product information. Fairchild and our Authorized Distributors will stand behind all warranties and will appropriately address any warranty issues that may arise. Fairchild will not provide any warranty coverage or other assistance for parts bought from Unauthorized Sources. Fairchild is committed to combat this global problem and encourage our customers to do their part in stopping this practice by buying direct or from authorized distributors.

PRODUCT STATUS DEFINITIONS

Definition of Terms

Datasheet Identification	Product Status	Definition
Advance Information	Formative / In Design	Datasheet contains the design specifications for product development. Specifications may change in any manner without notice.
Preliminary	First Production	Datasheet contains preliminary data; supplementary data will be published at a later date. Fairchild Semiconductor reserves the right to make changes at any time without notice to improve design.
No Identification Needed	Full Production	Datasheet contains final specifications. Fairchild Semiconductor reserves the right to make changes at any time without notice to improve the design.
Obsolete	Not In Production	Datasheet contains specifications on a product that is discontinued by Fairchild Semiconductor. The datasheet is for reference information only.

Rev. I77