



MAKER WORKS TECHNOLOGY INC

No. 426, F/4, Gonglehuating Business Building, Xihu Road,  
Xixiang Sub-district, Bao'an District, Shenzhen, 518102 China.

Please contact with us if you need some  
technique support: [support@makeblock.cc](mailto:support@makeblock.cc)  
[www.makeblock.cc](http://www.makeblock.cc)







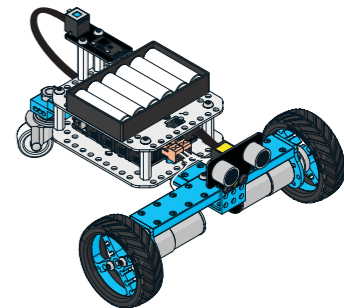
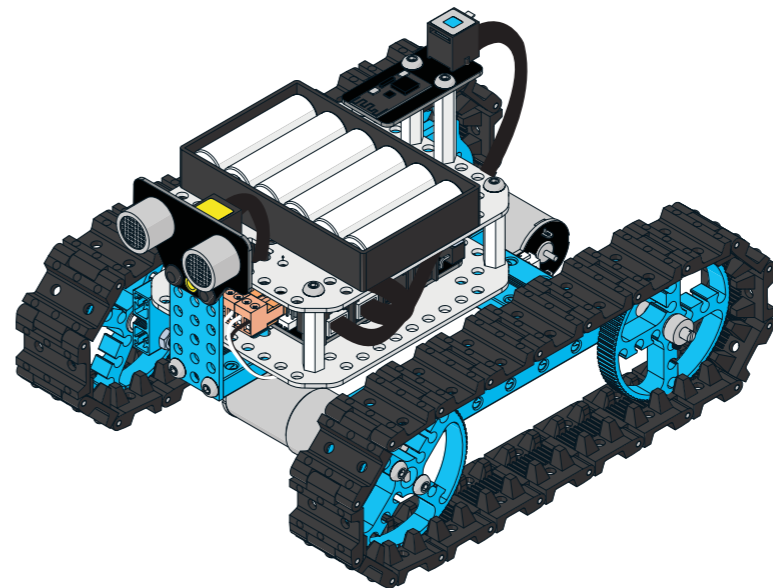

































# Starter Robot Kit **Bluetooth Version**

Robot Tank  
Three-Wheeled Robot Car



# Parts List Pictures for reference only

1× Beam 0824-96		2× Shaft Collar 4mm		6× Nylon Stud M4×30	
1× Beam 0824-128		4× Flange Bearing 4×8×3mm		4× Plastic Rivet R4060	
2× Beam 0824-144		2× BaseBracket		4× Plastic Rivet R4120	
1× Bracket 3×3		1× Battery Holder for (6) AA		4× Plastic Ring 4×7×2mm	
1× Plate 3×6		1× Hex Screwdriver		2× DC Motor-25	
1× Bracket P3		1× Cross Screwdriver		1× Makeblock Orion	
1× Caster Wheel		2× Hex Allen Key		1× Me Ultrasonic Sensor	
2× DC Motor-25 Bracket		1× Wrench		1× Me Bluetooth Module	
2× Shaft Connector 4mm		22× Screw M4×8		1× Micro USB cable	
4× Timing Pulley 90T		14× Screw M4×14		1× 6P6C RJ25 Cable-20cm	
2× Tire 68.5×22mm		3× Nut M4		1× 6P6C RJ25 Cable-35cm	
38× Track		1× Nut M8			
38× Track Axle		4× Headless Set Screw M3×5			
2× Threaded Shaft 4×39mm		4× Screw M3×8			

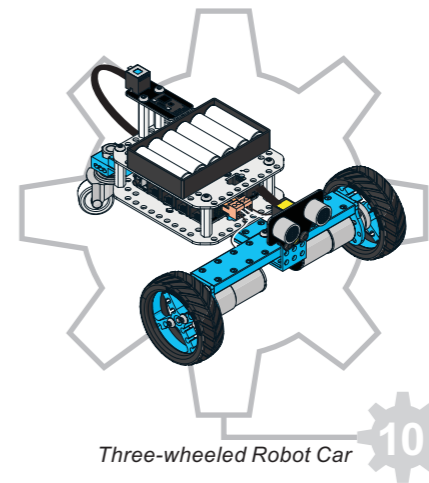
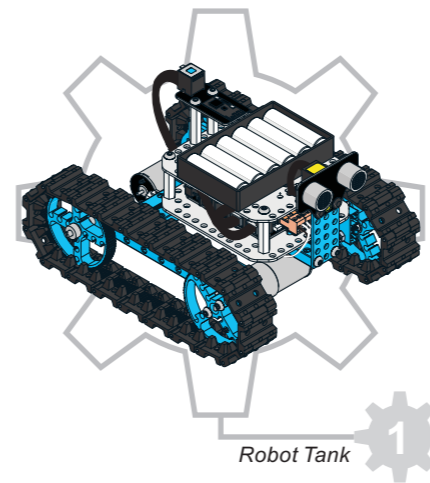

 Please visit <http://learn.makeblock.cc/starter-robot-kit/> to view the programming guide.

# Building the Robot Tank

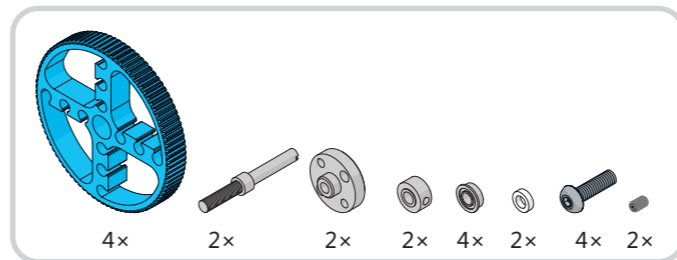
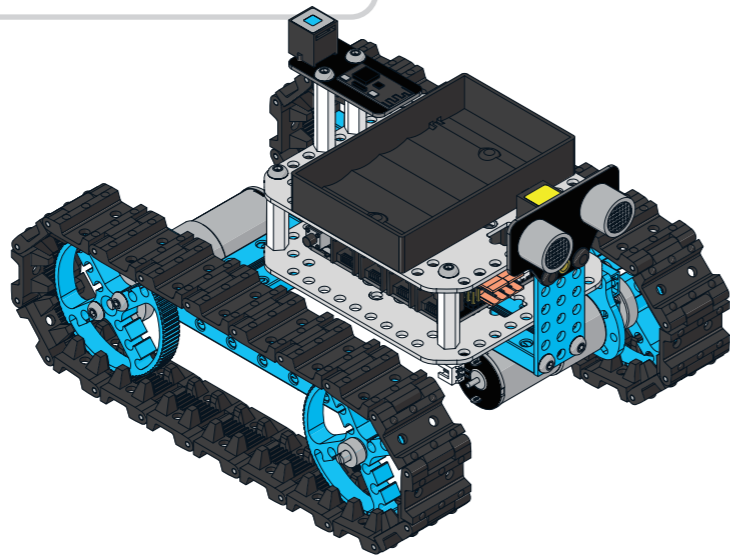
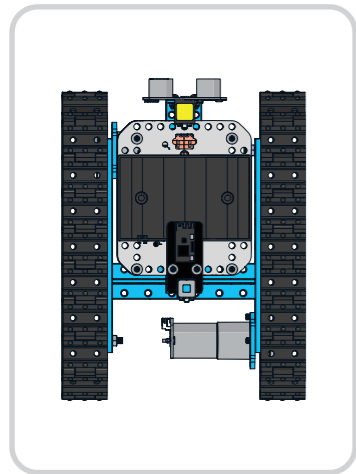
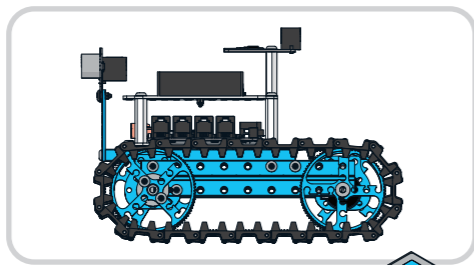
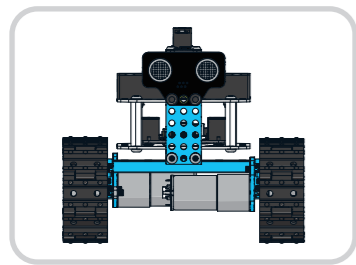

1

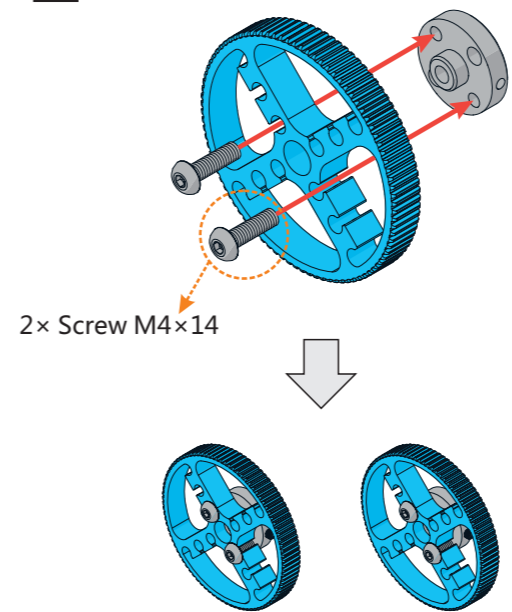

2

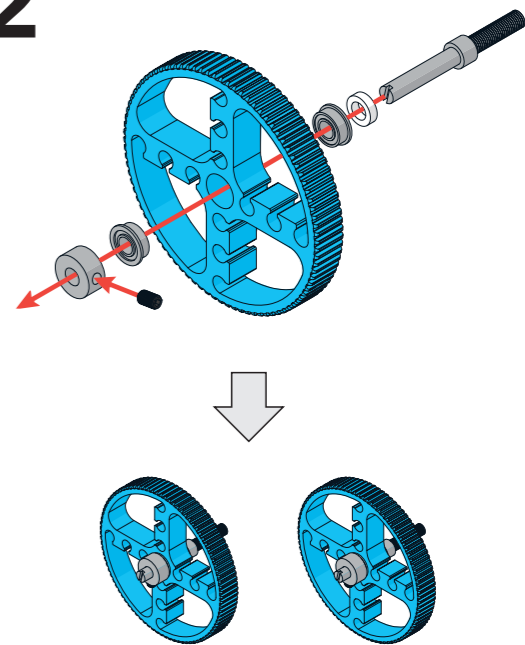

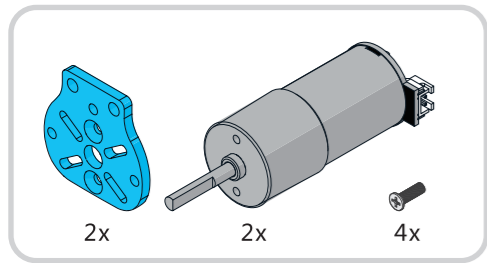

3

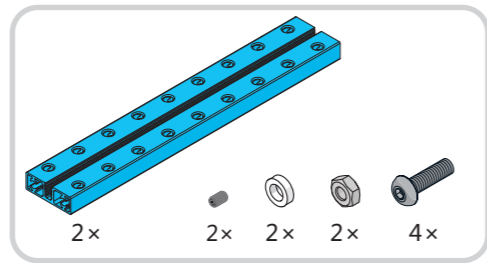
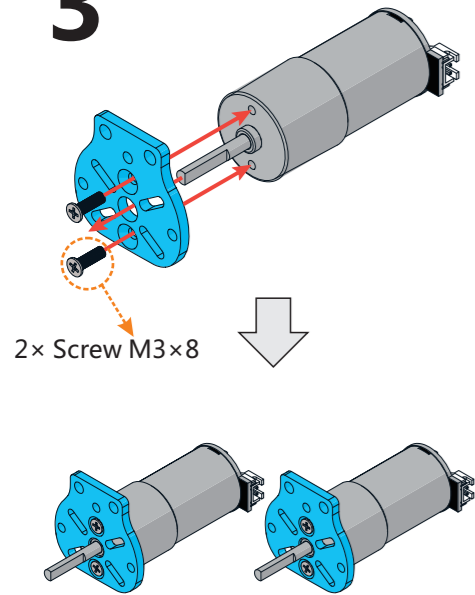

4

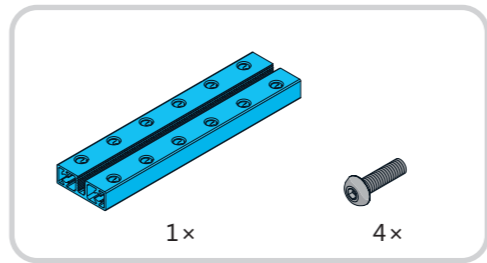
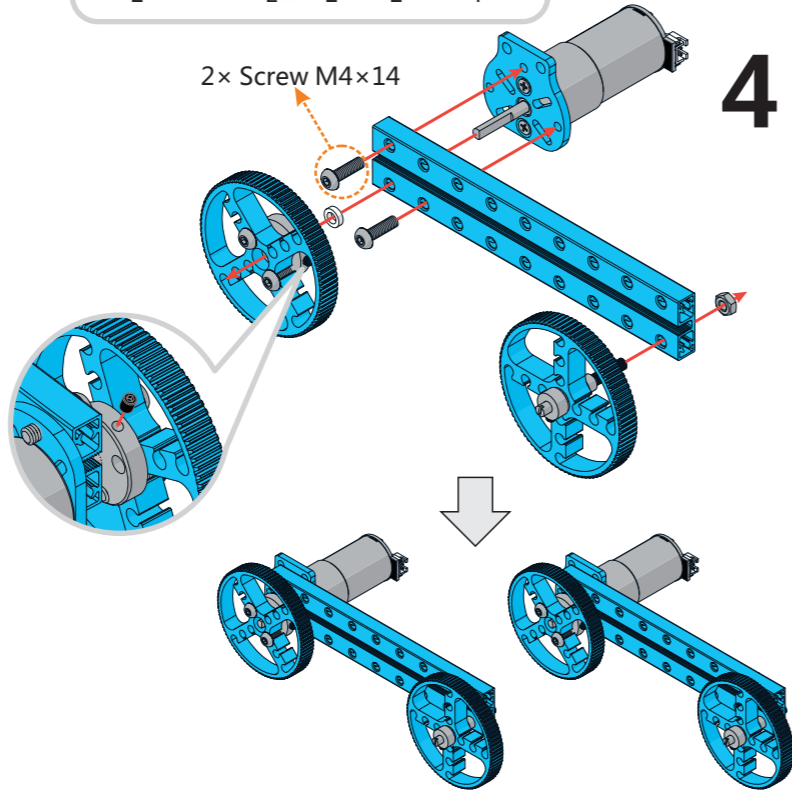

5

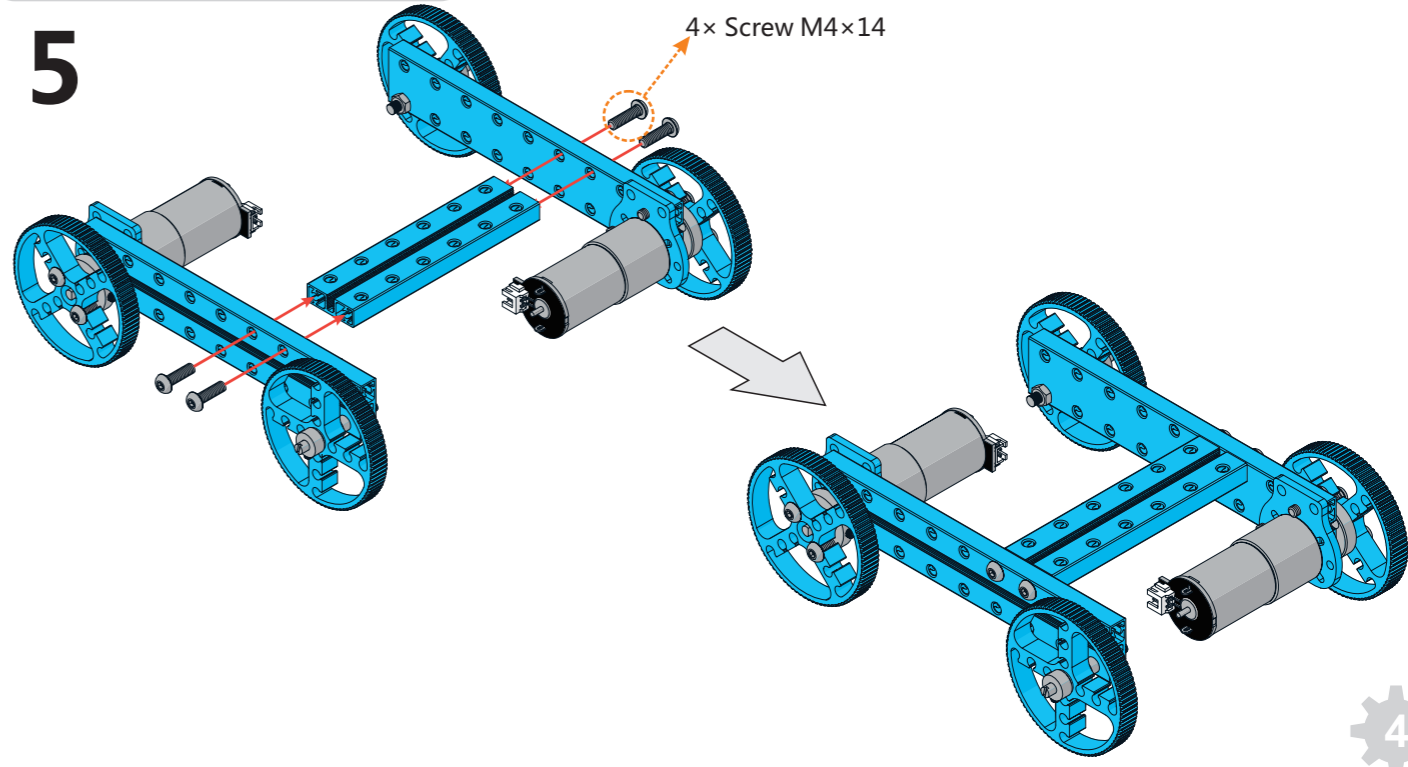



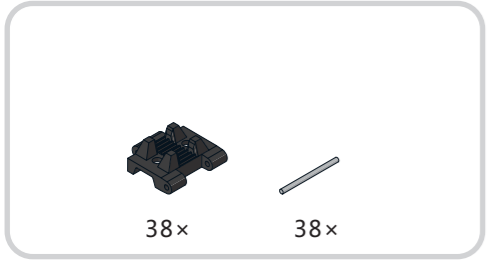

6

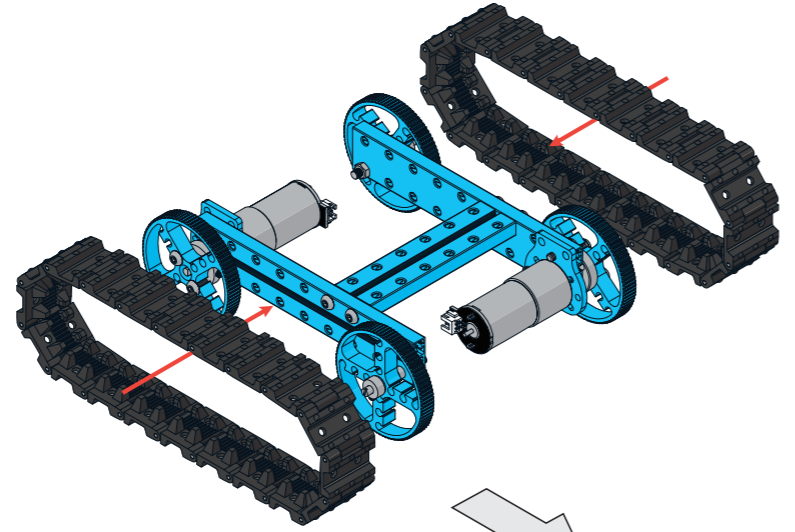
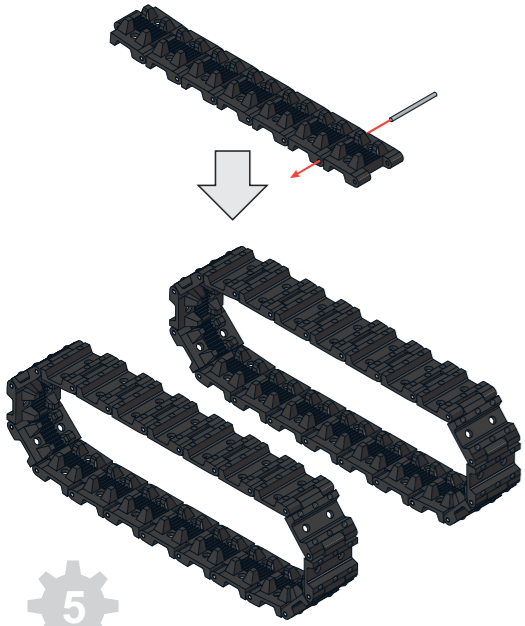

7

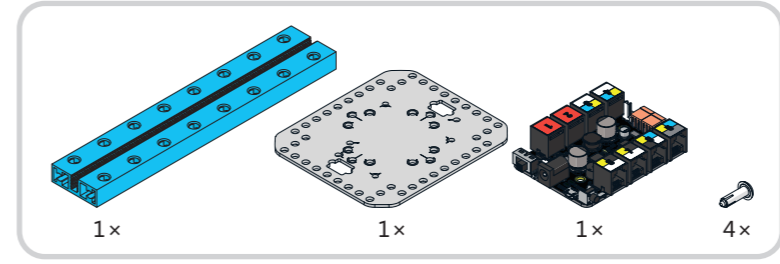
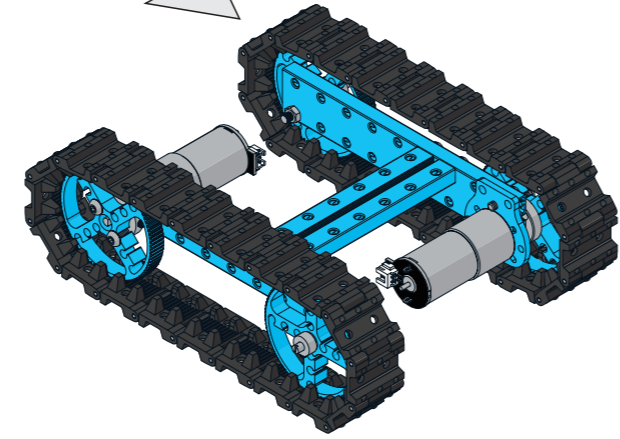

8

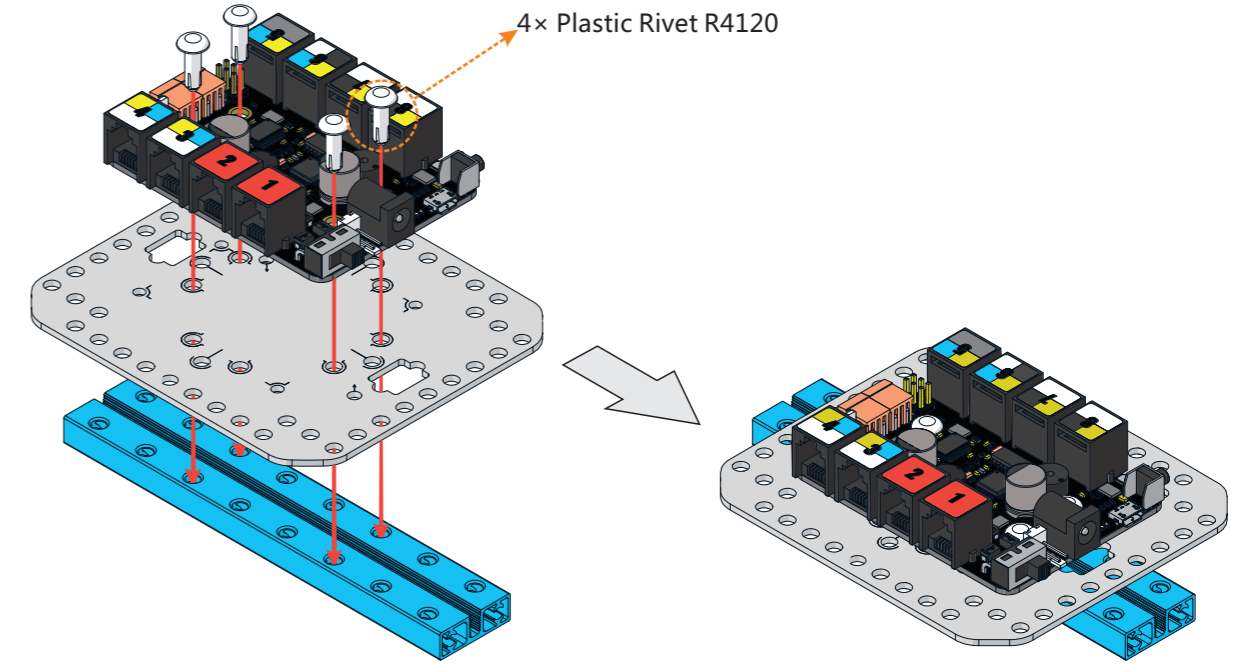

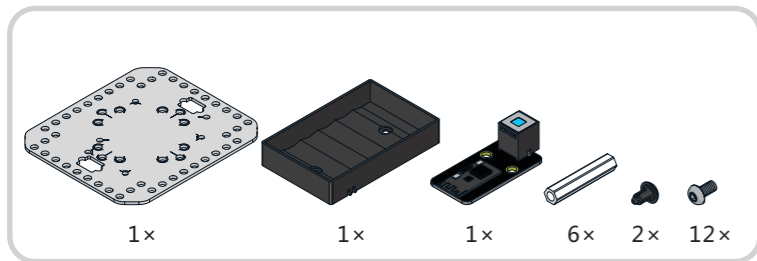

9

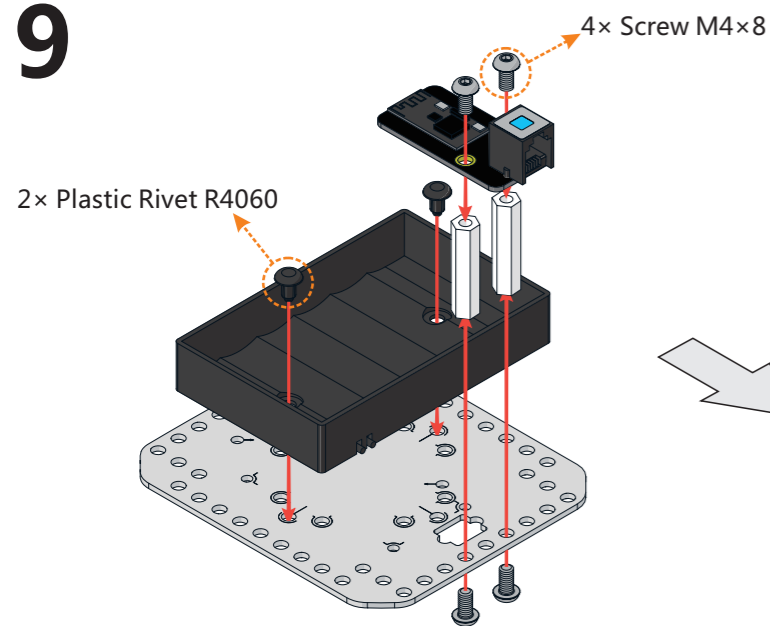

10

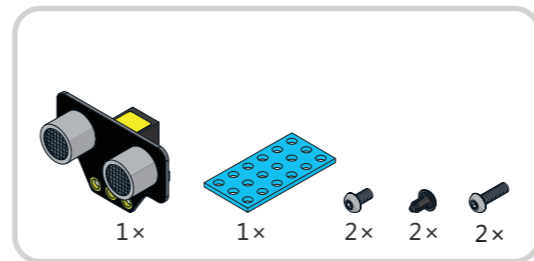
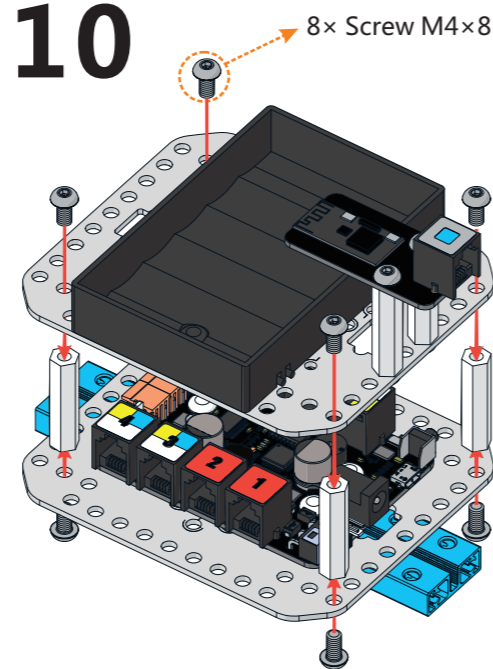

11

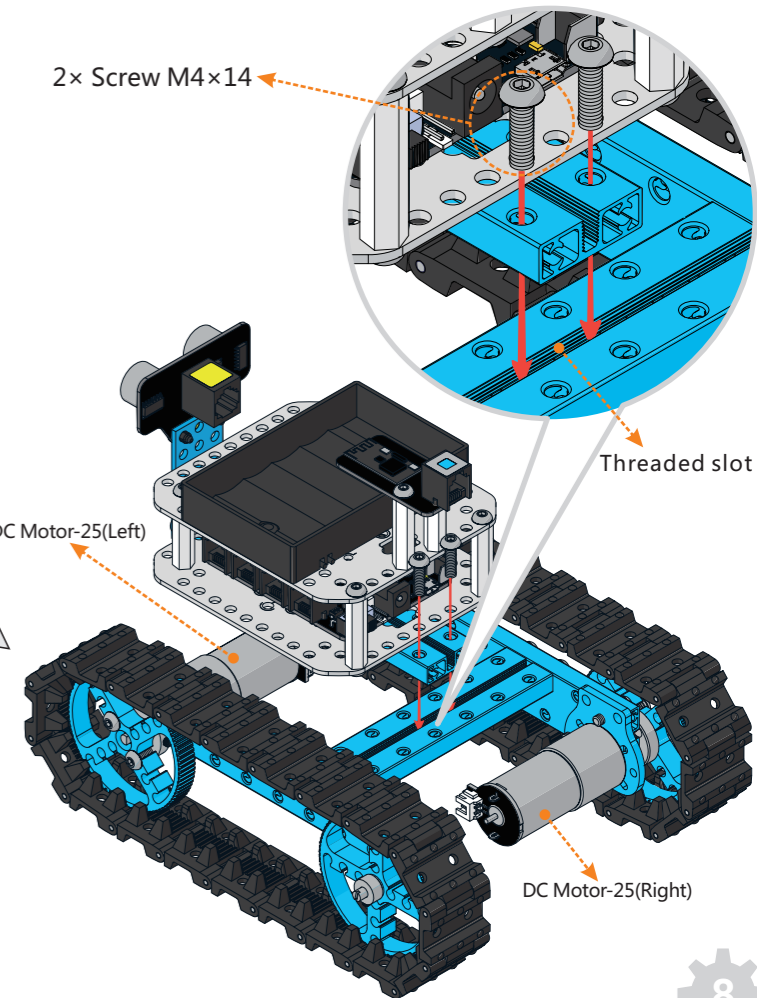
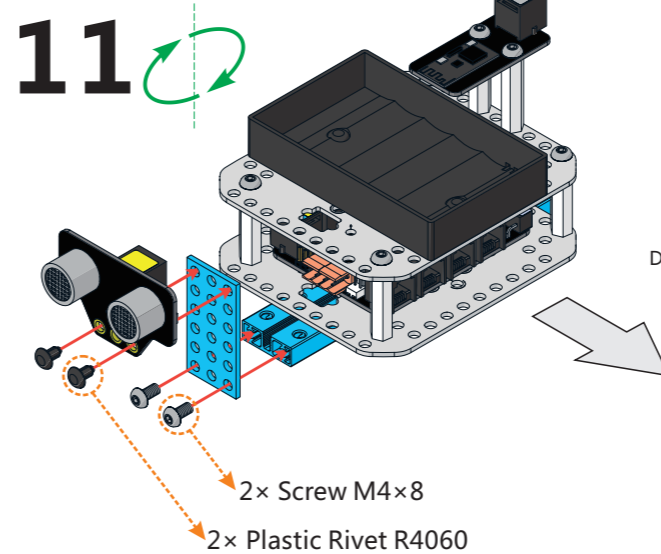

# Wiring and Programming

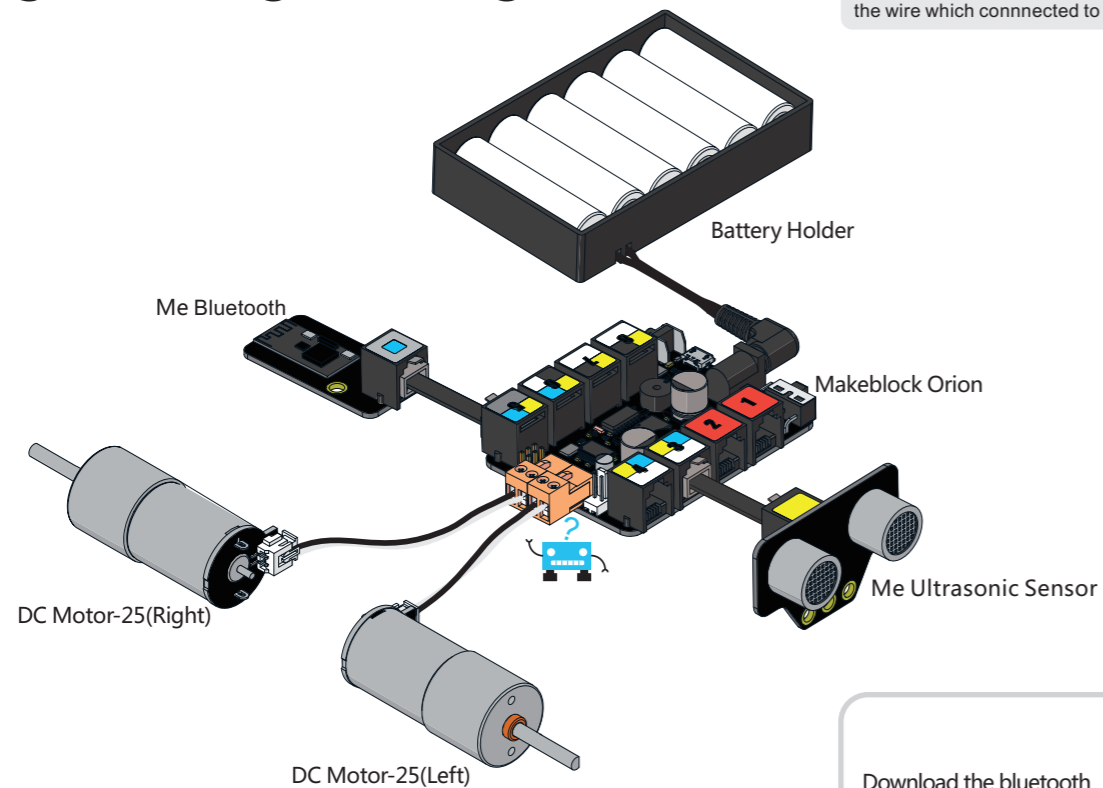

To reduce the electromagnetic interference, Please consider to add the magnetic ring to the wire which connected to motors.

Download the bluetooth control App by scanning the QR code

<http://app.makeblock.cc/>

You may need to switch the order of two wires to correct the rotation direction.

# Building the Three-Wheeled Robot Car

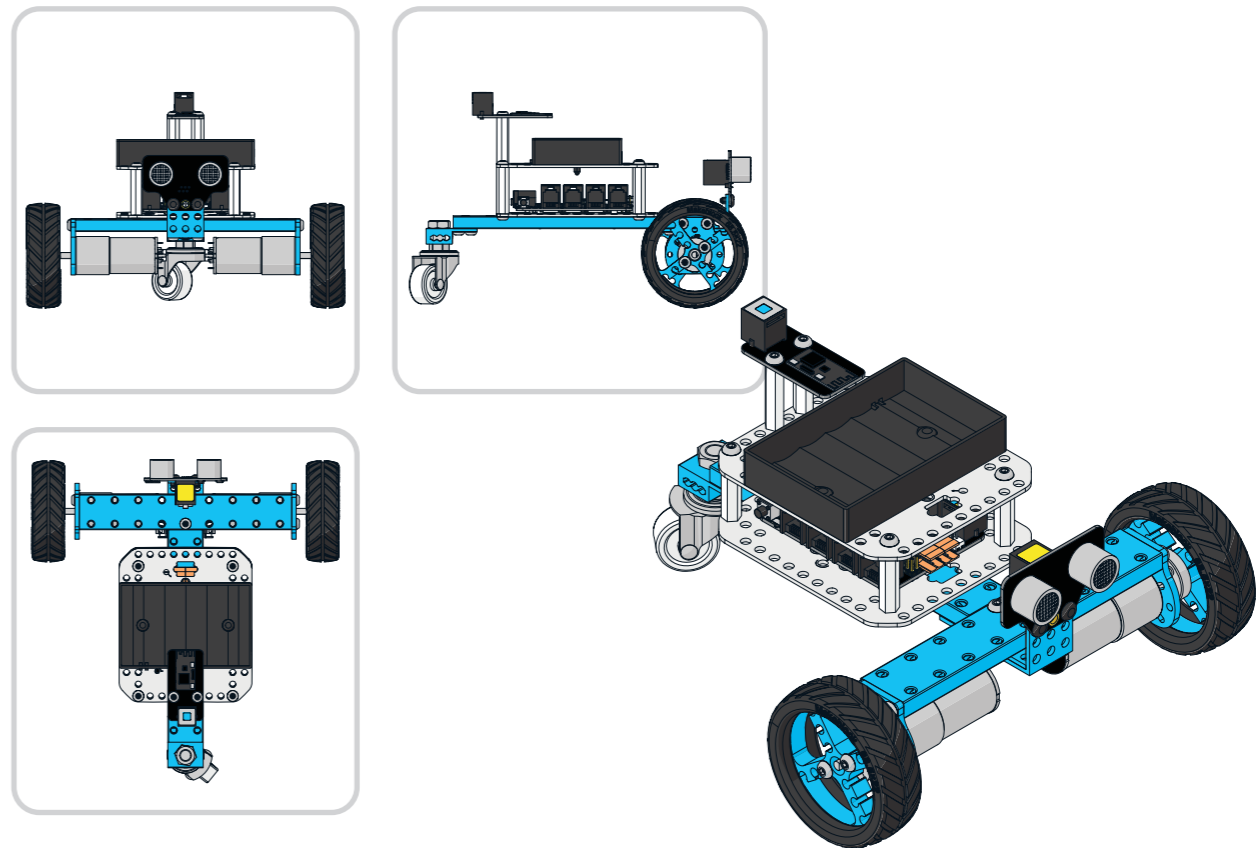

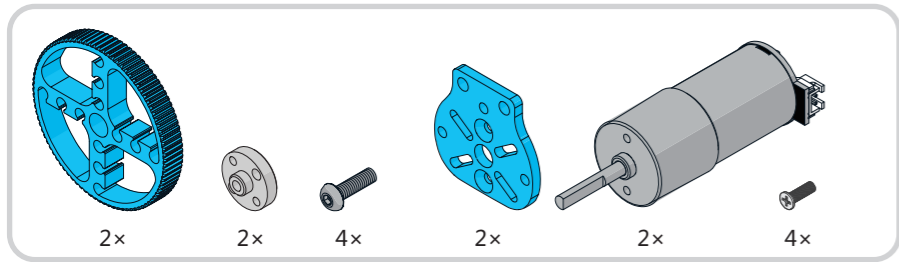

1

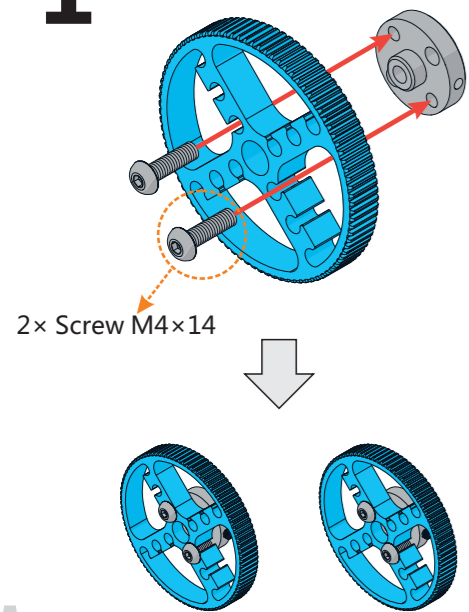

2

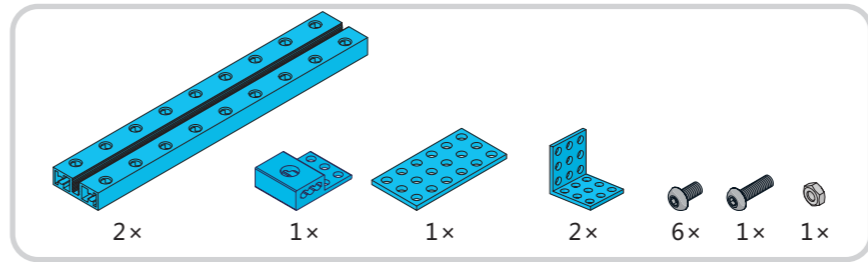
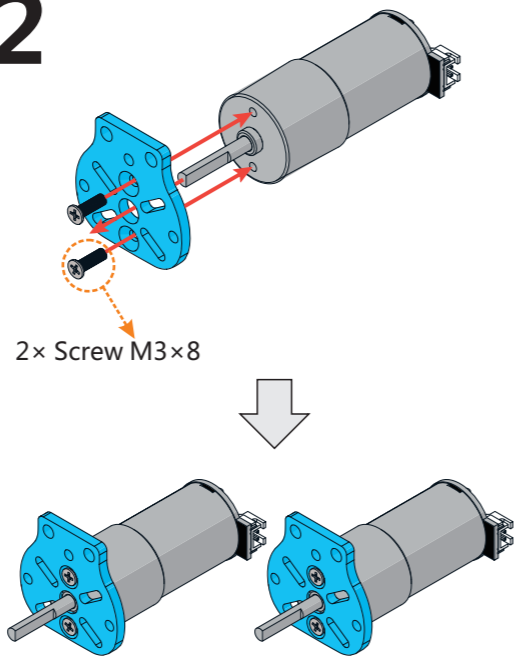

3

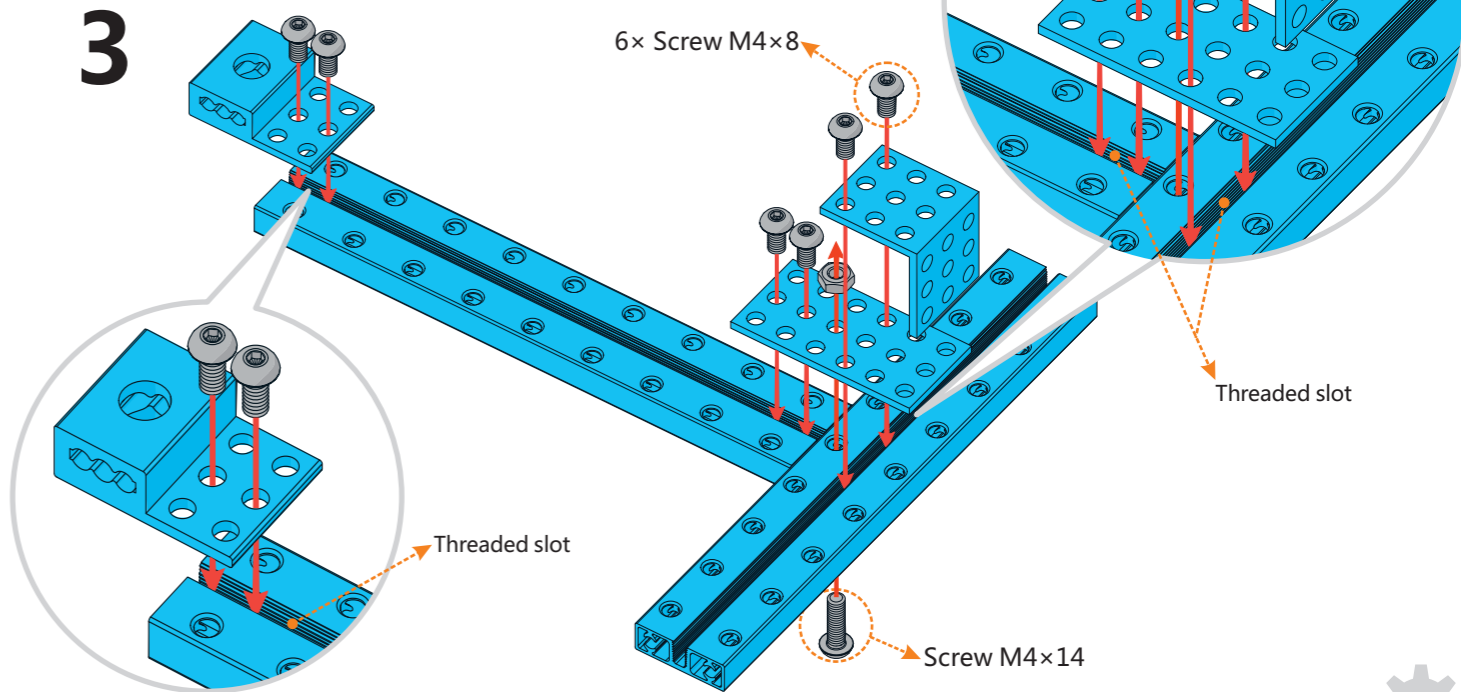





4

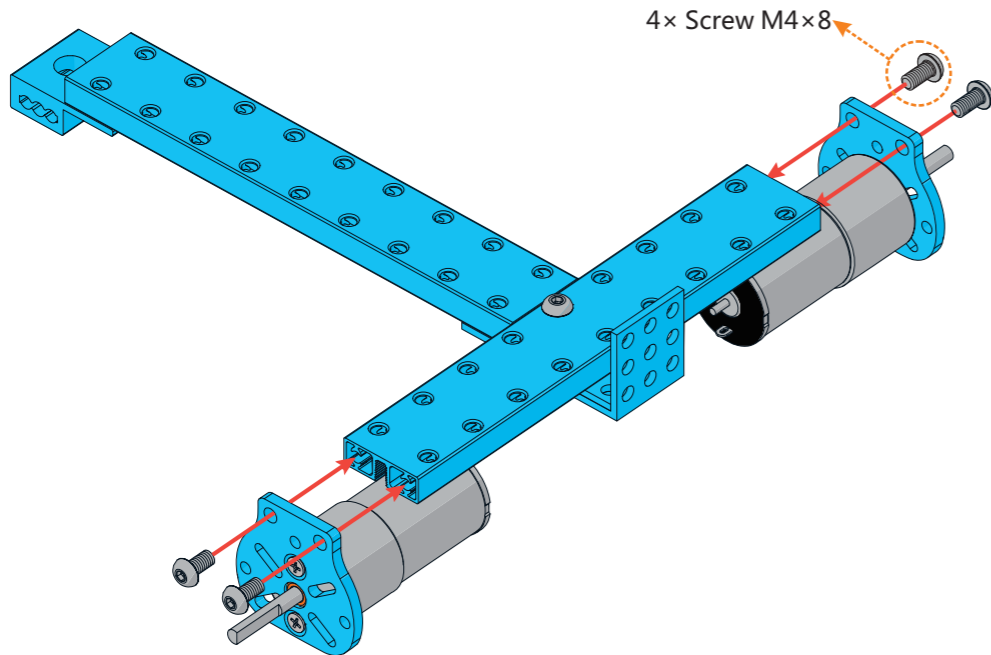

5

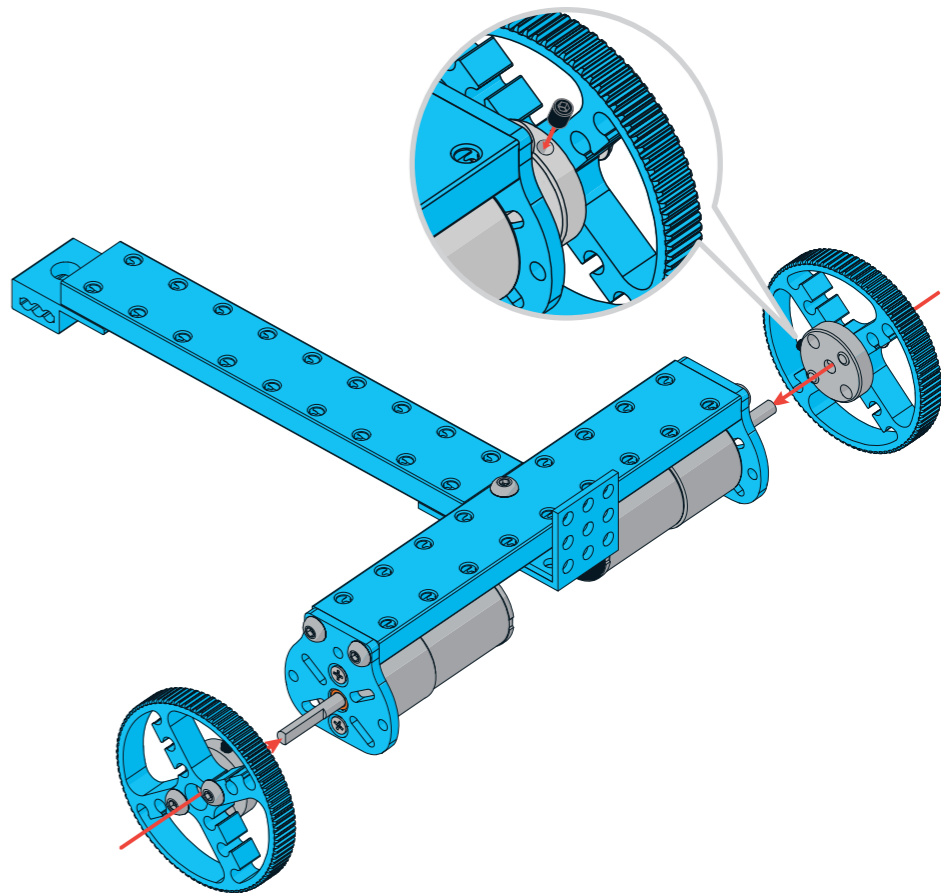



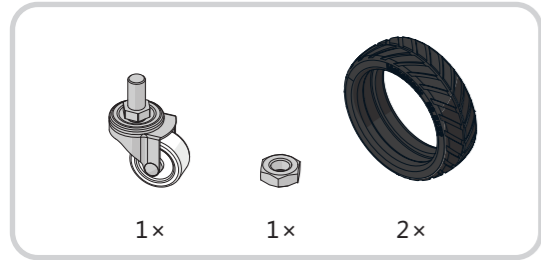

6

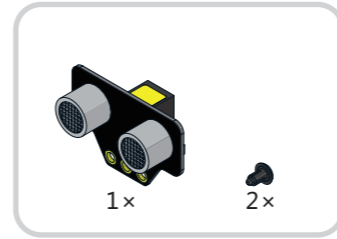
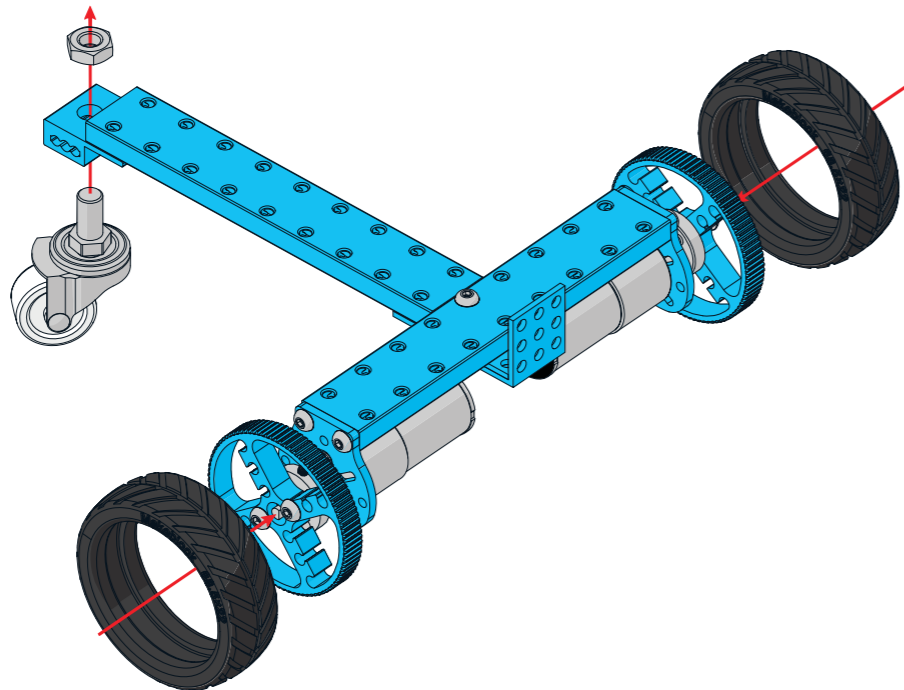

7

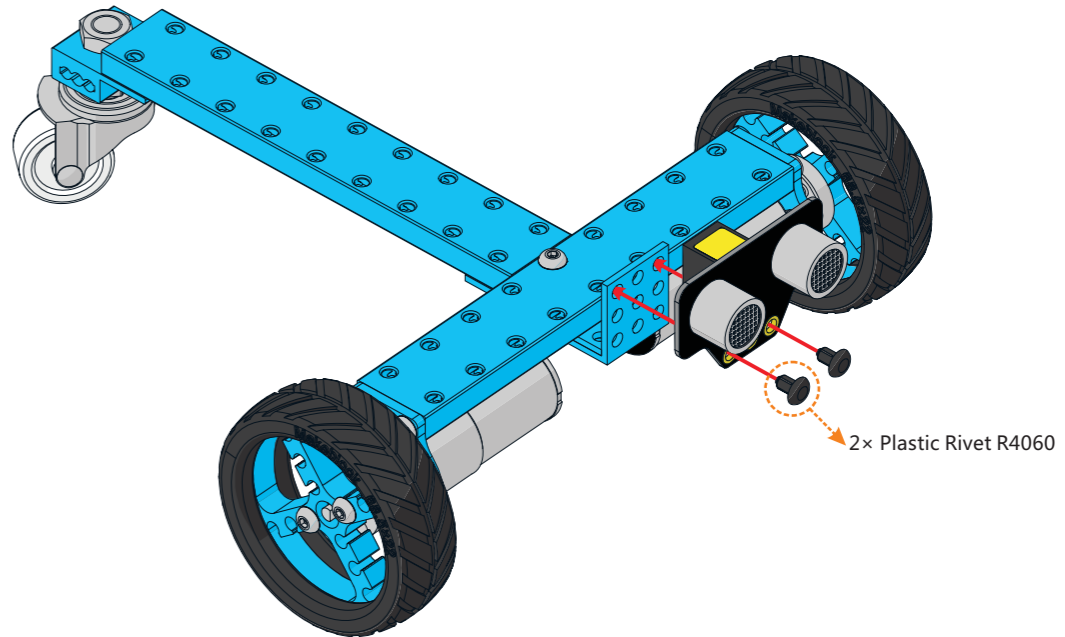

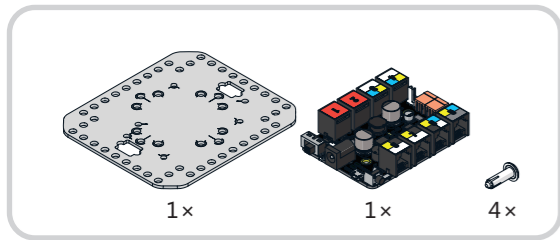

8

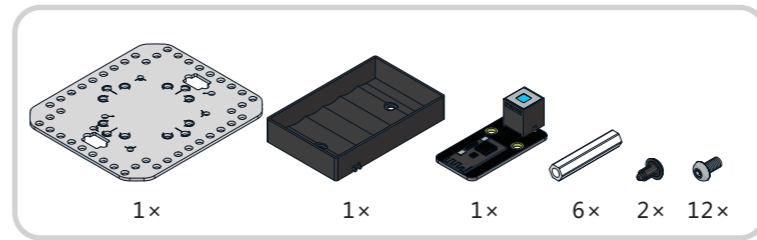
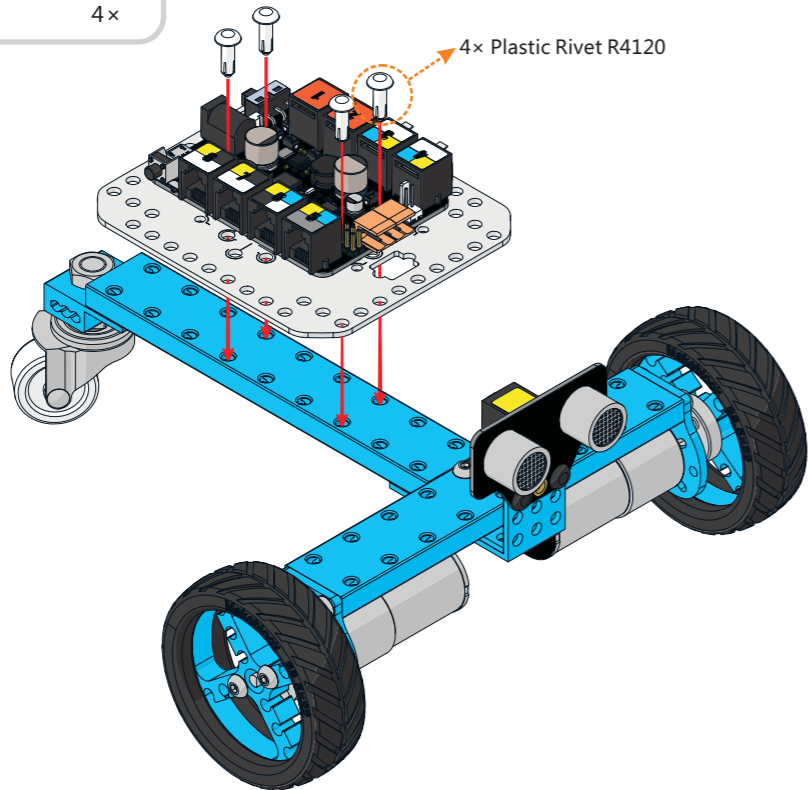

9

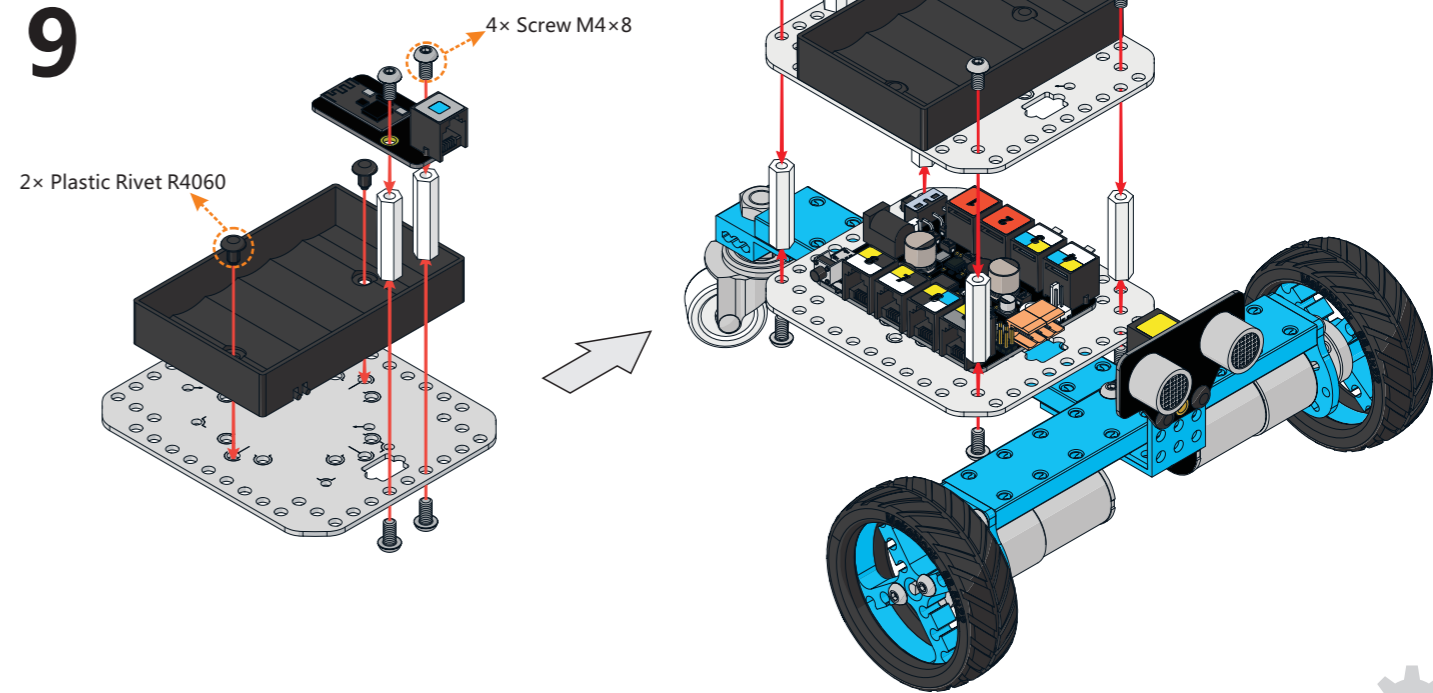

# Wiring and Programming

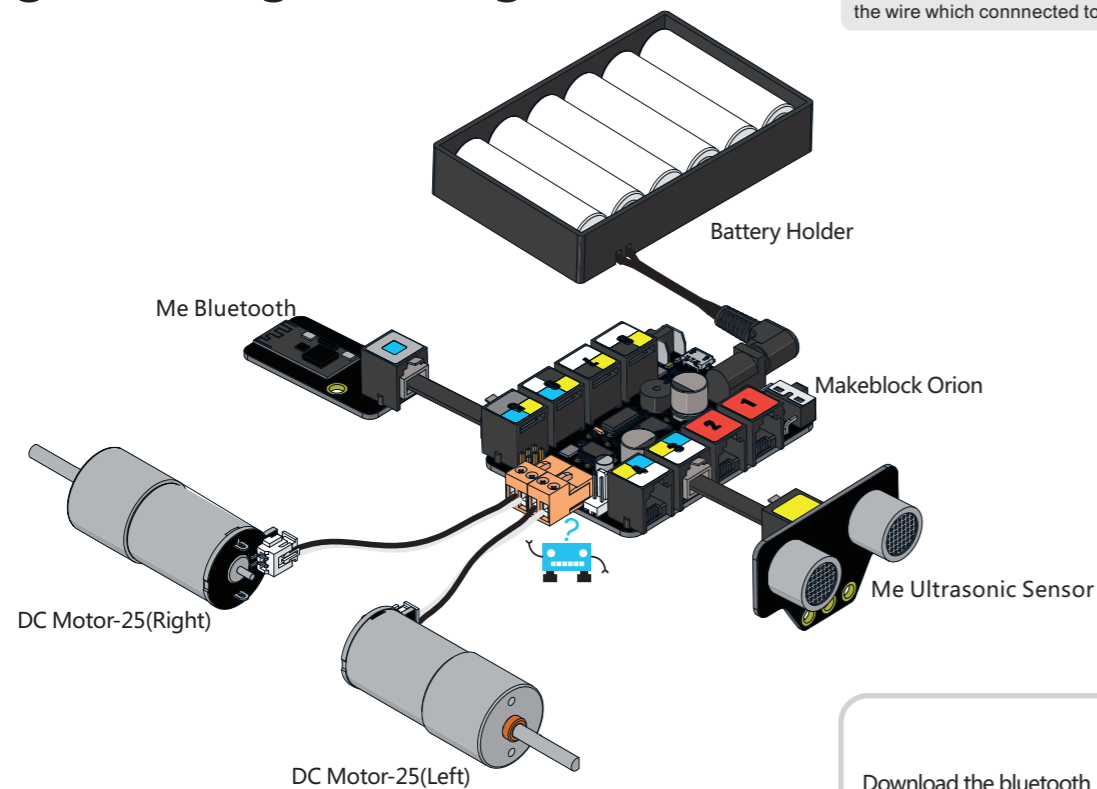

To reduce the electromagnetic interference, Please consider to add the magnetic ring to the wire which connected to motors.

Download the bluetooth control App by scanning the QR code



## You can build more on Makeblock

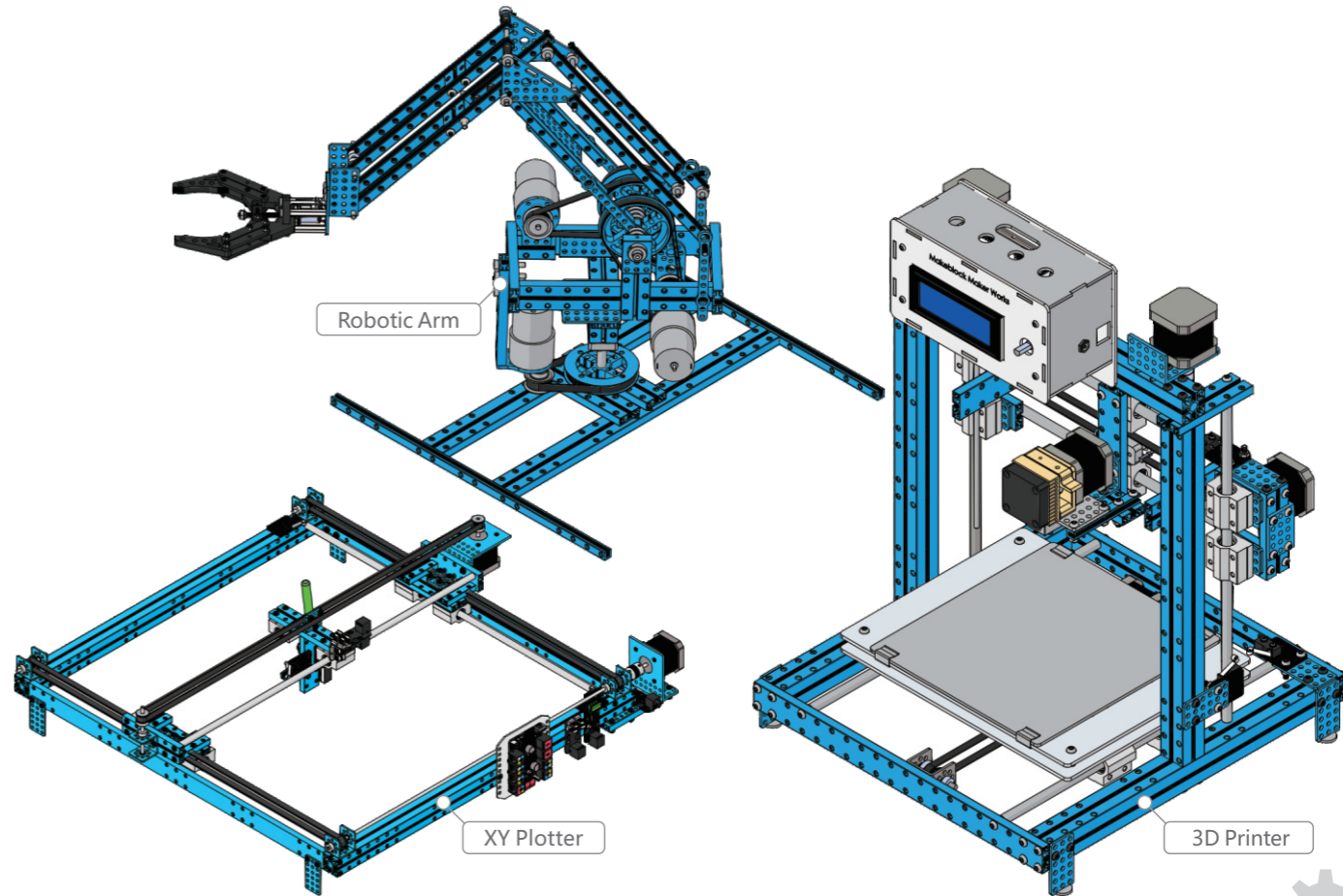

If you want to create advanced and customized programs, please refer to this part.

# Programming Guide

## Makeblock Orion Driver Installation

The USB interface of Makeblock Orion uses the chip CH340, you may need to install the chip CH340 drivers manually.

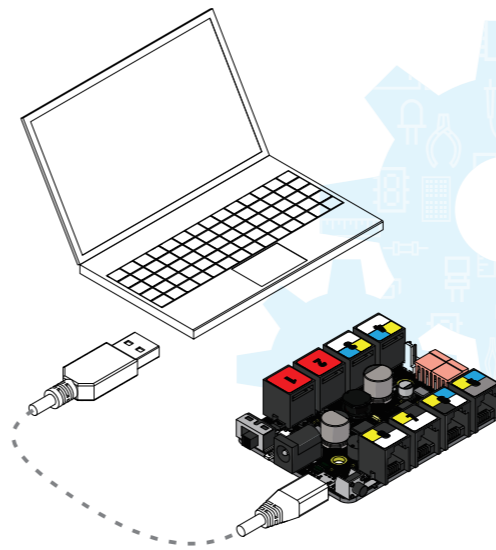

Visit the following URL for more details:  
[http://learn.makeblock.cc/driver\\_installation/](http://learn.makeblock.cc/driver_installation/)

## Working with Scratch

—Hack the Physical World

Makeblock platform supports graphical programming language Scratch, you can simply drag and joint the blocks to run your creations without difficult coding.

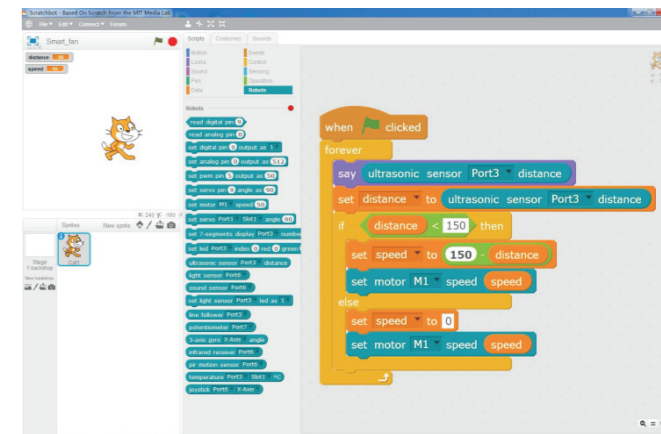

Visit the following URL for more details:  
<http://learn.makeblock.cc/learning-scratch>

Scratch is a programming language and online community where you can create your own interactive stories, games, and animations — and share your creations with others around the world. In the process of designing and programming Scratch projects, young people learn to think creatively, reason systematically, and work collaboratively. Scratch is a project of the Lifelong Kindergarten group at the MIT Media Lab. It is available for free at <http://scratch.mit.edu>



## Working with Arduino IDE

—Learn Programming the Fun Way



Learn and play at the same time!  
Enjoy it your own way.

Visit the following URL for more details:  
<http://learn.makeblock.cc/learning-Arduino>

Arduino is an open-source electronics prototyping platform based on flexible, easy-to-use hardware and software. The Arduino software consists of a development environment (IDE) and the core libraries. The IDE is written in Java and based on the Processing development environment. The core libraries are written in C and C++ and compiled using avr-gcc and AVR Libc.

## Working with the Makeblock App

—Construct It Once, Control It Everywhere

Install the Makeblock app to control your creations with your Android or iOS device.

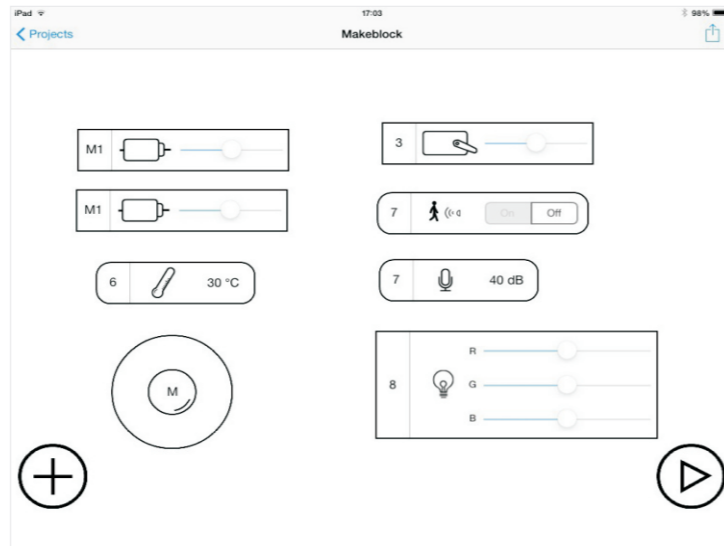

Visit the following URL for more details:  
<http://learn.makeblock.cc/learning-APP>

# Construct Your Dreams