

FEATURES

General

- Incorporates HDMI 1.4 features**
 - Audio return channel (ARC)
 - 3D video support
- 225 MHz supports 12-bit Deep Color operation in all video formats up to 1080p**
- Supports gamut metadata packet transmission**
- Integrated CEC buffer/controller—upgraded to HDMI 1.4**
- Compatible with DVI 1.0 and HDCP 1.4**
- Video/audio inputs accept logic levels from 1.8 V to 3.3 V**

Digital video

- 3D video ready
- Programmable two-way color space converter
- Supports RGB, YCbCr, and DDR
- Supports ITU656-based embedded syncs
- Automatic input video format timing detection (CEA-861-E)

Digital audio

- Audio return channel (ARC) for HDMI 1.4 support
- Supports standard S/PDIF for stereo LPCM or compressed audio up to 192 kHz
- 8-channel uncompressed LPCM I²S audio up to 192 kHz

Special features for easy system design

- On-chip MPU with I²C master to perform HDCP operations and EDID reading operations
- 5 V tolerant I²C and HPD I/Os, no extra device needed
- No audio master clock needed for supporting S/PDIF and I²S
- On-chip MPU reports HDMI events through interrupts and registers

APPLICATIONS

Home entertainment products

- Gaming consoles
- PCs
- DVD players and recorders
- Digital set top boxes
- A/V receivers

FUNCTIONAL BLOCK DIAGRAM

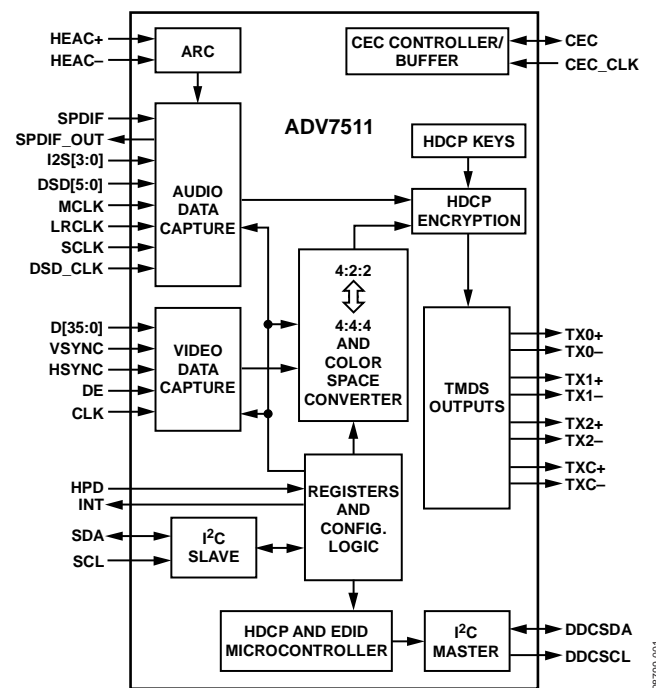

Figure 1.

GENERAL DESCRIPTION

The ADV7511 is a 225 MHz High-Definition Multimedia Interface (HDMI™) transmitter, which is ideal for home entertainment products including DVD players/recorders, digital set top boxes, A/V receivers, gaming consoles, and PCs.

The digital video interface contains an HDMI 1.4- and a DVI 1.0-compatible transmitter, and supports all HDTV formats (including 1080p with 12-bit Deep Color). The ADV7511 supports the HDMI 1.4-specific features, HEAC (ARC), and 3D video. In addition to these features, the ADV7511 supports x.v.Color™, high bit rate audio, and programmable AVI InfoFrames. With the inclusion of HDCP, the ADV7511 allows the secure transmission of protected content as specified by the HDCP 1.4 protocol.

The ADV7511 supports both S/PDIF and 8-channel I²S audio. Its high fidelity 8-channel I²S can transmit either stereo or 7.1 surround audio up to 768 kHz. The S/PDIF can carry compressed audio including Dolby® Digital, DTS®, and THX®. Fabricated in an advanced CMOS process, the ADV7511 is provided in a 100-lead LQFP surface-mount plastic package and is specified over the 0°C to +70°C temperature range.

For more information about the ADV7511, email: ATV_VideoTx_Apps@analog.com.

Rev. Sp0

Information furnished by Analog Devices is believed to be accurate and reliable. However, no responsibility is assumed by Analog Devices for its use, nor for any infringements of patents or other rights of third parties that may result from its use. Specifications subject to change without notice. No license is granted by implication or otherwise under any patent or patent rights of Analog Devices. Trademarks and registered trademarks are the property of their respective owners.

ADV7511* Product Page Quick Links

Last Content Update: 08/30/2016

Comparable Parts

View a parametric search of comparable parts

Evaluation Kits

- ADV7612 and ADV7511 Evaluation Board
- ADV7842 and ADV7511 Evaluation Board

Documentation

Application Notes

- AN-1143: ADV7511 HDCP 1.1 Enable/Disable Option
- AN-1180: Optimizing Video Platforms for Automated Post-Production Self-Tests
- AN-1270: ADV7511/ADV7511W/ADV7513 Based Video Generators

Data Sheet

- ADV7511: 225 MHz, High Performance HDMI Transmitter with ARC Data Sheet

User Guides

- UG-235: User Guide for Advantiv ADV7842/ADV7511 Video Evaluation Board

Software and Systems Requirements

- ADV7511 HDMI transmitter Linux Driver
- ADV7511 Xilinx KC705, VC707, ZC702 and ZED Reference Design
- FMC-IMAGEON Xilinx ML605 Reference Design

Tools and Simulations

- CEC Clock Timing Register Calculator (ADV7511-Family)
- ADV7511 IBIS Model

Reference Designs

- CN0224

Reference Materials

Technical Articles

- Enabling HDMI in the Automotive Segment

Design Resources

- ADV7511 Material Declaration
- PCN-PDN Information
- Quality And Reliability
- Symbols and Footprints

Discussions

View all ADV7511 EngineerZone Discussions

Sample and Buy

Visit the product page to see pricing options

Technical Support

Submit a technical question or find your regional support number

ADV7511

NOTES

I²C refers to a communications protocol originally developed by Philips Semiconductors (now NXP Semiconductors).

©2010 Analog Devices, Inc. All rights reserved. Trademarks and registered trademarks are the property of their respective owners.
D08799-0-2/10(Sp0)



www.analog.com