

FEATURES

- 128 positions
- 10 kΩ, 50 kΩ, 100 kΩ
- 20 V to 30 V single-supply operation
- ±10 V to ±15 V dual-supply operation
- 3-wire SPI®-compatible serial interface
- THD 0.006% typical
- Programmable preset
- Power shutdown: less than 1 μA
- iCMOS™ process technology

APPLICATIONS

- High voltage DAC
- Programmable power supply
- Programmable gain and offset adjustment
- Programmable filters, delays
- Actuator control
- Audio volume control
- Mechanical potentiometer replacement

GENERAL DESCRIPTION

The AD7376¹ is one of the few high voltage, high performance digital potentiometers² on the market. This device can be used as a programmable resistor or resistor divider. The AD7376 performs the same electronic adjustment function as mechanical potentiometers, variable resistors, and trimmers with enhanced resolution, solid-state reliability, and programmability. With digital rather than manual control, the AD7376 provides layout flexibility and allows closed-loop dynamic controllability.

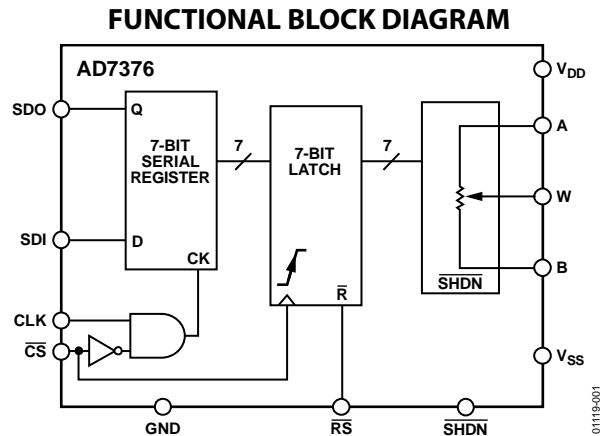

Figure 1.

The AD7376 features sleep-mode programmability in shutdown that can be used to program the preset before device activation, thus providing an alternative to costly EEPROM solutions.

The AD7376 is available in 14-lead TSSOP and 16-lead wide body SOIC packages in 10 kΩ, 50 kΩ, and 100 kΩ options. All parts are guaranteed to operate over the -40°C to +85°C extended industrial temperature range.

¹ Patent number: 54952455.

² The terms *digital potentiometer* and *RDAC* are used interchangeably.

Rev. D

Information furnished by Analog Devices is believed to be accurate and reliable. However, no responsibility is assumed by Analog Devices for its use, nor for any infringements of patents or other rights of third parties that may result from its use. Specifications subject to change without notice. No license is granted by implication or otherwise under any patent or patent rights of Analog Devices. Trademarks and registered trademarks are the property of their respective owners.

AD7376* Product Page Quick Links

Last Content Update: 08/30/2016

[Comparable Parts](#)

View a parametric search of comparable parts

[Evaluation Kits](#)

- [AD7376 Evaluation Board](#)

[Documentation](#)

Application Notes

- [AN-1291: Digital Potentiometers: Frequently Asked Questions](#)
- [AN-580: Programmable Oscillator Uses Digital Potentiometers](#)
- [AN-582: Resolution Enhancements of Digital Potentiometers with Multiple Devices](#)
- [AN-686: Implementing an I2C® Reset](#)

Data Sheet

- [AD7376: +30 V/±15 V Operation 128-Position Digital Potentiometer Data Sheet](#)

[Software and Systems Requirements](#)

- [Digital Potentiometer Linux Driver](#)
- [AD7376 Evaluation Software](#)

[Design Resources](#)

- [AD7376 Material Declaration](#)
- [PCN-PDN Information](#)
- [Quality And Reliability](#)
- [Symbols and Footprints](#)

[Discussions](#)

View all [AD7376 EngineerZone Discussions](#)

[Sample and Buy](#)

Visit the product page to see pricing options

[Technical Support](#)

Submit a technical question or find your regional support number

* This page was dynamically generated by Analog Devices, Inc. and inserted into this data sheet. Note: Dynamic changes to the content on this page does not constitute a change to the revision number of the product data sheet. This content may be frequently modified.

TABLE OF CONTENTS

Features	1
Applications.....	1
Functional Block Diagram	1
General Description	1
Revision History	2
Specifications.....	3
Electrical Characteristics—10 k Ω Version.....	3
Electrical Characteristics—50 k Ω , 100 k Ω Versions	4
Timing Specifications	5
3-Wire Digital Interface.....	6
Absolute Maximum Ratings.....	7
ESD Caution.....	7
Pin Configurations and Function Descriptions	8
Typical Performance Characteristics	9
Theory of Operation	12

REVISION HISTORY

8/11—Rev. C to Rev. D

Changes to Output Logic Low Conditions, Table 1	3
Changes to Output Logic Low Conditions, Table 2.....	5
Changes to Figure 28.....	14
Updates Outline Dimensions.....	18

7/09—Rev. B to Rev. C

Changes to Features Section.....	1
Updates Outline Dimensions.....	19
Changes to Ordering Guide	20

3/07—Rev. A to Rev. B

Updated Format.....	Universal
Changes to Absolute Maximum Ratings	7
Changes to ESD Protection Section	14
Changes to Ordering Guide	19

Programming the Variable Resistor.....	12
Programming the Potentiometer Divider.....	13
3-Wire Serial Bus Digital Interface	13
Daisy-Chain Operation	14
ESD Protection	14
Terminal Voltage Operating Range	14
Power-Up and Power-Down Sequences.....	14
Layout and Power Supply Biasing.....	15
Applications Information	16
High Voltage DAC.....	16
Programmable Power Supply	16
Audio Volume Control.....	17
Outline Dimensions	18
Ordering Guide	19

11/05—Rev. 0 to Rev. A

Updated Format.....	Universal
Deleted DIP Package.....	Universal
Changes to Features	1
Separated Electrical Characteristics into Table 1 and Table 2.....	3
Separated Interface Timing into Table 3	5
Changes to Table 1 Through Table 3.....	3
Added Table 4	6
Added Figure 2.....	6
Changes to Absolute Maximum Ratings Section.....	7
Deleted Parametric Test Circuits Section.....	7
Changes to Typical Performance Characteristics.....	9
Added Daisy-Chain Operation Section	14
Added ESD Protection Section.....	14
Added Terminal Voltage Operating Range Section.....	14
Added Power-Up and Power-Down Sequences Section	14
Added Layout and Power Supply Biasing Section	15
Added Applications Section.....	16
Updated Outline Dimensions.....	18
Changes to Ordering Guide	19

10/97—Revision 0: Initial Version

SPECIFICATIONS

ELECTRICAL CHARACTERISTICS—10 kΩ VERSION

$V_{DD}/V_{SS} = \pm 15\text{ V} \pm 10\%$, $V_A = V_{DD}$, $V_B = V_{SS}/0\text{ V}$, $-40^\circ\text{C} < T_A < +85^\circ\text{C}$, unless otherwise noted.

Table 1.

Parameter	Symbol	Conditions	Min	Typ ¹	Max	Unit
DC CHARACTERISTICS— RHEOSTAT MODE						
Resistor Differential Nonlinearity ²	R-DNL	R_{WB} , $V_A = \text{NC}$, $V_{DD}/V_{SS} = \pm 15\text{ V}$	-1	±0.5	+1	LSB
Resistor Nonlinearity ²	R-INL	R_{WB} , $V_A = \text{NC}$, $V_{DD}/V_{SS} = \pm 15\text{ V}$	-1	±0.5	+1	LSB
Nominal Resistor Tolerance	ΔR_{AB}	$T_A = 25^\circ\text{C}$	-30		+30	%
Resistance Temperature Coefficient ³	$(\Delta R_{AB}/R_{AB})/\Delta T \times 10^6$	$V_{AB} = V_{DD}$, wiper = no connect		-300		ppm/°C
Wiper Resistance	R_w	$V_{DD}/V_{SS} = \pm 15\text{ V}$ $V_{DD}/V_{SS} = \pm 5\text{ V}$		120 260	200	Ω Ω
DC CHARACTERISTICS— POTENTIOMETER DIVIDER MODE						
Integral Nonlinearity ⁴	INL	$V_{DD}/V_{SS} = \pm 15\text{ V}$	-1	±0.5	+1	LSB
Differential Nonlinearity ⁴	DNL	$V_{DD}/V_{SS} = \pm 15\text{ V}$	-1	±0.5	+1	LSB
Voltage Divider Temperature Coefficient	$(\Delta V_w/V_w)/\Delta T \times 10^6$	Code = 0x40		5		ppm/°C
Full-Scale Error	V_{WFSE}	Code = 0x7F, $V_{DD}/V_{SS} = \pm 15\text{ V}$	-3	-1.5	0	LSB
Zero-Scale Error	V_{WZSE}	Code = 0x00, $V_{DD}/V_{SS} = \pm 15\text{ V}$	0	1.5	3	LSB
RESISTOR TERMINALS						
Voltage Range ⁵	$V_{A,B,W}$		V_{SS}		V_{DD}	V
Capacitance ⁶ A, B	$C_{A,B}$	$f = 1\text{ MHz}$, measured to GND, code = 0x40		45		pF
Capacitance ⁶	C_w	$f = 1\text{ MHz}$, measured to GND, code = 0x40		60		pF
Shutdown Supply Current ⁷	$I_{A,SD}$	$V_A = V_{DD}$, $V_B = 0\text{ V}$, $\overline{\text{SHDN}} = 0$		0.02	1	μA
Shutdown Wiper Resistance	$R_{w,SD}$	$V_A = V_{DD}$, $V_B = 0\text{ V}$, $\overline{\text{SHDN}} = 0$, $V_{DD} = 15\text{ V}$		170	400	Ω
Common-Mode Leakage	I_{CM}	$V_A = V_B = V_w$		1		nA
DIGITAL INPUTS AND OUTPUTS						
Input Logic High	V_{IH}	$V_{DD} = 5\text{ V}$ or 15 V	2.4			V
Input Logic Low	V_{IL}	$V_{DD} = 5\text{ V}$ or 15 V			0.8	V
Output Logic High	V_{OH}	$R_{\text{pull-up}} = 2.2\text{ k}\Omega$ to 5 V	4.9			V
Output Logic Low	V_{OL}	$I_{OL} = 1.6\text{ mA}$, $V_{DD} = 15\text{ V}$			0.4	V
Input Current	I_{IL}	$V_{IN} = 0\text{ V}$ or 5 V			±1	μA
Input Capacitance ⁶	C_{IL}			5		pF
POWER SUPPLIES						
Power Supply Range	V_{DD}/V_{SS}	Dual-supply range	±4.5		±16.5	V
Power Supply Range	V_{DD}	Single-supply range, $V_{SS} = 0$	4.5		33	V
Positive Supply Current	I_{DD}	$V_{IH} = 5\text{ V}$ or $V_{IL} = 0\text{ V}$, $V_{DD}/V_{SS} = \pm 15\text{ V}$			2	mA
		$V_{IH} = 5\text{ V}$ or $V_{IL} = 0\text{ V}$, $V_{DD}/V_{SS} = \pm 5\text{ V}$		12	25	μA
Negative Supply Current	I_{SS}	$V_{IH} = 5\text{ V}$ or $V_{IL} = 0\text{ V}$, $V_{DD}/V_{SS} = \pm 15\text{ V}$			-0.1	mA
		$V_{IH} = 5\text{ V}$ or $V_{IL} = 0\text{ V}$, $V_{DD}/V_{SS} = \pm 5\text{ V}$			-0.1	mA
Power Dissipation ⁸	P_{DISS}	$V_{IH} = 5\text{ V}$ or $V_{IL} = 0\text{ V}$, $V_{DD}/V_{SS} = \pm 15\text{ V}$			31.5	mW
Power Supply Rejection Ratio	PSRR	$\Delta V_{DD}/\Delta V_{SS} = \pm 15\text{ V} \pm 10\%$	-0.2	±0.05	+0.2	%/%

AD7376

Parameter	Symbol	Conditions	Min	Typ ¹	Max	Unit
DYNAMIC CHARACTERISTICS ^{6, 9, 10}						
Bandwidth –3 dB	BW	Code = 0x40		470		kHz
Total Harmonic Distortion	THD _W	V _A = 1 V rms, V _B = 0 V, f = 1 kHz		0.006		%
V _W Settling Time	t _s	V _A = 10 V, V _B = 0 V, ±1 LSB error band		4		μs
Resistor Noise Voltage	e _{N_WB}	R _{WB} = 5 kΩ, f = 1 kHz		0.9		nV/√Hz

¹ Typical values represent average readings at 25°C, V_{DD} = 15 V, and V_{SS} = –15 V.

² Resistor position nonlinearity error R-INL is the deviation from an ideal value measured between the maximum and minimum resistance wiper positions. R-DNL measures the relative step change from an ideal value measured between successive tap positions. Parts are guaranteed monotonic.

³ Pb-free parts have a 35 ppm/°C temperature coefficient (tempco).

⁴ INL and DNL are measured at V_W with the RDAC configured as a potentiometer divider, similar to a voltage output digital-to-analog converter. V_A = V_{DD} and V_B = 0 V. DNL specification limits of ±1 LSB maximum are guaranteed monotonic operating conditions.

⁵ Resistor Terminals A, B, and W have no limitations on polarity with respect to each other.

⁶ Guaranteed by design and not subject to production test.

⁷ Measured at the A terminal. A terminal is open circuit in shutdown mode.

⁸ P_{DISS} is calculated from (I_{DD} × V_{DD}) + abs(I_{SS} × V_{SS}). CMOS logic level inputs result in minimum power dissipation.

⁹ Bandwidth, noise, and settling times are dependent on the terminal resistance value chosen. The lowest R value results in the fastest settling time and highest bandwidth. The highest R value results in the minimum overall power consumption.

¹⁰ All dynamic characteristics use V_{DD} = 15 V and V_{SS} = –15 V.

ELECTRICAL CHARACTERISTICS—50 kΩ, 100 kΩ VERSIONS

V_{DD}/V_{SS} = ±15 V ± 10% or ±5 V ± 10%, V_A = V_{DD}, V_B = V_{SS}/0 V, –40°C < T_A < +85°C, unless otherwise noted.

Table 2.

Parameter	Symbol	Conditions	Min	Typ ¹	Max	Unit
DC CHARACTERISTICS—RHEOSTAT MODE						
Resistor Differential Nonlinearity ²	R-DNL	R _{WB} , V _A = NC	–1	±0.5	+1	LSB
Resistor Nonlinearity ²	R-INL	R _{WB} , V _A = NC, R _{AB} = 50 kΩ	–1.5	±0.5	+1.5	LSB
		R _{WB} , V _A = NC, R _{AB} = 100 kΩ	–1	±0.5	+1	LSB
Nominal Resistor Tolerance	ΔR _{AB}	T _A = 25°C	–30		+30	%
Resistance Temperature Coefficient ³	(ΔR _{AB} /R _{AB})/ΔT × 10 ⁶	V _{AB} = V _{DD} , wiper = no connect		–300		ppm/°C
Wiper Resistance	R _W	V _{DD} /V _{SS} = ±15 V		120	200	Ω
		V _{DD} /V _{SS} = ±5 V		260		Ω
DC CHARACTERISTICS— POTENTIOMETER DIVIDER MODE						
Integral Nonlinearity ⁴	INL		–1	±0.5	+1	LSB
Differential Nonlinearity ⁴	DNL		–1	±0.5	+1	LSB
Voltage Divider Temperature Coefficient	(ΔV _W /V _W)/ΔT × 10 ⁶	Code = 0x40		5		ppm/°C
Full-Scale Error	V _{WFSE}	Code = 0x7F	–2	–0.5	0	LSB
Zero-Scale Error	V _{WZSE}	Code = 0x00	0	0.5	1	LSB
RESISTOR TERMINALS						
Voltage Range ⁵	V _{A, B, W}		V _{SS}		V _{DD}	V
Capacitance ⁶ A, B	C _{A, B}	f = 1 MHz, measured to GND, code = 0x40		45		pF
Capacitance ⁶	C _W	f = 1 MHz, measured to GND, code = 0x40		60		pF
Shutdown Supply Current ⁷	I _{A_SD}	V _A = V _{DD} , V _B = 0 V, $\overline{\text{SHDN}} = 0$		0.02	1	μA
Shutdown Wiper Resistance	R _{W_SD}	V _A = V _{DD} , V _B = 0 V, $\overline{\text{SHDN}} = 0$, V _{DD} = 15 V		170	400	Ω
Common-Mode Leakage	I _{CM}	V _A = V _B = V _W		1		nA

Parameter	Symbol	Conditions	Min	Typ ¹	Max	Unit
DIGITAL INPUTS AND OUTPUTS						
Input Logic High	V _{IH}	V _{DD} = 5 V or 15 V	2.4			V
Input Logic Low	V _{IL}	V _{DD} = 5 V or 15 V			0.8	V
Output Logic High	V _{OH}	R _{Pull-Up} = 2.2 kΩ to 5 V	4.9			V
Output Logic Low	V _{OL}	I _{OL} = 1.6 mA, V _{DD} = 15 V			0.4	V
Input Current	I _{IL}	V _{IN} = 0 V or 5 V			±1	μA
Input Capacitance ⁶	C _{IL}			5		pF
POWER SUPPLIES						
Power Supply Range	V _{DD} /V _{SS}	Dual-supply range	±4.5		±16.5	V
Power Supply Range	V _{DD}	Single-supply range, V _{SS} = 0	4.5		33	V
Positive Supply Current	I _{DD}	V _{IH} = 5 V or V _{IL} = 0 V, V _{DD} /V _{SS} = ±15 V			2	mA
		V _{IH} = 5 V or V _{IL} = 0 V, V _{DD} /V _{SS} = ±5 V		12	25	μA
Negative Supply Current	I _{SS}	V _{IH} = 5 V or V _{IL} = 0 V, V _{DD} /V _{SS} = ±15 V			-0.1	mA
		V _{IH} = 5 V or V _{IL} = 0 V, V _{DD} /V _{SS} = ±5 V			-0.1	mA
Power Dissipation ⁸	P _{DISS}	V _{IH} = 5 V or V _{IL} = 0 V, V _{DD} /V _{SS} = ±15 V			31.5	mW
Power Supply Rejection Ratio	PSRR		-0.25	±0.1	+0.25	%/%
DYNAMIC CHARACTERISTICS^{6, 9, 10}						
Bandwidth -3 dB	BW	R _{AB} = 50 kΩ, code = 0x40		90		kHz
		R _{AB} = 100 kΩ, code = 0x40		50		kHz
Total Harmonic Distortion	THD _w	V _A = 1 V rms, V _B = 0 V, f = 1 kHz		0.002		%
V _w Settling Time	t _s	V _A = 10 V, V _B = 0 V, ±1 LSB error band		4		μs
Resistor Noise Voltage	e _{N_WB}	R _{WB} = 25 kΩ, f = 1 kHz		2		nV/√Hz

¹ Typical values represent average readings at 25°C, V_{DD} = 15 V, and V_{SS} = -15 V.

² Resistor position nonlinearity error R-INL is the deviation from an ideal value measured between the maximum and minimum resistance wiper positions. R-DNL measures the relative step change from an ideal value measured between successive tap positions. Parts are guaranteed monotonic.

³ Pb-free parts have a 35 ppm/°C temperature coefficient.

⁴ INL and DNL are measured at V_w with the RDAC configured as a potentiometer divider, similar to a voltage output digital-to-analog converter. V_A = V_{DD} and V_B = 0 V. DNL specification limits of ±1 LSB maximum are guaranteed monotonic operating conditions.

⁵ Resistor Terminals A, B, and W have no limitations on polarity with respect to each other.

⁶ Guaranteed by design and not subject to production test.

⁷ Measured at the A terminal. A terminal is open circuit in shutdown mode.

⁸ P_{DISS} is calculated from (I_{DD} × V_{DD}) + abs(I_{SS} × V_{SS}). CMOS logic level inputs result in minimum power dissipation.

⁹ Bandwidth, noise, and settling times are dependent on the terminal resistance value chosen. The lowest R value results in the fastest settling time and highest bandwidth. The highest R value results in the minimum overall power consumption.

¹⁰ All dynamic characteristics use V_{DD} = 15 V and V_{SS} = -15 V.

TIMING SPECIFICATIONS

Table 3.

Parameter	Symbol	Conditions	Min	Typ	Max	Unit
INTERFACE TIMING CHARACTERISTICS^{1, 2}						
Clock Frequency	f _{CLK}				4	MHz
Input Clock Pulse Width	t _{CH} , t _{CL}	Clock level high or low	120			ns
Data Setup Time	t _{DS}		30			ns
Data Hold Time	t _{DH}		20			ns
CLK to SDO Propagation Delay ³	t _{PD}	R _{Pull-Up} = 2.2 kΩ, C _L < 20 pF	10		100	ns
$\overline{\text{CS}}$ Setup Time	t _{CSS}		120			ns
$\overline{\text{CS}}$ High Pulse Width	t _{CSW}		150			ns
Reset Pulse Width	t _{RS}		120			ns
CLK Fall to $\overline{\text{CS}}$ Fall Hold Time	t _{CSh0}		10			ns
CLK Rise to $\overline{\text{CS}}$ Rise Hold Time	t _{CSh}		120			ns
$\overline{\text{CS}}$ Rise to Clock Rise Setup	t _{Cs1}		120			ns

¹ Guaranteed by design and not subject to production test.

² See Figure 3 for the location of the measured values. All input control voltages are specified with t_r = t_f = 1 ns (10% to 90% of V_{DD}) and timed from a voltage level of 1.6 V. Switching characteristics are measured using V_{DD} = 15 V and V_{SS} = -15 V.

³ Propagation delay depends on value of V_{DD}, R_{Pull-Up}, and C_L.

3-WIRE DIGITAL INTERFACE

Table 4. AD7376 Serial Data-Word Format¹

MSB						LSB
D6	D5	D4	D3	D2	D1	D0
2 ⁶						2 ⁰

¹ Data is loaded MSB first.

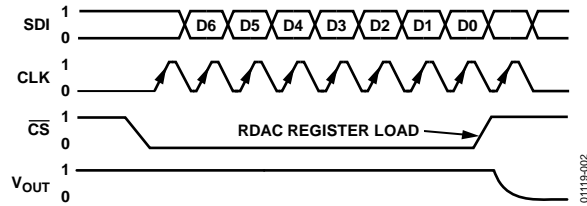

Figure 2. AD7376 3-Wire Digital Interface Timing Diagram
($V_A = V_{DD}$, $V_B = 0\text{ V}$, $V_W = V_{OUT}$)

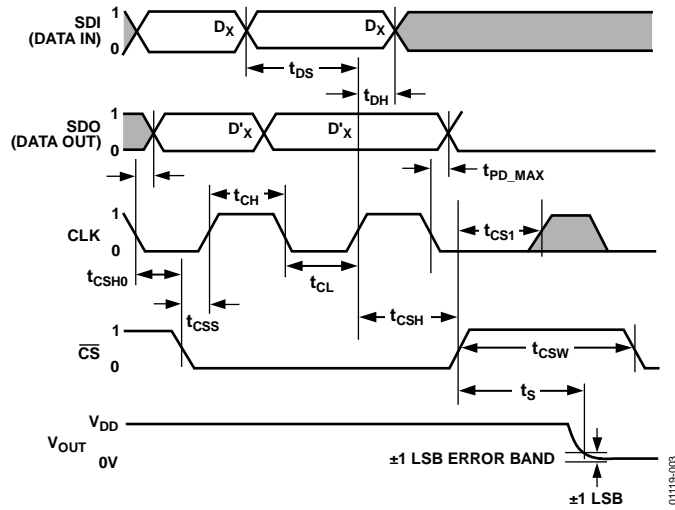

Figure 3. Detail Timing Diagram

ABSOLUTE MAXIMUM RATINGS

$T_A = 25^\circ\text{C}$, unless otherwise noted.

Table 5.

Parameter	Rating
V_{DD} to GND	-0.3 V to +35 V
V_{SS} to GND	+0.3 V to -16.5 V
V_{DD} to V_{SS}	-0.3 V to +35 V
V_A, V_B, V_W to GND	V_{SS} to V_{DD}
Maximum Current	
I_{WB}, I_{WA} Pulsed	± 20 mA
I_{WB} Continuous ($R_{WB} \leq 6$ k Ω , A open, $V_{DD}/V_{SS} = 30$ V/0 V) ¹	± 5 mA
I_{WA} Continuous ($R_{WA} \leq 6$ k Ω , B open, $V_{DD}/V_{SS} = 30$ V/0 V) ¹	± 5 mA
Digital Input and Output Voltages to GND	0 V to $V_{DD} + 0.3$ V
Operating Temperature Range	-40°C to +85°C
Maximum Junction Temperature (T_{JMAX}) ²	150°C
Storage Temperature Range	-65°C to +150°C
Reflow Soldering	
Peak Temperature	260°C
Time at Peak Temperature	20 sec to 40 sec
Package Power Dissipation	$(T_{JMAX} - T_A)/\theta_{JA}$
Thermal Resistance θ_{JA}	
16-Lead SOIC_W	120°C/W
14-Lead TSSOP	240°C/W

¹ Maximum terminal current is bound by the maximum current handling of the switches, maximum power dissipation of the package, and maximum applied voltage across any two of the A, B, and W terminals at a given resistance.

² Package power dissipation = $(T_{JMAX} - T_A)/\theta_{JA}$.

Stresses above those listed under Absolute Maximum Ratings may cause permanent damage to the device. This is a stress rating only; functional operation of the device at these or any other conditions above those indicated in the operational section of this specification is not implied. Exposure to absolute maximum rating conditions for extended periods may affect device reliability.

ESD CAUTION



ESD (electrostatic discharge) sensitive device. Charged devices and circuit boards can discharge without detection. Although this product features patented or proprietary protection circuitry, damage may occur on devices subjected to high energy ESD. Therefore, proper ESD precautions should be taken to avoid performance degradation or loss of functionality.

PIN CONFIGURATIONS AND FUNCTION DESCRIPTIONS

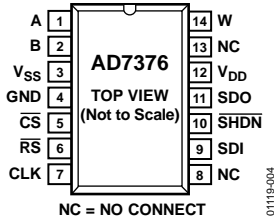

Figure 4. 14-Lead TSSOP Pin Configuration

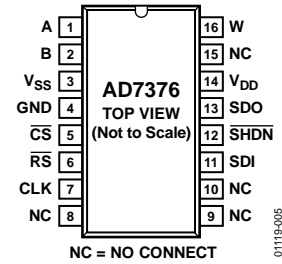

Figure 5. 16-Lead SOIC_W Pin Configuration

Table 6. Pin Function Descriptions

Pin No.		Mnemonic	Description
14-Lead TSSOP	16-Lead SOL		
1	1	A	A Terminal. $V_{SS} \leq V_A \leq V_{DD}$.
2	2	B	B Terminal. $V_{SS} \leq V_B \leq V_{DD}$.
3	3	V_{SS}	Negative Power Supply.
4	4	GND	Digital Ground.
5	5	\overline{CS}	Chip Select Input, Active Low. When \overline{CS} returns high, data is loaded into the wiper register.
6	6	\overline{RS}	Reset to Midscale.
7	7	CLK	Serial Clock Input. Positive edge triggered.
8	8, 9, 10	NC	No Connect. Let it float or ground.
9	11	SDI	Serial Data Input (data loads MSB first).
10	12	\overline{SHDN}	Shutdown. A terminal open ended; W and B terminals shorted. Can be used as programmable preset. ¹
11	13	SDO	Serial Data Output.
12	14	V_{DD}	Positive Power Supply.
13	15	NC	No Connect. Let it float or ground.
14	16	W	Wiper Terminal. $V_{SS} \leq V_W \leq V_{DD}$.

¹ Assert shutdown and program the device during power-up. Then, deassert the shutdown to achieve the desirable preset level.

TYPICAL PERFORMANCE CHARACTERISTICS

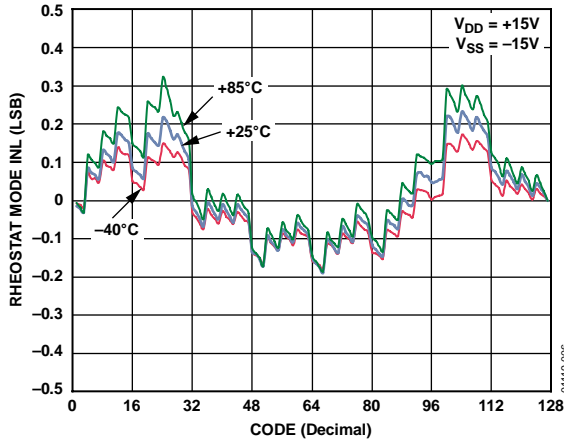

Figure 6. Resistance Step Position Nonlinearity Error vs. Code

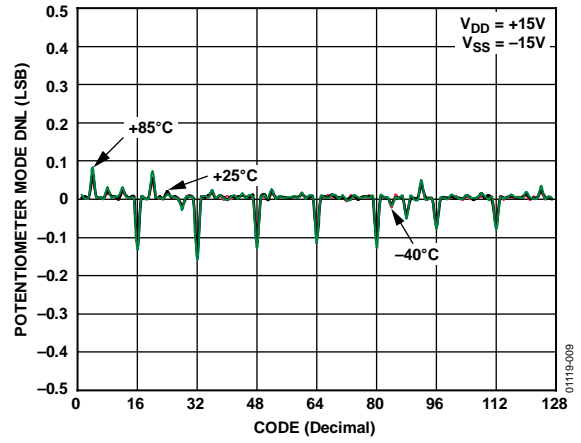

Figure 9. Potentiometer Divider Differential Nonlinearity Error vs. Code

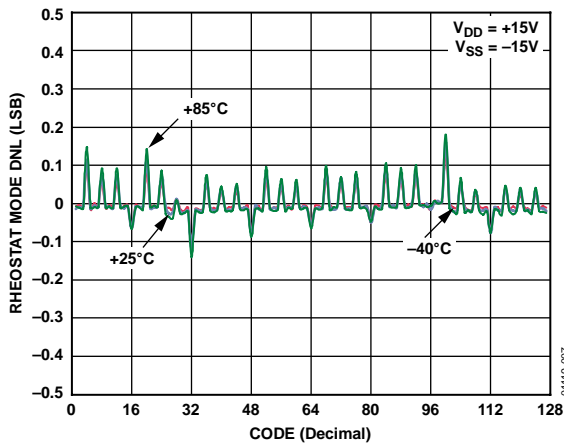

Figure 7. Relative Resistance Step Change from Ideal vs. Code

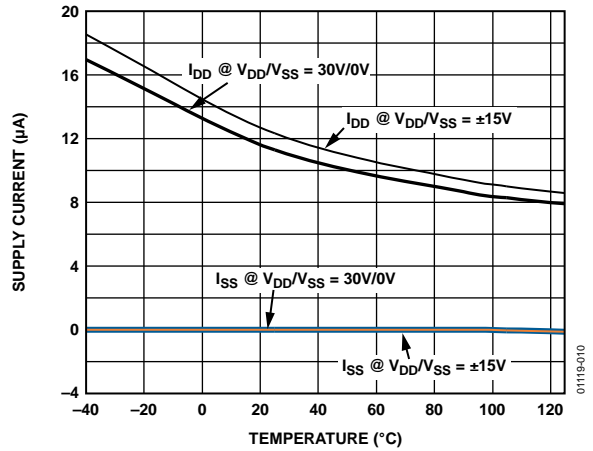

Figure 10. Supply Current (I_{DD} , I_{SS}) vs. Temperature

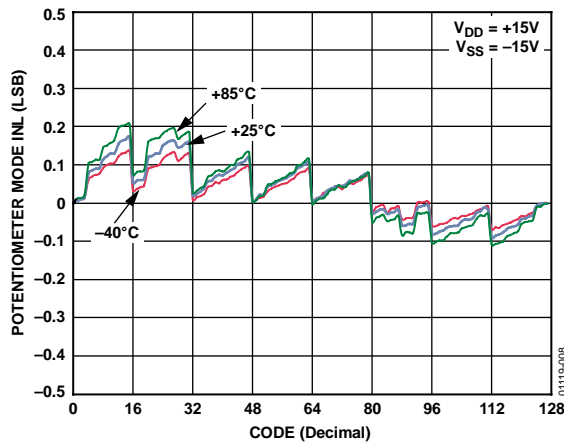

Figure 8. Potentiometer Divider Nonlinearity Error vs. Code

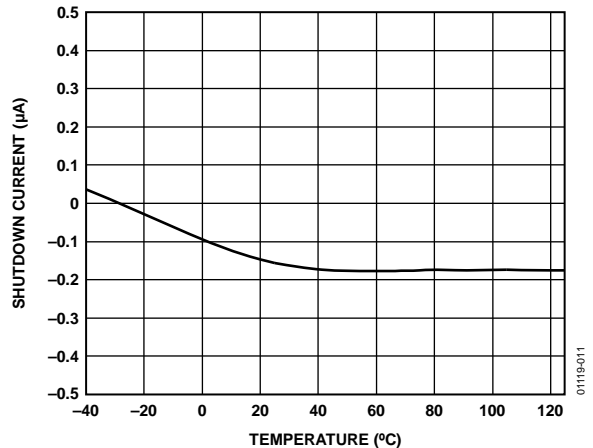

Figure 11. Shutdown Current vs. Temperature

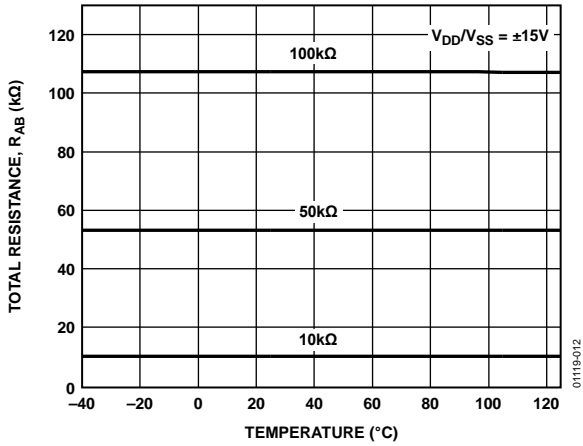

Figure 12. Total Resistance vs. Temperature

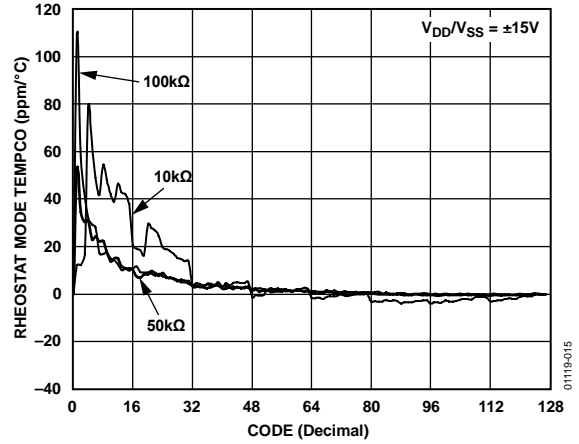

Figure 15. $(\Delta V_{WB}/V_{WB})/\Delta T$ Potentiometer Mode Tempco

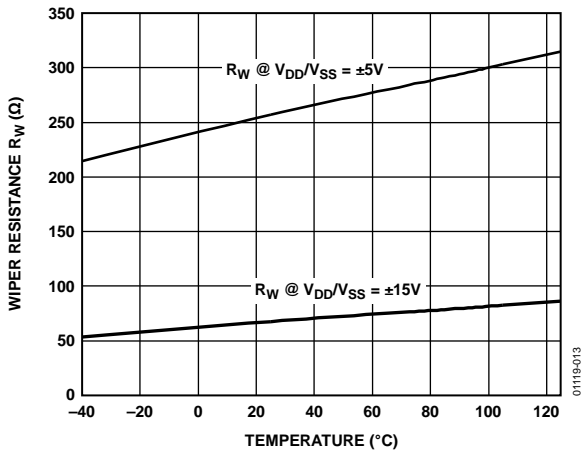

Figure 13. Wiper Contact Resistance vs. Temperature

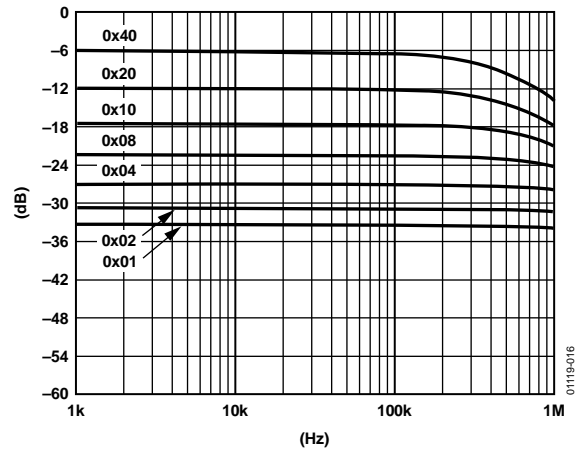

Figure 16. 10 kΩ Gain vs. Frequency vs. Code

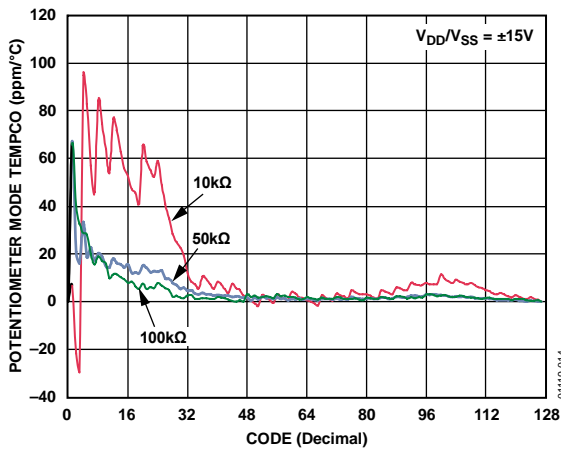

Figure 14. $(\Delta R_{WB}/R_{WB})/\Delta T$ Rheostat Mode Tempco

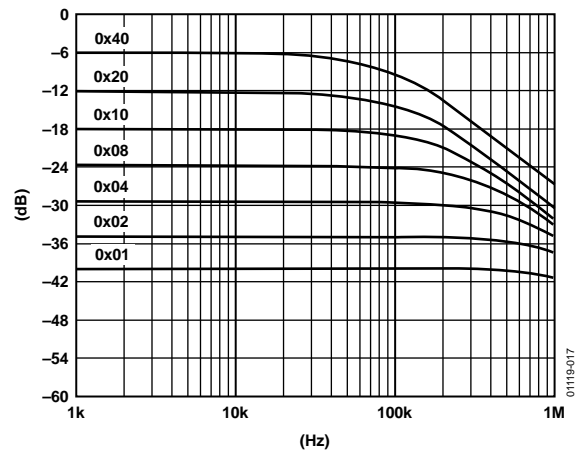

Figure 17. 50 kΩ Gain vs. Frequency vs. Code

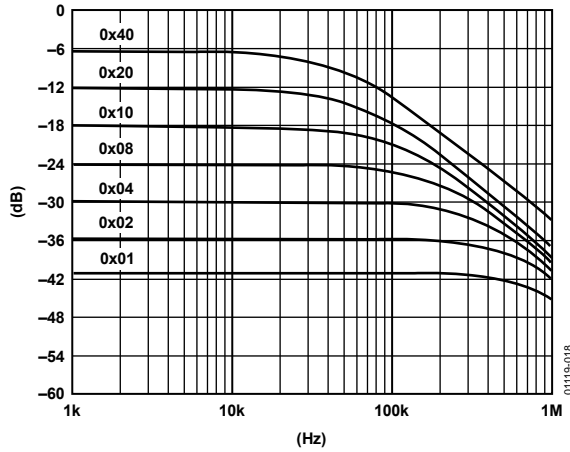

Figure 18. 100 kΩ Gain vs. Frequency vs. Code

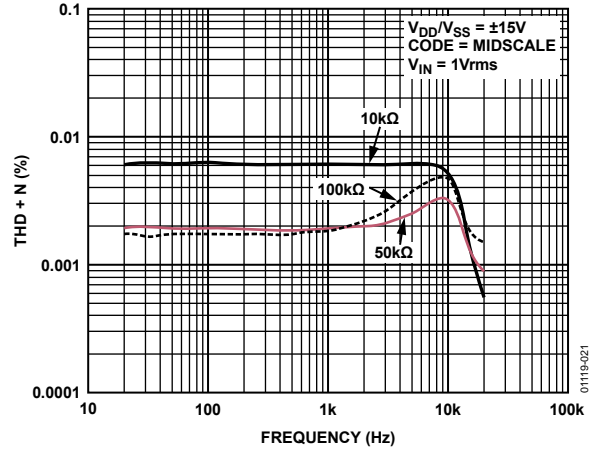

Figure 21. Total Harmonic Distortion Plus Noise vs. Frequency

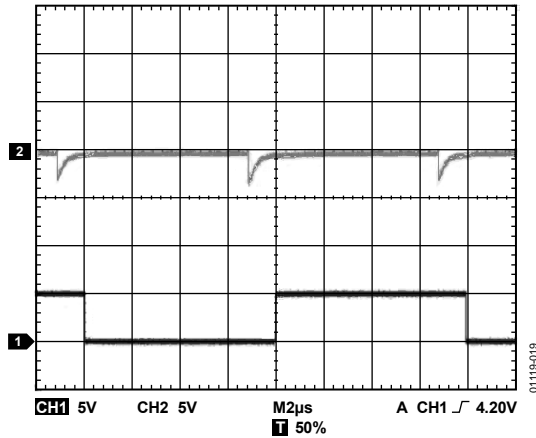

Figure 19. Midscale to Midscale - 1 Transition Glitch

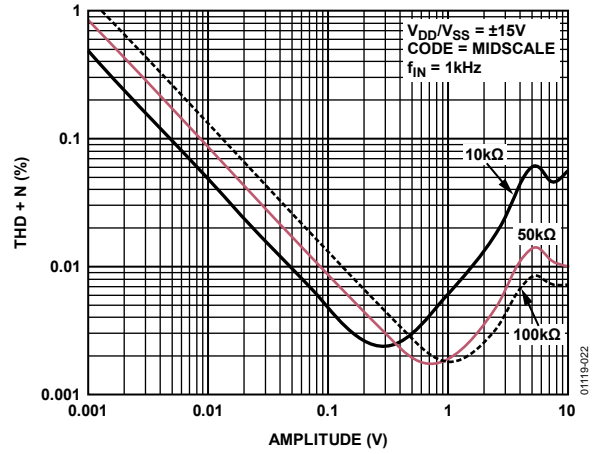

Figure 22. Total Harmonic Distortion Plus Noise vs. Amplitude

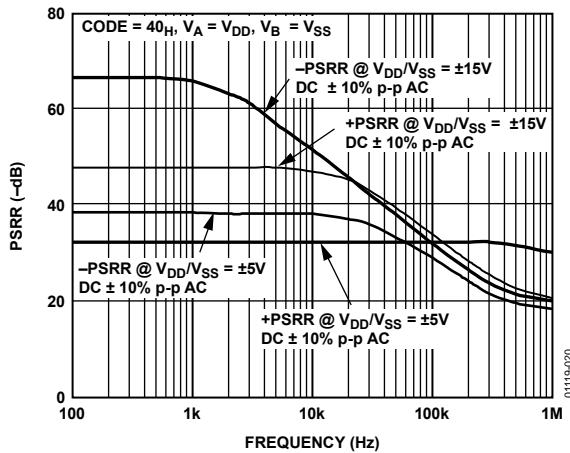

Figure 20. Power Supply Rejection vs. Frequency

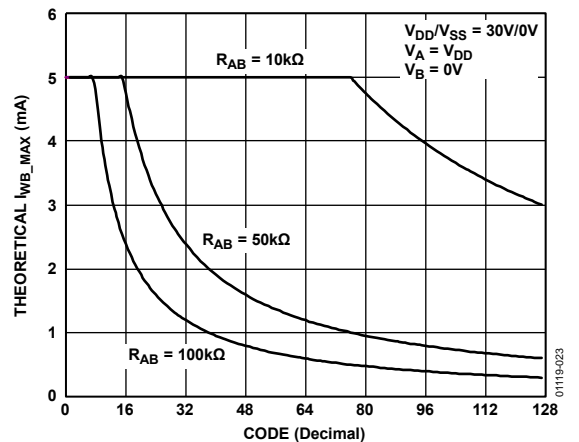

Figure 23. Theoretical Maximum Current vs. Code

THEORY OF OPERATION

PROGRAMMING THE VARIABLE RESISTOR

Rheostat Operation

The part operates in rheostat mode when only two terminals are used as a variable resistor. The unused terminal can be left floating or tied to the W terminal as shown in Figure 24.

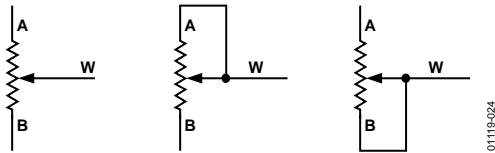

Figure 24. Rheostat Mode Configuration

The nominal resistance between Terminals A and B, R_{AB} , is available in 10 k Ω , 50 k Ω , and 100 k Ω with $\pm 30\%$ tolerance and has 128 tap points accessed by the wiper terminal. The 7-bit data in the RDAC latch is decoded to select one of the 128 possible settings. Figure 25 shows a simplified RDAC structure.

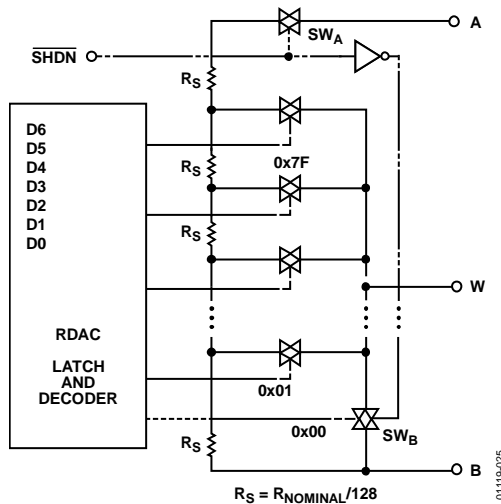

Figure 25. AD7376 Equivalent RDAC Circuit

The general equation determining the digitally programmed output resistance between the W and the B terminals is

$$R_{WB}(D) = \frac{D}{128} \times R_{AB} + R_W \quad (1)$$

where:

D is the decimal equivalent of the binary code loaded in the 7-bit RDAC register from 0 to 127.

R_{AB} is the end-to-end resistance.

R_W is the wiper resistance contributed by the on resistance of the internal switch.

The AD7376 wiper switches are designed with the transmission gate CMOS topology, and the gate voltage is derived from the V_{DD} . Each switch's on resistance, R_W , is a function of V_{DD} and temperature (see Figure 13).

Contrary to the temperature coefficient of R_{AB} , the temperature coefficient of the wiper resistance is significantly higher because the wiper resistance doubles with every 100° increase. As a result, the user must take into consideration the contribution of R_W on the desirable resistance. On the other hand, each switch's on resistance is insensitive to the tap point potential and remains relatively flat at 120 Ω typical at a V_{DD} of 15 V and a temperature of 25°C.

Assuming that a 10 k Ω part is used, the wiper's first connection starts at the B terminal for programming code 0x00, where SW_B is closed. The minimum resistance between Terminals W and B is therefore 120 Ω in general. The second connection is the first tap point, which corresponds to 198 Ω ($R_{WB} = 1/128 \times R_{AB} + R_W = 78 \Omega + 120 \Omega$) for programming code 0x01, and so on.

Each LSB data value increase moves the wiper up the resistor ladder until the last tap point is reached at 10,042 Ω ($R_{AB} - 1 \text{ LSB} + R_W$). Regardless of which settings the part is operating with, care should be taken to limit the current conducted between any A and B, W and A, or W and B terminals to a maximum dc current of 5 mA and a maximum pulse current of 20 mA. Otherwise, degradation or possible destruction of the internal switch contact can occur.

Similar to the mechanical potentiometer, the resistance of the RDAC between the W and A terminals also produces a digitally controlled complementary resistance, R_{WA} .

When these terminals are used, the B terminal can be opened. Setting the resistance value for R_{WA} starts at a maximum value of resistance and decreases as the data loaded into the latch increases in value. The general equation for this operation is

$$R_{WA}(D) = \frac{128 - D}{128} \times R_{AB} + R_W \quad (2)$$

PROGRAMMING THE POTENTIOMETER DIVIDER

Voltage Output Operation

The digital potentiometer easily generates a voltage divider at Wiper W to Terminal B and Wiper W to Terminal A that is proportional to the input voltage at Terminal A to Terminal B. Unlike the polarity of V_{DD} to GND, which must be positive, voltage across Terminal A to Terminal B, Wiper W to Terminal A, and Wiper W to Terminal B can be at either polarity.

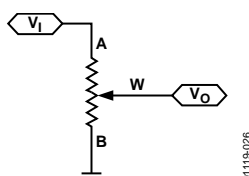

Figure 26. Potentiometer Mode Configuration

If ignoring the effect of the wiper resistance for the purpose of approximation, connecting the Terminal A to 30 V and the Terminal B to ground produces an output voltage at the Wiper W to Terminal B ranging from 0 V to 1 LSB less than 30 V. Each LSB of voltage is equal to the voltage applied across Terminals A and B divided by the 128 positions of the potentiometer divider. The general equation defining the output voltage at V_W with respect to ground for any valid input voltage applied to Terminals A and B is

$$V_W(D) = \frac{D}{128} V_A \quad (3)$$

A more accurate calculation that includes the effect of wiper resistance, V_W , is

$$V_W(D) = \frac{R_{WB}(D)}{R_{AB}} V_A + \frac{R_{WA}(D)}{R_{AB}} V_B \quad (4)$$

Operation of the digital potentiometer in the divider mode results in a more accurate operation over temperature. Unlike when in rheostat mode, the output voltage in divider mode is primarily dependent on the ratio, not the absolute values, of the internal resistors R_{WA} and R_{WB} . Therefore, the temperature drift reduces to 5 ppm/°C.

3-WIRE SERIAL BUS DIGITAL INTERFACE

The AD7376 contains a 3-wire digital interface (\overline{CS} , CLK, and SDI). The 7-bit serial word must be loaded MSB first. The format of the word is shown in Figure 2. The positive edge-sensitive CLK input requires clean transitions to avoid clocking incorrect data into the serial input register. Standard logic families work well. When \overline{CS} is low, the clock loads data into the serial register upon each positive clock edge.

The data setup and hold times in Table 3 determine the valid timing requirements. The AD7376 uses a 7-bit serial input data register word that is transferred to the internal RDAC register when the \overline{CS} line returns to logic high. Extra MSB bits are ignored.

The AD7376 powers up at a random setting. However, the midscale preset or any desirable preset can be achieved by manipulating \overline{RS} or \overline{SHDN} with an extra I/O.

When the reset (\overline{RS}) pin is asserted, the wiper resets to the midscale value. Midscale reset can be achieved dynamically or during power-up if an extra I/O is used.

When the \overline{SHDN} pin is asserted, the AD7376 opens SW_A to let the Terminal A float and to short Wiper W to Terminal B. The AD7376 consumes negligible power during the shutdown mode and resumes the previous setting once the \overline{SHDN} pin is released.

On the other hand, the AD7376 can be programmed with any settings during shutdown. With an extra programmable I/O asserting shutdown during power-up, this unique feature allows the AD7376 with programmable preset at any desirable level.

Table 7 shows the logic truth table for all operations.

Table 7. Input Logic Control Truth Table¹

CLK	\overline{CS}	\overline{RS}	\overline{SHDN}	Register Activity
L	L	H	H	Enables SR, enables SDO pin.
P	L	H	H	Shifts one bit in from the SDI pin. The seventh previously entered bit is shifted out of the SDO pin.
X	P	H	H	Loads SR data into 7-bit RDAC latch.
X	H	H	H	No operation.
X	X	L	H	Sets 7-bit RDAC latch to midscale, wiper centered, and SDO latch cleared.
X	H	P	H	Latches 7-bit RDAC latch to 0x40.
X	H	H	L	Opens circuit resistor of Terminal A, connects Wiper W to Terminal B, turns off SDO output transistor.

¹ P = positive edge, X = don't care, and SR = shift register.

DAISY-CHAIN OPERATION

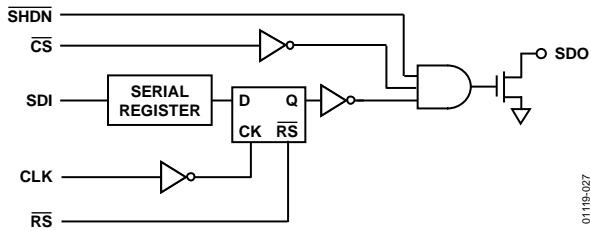

Figure 27. Detailed SDO Output Schematic of the AD7376

Figure 27 shows the details of the serial data output pin (SDO). SDO shifts out the SDI content in the previous frame; therefore, it can be used for daisy-chaining multiple devices. The SDO pin contains an open-drain N-Channel MOSFET and requires a pull-up resistor if the SDO function is used.

Users need to tie the SDO pin of one package to the SDI pin of the next package. For example, in Figure 28, if two AD7376s are daisy-chained, a total of 14 bits of data are required for each operation. The first set of seven bits goes to U2; the second set of seven bits goes to U1. \overline{CS} should be kept low until all 14 bits are clocked into their respective serial registers. Then \overline{CS} is pulled high to complete the operation.

When daisy-chaining multiple devices, users may need to increase the clock period because the pull-up resistor and the capacitive loading at the SDO to SDI interface may induce a time delay to subsequent devices.

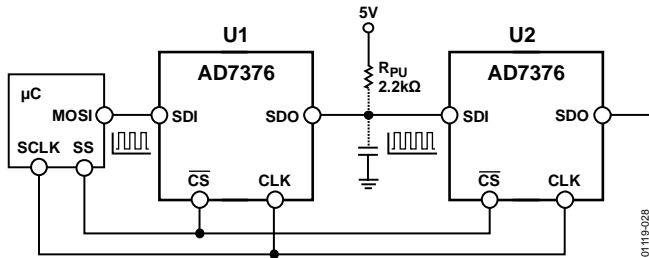

Figure 28. Daisy-Chain Configuration

ESD PROTECTION

All digital inputs are protected with a series input resistor and an ESD structure shown in Figure 29. These structures apply to digital input pins \overline{CS} , CLK, SDI, RS, and \overline{SHDN} .

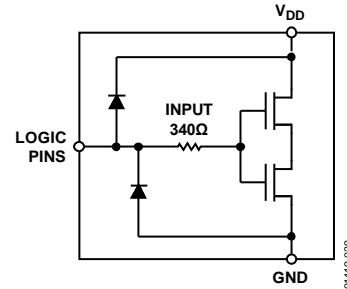

Figure 29. Equivalent ESD Protection Circuit

All analog terminals are also protected by ESD protection diodes, as shown in Figure 30.

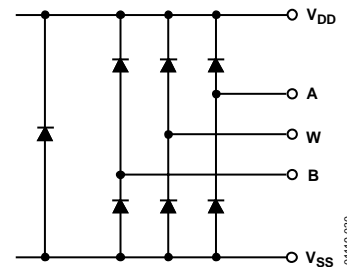

Figure 30. Equivalent ESD Protection Analog Pins

TERMINAL VOLTAGE OPERATING RANGE

The AD7376 V_{DD} and V_{SS} power supplies define the boundary conditions for proper 3-terminal digital potentiometer operation. Applied signals present on Terminals A, B, and W that are more positive than V_{DD} or more negative than V_{SS} will be clamped by the internal forward-biased diodes (see Figure 30).

POWER-UP AND POWER-DOWN SEQUENCES

Because of the ESD protection diodes that limit the voltage compliance at Terminals A, B, and W (see Figure 30), it is important to power V_{DD}/V_{SS} before applying voltage to Terminals A, B, and W. Otherwise, the diodes are forward biased such that V_{DD}/V_{SS} are powered unintentionally and affect the system. Similarly, V_{DD}/V_{SS} should be powered down last. The ideal power-up sequence is in the following order: GND, V_{DD} , V_{SS} , digital inputs, and $V_A/V_B/V_W$. The order of powering V_A , V_B , V_W , and the digital inputs is not important, as long as they are powered after V_{DD}/V_{SS} .

LAYOUT AND POWER SUPPLY BIASING

It is a good practice to employ a compact, minimum lead-length layout design. The leads to the input should be as direct as possible, with a minimum conductor length. Ground paths should have low resistance and low inductance.

Similarly, it is also good practice to bypass the power supplies with quality capacitors. Low ESR (equivalent series resistance) 1 μF to 10 μF tantalum or electrolytic capacitors should be applied at the supplies to minimize transient disturbances and filter low frequency ripple. Figure 31 illustrates the basic supply bypassing configuration for the AD7376.

The ground pin of the AD7376 is a digital ground reference. To minimize the digital ground bounce, the AD7376 digital ground terminal should be joined remotely to the analog ground (see Figure 31).

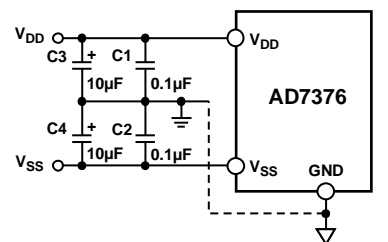

Figure 31. Power Supply Bypassing

01119-031

APPLICATIONS INFORMATION

HIGH VOLTAGE DAC

The AD7376 can be configured as a high voltage DAC as high as 30 V. The circuit is shown in Figure 32. The output is

$$V_o(D) = \frac{D}{128} \left[1.2 \text{ V} \times \left(1 + \frac{R_2}{R_1} \right) \right] \quad (5)$$

Where D is the decimal code from 0 to 127.

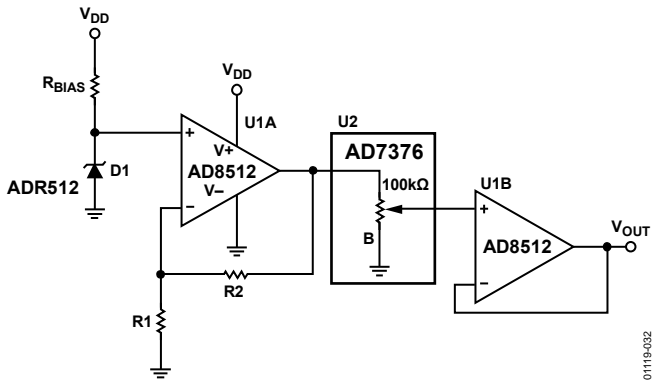

Figure 32. High Voltage DAC

01119-032

PROGRAMMABLE POWER SUPPLY

With a boost regulator such as ADP1611, AD7376 can be used as the variable resistor at the regulator's FB pin to provide the programmable power supply (see Figure 33). The output is

$$V_o = 1.23 \text{ V} \times \left[1 + \frac{\left(\frac{D}{128} \right) \times R_{AB}}{R_2} \right] \quad (6)$$

Note that the AD7376's V_{DD} is derived from the output. Initially L_1 acts as a short, and V_{DD} is one diode voltage drop below +5 V. The output slowly establishes to the final value.

The AD7376 shutdown sleep-mode programming can be used to program a desirable preset level at power-up.

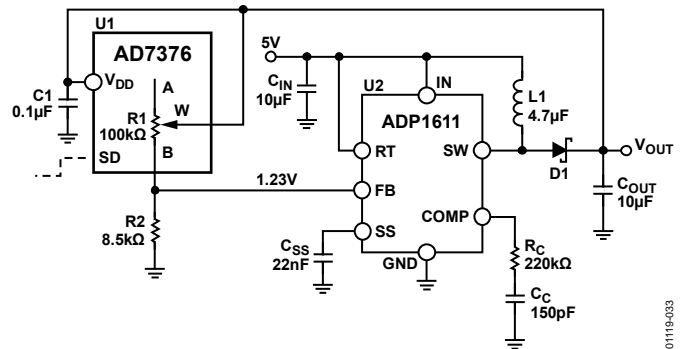

Figure 33. Programmable Power Supply

01119-033

AUDIO VOLUME CONTROL

Because of its good THD performance and high voltage capability, the AD7376 can be used for digital volume control. If AD7376 is used directly as an audio attenuator or gain amplifier, a large step change in the volume level at any arbitrary time can lead to an abrupt discontinuity of the audio signal, causing an audible zipper noise. To prevent this, a zero-crossing window detector can be inserted to the $\overline{\text{CS}}$ line to delay the device update until the audio signal crosses the window. Since the input signal can operate on top of any dc levels rather than absolute zero volt level, zero-crossing, in this case, means the signal is ac-coupled and the dc offset level is the signal zero reference point.

The configuration to reduce zipper noise and the result of using this configuration are shown in Figure 35 and Figure 34, respectively. The input is ac-coupled by C1 and attenuated down before feeding into the window comparator formed by U2, U3, and U4B. U6 is used to establish the signal zero reference. The upper limit of the comparator is set above its offset and, therefore, the output pulses high whenever the input falls between 2.502 V and 2.497 V (or 0.005 V window) in this example. This output is AND'd with the chip select signal such that the AD7376 updates whenever the signal crosses the window. To avoid constant update of the device, the chip select signal should be programmed as two pulses, rather than the one shown in Figure 2.

In Figure 34, the lower trace shows that the volume level changes from a quarter scale to full scale when a signal change occurs near the zero-crossing window.

The AD7376 shutdown sleep-mode programming feature can be used to mute the device at power-up by holding SHDN low and programming zero scale.

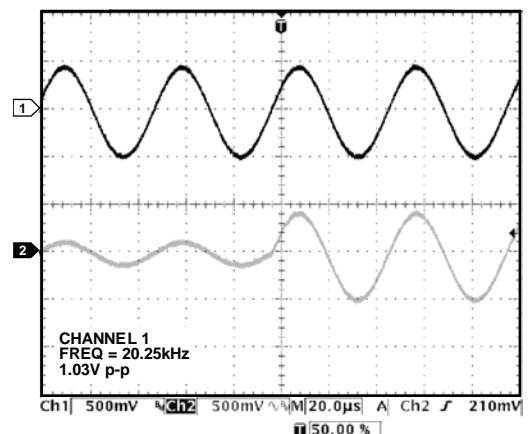

NOTES

1. THE LOWER TRACE SHOWS THAT THE VOLUME LEVEL CHANGES FROM QUARTER SCALE TO FULL SCALE, WITH THE CHANGE OCCURRING NEAR THE ZERO-CROSSING WINDOW.

Figure 34. Input (Trace 1) and Output (Trace 2) of the Circuit in Figure 35

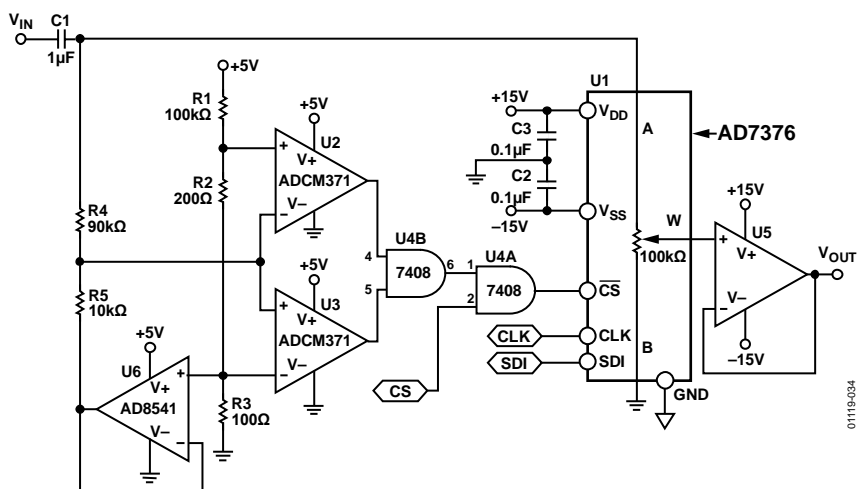
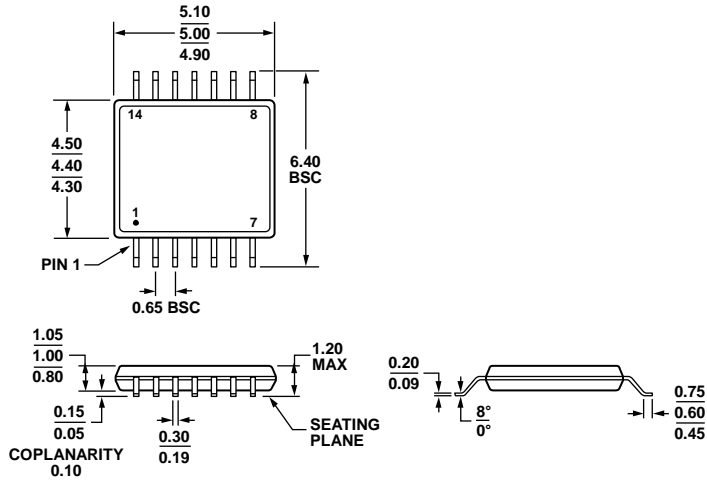

Figure 35. Audio Volume Control with Zipper Noise Reduction

OUTLINE DIMENSIONS



COMPLIANT TO JEDEC STANDARDS MO-153-AB-1

Figure 36. 14-Lead Thin Shrink Small Outline Package [TSSOP] (RU-14)
Dimensions shown in millimeters

061908-A

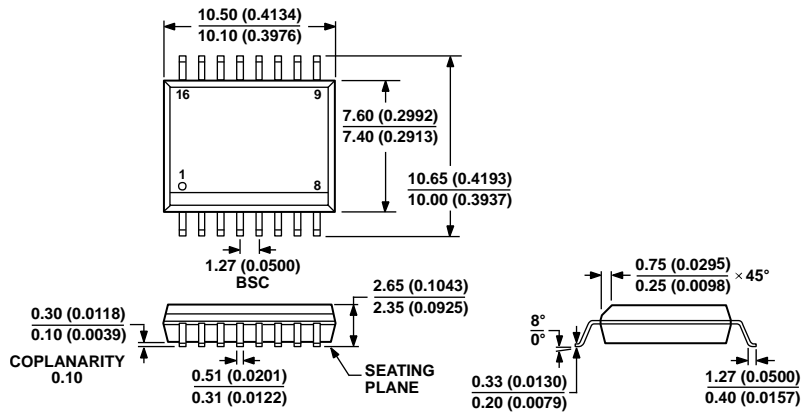

COMPLIANT TO JEDEC STANDARDS MS-013-AA
CONTROLLING DIMENSIONS ARE IN MILLIMETERS; INCH DIMENSIONS (IN PARENTHESES) ARE ROUNDED-OFF MILLIMETER EQUIVALENTS FOR REFERENCE ONLY AND ARE NOT APPROPRIATE FOR USE IN DESIGN.

Figure 37. 16-Lead Standard Small Outline Package [SOIC_W] Wide Body (RW-16)
Dimensions shown in millimeters and (inches)

03-27-2007-B

ORDERING GUIDE

Model ¹	kΩ	Temperature Range	Package Description ^{2, 3}	Package Option	Ordering Quantity
AD7376ARUZ10	10	-40°C to +85°C	14-Lead TSSOP	RU-14	96
AD7376ARUZ10-R7	10	-40°C to +85°C	14-Lead TSSOP	RU-14	1,000
AD7376ARWZ10	10	-40°C to +85°C	16-Lead SOIC_W	RW-16	47
AD7376ARWZ10-RL	10	-40°C to +85°C	16-Lead SOIC_W	RW-16	1,000
AD7376ARUZ50-REEL7	50	-40°C to +85°C	14-Lead TSSOP	RU-14	1,000
AD7376ARUZ50	50	-40°C to +85°C	14-Lead TSSOP	RU-14	96
AD7376ARWZ50	50	-40°C to +85°C	16-Lead SOIC_W	RW-16	47
AD7376ARUZ100	100	-40°C to +85°C	14-Lead TSSOP	RU-14	96
AD7376ARUZ100-R7	100	-40°C to +85°C	14-Lead TSSOP	RU-14	1,000
AD7376ARWZ100	100	-40°C to +85°C	16-Lead SOIC_W	RW-16	47
EVAL-AD7376EBZ	10				1

¹ Z = RoHS Compliant Part.

² In SOIC RW-16 package top marking: line 1 shows AD7376; line 2 shows the branding information, where A10 = 10 kΩ, A50 = 50 kΩ, and A100 = 100 kΩ; line 3 shows a “#” top marking with the date code in YYWW; and line 4 shows the lot number.

³ In TSSOP-14 package top marking: line 1 shows 7376; line 2 shows the branding information, where A10 = 10 kΩ, A50 = 50 kΩ, and A100 = 100 kΩ; line 3 shows a “#” top marking with the date code in YWW; back side shows the lot number.

AD7376

NOTES