

FEATURES

- 120 dB dynamic range at 78 kHz output data rate
- 109 dB dynamic range at 625 kHz output data rate
- 112 dB SNR at 78 kHz output data rate
- 107 dB SNR at 625 kHz output data rate
- 625 kHz maximum fully filtered output word rate
- Programmable oversampling rate (32× to 256×)
- Flexible serial interface
- Fully differential modulator input
- On-chip differential amplifier for signal buffering
- Low-pass finite impulse response (FIR) filter with default or user-programmable coefficients
- Overrange alert bit
- Digital offset and gain correction registers
- Low power and power-down modes
- Synchronization of multiple devices via $\overline{\text{SYNC}}$ pin I²S interface mode

APPLICATIONS

- Data acquisition systems
- Vibration analysis
- Instrumentation

GENERAL DESCRIPTION

The **AD7763** high performance, 24-bit, Σ - Δ analog-to-digital converter (ADC) combines wide input bandwidth and high speed with the benefits of Σ - Δ conversion, as well as performance of 107 dB SNR at 625 kSPS, making it ideal for high speed data acquisition. A wide dynamic range, combined with significantly reduced antialiasing requirements, simplifies the design process. An integrated buffer to drive the reference, a differential amplifier for signal buffering and level shifting, an overrange flag, internal gain and offset registers, and a low-pass, digital FIR filter make the **AD7763** a compact, highly integrated data acquisition device requiring minimal peripheral component selection. In addition, the device offers programmable decimation rates and a digital FIR filter, which can be user-programmed to ensure that its characteristics are tailored for the user's application. The **AD7763** is ideal for applications demanding high SNR without necessitating the design of complex, front-end signal processing.

FUNCTIONAL BLOCK DIAGRAM

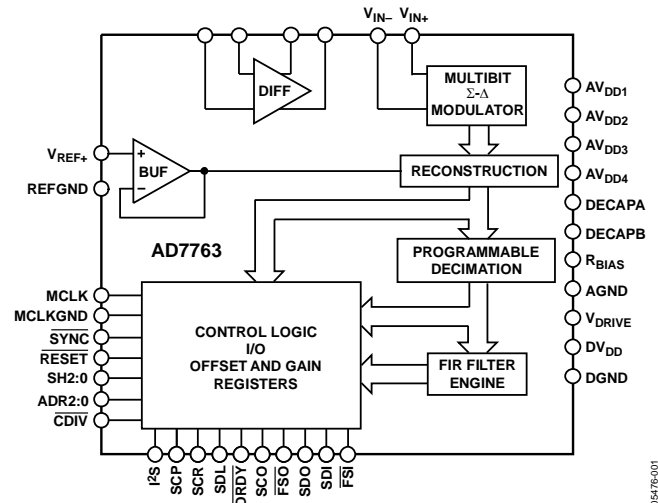

Figure 1.

The differential input is sampled at up to 40 MSPS by an analog modulator. The modulator output is processed by a series of low-pass filters, the final filter having default or user-programmable coefficients. The sample rate, filter corner frequencies, and output word rate are set by a combination of the external clock frequency and the configuration registers of the **AD7763**.

The reference voltage supplied to the **AD7763** determines the analog input range. With a 4 V reference, the analog input range is ± 3.2 V differential-biased around a common mode of 2 V. This common-mode biasing can be achieved using the on-chip differential amplifiers, further reducing the external signal conditioning requirements.

The **AD7763** is available in an exposed paddle, 64-lead TQFP_EP and is specified over the industrial temperature range from -40°C to $+85^{\circ}\text{C}$.

Table 1. Related Devices

Part No.	Description
AD7760	24-bit, 2.5 MSPS, 100 dB Σ - Δ , parallel interface
AD7762	24-bit, 625 kSPS, 109 dB Σ - Δ , parallel interface

Rev. B

[Document Feedback](#)

Information furnished by Analog Devices is believed to be accurate and reliable. However, no responsibility is assumed by Analog Devices for its use, nor for any infringements of patents or other rights of third parties that may result from its use. Specifications subject to change without notice. No license is granted by implication or otherwise under any patent or patent rights of Analog Devices. Trademarks and registered trademarks are the property of their respective owners.

AD7763* Product Page Quick Links

Last Content Update: 08/30/2016

Comparable Parts

View a parametric search of comparable parts

Evaluation Kits

- AD7763 Evaluation Kit

Documentation

Application Notes

- AN-280: Mixed Signal Circuit Technologies
- AN-282: Fundamentals of Sampled Data Systems
- AN-283: Sigma-Delta ADCs and DACs
- AN-311: How to Reliably Protect CMOS Circuits Against Power Supply Overvoluting
- AN-342: Analog Signal-Handling for High Speed and Accuracy
- AN-388: Using Sigma-Delta Converters-Part 1
- AN-389: Using Sigma-Delta Converters-Part 2

Data Sheet

- AD7763: 24-Bit, 625 kSPS, 109 dB Sigma-Delta ADC with On Chip Buffers, Serial Interface Data Sheet

Software and Systems Requirements

- CED1Z FPGA Project for AD7763 with Nios driver
- EVAL-AD7763EDZ - AD7763 Evaluation Board - Software

Tools and Simulations

- Sigma-Delta ADC Tutorial

Reference Materials

Technical Articles

- MS-2210: Designing Power Supplies for High Speed ADC
- Vibration Analysis Using ADCs Keeps Industrial Equipment Working

Design Resources

- AD7763 Material Declaration
- PCN-PDN Information
- Quality And Reliability
- Symbols and Footprints

Discussions

View all AD7763 EngineerZone Discussions

Sample and Buy

Visit the product page to see pricing options

Technical Support

Submit a technical question or find your regional support number

TABLE OF CONTENTS

Features	1	Example 2	19
Applications.....	1	Driving the AD7763.....	20
Functional Block Diagram	1	Using the AD7763	21
General Description	1	Bias Resistor Selection	21
Revision History	2	Decoupling and Layout Recommendations.....	22
Specifications.....	3	Supply Decoupling.....	23
Timing Specifications.....	5	Additional Decoupling	23
Timing Diagrams.....	6	Reference Voltage Filtering	23
Absolute Maximum Ratings.....	7	Differential Amplifier Components	23
ESD Caution.....	7	Exposed Paddle.....	23
Pin Configuration and Function Descriptions.....	8	Layout Considerations.....	23
Terminology	10	Programmable FIR Filter.....	24
Typical Performance Characteristics	11	Downloading a User-Defined Filter	25
Theory of Operation	14	Example Filter Download	26
AD7763 Interface.....	15	Registers.....	27
Reading Data Using the SPI Interface	15	Control Register 1—Address 0x001.....	27
Synchronization.....	15	Control Register 2—Address 0x002.....	27
Sharing the Serial Bus	15	Status Register (Read Only)	28
Writing to the AD7763	16	Offset Register—Address 0x003.....	28
Reading Status and Other Registers.....	17	Gain Register—Address 0x004	28
Reading Data Using the I ² S Interface.....	18	Overrange Register—Address 0x005.....	28
Clocking the AD7763.....	19	Outline Dimensions	29
Example 1	19	Ordering Guide	29

REVISION HISTORY

1/14—Rev. A to Rev. B

Added Exposed Pad Notation, Figure 4 and Table 5	8
Change to Figure 37	24
Updated Outline Dimensions	29

11/09—Rev. 0 to Rev. A

Changes to Figure 5.....	8
Changes to Sharing the Serial Bus Section	15
Changes to Figure 26.....	16
Updated Outline Dimensions	29
Changes to Ordering Guide	29

10/05—Revision 0: Initial Version

SPECIFICATIONS

$AV_{DD1} = DV_{DD} = V_{DRIVE} = 2.5\text{ V}$; $AV_{DD2} = AV_{DD3} = AV_{DD4} = 5\text{ V}$; $V_{REF} = 4.096\text{ V}$; MCLK amplitude = 5 V; $T_A = 25^\circ\text{C}$; normal mode, using on-chip amplifier with components as shown in Table 10, unless otherwise noted.¹

Table 2.

Parameter	Test Conditions/Comments	Specification	Unit
DYNAMIC PERFORMANCE			
Decimate × 256 Dynamic Range	MCLK = 40 MHz, ODR = 78 kHz, $F_{IN} = 1\text{ kHz}$ Modulator inputs shorted	119 120.5	dB min dB typ
Signal-to-Noise Ratio (SNR) ²	Input amplitude = -0.5 dBFS	112	dB typ
	Input amplitude = -60 dB	59	dBc typ
Spurious-Free Dynamic Range (SFDR)	Nonharmonic, input amplitude = -6 dB	126	dBc typ
	Input amplitude = -60 dB	77	dBc typ
Total Harmonic Distortion (THD)	Input amplitude = -0.5 dBFS	-105	dB typ
	Input amplitude = -6 dB	-106	dBc typ
	Input amplitude = -60 dB	-75	dBc typ
Decimate × 64 Dynamic Range	MCLK = 40 MHz, ODR = 312.5 kHz, $F_{IN} = 1\text{ kHz}$ Modulator inputs shorted	112 113	dB min dB typ
Signal-to-Noise Ratio (SNR) ²	Input amplitude = -0.5 dBFS	109.5	dB typ
Spurious-Free Dynamic Range (SFDR)	Nonharmonic, input amplitude = -6 dB	126	dBc typ
Decimate × 32 Dynamic Range	MCLK = 40 MHz, ODR = 625 kHz, $F_{IN} = 100\text{ kHz}$ Modulator inputs shorted	108 109.5	dB min dB typ
Signal-to-Noise Ratio (SNR) ²	Input amplitude = -0.5 dBFS	107	dB typ
Spurious-Free Dynamic Range (SFDR)	Nonharmonic, input amplitude = -6 dB	120	dBc typ
Total Harmonic Distortion (THD)	Input amplitude = -0.5 dBFS	-105	dB typ
	Input amplitude = -6 dB	-107	dBc typ
DC ACCURACY			
Resolution	Guaranteed monotonic to 24 bits	24	Bits
Differential Nonlinearity		0.00076	% typ
Integral Nonlinearity		0.014	% typ
Zero Error		0.02	% max
Gain Error		0.018	% typ
Zero Error Drift		10	$\mu\text{FS}/^\circ\text{C}$ typ
Gain Error Drift		0.0002	$\text{FS}/^\circ\text{C}$ typ
DIGITAL FILTER RESPONSE			
Decimate × 32 Group Delay	MCLK = 40 MHz	47	μs typ
Decimate × 64 Group Delay	MCLK = 40 MHz	91.5	μs typ
Decimate × 256 Group Delay	MCLK = 40 MHz	358	μs typ
ANALOG INPUT			
Differential Input Voltage	$V_{IN(+)} - V_{IN(-)}$, $V_{REF} = 2.5\text{ V}$	± 2	V p-p
	$V_{IN(+)} - V_{IN(-)}$, $V_{REF} = 4.096\text{ V}$	± 3.25	V p-p
Input Capacitance	At internal buffer inputs	5	pF typ
	At modulator inputs	55	pF typ

Parameter	Test Conditions/Comments	Specification	Unit
REFERENCE INPUT			
V_{REF} Input Voltage	$V_{DD3} = 3.3\text{ V} \pm 5\%$ $V_{DD3} = 5\text{ V} \pm 5\%$	+2.5 +4.096	V max V max
V_{REF} Input DC Leakage Current		± 1	μA max
V_{REF} Input Capacitance		5	pF max
POWER DISSIPATION			
Total Power Dissipation	Normal power mode Low power mode	955.5 651	mW max mW max
Standby Mode	Clock stopped	6.35	mW typ
POWER REQUIREMENTS			
AV_{DD1} (Modulator Supply)	$\pm 5\%$	+2.5	V
AV_{DD2} (General Supply)	$\pm 5\%$	+5	V
AV_{DD3} (Differential Amplifier Supply)		+3.15/+5.25	V min/max
AV_{DD4} (Reference Buffer Supply)		+3.15/+5.25	V min/max
DV_{DD}	$\pm 5\%$	+2.5	V
V_{DRIVE}		+1.65/+2.7	V min/max
Normal Mode			
AI_{DD1} (Modulator)		49/52	mA typ/max
AI_{DD2} (General)		40/43	mA typ/max
AI_{DD4} (Reference Buffer)	$AV_{DD4} = 5\text{ V}$	35/37	mA typ/max
Low Power Mode			
AI_{DD1} (Modulator)		26/28	mA typ/max
AI_{DD2} (General)		20/23	mA typ/max
AI_{DD4} (Reference Buffer)	$AV_{DD4} = 5\text{ V}$	10/11	mA typ/max
AI_{DD3} (Diff Amp)	$AV_{DD3} = 5\text{ V}$, both modes	41/45	mA typ/max
DI_{DD}	Both modes	56/62	mA typ/max
DIGITAL I/O			
MCLK Input Amplitude ³		5	V typ
Input Capacitance		7.3	pF typ
Input Leakage Current		± 1	$\mu\text{A}/\text{pin}$ max
Three-State Leakage Current (SDO)		± 1	μA max
V_{INH}		$0.7 \times V_{DRIVE}$	V min
V_{INL}		$0.3 \times V_{DRIVE}$	V max
V_{OH} ⁴		1.5	V min
V_{OL}		0.1	V max

¹ See the Terminology section.

² SNR specifications in dB are referred to a full-scale input, FS, and tested with an input signal at 0.5 dB below full scale, unless otherwise specified.

³ While the AD7763 can function with an MCLK amplitude of less than 5 V, this is the recommended amplitude to achieve the performance as stated.

⁴ Tested with a 400 μA load current.

TIMING SPECIFICATIONS

$AV_{DD1} = DV_{DD} = V_{DRIVE} = 2.5\text{ V}$, $AV_{DD2} = AV_{DD3} = AV_{DD4} = 5\text{ V}$, $T_A = 25^\circ\text{C}$, normal mode, unless otherwise noted.

Table 3.

Parameter	Limit at T_{MIN} , T_{MAX}	Unit	Description
f_{MCLK}	1 40	MHz min MHz max	Applied master clock frequency
f_{iCLK}	500 20	kHz min MHz max	Internal modulator clock derived from MCLK
t_1^1	$1 \times t_{iCLK}$ OR $0.5 \times t_{iCLK}^2$	typ	SCO high period
t_2^1	$1 \times t_{iCLK}$ OR $0.5 \times t_{iCLK}^2$	typ	SCO low period
t_3	t_{SCO}^3	typ	\overline{DRDY} low period
t_{3A}^4	2	ns typ	SCO rising edge to \overline{DRDY} falling edge
t_{3B}^4	3	ns typ	SCO rising edge to \overline{DRDY} rising edge
t_4^5	$32 \times t_{SCO}^3$	typ	\overline{FSO} low period
$t_{4A}^{4,5}$	1	ns typ	SCO rising edge to \overline{FSO} falling edge
$t_{4B}^{4,5}$	2	ns typ	SCO falling edge to \overline{FSO} rising edge
t_5	6.5	ns max	Initial data access time
t_6^4	5	ns max	SCO rising edge to SDO valid
t_7	$0.5 \times t_{SCO}^3$	ns min	SDO valid after SCO falling edge
t_8	$16 \times t_{SCO}^3$	typ	\overline{DRDY} rising edge to SDL falling edge
t_9	t_{SCO}^3	typ	SDL pulse width
t_{10}	5.5	ns max	SDO three-state to SCO rising edge
t_{11}	$1 \times t_{SCO}^3$	min	\overline{FSI} low period
t_{12}	12	ns min	SDI setup time
t_{13}	10	ns min	SDI hold time
t_{14}	12	ns min	\overline{FSI} setup time
t_{15}	$16 \times t_{SCO}^3$	typ	SDL falling edge to SDL falling edge

¹ $t_{iCLK} = 1/f_{iCLK}$.

² SCO frequency selected by SCR and \overline{CDIV} pins.

³ $t_{SCO} = t_1 + t_2$.

⁴ All edges mentioned refer to SCP = 0. Invert SCO edges for SCP = 1.

⁵ In decimate $\times 32$ mode, this time specification applies only when $\overline{CDIV} = 0$ and SCR = 1. For all other combinations of \overline{CDIV} and SCR in decimate $\times 32$ mode, the FSO signal is constantly logic low.

TIMING DIAGRAMS

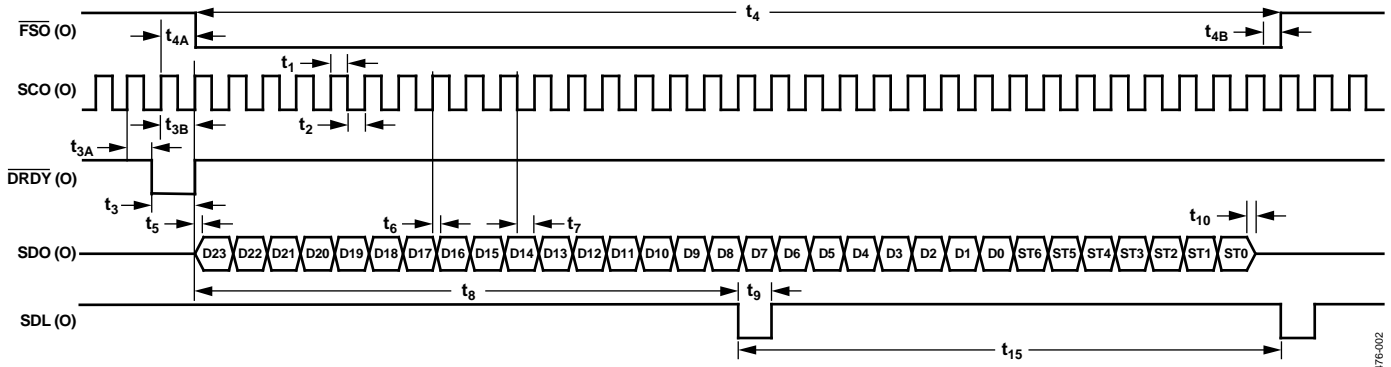

Figure 2. SPI® Interface Serial Read Timing Diagram

05476-002

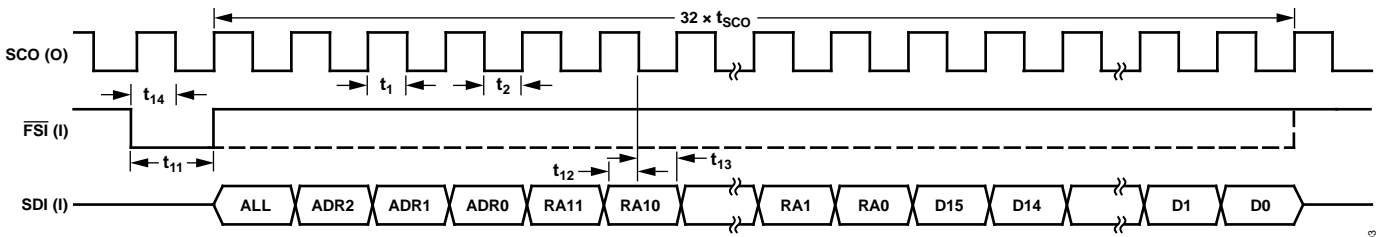

Figure 3. Register Write

05476-003

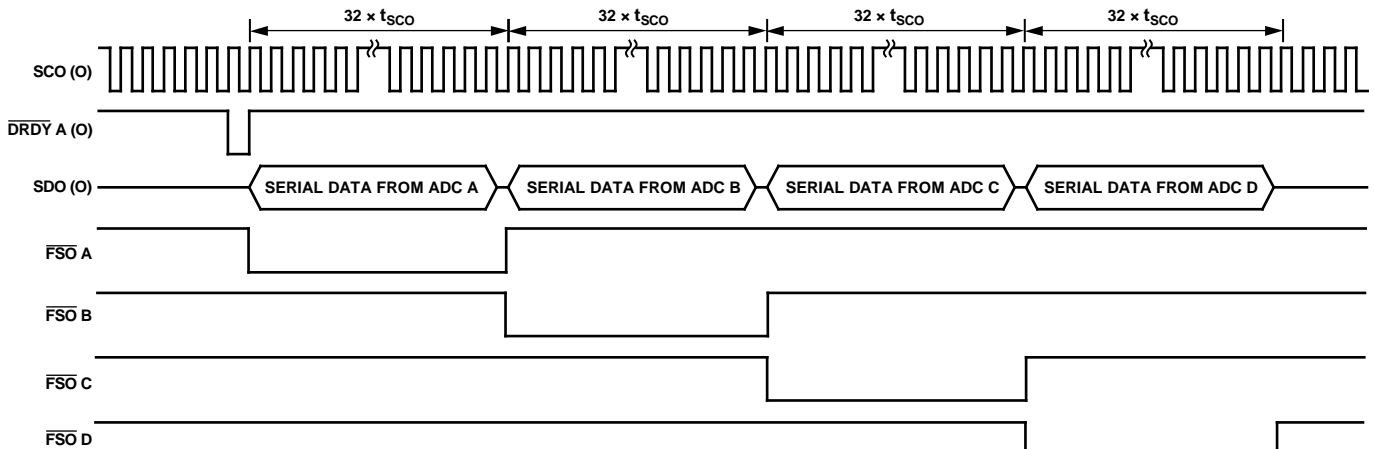

Figure 4. SPI Interface Serial Read Timing with Multiple AD7763 Devices Sharing the Serial Bus

05476-004

ABSOLUTE MAXIMUM RATINGS

$T_A = 25^\circ\text{C}$, unless otherwise noted.

Table 4.

Parameter	Rating
AV_{DD1} to GND	-0.3 V to +3 V
(AV_{DD2} , AV_{DD3} , AV_{DD4}) to GND	-0.3 V to +6 V
DV_{DD} to GND	-0.3 V to +3 V
V_{DRIVE} to GND	-0.3 V to +3 V
V_{IN+} , V_{IN-} to GND	-0.3 V to +6 V
Digital Input Voltage to GND ¹	-0.3 V to $DV_{DD} + 0.3$ V
MCLK to MCLKGND	-0.3 V to +6 V
V_{REF} to GND ²	-0.3 V to $AV_{DD4} + 0.3$ V
AGND to DGND	-0.3 V to +0.3 V
Input Current to Any Pin Except Supplies ³	± 10 mA
Operating Temperature Range Commercial	-40°C to +85°C
Storage Temperature Range	-65°C to +150°C
Junction Temperature	150°C
TQFP_EP Exposed Paddle	
θ_{JA} Thermal Impedance	92.7°C/W
θ_{JC} Thermal Impedance	5.1°C/W
Lead Temperature, Soldering	
Vapor Phase (60 sec)	215°C
Infrared (15 sec)	220°C
ESD	600 V

¹ Absolute maximum voltage on digital inputs is 3.0 V or $DV_{DD} + 0.3$ V, whichever is lower.

² Absolute maximum voltage on V_{REF} input is 6.0 V or $AV_{DD4} + 0.3$ V, whichever is lower.

³ Transient currents of up to 200 mA do not cause SCR latch-up.

Stresses above those listed under Absolute Maximum Ratings may cause permanent damage to the device. This is a stress rating only; functional operation of the device at these or any other conditions above those indicated in the operational section of this specification is not implied. Exposure to absolute maximum rating conditions for extended periods may affect device reliability.

ESD CAUTION



ESD (electrostatic discharge) sensitive device. Charged devices and circuit boards can discharge without detection. Although this product features patented or proprietary protection circuitry, damage may occur on devices subjected to high energy ESD. Therefore, proper ESD precautions should be taken to avoid performance degradation or loss of functionality.

PIN CONFIGURATION AND FUNCTION DESCRIPTIONS

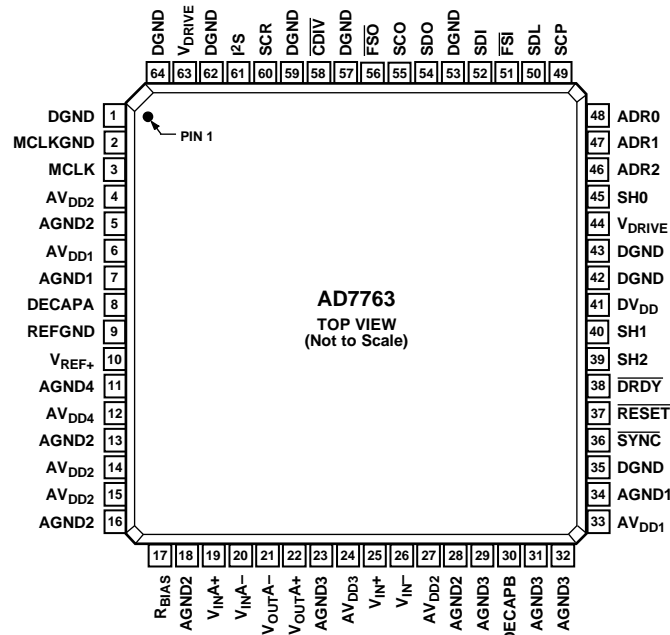

- NOTES**
 1. CONNECT THE EXPOSED PAD TO AGNDx WITH SIX TO EIGHT VIAS.

Figure 5. Pin Configuration

Table 5. Pin Function Descriptions

Pin No.	Mnemonic	Description
6, 33	AV _{DD1}	Power Supply for Modulator, 2.5 V. These pins should be decoupled to AGND1 with 100 nF and 10 μF capacitors on each pin.
4, 14, 15, 27	AV _{DD2}	Power Supply, 5 V. These pins should be decoupled to AGND2 with 100 nF capacitors on each of Pin 4, Pin 14, and Pin 15. Pin 27 should be connected to Pin 14 via an 8.2 nH inductor.
24	AV _{DD3}	Power Supply for Differential Amplifier, 3.3 V to 5 V. This pin should be decoupled to AGND3 with a 100 nF capacitor.
12	AV _{DD4}	Power Supply for Reference Buffer, 3.3 V to 5 V. This pin should be decoupled to AGND4 with a 10 nF capacitor in series with a 10 Ω resistor.
7, 34	AGND1	Power Supply Ground for Analog Circuitry Powered by AV _{DD1} .
5, 13, 16, 18, 28	AGND2	Power Supply Ground for Analog Circuitry Powered by AV _{DD2} .
23, 29, 31, 32	AGND3	Power Supply Ground for Analog Circuitry Powered by AV _{DD3} .
11	AGND4	Power Supply Ground for Analog Circuitry Powered by AV _{DD4} .
9	REFGND	Reference Ground. Ground connection for the reference voltage.
41	DV _{DD}	Power Supply for Digital Circuitry and FIR Filter, 2.5 V. This pin should be decoupled to DGND with a 100 nF capacitor.
44, 63	V _{DRIVE}	Logic Power Supply Input, 1.8 V to 2.5 V. The voltage supplied at these pins determines the operating voltage of the logic interface. These pins must be connected together and tied to the same supply. Each pin should also be decoupled to DGND with a 100 nF capacitor.
1, 35, 42, 43, 53, 57, 59, 62, 64	DGND	Ground Reference for Digital Circuitry.
19	V _{IN+}	Positive Input to Differential Amplifier.
20	V _{IN-}	Negative Input to Differential Amplifier.
21	V _{OUT-}	Negative Output from Differential Amplifier.
22	V _{OUT+}	Positive Output from Differential Amplifier.
25	V _{IN+}	Positive Input to the Modulator.
26	V _{IN-}	Negative Input to the Modulator.
10	V _{REF+}	Reference Input. The input range of this pin is determined by the reference buffer supply voltage (AV _{DD4}). See the Reference Voltage Filtering section for more details.

Pin No.	Mnemonic	Description
8	DECAPA	Decoupling Pin. A 100 nF capacitor must be inserted between this pin and AGND1.
30	DECAPB	Decoupling Pin. A 33 pF capacitor must be inserted between this pin and AGND3.
17	R _{BIAS}	Bias Current Setting. A resistor must be inserted between this pin and AGND. See the Bias Resistor Selection section.
37	$\overline{\text{RESET}}$	A falling edge on this pin resets all internal digital circuitry. Holding this pin low keeps the AD7763 in a reset state.
3	MCLK	Master Clock Input. A low jitter digital clock must be applied to this pin. The output data rate depends on the frequency of this clock. See the Clocking the AD7763 section.
2	MCLKGND	Master Clock Ground Sensing Pin.
36	$\overline{\text{SYNC}}$	Synchronization Input. A falling edge on this pin resets the internal filter. This can be used to synchronize multiple devices in a system.
38	$\overline{\text{DRDY}}$	Data Ready Output. Each time new conversion data is available, an active low pulse, ½ ICLK period wide, is produced on this pin. See the AD7763 Interface section.
39, 40, 45	SH2:0	Share Pins 2:0. For multiple AD7763 devices sharing a common serial bus. Each device is wired with the binary value that represents the number of devices sharing the serial bus. SH2 is the MSB. See the Sharing the Serial Bus section.
46 to 48	ADR2:0	Address 2:0. Allows multiple AD7763 devices to share a common serial bus. Each device must be programmed with an individual address using these three pins. See the Sharing the Serial Bus section.
49	SCP	Serial Clock Polarity. Determines on which edge of SCO the data bits are clocked out and on which edge they are valid. All timing diagrams are shown with SCP = 0, and all SCO edges shown should be inverted for SCP = 1.
50	SDL	Serial Data Latch. A pulse is output on this pin after every 16 data bits. The pulse is one SCO period wide and can be used in conjunction with FSO as an alternative framing method for serial transfers requiring a framing signal more frequent than every 32 bits.
51	$\overline{\text{FSI}}$	Frame Sync In. The status of this pin is checked on the falling edge of SCO. If this pin is low, then the first data bit is latched in on the next SCO falling edge when SCP = 0 or on the rising edge of SCO if SCP = 1.
52	SDI	Serial Data In. The first data bit (MSB) must be valid on the next SCO falling edge when SCP = 0 (or SCO rising edge SCP = 1) after the $\overline{\text{FSI}}$ event has been latched. Each write requires 32 bits: the ALL bit, 3 address bits, and 12 register address bits, followed by the remaining 16 bits of data to be written to the device.
54	SDO	Serial Data Out. Address, status, and data bits are clocked out on this line during each serial transfer. If SCP = 0, each bit is clocked out on an SCO rising edge and is valid on the falling edge. When the I ² S pin is set to logic high, this pin outputs the signal defined as SD in the I ² S bus specification. See the Reading Data Using the I ² S Interface section for details.
55	SCO	Serial Clock Out. This clock signal is derived from the internal ICLK signal. The frequency of SCO is equal to either ICLK or ICLK/2, depending on the state of the $\overline{\text{CDIV}}$ and SCR pins (see the AD7763 Interface section). When the I ² S pin is logic high, this pin outputs the signal defined as SCK by the I ² S bus specification. See the Reading Data Using the I ² S Interface section.
56	$\overline{\text{FSO}}$	Frame Sync Out. This signal frames the serial data output and is 32 SCO periods wide. The exception to the framing behavior of $\overline{\text{FSO}}$ occurs in decimate × 32 mode, where, for certain combinations of $\overline{\text{CDIV}}$ and SCR, the $\overline{\text{FSO}}$ signal is constantly logic low. See the Reading Data Using the SPI Interface section. When the I ² S pin is set to logic high, this pin outputs the signal defined as WS in the I ² S bus specification. See the Reading Data Using the I ² S Interface section.
58	$\overline{\text{CDIV}}$	Clock Divider. This pin is used to select the ratio of MCLK to ICLK. See the AD7763 Interface section.
60	SCR	Serial Clock Rate. This pin and the $\overline{\text{CDIV}}$ pin program the SCO frequency (see Table 7).
61	I ² S	I ² S Select. A Logic 1 on this pin changes the serial data-out mode from SPI to I ² S. The SDO pin outputs as the SD signal, the SCO pin outputs the SCK signal, and the $\overline{\text{FSO}}$ pin outputs the WS signal. When writing to the AD7763, the I ² S pin is set to logic low and the SPI interface is used. See the Reading Data Using the I ² S Interface section for further details.
	EPAD	Exposed Pad. Connect the exposed pad to AGNDx with six to eight vias.

TERMINOLOGY

Signal-to-Noise Ratio (SNR)

The ratio of the rms value of the actual input signal to the rms sum of all other spectral components below the Nyquist frequency, excluding harmonics and dc. The value for SNR is expressed in decibels.

Total Harmonic Distortion (THD)

The ratio of the rms sum of harmonics to the fundamental. For the [AD7763](#), it is defined as

$$THD(\text{dB}) = 20 \log \frac{\sqrt{V_2^2 + V_3^2 + V_4^2 + V_5^2 + V_6^2}}{V_1}$$

where:

V_1 is the rms amplitude of the fundamental.

V_2 , V_3 , V_4 , V_5 , and V_6 are the rms amplitudes of the second to the sixth harmonic.

Nonharmonic Spurious-Free Dynamic Range (SFDR)

The ratio of the rms signal amplitude to the rms value of the peak spurious spectral component, excluding harmonics.

Dynamic Range

The ratio of the rms value of the full scale to the rms noise measured with the inputs shorted together. The value for dynamic range is expressed in decibels.

Integral Nonlinearity (INL)

The maximum deviation from a straight line passing through the endpoints of the ADC transfer function.

Differential Nonlinearity (DNL)

The difference between the measured and the ideal 1 LSB change between any two adjacent codes in the ADC.

Zero Error

The difference between the ideal midscale input voltage (0 V) and the actual voltage producing the midscale output code.

Zero Error Drift

The change in the actual zero error value due to a temperature change of 1°C. It is expressed as a percentage of full scale at room temperature.

Gain Error

The first transition (from 100...000 to 100...001) should occur for an analog voltage 1/2 LSB above the nominal negative full scale. The last transition (from 011...110 to 011...111) should occur for an analog voltage 1 1/2 LSB below the nominal full scale. The gain error is the deviation of the difference between the actual level of the last transition and the actual level of the first transition, from the difference between the ideal levels.

Gain Error Drift

The change in the actual gain error value due to a temperature change of 1°C. It is expressed as a percentage of full scale at room temperature.

TYPICAL PERFORMANCE CHARACTERISTICS

$AV_{DD1} = DV_{DD} = V_{DRIVE} = 2.5\text{ V}$, $AV_{DD2} = AV_{DD3} = AV_{DD4} = 5\text{ V}$, $V_{REF} = 4.096\text{ V}$, $T_A = 25^\circ\text{C}$, normal mode, unless otherwise noted. All FFTs are generated from 65,536 samples using a 7-term Blackman-Harris window.

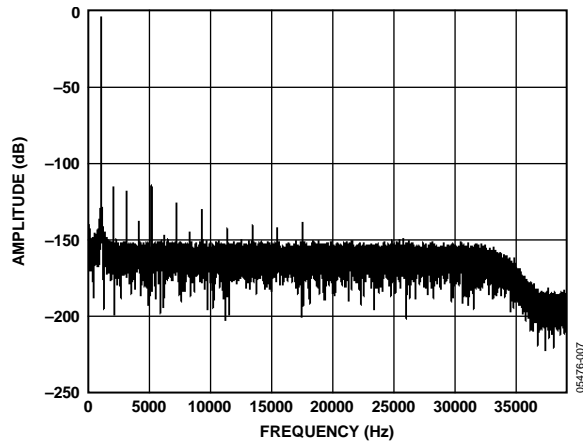

Figure 6. Normal Mode FFT, 1 kHz, -0.5 dB Input Tone, $256\times$ Decimation

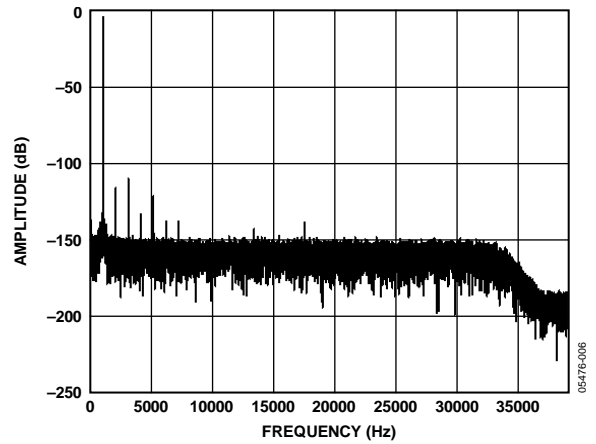

Figure 9. Low Power FFT, 1 kHz, -0.5 dB Input Tone, $256\times$ Decimation

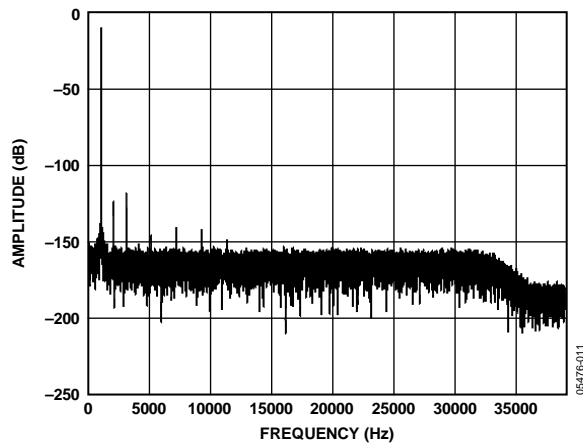

Figure 7. Normal Mode FFT, 1 kHz, -0.6 dB Input Tone, $256\times$ Decimation

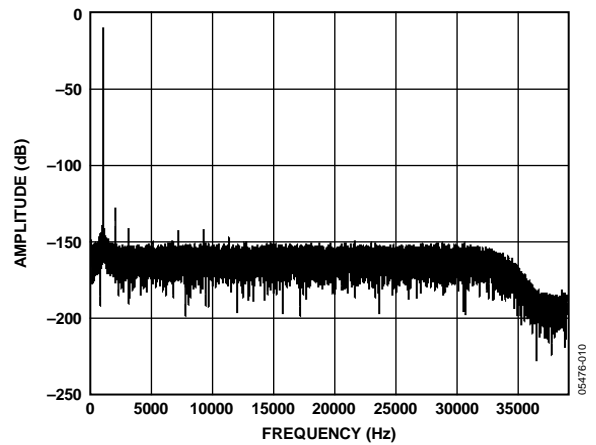

Figure 10. Low Power FFT, 1 kHz, -6 dB Input Tone, $256\times$ Decimation

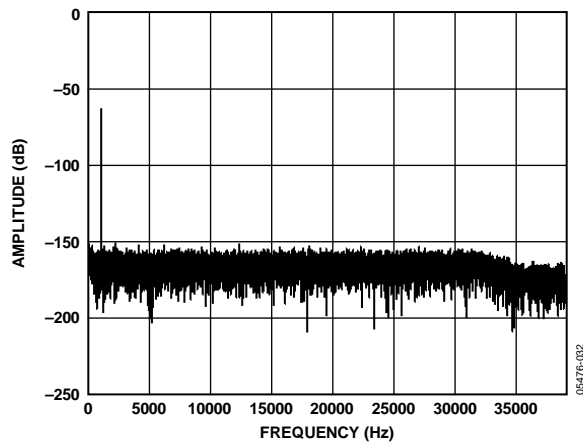

Figure 8. Normal Mode FFT, 1 kHz, -60 dB Input Tone, $256\times$ Decimation

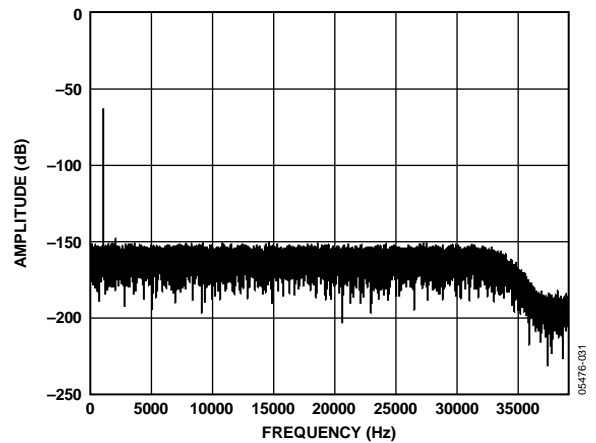

Figure 11. Low Power FFT, 1 kHz, -60 dB Input Tone, $256\times$ Decimation

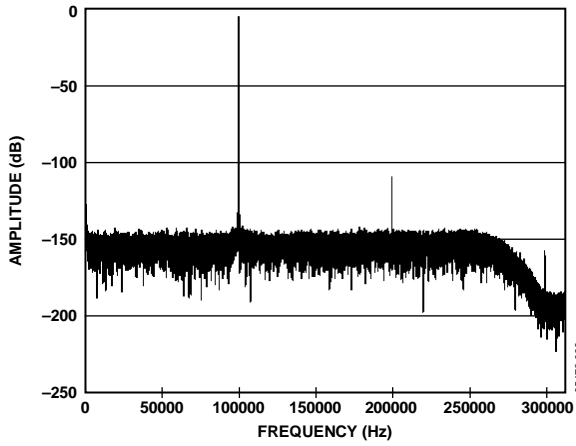

Figure 12. Normal Mode FFT, 100 kHz, -0.5 dB Input Tone, 32x Decimation

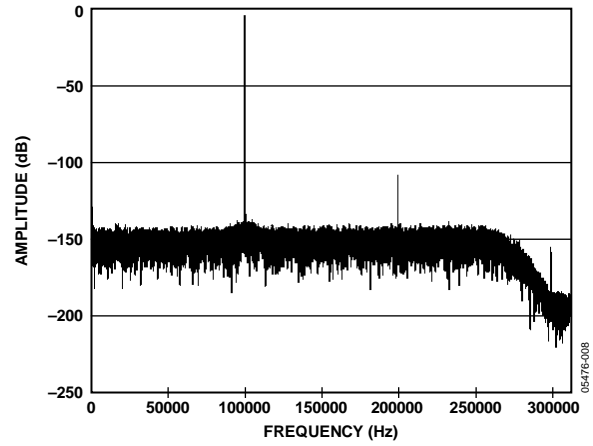

Figure 15. Low Power FFT, 100 kHz, -0.5 dB Input Tone, 32x Decimation

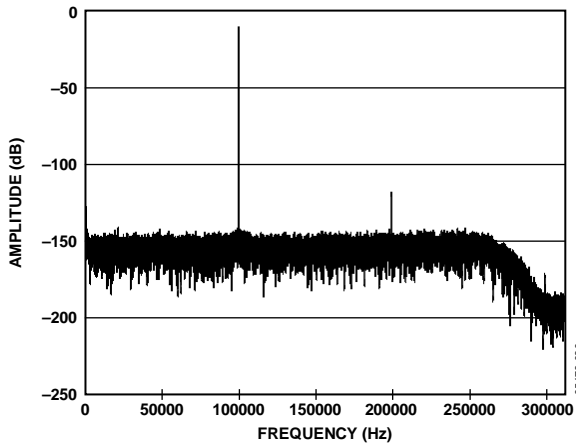

Figure 13. Normal Mode FFT, 100 kHz, -6 dB Input Tone, 32x Decimation

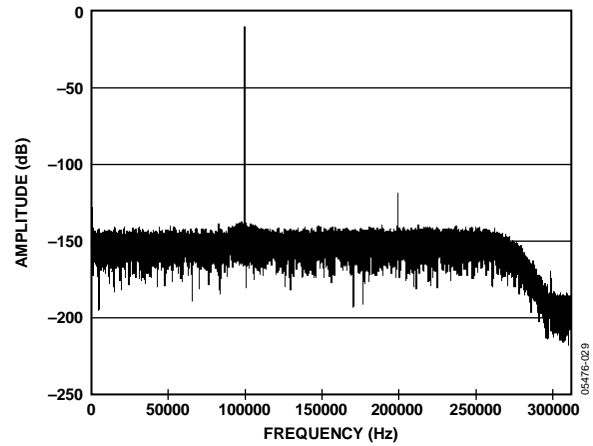

Figure 16. Low Power FFT, 100 kHz, -6 dB Input Tone, 32x Decimation

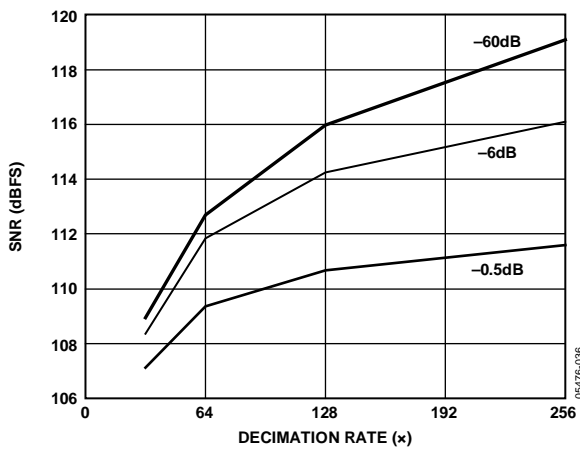

Figure 14. Normal Mode SNR vs. Decimation Rate, 1 kHz Input Tone

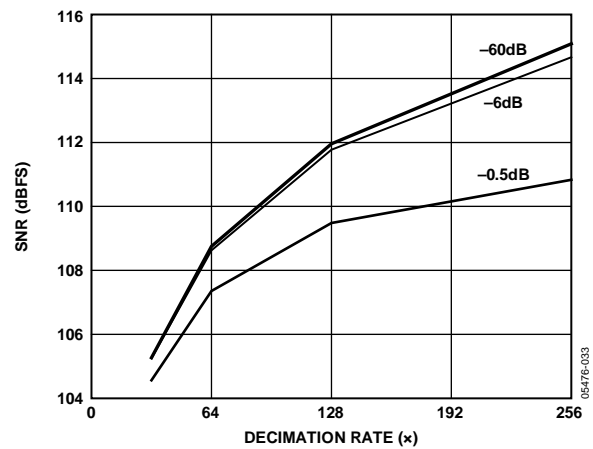

Figure 17. Low Power SNR vs. Decimation Rate, 1 kHz Input Tone

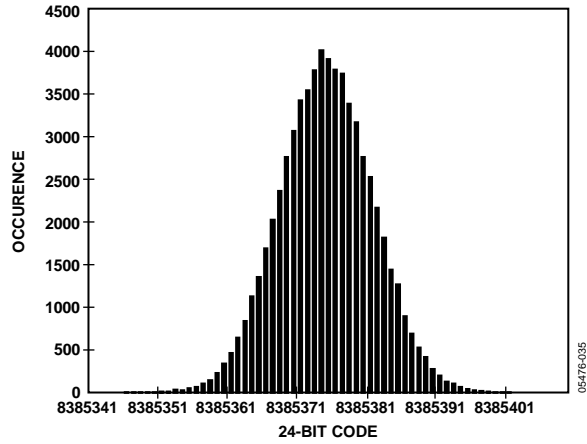

Figure 18. Normal Mode, 24-Bit Histogram, 256x Decimation

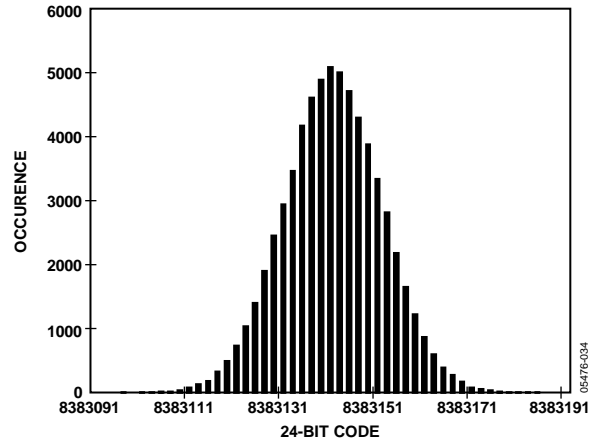

Figure 21. Low Power 24-Bit Histogram, 256x Decimation

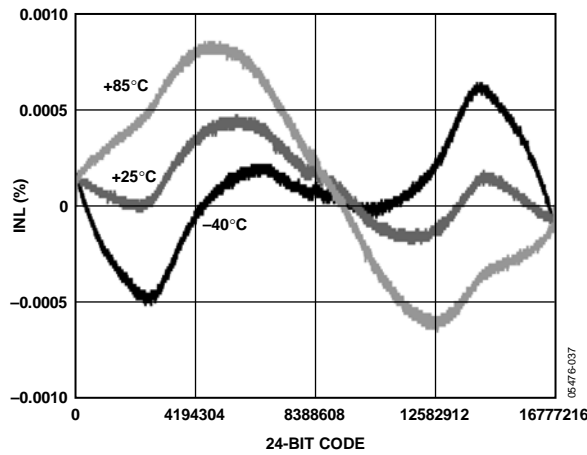

Figure 19. 24-Bit INL, Normal Power Mode

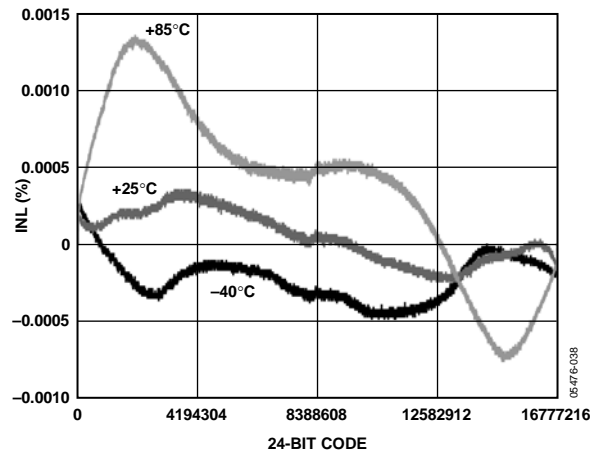

Figure 22. 24-Bit INL, Low Power Mode

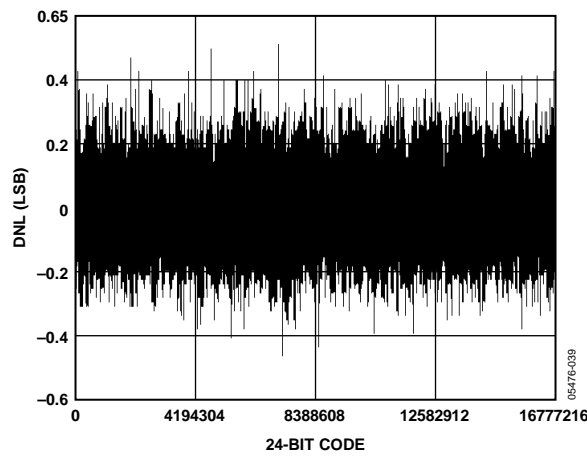

Figure 20. 24-Bit DNL

THEORY OF OPERATION

The AD7763 employs a Σ - Δ conversion technique to convert the analog input into an equivalent digital word. The modulator samples the input waveform and outputs an equivalent digital word to the digital filter at a rate equal to ICLK.

Due to the high oversampling rate, which spreads the quantization noise from 0 to f_{ICLK} , the noise energy contained in the band of interest is reduced (see Figure 23). To further reduce quantization noise, a high order modulator is employed to shape the noise spectrum; thus, most of the noise energy is shifted out of the band of interest (see Figure 24).

The digital filtering that follows the modulator removes the large out-of-band quantization noise (see Figure 25), while also reducing the data rate from f_{ICLK} at the input of the filter to $f_{\text{ICLK}}/32$ or less at the output of the filter, depending on the decimation rate used.

Digital filtering has certain advantages over analog filtering. It does not introduce significant noise or distortion and can be made perfectly linear phase.

The AD7763 employs three finite impulse response (FIR) filters in series. By using different combinations of decimation ratios and filter selection, data can be obtained from the AD7763 at four different data rates. The first filter receives data from the modulator at ICLK MHz, where it is decimated $\times 4$ to output data at (ICLK/4) MHz.

The second filter allows the decimation rate to be chosen from $8\times$ to $32\times$. The third filter has a fixed decimation rate of $2\times$, is user programmable, and has a default configuration (see the Programmable FIR Filter section). This filter can be bypassed.

Table 6 shows some characteristics of the default filter. The group delay of the filter is defined as the delay to the center of the impulse response and is equal to the computation plus filter delays. The delay until valid data is available (the DVALID status bit is set) is equal to $2\times$ the filter delay plus the computation delay.

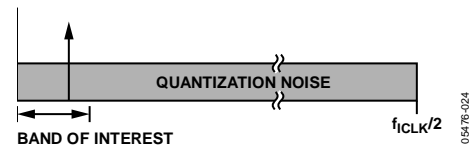

Figure 23. Σ - Δ ADC, Quantization Noise

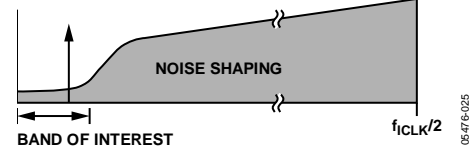

Figure 24. Σ - Δ ADC, Noise Shaping

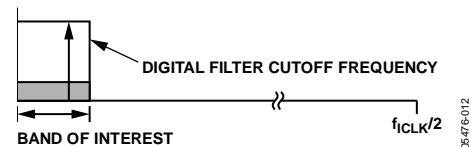

Figure 25. Σ - Δ ADC, Digital Filter Cutoff Frequency

Table 6. Configuration With Default Filter

ICLK Frequency	Filter 1	Filter 2	Filter 3	Data State	Computation Delay	Filter Delay	Pass Band Bandwidth	Output Data Rate (ODR)
20 MHz	4 \times	4 \times	2 \times	Fully filtered	1.775 μ s	44.4 μ s	250 kHz	625 kHz
20 MHz	4 \times	8 \times	Bypassed	Partially filtered	2.6 μ s	10.8 μ s	140.625 kHz	625 kHz
20 MHz	4 \times	8 \times	2 \times	Fully filtered	2.25 μ s	87.6 μ s	125 kHz	312.5 kHz
20 MHz	4 \times	16 \times	Bypassed	Partially filtered	4.175 μ s	20.4 μ s	70.3125 kHz	312.5 kHz
20 MHz	4 \times	16 \times	2 \times	Fully filtered	3.1 μ s	174 μ s	62.5 kHz	156.25 kHz
20 MHz	4 \times	32 \times	Bypassed	Partially filtered	7.325 μ s	39.6 μ s	35.156 kHz	156.25 kHz
20 MHz	4 \times	32 \times	2 \times	Fully filtered	4.65 μ s	346.8 μ s	31.25 kHz	78.125 kHz
12.288 MHz	4 \times	8 \times	2 \times	Fully filtered	3.66 μ s	142.6 μ s	76.8 kHz	192 kHz
12.288 MHz	4 \times	16 \times	2 \times	Fully filtered	5.05 μ s	283.2 μ s	38.4 kHz	96 kHz
12.288 MHz	4 \times	32 \times	Bypassed	Partially filtered	11.92 μ s	64.45 μ s	21.6 kHz	96 kHz
12.288 MHz	4 \times	32 \times	2 \times	Fully filtered	7.57 μ s	564.5 μ s	19.2 kHz	48 kHz

AD7763 INTERFACE

READING DATA USING THE SPI INTERFACE

The timing diagram in Figure 2 shows how the AD7763 transmits its conversion results using the SPI-compatible serial interface.

The data being read from the AD7763 is clocked out using the serial clock output, SCO. The SCO frequency is dependent on the state of the serial clock output rate pin, SCR, and the clock divider mode chosen by the state of the clock divider pin, $\overline{\text{CDIV}}$ (see the Clocking the AD7763 section). Table 7 shows both the SCO frequency and the ICLK frequency for the AD7763, resulting from the states of both the $\overline{\text{CDIV}}$ and SCR pins.

Table 7. SCO Frequency

Clock Divide Mode	$\overline{\text{CDIV}}$	SCR	SCO Frequency	ICLK Frequency
Divide by 1	1	0	MCLK	MCLK
		1	MCLK	MCLK
Divide by 2	0	0	MCLK/2	MCLK/2
		1	MCLK ¹	MCLK/2

¹ In decimate $\times 32$ mode, when $\overline{\text{CDIV}} = 0$ and SCR = 1, $\overline{\text{FSO}}$ pulses low for 32 SCO clock cycles, as shown in Figure 2. For all other combinations of $\overline{\text{CDIV}}$ and SCR in decimate $\times 32$ mode, $\overline{\text{FSO}}$ is continuously low.

An active low pulse of one SCO period on the data-ready output, $\overline{\text{DRDY}}$, indicates a new conversion result is available at the AD7763 serial data output, SDO.

Each bit of the new conversion result is clocked onto the SDO line on the rising SCO edge and is valid on the falling SCO edge (for SCP = 0). The conversion result spans 32 SCO clock cycles and consists of 24 data bits in twos complement form, followed by 7 status bits.

D6	D5	D4	D3	D2	D1	D0
ADR2	ADR1	ADR0	DVALID	OVR	LPWR	FILTER_OK

The conversion result output on the SDO line is framed by the frame synchronization output, $\overline{\text{FSO}}$, which is sent logic low for 32 SCO cycles following the rising edge of the $\overline{\text{DRDY}}$ signal. Note that the SDO line is in three-state for one clock cycle before the $\overline{\text{FSO}}$ signal returns to logic high, which means that only 31 actual data bits are output in each conversion.

The first three status bits, ADR[2:0], are the device address bits. The DVALID bit is asserted when the data being clocked out on the SDO line is valid. Table 19 contains descriptions of the other status bits: OVR, LPWR, and FILTER_OK.

There is an exception to the behavior of $\overline{\text{FSO}}$ when the AD7763 operates in decimate $\times 32$ mode (see Endnote 1 of Table 7). If SCR and $\overline{\text{CDIV}}$ are chosen so that the SCO frequency output has the capability to clock through only 32 SCO cycles before the MSB of the next conversion result is output, then $\overline{\text{FSO}}$ stays logic low continuously.

The AD7763 also features a serial data latch output, SDL, which outputs a pulse every 16 data bits. The SDL output offers an alternative framing signal for serial transfers, which require a framing signal more frequent than every 32 bits.

SYNCHRONIZATION

The SYNC input to the AD7763 provides a synchronization function that allows the user to begin gathering samples of the analog front-end input from a known point in time.

The SYNC function allows multiple AD7763s, operated from the same master clock and using the same SYNC signal, to be synchronized so that each ADC simultaneously updates its output register.

Using a common SYNC signal to all AD7763 devices in a system allows synchronization to occur. On the falling edge of the SYNC signal, the digital filter sequencer is reset to 0. The filter is held in reset state until a rising edge of the SCO senses SYNC high. Thus, to perform a synchronization of devices, a SYNC pulse of a minimum of 2.5 ICLK cycles in length can be applied, synchronous to the falling edge of SCO. On the first rising edge of SCO after SYNC goes logic high, the filter is taken out of reset, and the multiple parts gather input samples synchronously.

Following a SYNC, the digital filter needs time to settle before valid data can be read from the AD7763. The user knows there is valid data on the SDO line by checking the DVALID status bit (see D3 in the status bits listing) that is output with each conversion result. The time from the rising edge of SYNC until the DVALID bit is asserted is dependent on the filter configuration used. See the Theory of Operation section and the figures listed in Table 6 for details on calculating the time until DVALID is asserted.

SHARING THE SERIAL BUS

The AD7763 functionality allows up to eight devices to share the same serial bus, SDO, depending on the decimation rate that is chosen.

Table 8 details the maximum number of devices that can share the same SDO line for each decimation rate ($\times 32$, $\times 64$, $\times 128$, $\times 256$).

Table 8. Maximum Number of Devices Sharing SDO

	Decimation Rate				
	SCO (MHz)	$\times 32$	$\times 64$	$\times 128$	$\times 256$
Maximum Number of Devices Sharing SDO	40	2	4	8	8
	20	N/A	2	4	8

The Share Pins SH[2:0] of all the devices sharing the serial bus must be programmed for the correct number of devices that are sharing the serial bus. A binary value of $N - 1$ should be applied to the SH[2:0] bits, where N equals the number of devices in the chain. For example if there are 4 devices in the chain set SH[2:0] = 011.

Using the Address Pins ADR[2:0], all devices that share the serial bus are assigned binary addresses from 000 to 111 (depending on the number of devices in the share scheme). The address assigned to each device must not have a value greater than the number of devices sharing the serial bus. Thus, $ADR[2:0] \leq SH[2:0]$. This applies to all the devices that share the serial bus. Note also that each of the devices in the share scheme must have a different individual address.

For the device in the share scheme with an address of 000, the SDO line comes out of three-state on the first rising edge of SCO after the \overline{DRDY} pulse and returns to three-state 5.5 ns before the 31st SCO rising edge. For the next device sharing the serial bus, Address 001, the SDO line comes out of three-state on the 33rd SCO rising edge (that is, the first SCO rising edge of the next conversion output cycle). Thus, the SDO line goes into tri-state for one SCO cycle in between data being clocked onto SDO by two different devices that share the SDO line. This means that a bus contention issue is avoided. This pattern of behavior continues for the rest of the devices sharing the serial bus.

Each AD7763 device sharing the serial bus outputs its own \overline{FSO} signal.

Figure 26 shows an example of four devices sharing the same serial bus. All the devices in the share chain shown in Figure 26 operate in decimate $\times 64$ mode (selected by writing to Control Register 1—Address 0x001) and use a maximum SCO signal of 40 MHz (see the Clocking the AD7763 section).

The Share Pins SH[2:0] of all the devices shown in Figure 26 are set to 011, corresponding to the four devices that are in the share configuration. Each AD7763 is hardwired with a different binary address ranging from 000 to 011, using the Address Pins ADR[2:0].

The timing diagram for the share configuration shown in Figure 26 is detailed in Figure 4. Device A outputs its 32-bit conversion result on the SDO line during the first 32 SCO cycles (as per the format shown in the Reading Data Using the SPI Interface section). Device B then outputs its conversion result during the next 32 SCO cycles, and so on for Device C and Device D. Note the way in which the SDO line is three-stated, separating data from each of the devices sharing the serial bus. The provision of two framing signals, \overline{DRDY} and \overline{FSO} , ensures that the AD7763 offers flexible data output framing options, which are further enhanced by the availability of the SDL output. The user can select the framing output that best suits the application.

WRITING TO THE AD7763

Figure 3 shows the AD7763 write operation. The serial writing operation is synchronous to the SCO signal. The status of the frame sync input, \overline{FSI} , is checked on the falling edge of the SCO signal. If the \overline{FSI} line is low, then the first data is latched in on the next SCO falling edge.

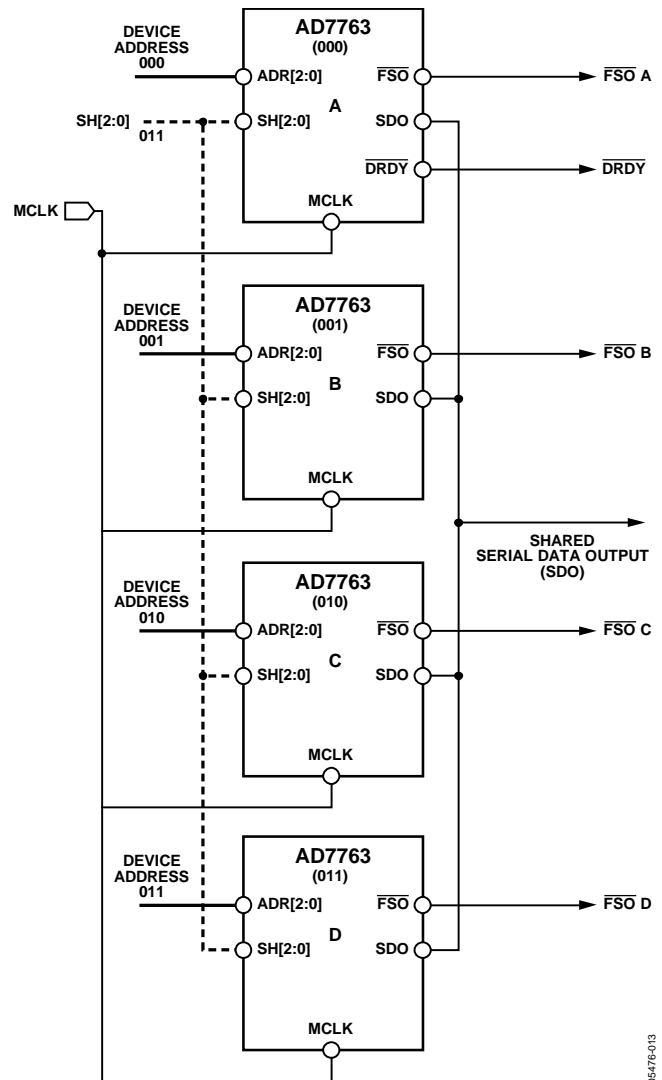

Figure 26. Four AD7763 Devices Sharing the Serial Bus

The active edge of the \overline{FSI} signal should be set to occur at a position when the SCO signal is high or low and which also allows setup and hold time from the SCO falling edge to be met. The width of the \overline{FSI} signal can be set to between 1 SCO period and 32 SCO periods wide. A second or subsequent \overline{FSI} falling edge, which occurs before 32 SCO periods have elapsed, is ignored.

Figure 3 also shows the format for the serial data written to the AD7763. A write operation requires 32 bits. The first 16 bits select the device and register address for which the data written is intended. The second 16 bits contain the data for the selected register. When using multiple devices that share the same serial bus,

all $\overline{\text{FSO}}$ and SDI pins can be tied together and each device written to individually by setting the appropriate address bits in the serial 32-bit word. The exception to this is when all devices can be written to at the same time by setting the ALL bit to logic high.

Thus, if this bit is set to logic high, every device on the serial bus accepts the data written, regardless of the address bits. This feature is particularly attractive if, for example, four devices are being configured with the same user-defined filter. Instead of having to download the filter configuration four times, only one write is required. See the Downloading a User-Defined Filter section for further details.

Writing to AD7763 is allowed at any time, even while reading a conversion result. Note that after writing to the devices, valid data is not output until after the settling time for the filter has elapsed. The DVALID status bit is asserted at this point to indicate that the filter has settled and that valid data is available at the output.

READING STATUS AND OTHER REGISTERS

The AD7763 features a number of programmable registers. To read back the contents of these registers or the status register, the user must first write to the control register of the device, setting a bit corresponding to the register to be read. The next read operation then outputs the contents of the selected register instead of a conversion result.

To ensure that the next read cycle contains the contents of the register that has been written to, the write operation to the register in question must be completed a minimum of $8 \times t_{\text{SCO}}$ before the falling edge of $\overline{\text{DRDY}}$, which indicates the start of the next read cycle.

More information on the relevant bits in the control register is provided in the Registers section.

READING DATA USING THE I²S INTERFACE

The AD7763 has the capability of operating using an I²S interface. The interface is functional only for the output of stereo data and does not apply to writing to control registers, programming coefficients for the digital filter, or the reading of any information contained in the AD7763 onboard registers. All of these operations must be undertaken using the normal serial interface.

The I²S interface operates using two AD7763 devices. The pins shown in Table 9 are used as the output pins for the SCK (serial clock), SD (serial data), and WS (word select) signals for the I²S interface.

Table 9.

SPI Pins	I ² S Signals
FSO	WS
SDO	SD
SCO	SCK

To enable the I²S interface, the I²S pin is set to logic high. The Share Pins SH[2:0] of both AD7763 devices that use the I²S interface are set to 001. The Address Pins ADR[2:0] of the two devices must also be set to 000 and 001, respectively.

The WS and SCK signals that are used for the interface can be taken from either AD7763 device. Note that the device that is assigned Address 000 is defined as the left channel, and its data is output on the SD line when WS is logic low.

The WS and SCK signals can be taken from the appropriate pins on either of the AD7763 devices using the I²S interface. The SD pins of both devices must be connected together, as shown in Figure 27.

Data is clocked out on the SD line in accordance with Figure 28. Because Device A is assigned Address 000, it is defined as the left channel. The 32-bit conversion result from the left channel is clocked out when WS is logic low, with the MSB being clocked out first. Each 32-bit result consists of 24 data bits in twos complement format, followed by eight status bits, as shown in the following bit map.

D7	D6	D5	D4	D3	D2	D1	D0
DVALID	OVR	UFILTER	LPWR	FILTER_OK	ADRO	0	Three-State

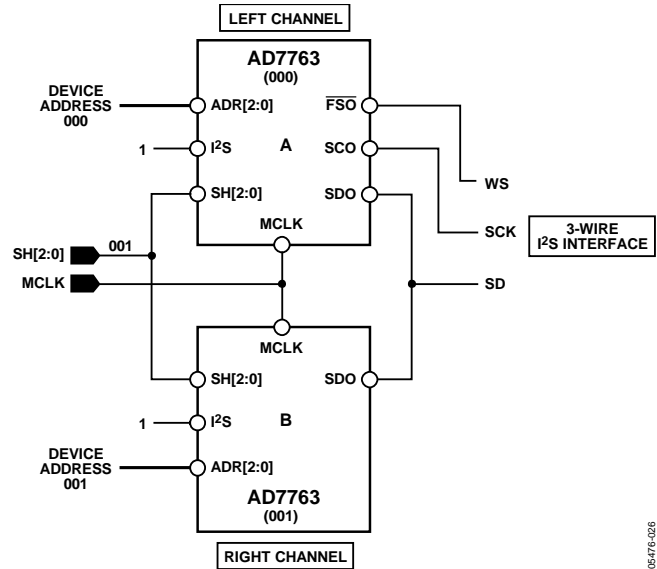

Figure 27. Two AD7763 Devices Operating Using the I²S Interface

Conversion results from Device B, assigned Address 001, are clocked out on the SD line when WS is logic high. The SD line goes into three-state on the falling edge of the 32nd SCK after the falling edge of WS (left channel data) and also on the falling edge of the 32nd SCK after the rising edge of WS (right channel data). This permits swapping of the SD bus between the left and right channel devices without contention.

In decimate × 32 mode the I²S interface is operational only when $\overline{CDIV} = 0$ and $SCR = 1$. The interface operates for all combinations of SCR and \overline{CDIV} in all other modes of decimation.

The \overline{DRDY} pulse still operates as in the normal serial SPI-type interface, pulsing low immediately prior to the falling edge of WS but having no meaning in the I²S interface specification.

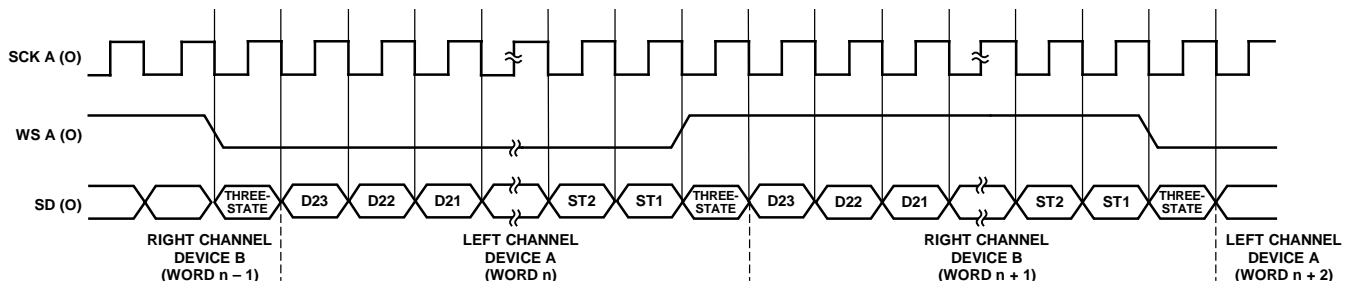

Figure 28. Timing Diagram for I²S Interface

CLOCKING THE AD7763

The AD7763 requires an external, low jitter clock source. This signal is applied to the MCLK pin, and the MCLKGND pin is used to sense the ground from the clock source. An internal clock signal (ICLK) is derived from the MCLK input signal. The ICLK controls the internal operations of the AD7763. The maximum ICLK frequency is 20 MHz, but due to an internal clock divider, a range of MCLK frequencies can be used. There are two ways to generate the ICLK:

$$ICLK = MCLK (\overline{CDIV} = 1)$$

$$ICLK = MCLK/2 (\overline{CDIV} = 0)$$

This option is pin selectable (Pin 58). On power-up, the default is $ICLK = MCLK/2$ to ensure that the part can handle the maximum MCLK frequency of 40 MHz. For output data rates equal to those used in audio systems, a 12.288 MHz ICLK frequency can be used. As shown in Table 6, output data rates of 192 kHz, 96 kHz, and 48 kHz are achievable with this ICLK frequency. As mentioned previously, this ICLK frequency can be derived from different MCLK frequencies.

The MCLK jitter requirements depend on a number of factors and are determined by

$$t_{j(rms)} = \frac{\sqrt{OSR}}{2 \times \pi \times f_{IN} \times 10^{\frac{SNR(dB)}{20}}}$$

Where:

$$OSR = \text{oversampling ratio} = \frac{f_{ICLK}}{ODR}$$

f_{IN} = maximum input frequency.

$SNR(dB)$ = target SNR.

EXAMPLE 1

This example is taken from Table 6, where:

$$ODR = 625 \text{ kHz.}$$

$$f_{ICLK} = 20 \text{ MHz.}$$

$$f_{IN} (\text{maximum}) = 250 \text{ kHz.}$$

$$SNR = 108 \text{ dB.}$$

$$t_{j(rms)} = \frac{\sqrt{32}}{2 \times \pi \times 250 \times 10^3 \times 10^6} = 3.6 \text{ ps}$$

This is the maximum allowable clock jitter for a full-scale, 250 kHz input tone with the given ICLK and output data rate.

EXAMPLE 2

Following is a second example from Table 6, where:

$$ODR = 48 \text{ kHz.}$$

$$f_{ICLK} = 12.288 \text{ MHz.}$$

$$f_{IN} (\text{maximum}) = 19.2 \text{ kHz.}$$

$$SNR = 120 \text{ dB.}$$

$$t_{j(rms)} = \frac{\sqrt{256}}{2 \times \pi \times 19.2 \times 10^3 \times 10^6} = 133 \text{ ps}$$

The input amplitude also has an effect on these jitter figures. If, for example, the input level is 3 dB below full scale, the allowable jitter is increased by a factor of $\sqrt{2}$, increasing the first example to 2.53 ps rms. This happens when the maximum slew rate is decreased by a reduction in amplitude. Figure 29 and Figure 30 illustrate this point, showing the maximum slew rate of a sine wave of the same frequency but with different amplitudes.

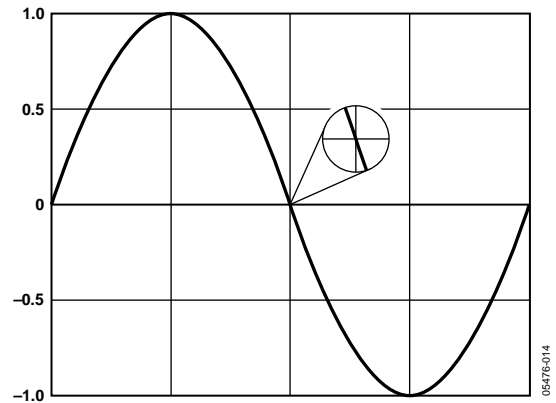

Figure 29. Maximum Slew Rate of Sine Wave with Amplitude of 2 V p-p

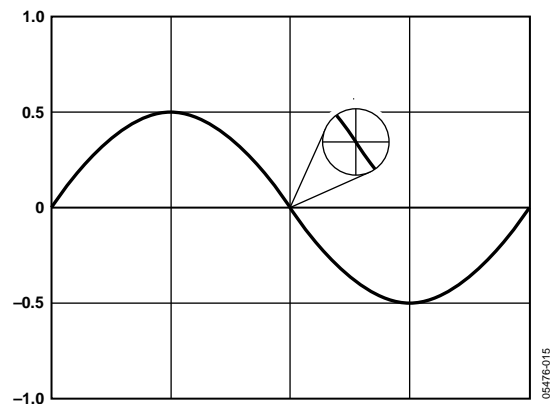

Figure 30. Maximum Slew Rate of Same Frequency Sine Wave with Amplitude of 1 V p-p

DRIVING THE AD7763

The AD7763 has an on-chip differential amplifier that operates with a supply voltage (AV_{DD3}) from 3.15 V to 5.25 V. For a 4.096 V reference, the supply voltage must be 5 V.

To achieve the specified performance in normal mode, the differential amplifier should be configured as a first-order antialias filter, as shown in Figure 31. Any additional filtering should be carried out in previous stages using low noise, high performance op amps, such as the AD8021.

Suitable component values for the first-order filter are shown in Table 10. The values in Table 10 yield a 10 dB attenuation at the first alias point of 19 MHz.

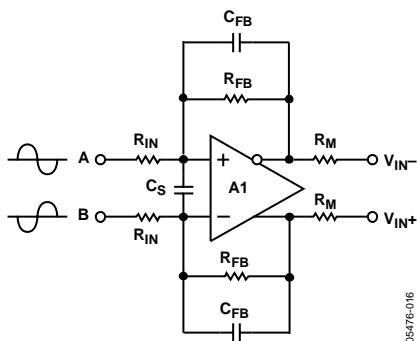

Figure 31. Differential Amplifier Configuration

Table 10. Normal Mode Component Values

V_{REF}	R_{IN}	R_{FB}	R_M	C_S	C_{FB}
4.096 V	1 k Ω	655 Ω	18 Ω	5.6 pF	33 pF

Figure 32 shows the signal conditioning that occurs using the circuit in Figure 18 with a ± 2.5 V input signal biased around ground and having the component values and conditions in Table 10.

The differential amplifier always biases the output signal to sit on the optimum common mode of $V_{REF}/2$, in this case, 2.048 V. The signal is also scaled to give the maximum allowable voltage swing with this reference value. This is calculated as 80% of V_{REF} ; that is, 0.8×4.096 V \approx 3.275 V p-p on each input.

To obtain maximum performance from the AD7763, it is advisable to drive the ADC with differential signals. Figure 33 shows how a bipolar, single-ended signal biased around ground can drive the AD7763 with the use of an external op amp, such as the AD8021.

With a 4.096 V reference, a 5 V supply must be provided to the reference buffer (AV_{DD4}). With a 2.5 V reference, a 3.3 V supply must be provided to AV_{DD4} .

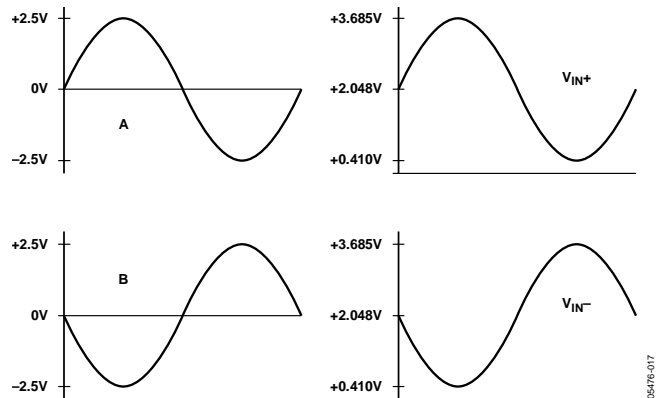

Figure 32. Differential Amplifier Signal Conditioning

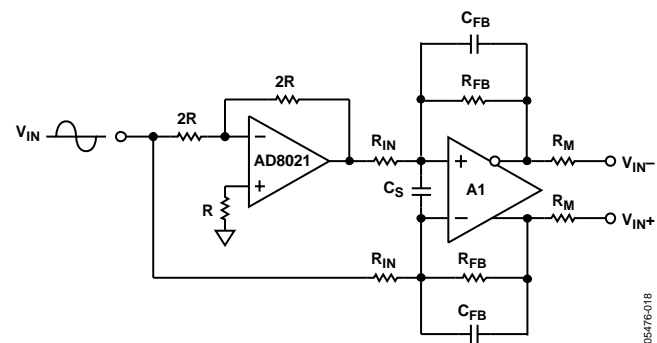

Figure 33. Single-Ended-to-Differential Conversion

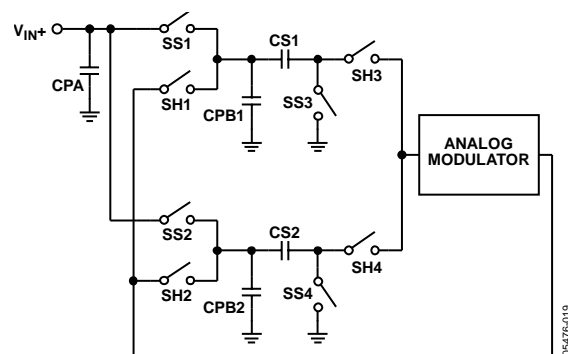

Figure 34. Equivalent Input Circuit

The AD7763 employs a double sampling front end, as shown in Figure 34. For simplicity, only the equivalent input circuit for V_{IN+} is shown. The equivalent input circuitry for V_{IN-} is the same.

Sampling Switch SS1 and Sampling Switch SS3 are driven by ICLK, whereas Sampling Switch SS2 and Sampling Switch SS4 are driven by ICLK. When ICLK is high, the analog input voltage is connected to CS1. On the falling edge of ICLK, the SS1 and SS3 switches open, and the analog input is sampled on CS1. Similarly, when ICLK is low, the analog input voltage is connected to CS2. On the rising edge of ICLK, the SS2 and SS4 switches open, and the analog input is sampled on CS2.

Capacitor CPA, Capacitor CPB1, and Capacitor CPB2 represent parasitic capacitances that include the junction capacitances associated with the MOS switches.

Table 11. Equivalent Component Values

Mode	CS1	CS2	CPA	CPB1/CPB2
Normal	51 pF	51 pF	12 pF	20 pF
Low Power	13 pF	13 pF	12 pF	5 pF

USING THE AD7763

Following is the recommended sequence for powering up and using the AD7763.

1. Apply power.
2. Start clock oscillator, applying MCLK.
3. Take $\overline{\text{RESET}}$ low for a minimum of 1 MCLK cycle.
4. Wait a minimum of 2 MCLK cycles after $\overline{\text{RESET}}$ has been released.
5. Write to Control Register 2 to power up the ADC and the differential amplifier, as required.
6. Write to Control Register 1 to set up the output data rate.
7. In circumstances where multiple parts are being synchronized, a SYNC pulse must be applied to the parts; otherwise, no $\overline{\text{SYNC}}$ pulse is required.

The following are conditions for applying the $\overline{\text{SYNC}}$ pulse:

- The issuing of a $\overline{\text{SYNC}}$ pulse to the part must not coincide with a write to the part.
- The $\overline{\text{SYNC}}$ pulse should be applied a minimum of 2.5 ICLK cycles after the FSI signal for the previous write to the part has returned to logic high.
- Ensure that the $\overline{\text{SYNC}}$ pulse is taken low for a minimum of 2.5 ICLK cycles.

Data can now be read from the part using the default filter, offset, gain, and overrange threshold values. The conversion data read is not valid, however, until the settling time of the filter has passed. When this has occurred, the DVALID bit read is set, indicating that the data is indeed valid.

The user can then download a user-defined filter, if required (see Downloading a User-Defined Filter). Values for gain, offset, and overrange threshold registers can also be written or read at this stage.

BIAS RESISTOR SELECTION

The AD7763 requires a resistor to be connected between the R_{BIAS} pin and AGND. The value for this resistor is dependent on the reference voltage being applied to the device. The resistor value should be selected to give a current of 25 μA through the resistor to ground. For a 2.5 V reference voltage, the correct resistor value is 100 k Ω ; for a 4.096 V reference voltage, the correct resistor value is 160 k Ω .

DECOUPLING AND LAYOUT RECOMMENDATIONS

Due to the high performance nature of the [AD7763](#), correct decoupling and layout techniques are required to obtain the performance as stated within this data sheet. Figure 35 shows a simplified connection diagram for the [AD7763](#).

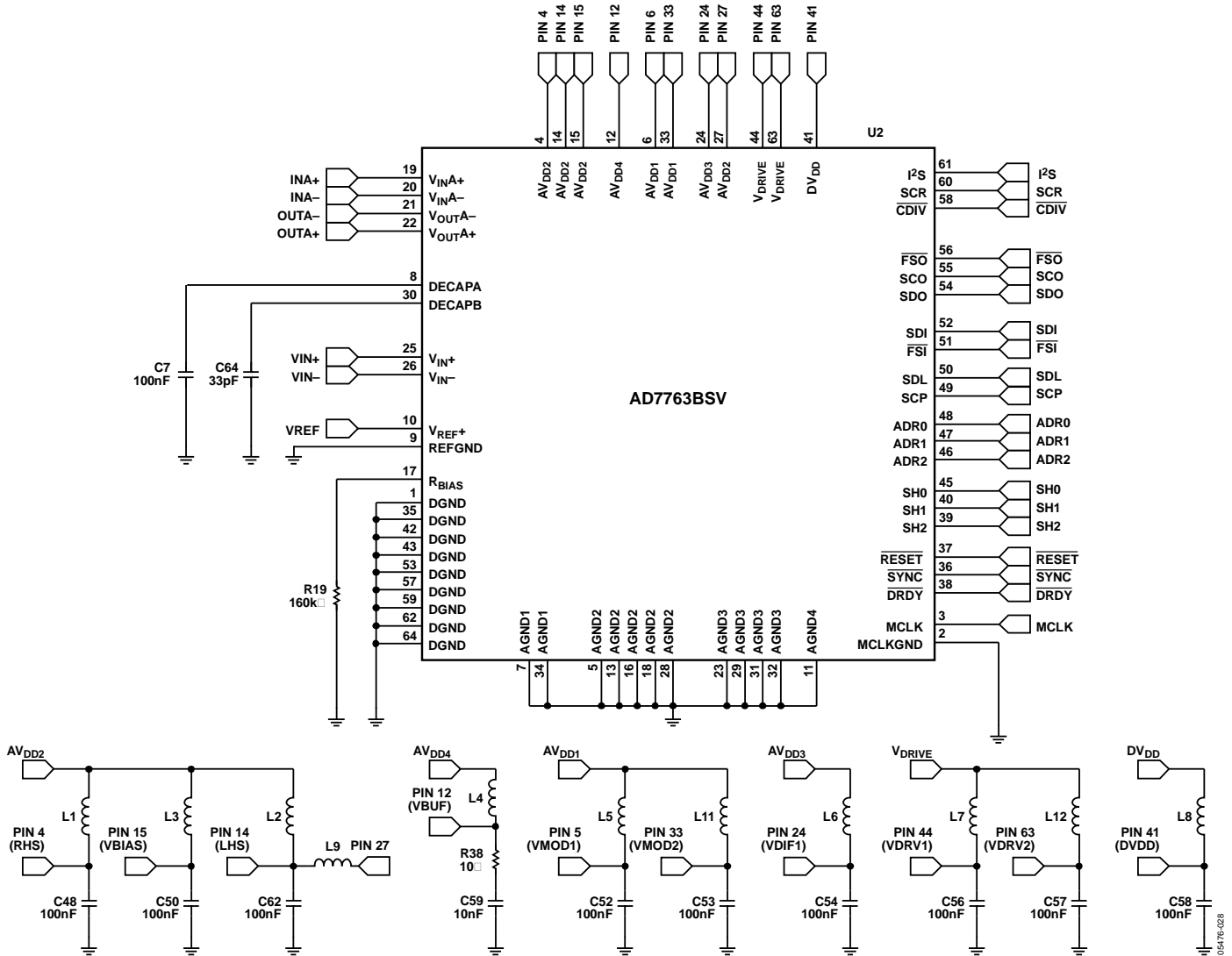

Figure 35. Simplified Connection Diagram

SUPPLY DECOUPLING

Every supply pin must be connected to the appropriate supply via a ferrite bead and decoupled to the correct ground pin with a 100 nF, 0603 case size, X7R dielectric capacitor. There are two exceptions

- Pin 12 (AV_{DD4}) must have a 10 Ω resistor inserted between the pin and a 10 nF decoupling capacitor.
- Pin 27 (AV_{DD2}) does not require a separate decoupling capacitor or a direct connection to the supply; instead, it is connected to Pin 14 via an 8.2 nH inductor.

The ferrite beads that are used to connect each supply pin to the appropriate power supply should have a characteristic impedance of 600 Ω to 1 M Ω at frequencies around 100 MHz, a dc impedance of 1 Ω or less, and a rated current of 200 mA.

ADDITIONAL DECOUPLING

There are two other decoupling pins on the AD7763: Pin 8 (DECAPA) and Pin 30 (DECAPB). Pin 8 should be decoupled with a 100 nF capacitor, and Pin 30 requires a 33 pF capacitor.

REFERENCE VOLTAGE FILTERING

A low noise reference source, such as the ADR431 (2.5 V) or ADR434 (4.096 V), is suitable for use with the AD7763. The reference voltage supplied to the AD7763 should be decoupled and filtered, as shown in Figure 36.

The recommended scheme for the reference voltage supply is a 100 Ω series resistor connected to a 100 μ F tantalum capacitor, followed by a series resistor of 10 Ω , and finally, a 10 nF decoupling capacitor very close to the V_{REF} pin.

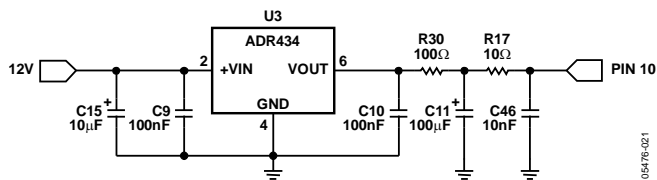

Figure 36. Reference Connection

DIFFERENTIAL AMPLIFIER COMPONENTS

The correct components for use around the on-chip differential amplifier are shown in Table 10. Matching the components on both sides of the differential amplifier is important to minimize distortion of the signal applied to the amplifier. A tolerance of 0.1% or better is required for these components. Symmetrical routing of the tracks on both sides of the differential amplifier also assists in achieving stated performance.

EXPOSED PADDLE

The AD7763 64-lead TQFP_EP employs a 6 mm \times 6 mm exposed paddle (see Figure 39). The paddle reduces the thermal resistance of the package by providing a path of low thermal resistance to the PCB and, in turn, increases the heat transfer efficiency from the AD7763 package. Soldering the exposed paddle to the AGND plane of the PCB is fundamental in creating the conditions that allow the AD7763 package to perform to the highest specifications possible.

LAYOUT CONSIDERATIONS

While using the correct components is essential to achieve optimum performance, the correct layout is just as important. The *Design Tools* section of the AD7763 product page on the Analog Devices website contains the Gerber files for the AD7763 evaluation board. These files should be used as a reference when designing any system using the AD7763.

The location and orientation of some of the components mentioned in previous sections are critical, and particular attention must be paid to the components that are located close to the AD7763. Locating these components farther away from the devices can have a direct impact on the maximum performance achievable.

The use of ground planes should also be carefully considered. To ensure that the return currents through the decoupling capacitors are flowing to the correct ground pin, the ground side of the capacitors should be as close as possible to the ground pin associated with that supply. A ground plane should not be relied upon as the sole return path for decoupling capacitors, because the return current path using ground planes is not easily predicted.

PROGRAMMABLE FIR FILTER

As discussed in the Theory of Operation section, the third FIR filter on the AD7763 can be programmed by the user. The default coefficients that are loaded on reset are shown in Table 12. This gives the frequency response shown in Figure 37. The frequencies shown in Figure 37 scale directly with the output data rate.

Table 12. Default Filter Coefficients

#	Decimal Value	Hex Value	#	Decimal Value	Hex Value
0	+53656736	332BCA0	24	+700847	AB1AF
1	+25142688	17FA5A0	25	-70922	401150A
2	-4497814	444A196	26	-583959	408E917
3	-11935847	4B62067	27	-175934	402AF3E
4	-1313841	4140C31	28	+388667	5EE3B
5	+6976334	6A734E	29	+294000	47C70
6	+3268059	31DDDB	30	-183250	402CBD2
7	-3794610	439E6B2	31	-302597	4049E05
8	-3747402	4392E4A	32	+16034	3EA2
9	+1509849	1709D9	33	+238315	3A2EB
10	+3428088	344EF8	34	+88266	158CA
11	+80255	1397F	35	-143205	4022F65
12	-2672124	428C5FC	36	-128919	401F797
13	-1056628	4101F74	37	+51794	CA52
14	+1741563	1A92FB	38	+121875	1DC13
15	+1502200	16EBF8	39	+16426	402A
16	-835960	40CC178	40	-90524	401619C
17	-1528400	4175250	41	-63899	400F99B
18	+93626	16DBA	42	+45234	B0B2
19	+1269502	135EFE	43	+114720	1C020
20	+411245	6466D	44	+102357	18FD5
21	-864038	40D2F26	45	+52669	CDBD
22	-664622	40A242E	46	+15559	3CC7
23	+434489	6A139	47	+1963	7AB

The default filter should be sufficient for most applications. It is a standard brick wall filter with a symmetrical impulse response. The default filter has a length of 96 taps and is nonaliasing, with 120 dB of attenuation at Nyquist. This filter not only performs signal antialiasing but also suppresses out-of-band quantization noise produced by the analog-to-digital conversion process. Any significant relaxation in the stop-band attenuation or transition bandwidth relative to the default filter can result in failure to meet the SNR specifications.

To create a user-defined filter, note the following:

- The filter must be even, symmetrical FIR.
- The coefficients are 27 bits in length. All coefficients are in sign-and-magnitude format. The sign bit coded as positive = 0 is followed by 26 magnitude bits.
- The filter length must be between 12 taps and 96 taps in steps of 12.
- Because the filter is symmetrical, the number of coefficients that must be downloaded is half the filter length. The default filter coefficients are an example of this, with only 48 coefficients listed for a 96-tap filter.
- Coefficients are written from the center of impulse response (adjacent to the point of symmetry) outward.
- The coefficients are scaled so that the in-band gain of the filter is equal to 134217726, with the coefficients rounded to the nearest integer. For a low-pass filter, this is the equivalent of having the coefficients sum arithmetically (including sign) to +67108863 (0x3FFFFFF) positive value over the half-impulse-response coefficient set (maximum 48 coefficients). Any deviation from this results in the introduction of a gain error.

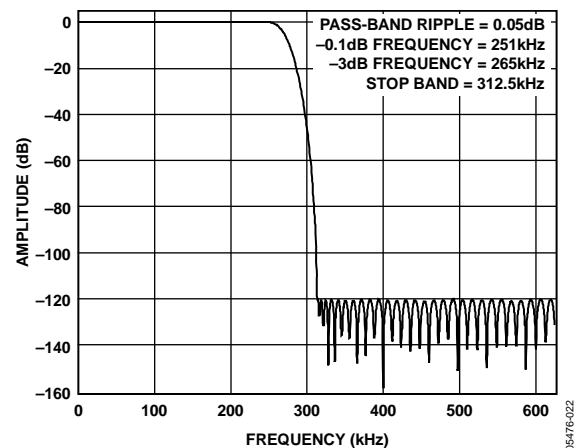

Figure 37. Default Filter Frequency Response (625 kHz ODR)

To download a user-defined filter, see the Downloading a User-Defined Filter section.

DOWNLOADING A USER-DEFINED FILTER

As discussed in the Programmable FIR Filter section, each of the filter coefficients is 27 bits in length: one sign bit and 26 magnitude bits. To download coefficients for a user-specific FIR filter, a 32-bit word is written to the [AD7763](#) for each coefficient.

D31	D30	D29	D28	D27	D26	D[25:0]
ALL	ADR2	ADR1	ADR0	0	Sign	Magnitude

When a user writes coefficients to one device, the address of that particular device (as assigned by the ADR[2:0] pins) must be specified in the bits labeled ADR[2:0].

In a configuration where more than one device shares the same SDI line, setting the ALL bit to logic high and leaving Address Bits ADR[2:0] logic low enables the user to write each coefficient to all devices simultaneously.

To ensure that a filter is downloaded correctly, a checksum must be generated and downloaded following the download of the final coefficient. The checksum is a 16-bit word generated by splitting each 32-bit word into 4 bytes and summing all bytes from all coefficients up to a maximum of 192 bytes (maximum number of coefficients = 48 bytes × 4 bytes written for each coefficient).

The checksum is written to the device in the form of a 32-bit word in the following format:

D31	D30	D29	D28	D[27:16]	D[15:0]
ALL	ADR2	ADR1	ADR0	0	Checksum

Note that when writing the checksum, the addressing requirements are as before, and Bit 27 to Bit 16 are all set to 0.

The same checksum is generated internally in the [AD7763](#) and compared with the checksum downloaded. The DL_OK bit in the status register is set if these two checksums agree.

To download a user-defined filter:

1. Write to Control Register 1, setting the DL Filt bit. The correct Filter Length Bits FLEN[3:0] correspond to the length of the filter about to be downloaded (see Table 13) and the correct decimation rate.
2. Write the 32-bit word (as per format specified). The first coefficient to be written must be the one adjacent to the point of filter symmetry.
3. Repeat Step 2 for each coefficient.
4. Implement the checksum write as per the specified format.
5. Use the following methods to verify that the filter coefficients have been downloaded correctly:
 - Read the status register, checking the DL_OK bit.
 - Start reading data and observe the status of the DL_OK bit.

Note that because the user coefficients are stored in RAM, they are cleared after a RESET operation or a loss of power.

Table 13. Filter Length Values

FLEN[3:0]	Number of Coefficients	Filter Length
0000	Default	Default
0001	6	12
0011	12	24
0101	18	36
0111	24	48
1001	30	60
1011	36	72
1101	42	84
1111	48	96

EXAMPLE FILTER DOWNLOAD

The following is an example of downloading a short, user-defined filter with 24 taps. The frequency response is shown in Figure 38.

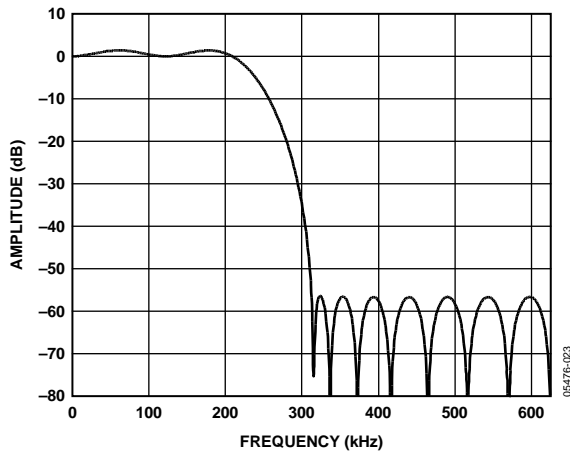

Figure 38. 24-Tap FIR Frequency Response

The coefficients for the filter in Table 14 are shown from the center of symmetry outward; that is, Coefficient 1 is the coefficient at the center of symmetry. The raw coefficients were generated using a commercial filter design tool and scaled appropriately so their sum equals 67108863 (0x3FF FFFF).

Table 14. 24-Tap FIR Coefficients

Coefficient	Raw	Scaled
1	+0.365481974	+53188232
2	+0.201339905	+29300796
3	+0.009636604	+1402406
4	-0.075708848	-11017834
5	-0.042856209	-6236822
6	+0.019944246	+2902466
7	+0.036437914	+5302774
8	+0.007592007	+1104856
9	-0.021556583	-3137108
10	-0.024888355	-3621978
11	-0.012379538	-1801582
12	-0.001905756	-277343

Table 15 shows the 32-bit word (as per the format shown in the Downloading a User-Defined Filter section) in hexadecimal for each of the coefficients that must be written to the AD7763 to realize this filter. The table is also split into the bytes that are all summed to produce the checksum. The checksum generated from these coefficients is 0x0E6B.

Table 15. Filter Hex Values¹

Coefficient	32-Bit Word Written to Download Coefficient			
	Byte 1	Byte 2	Byte 3	Byte 4
1	03	2B	96	88
2	01	BF	18	3C
3	00	15	66	26
4	04	A8	1E	6A
5	04	5F	2A	96
6	00	2C	49	C2
7	00	50	E9	F6
8	00	10	DB	D8
9	04	2F	DE	54
10	04	37	44	5A
11	04	1B	7D	6E
12	04	04	3B	5F

¹ All values of words listed are with reference to writing to one device only (ALL = 0) with Address 000 (as assigned to the device using the ADR[2:0] pins).

Table 16 lists in hexadecimal format the sequence of 32-bit words the user writes to the AD7763 to set up the ADC and download this filter, assuming selection of an output data rate of 625 kHz.

Table 16.

Word ¹	Description
0x0001807A	Address of Control Register 1. Control register data. DL filter, set filter length = 24, set output data rate = 625 kHz.
0x032B9688	First coefficient.
0x01BF183C	Second coefficient.
...	Other coefficients.
0x04043B5F	Twelfth (final) coefficient.
0x00000E6B	Checksum. Wait $(0.5 \times t_{CLK} \times \text{number of unused coefficients})$ for AD7763 to fill remaining unused coefficients with 0s.
0x0001087A	Address of Control Register. Control register data. Set read status and maintain filter length and decimation settings. Read contents of status register. Check Bit 7 (DL_OK) to determine that the filter downloaded correctly.

¹ All values of words listed are with reference to writing to one device only (ALL = 0) with Address 000 (as assigned to the device using the ADR[2:0] pins).

REGISTERS

The AD7763 has a number of user-programmable registers. The control registers are used to set the decimation rate, the filter configuration, the low power option, and the control of the differential amplifier. There are also digital gain, offset, and overrange threshold registers.

Writing to these registers involves writing the register address first, followed by a 16-bit data-word. Register addresses, details of individual bits, and default values are shown here.

CONTROL REGISTER 1—ADDRESS 0X001

Default Value 0x001A

MSB

LSB

DL Filt	RD Ovr	RD Gain	RD Off	RD Stat	0	SYNC	FLEN3	FLEN2	FLEN1	FLEN0	BYP F3	1	DEC2	DEC1	DEC0
---------	--------	---------	--------	---------	---	------	-------	-------	-------	-------	--------	---	------	------	------

Table 17.

Bit	Mnemonic	Comment
15	DL Filt ¹	Download Filter. Before downloading a user-defined filter, this bit must be set. The filter length bits must also be set at this time. The write operations that follow are interpreted as the user coefficients for the FIR filter until all the coefficients and the checksum have been written.
14	RD Ovr ^{1, 2}	Read Overrange. If this bit is set, the next read operation outputs the contents of the overrange threshold register instead of a conversion result.
13	RD Gain ^{1, 2}	Read Gain. If this bit is set, the next read operation outputs the contents of the digital gain register.
12	RD Off ^{1, 2}	Read Offset. If this bit is set, the next read operation outputs the contents of the digital offset register.
11	RD Stat ^{1, 2}	Read Status. If this bit is set, the next read operation outputs the contents of the status register.
10	0	0 must be written to this bit.
9	SYNC ¹	Synchronize. Setting this bit initiates an internal synchronization routine. Setting this bit simultaneously on multiple devices synchronizes all filters.
8 to 5	FLEN[3:0]	Filter Length Bits. These bits must be set when the DL Filt bit is set and before a user-defined filter is downloaded.
4	BYP F3	Bypass Filter 3. If this bit is a 0, Filter 3 (programmable FIR) is bypassed.
3	1	1 must be written to this bit.
2 to 0	DEC[2:0]	Decimation Rate. These bits set the decimation rate of Filter 2. Writing a value of 0, 1, or 2 corresponds to 4× decimation. A value of 3 corresponds to 8× decimation; a value of 4 corresponds to 16×; and the maximum value of 5 corresponds to 32× decimation.

¹ Bit 15 to Bit 9 are all self-clearing bits.

² Only one of these bits can be set in any write operation, because they all determine the contents of the next operation.

CONTROL REGISTER 2—ADDRESS 0X002

Default Value 0x009B

MSB

LSB

0	0	0	0	0	0	0	0	0	0	0	0	0	0	PD	LPWR	1	D1PD
---	---	---	---	---	---	---	---	---	---	---	---	---	---	----	------	---	------

Table 18.

Bit	Mnemonic	Comment
3	PD	Power Down. Setting this bit powers down the AD7763, reducing the power consumption to 6.35 mW.
2	LPWR	Low Power. If this bit is set, the AD7763 operates in a low power mode. The power consumption is reduced for a 3 dB reduction in noise performance.
1	1	1 must be written to this bit.
0	D1PD	Differential Amplifier Power Down. Setting this bit powers down the on-chip differential amplifier.

STATUS REGISTER (READ ONLY)

MSB											LSB				
PART 1	PART 0	DIE 2	DIE 1	DIE 0	0	LPWR	OVR	DL_OK	FILTER_OK	UFILTER	BYP F3	1	DEC2	DEC1	DEC0

Table 19.

Bit	Mnemonic	Comment
15,14	PART[1:0]	Part Number. These bits are constant for the AD7763.
13 to 11	DIE[2:0]	Die Number. These bits reflect the current AD7763 die number for identification purposes within a system.
10	0	0 must be written to this bit.
9	LPWR	Low Power. If the AD7763 is operating in low power mode, this bit is set to 1.
8	OVR	If the current analog input exceeds the current overrange threshold, this bit is set.
7	DL_OK	When downloading a user filter to the AD7763, a checksum is generated. This checksum is compared to the one downloaded following the coefficients. If these checksums agree, this bit is set.
6	FILTER_OK	When a user-defined filter is in use, a checksum is generated when the filter coefficients pass through the filter. This generated checksum is compared to the one downloaded. If they match, this bit is set.
5	UFILTER	If a user-defined filter is in use, this bit is set.
4	BYP F3	Bypass Filter 3. If Filter 3 is bypassed by setting the relevant bit in Control Register 1, this bit is also set.
3	1	1 must be written to this bit.
2 to 0	DEC[2:0]	Decimation Rate. These bits correspond to the bits set in Control Register 1.

OFFSET REGISTER—ADDRESS 0X003**Non Bit-Mapped, Default Value 0x0000**

The offset register uses twos complement notation and is scaled so that 0x7FFF (maximum positive value) and 0x8000 (maximum negative value) correspond to an offset of +0.390625% and -0.390625%, respectively. Offset correction is applied after any gain correction. Using the default gain value of 1.25 and assuming a reference voltage of 4.096 V, the offset correction range is approximately ± 25 mV.

GAIN REGISTER—ADDRESS 0X004**Non Bit-Mapped, Default Value 0xA000**

The gain register is scaled so that 0x8000 corresponds to a gain of 1.0. The default value of this register is 1.25 (0xA000). This gives a full-scale digital output when the input is at 80% of V_{REF} . This ties in with the maximum analog input range of $\pm 80\%$ of V_{REF} p-p.

OVERRANGE REGISTER—ADDRESS 0X005**Non Bit-Mapped, Default Value 0xCCCC**

The overrange register value is compared with the output of the first decimation filter to obtain an overload indication with minimum propagation delay. This is prior to any gain scaling or offset adjustment. The default value is 0xCCCC, which corresponds to 80% of V_{REF} (the maximum permitted analog input voltage). Assuming $V_{REF} = 4.096$ V, the bit is then set when the input voltage exceeds approximately 6.55 V p-p differential. Note that the overrange bit is also set immediately if the analog input voltage exceeds 100% of V_{REF} for more than 4 consecutive samples at the modulator rate.

NOTES

NOTES

NOTES