

FEATURES

Low on resistance: 0.8 Ω maximum at 125°C
0.25 Ω maximum on resistance flatness
1.8 V to 5.5 V single supply
200 mA current carrying capability
Automotive temperature range: -40°C to +125°C
Rail-to-rail operation
6-lead SOT-23, 8-lead MSOP, and 6-ball WLCSP packages
Fast switching times
Typical power consumption (<0.01 μ W)
TTL-/CMOS-compatible inputs
Pin compatible with the [ADG719](#)

APPLICATIONS

Power routing
Battery-powered systems
Communication systems
Data acquisition systems
Cellular phones
Modems
PCMCIA cards
Hard drives
Relay replacement

GENERAL DESCRIPTION

The [ADG819](#) is a monolithic, CMOS, single-pole, double-throw (SPDT) switch. This switch is designed on a submicron process that provides low power dissipation yet gives high switching speed, low on resistance, and low leakage currents.

Low power consumption and an operating supply range of 1.8 V to 5.5 V make the [ADG819](#) ideal for battery-powered, portable instruments.

Each switch of the [ADG819](#) conducts equally well in both directions when on. The [ADG819](#) exhibits break-before-make switching action, thus preventing momentary shorting when switching channels.

The [ADG819](#) is available in a 6-lead SOT-23 package, an 8-lead MSOP package, and in a 6-ball WLCSP package. This chip occupies only a 1.14 mm \times 2.18 mm area, making it the ideal candidate for space-constrained applications.

FUNCTIONAL BLOCK DIAGRAM

Figure 1.

PRODUCT HIGHLIGHTS

1. Very low on resistance, 0.5 Ω typical.
2. 1.8 V to 5.5 V single-supply operation.
3. High current carrying capability.
4. Tiny 6-lead SOT-23, 8-lead MSOP, and 6-ball, 1.14 mm \times 2.18 mm WLCSP packages.

Rev. A

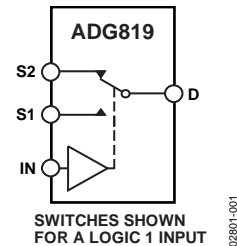
Information furnished by Analog Devices is believed to be accurate and reliable. However, no responsibility is assumed by Analog Devices for its use, nor for any infringements of patents or other rights of third parties that may result from its use. Specifications subject to change without notice. No license is granted by implication or otherwise under any patent or patent rights of Analog Devices. Trademarks and registered trademarks are the property of their respective owners.

ADG819* Product Page Quick Links

Last Content Update: 08/30/2016

[Comparable Parts](#)

View a parametric search of comparable parts

[Evaluation Kits](#)

- Evaluation Board for 6 lead SOT23 Devices in the Switches/Multiplexers Portfolio

[Documentation](#)

Application Notes

- AN-617: MicroCSP Wafer Level Chip Scale Package

Data Sheet

- ADG819: 0.5 Ω , CMOS, 1.8 V to 5.5 V, 2:1 Mux/SPDT Switch Datasheet

User Guides

- UG-948: Evaluation Board for 6-Lead SOT-23 Devices in the Switches and Multiplexers Portfolio

[Tools and Simulations](#)

- ADG819 SPICE Macro Model

[Reference Designs](#)

- CN0363

[Reference Materials](#)

Product Selection Guide

- Switches and Multiplexers Product Selection Guide

Technical Articles

- CMOS Switches Offer High Performance in Low Power, Wideband Applications
- Data-acquisition system uses fault protection
- Enhanced Multiplexing for MEMS Optical Cross Connects
- Temperature monitor measures three thermal zones

[Design Resources](#)

- ADG819 Material Declaration
- PCN-PDN Information
- Quality And Reliability
- Symbols and Footprints

[Discussions](#)

View all ADG819 EngineerZone Discussions

[Sample and Buy](#)

Visit the product page to see pricing options

[Technical Support](#)

Submit a technical question or find your regional support number

TABLE OF CONTENTS

Features	1	ESD Caution.....	5
Applications.....	1	Pin Configurations and Function Descriptions	6
Functional Block Diagram	1	Typical Performance Characteristics	7
General Description	1	Test Circuits.....	9
Product Highlights	1	Terminology	11
Revision History	2	Outline Dimensions	12
Specifications.....	3	Ordering Guide	13
Absolute Maximum Ratings.....	5		

REVISION HISTORY

5/12—Rev. 0 to Rev. A

Updated Format.....	Universal
Deleted ADG820	Universal
Changes to General Description	1
Changes to Table 1	3
Changes to Table 2.....	4
Change to WLCSP θ_{JA} Thermal Impedance Parameter, Table 3	5
Added Table 5 and Table 6; Renumbered Sequentially	6
Deleted Test Circuit 6; Renumbered Sequentially	8
Changes to Figure 11 to Figure 14.....	8
Changes to Terminology Section.....	11
Updated Outline Dimensions	12
Changes to Ordering Guide	13

5/02—Revision 0: Initial Version

SPECIFICATIONS

$V_{DD} = 5\text{ V} \pm 10\%$, $GND = 0\text{ V}$, unless otherwise noted.

Table 1.

Parameter	25°C	-40°C to +85°C	-40°C to +125°C	Unit	Test Conditions/Comments
ANALOG SWITCH					
Analog Signal Range			0 V to V_{DD}	V	
On Resistance, R_{ON} ¹	0.5			Ω typ	$V_S = 0\text{ V to }V_{DD}$, $I_S = 100\text{ mA}$; see Figure 16
	0.6	0.7	0.8	Ω max	
On Resistance Match Between Channels, ΔR_{ON} ¹	0.06			Ω typ	$V_S = 0\text{ V to }V_{DD}$, $I_S = 100\text{ mA}$
	0.08	0.1	0.12	Ω max	
On Resistance Flatness, $R_{FLAT(ON)}$ ¹	0.1			Ω typ	$V_S = 0\text{ V to }V_{DD}$, $I_S = 100\text{ mA}$
	0.17	0.2	0.25	Ω max	
LEAKAGE CURRENTS					
Source Off Leakage, I_S (Off)	± 0.01			nA typ	$V_{DD} = 5.5\text{ V}$ $V_S = 4.5\text{ V}/1\text{ V}$, $V_D = 1\text{ V}/4.5\text{ V}$; see Figure 17
	± 0.25	± 3	± 10	nA max	
Channel On Leakage, I_D , I_S (On)	± 0.01			nA typ	$V_S = V_D = 1\text{ V}$, or $V_S = V_D = 4.5\text{ V}$; see Figure 18
	± 0.25	± 3	± 25	nA max	
DIGITAL INPUTS					
Input High Voltage, V_{INH}			2.0	V min	
Input Low Voltage, V_{INL}			0.8	V max	
Input Current					
I_{INL} or I_{INH}	0.005			μA typ	$V_{IN} = V_{INL}$ or V_{INH}
			± 0.1	μA max	
Digital Input Capacitance, C_{IN}	5			pF typ	
DYNAMIC CHARACTERISTICS²					
t_{ON}	35			ns typ	$R_L = 50\ \Omega$, $C_L = 35\text{ pF}$, $V_S = 3\text{ V}$; see Figure 19
	45	50	55	ns max	
t_{OFF}	10			ns typ	$R_L = 50\ \Omega$, $C_L = 35\text{ pF}$, $V_S = 3\text{ V}$; see Figure 19
	16	18	21	ns max	
Break-Before-Make Time Delay, t_{BBM}	5			ns typ	$R_L = 50\ \Omega$, $C_L = 35\text{ pF}$, $V_{S1} = V_{S2} = 3\text{ V}$; see Figure 20
			1	ns min	
Charge Injection	20			pC typ	$V_S = 2.5\text{ V}$, $R_S = 0\ \Omega$, $C_L = 1\text{ nF}$; see Figure 21
Off Isolation	-71			dB typ	$R_L = 50\ \Omega$, $C_L = 5\text{ pF}$, $f = 100\text{ kHz}$; see Figure 22
Channel-to-Channel Crosstalk	-72			dB typ	$R_L = 50\ \Omega$, $C_L = 5\text{ pF}$, $f = 100\text{ kHz}$; see Figure 24
Bandwidth, -3 dB	17			MHz typ	$R_L = 50\ \Omega$, $C_L = 5\text{ pF}$; see Figure 23
C_S (Off)	80			pF typ	$f = 1\text{ MHz}$
C_D , C_S (On)	300			pF typ	$f = 1\text{ MHz}$
POWER REQUIREMENTS					
I_{DD}	0.001			μA typ	$V_{DD} = 5.5\text{ V}$, digital inputs = 0 V or 5.5 V
		1.0	2.0	μA max	

¹ On resistance parameters tested with $I_S = 10\text{ mA}$.

² Guaranteed by design; not subject to production test.

$V_{DD} = 2.7\text{ V to }3.6\text{ V}$, $GND = 0\text{ V}$, unless otherwise noted.

Table 2.

Parameter	25°C	-40°C to +85°C	-40°C to +125°C	Unit	Test Conditions/Comments
ANALOG SWITCH					
Analog Signal Range			0 V to V_{DD}	V	
On Resistance, R_{ON} ¹	0.7			Ω typ	$V_S = 0\text{ V to }V_{DD}$, $I_S = 100\text{ mA}$; see Figure 16
	1.4	1.5	1.6	Ω max	
On Resistance Match Between Channels, ΔR_{ON} ¹	0.06			Ω typ	$V_S = 0\text{ V to }V_{DD}$, $I_S = 100\text{ mA}$
		0.13	0.13	Ω max	
On Resistance Flatness, $R_{FLAT(ON)}$ ¹	0.25			Ω typ	$V_S = 0\text{ V to }V_{DD}$, $I_S = 100\text{ mA}$
LEAKAGE CURRENTS					
Source Off Leakage, I_S (Off)	± 0.01			nA typ	$V_{DD} = 3.6\text{ V}$
	± 0.25	± 3	± 10	nA max	$V_S = 3.3\text{ V}/1\text{ V}$, $V_D = 1\text{ V}/3.3\text{ V}$; see Figure 17
Channel On Leakage, I_D , I_S (On)	± 0.01			nA typ	$V_S = V_D = 1\text{ V}$, or $V_S = V_D = 3.3\text{ V}$; see Figure 18
	± 0.25	± 3	± 25	nA max	
DIGITAL INPUTS					
Input High Voltage, V_{INH}			2.0	V min	
Input Low Voltage, V_{INL}			0.8	V max	
Input Current I_{INL} or I_{INH}	0.005		± 0.1	μA typ μA max	$V_{IN} = V_{INL}$ or V_{INH}
Digital Input Capacitance, C_{IN}	5			pF typ	
DYNAMIC CHARACTERISTICS²					
t_{ON}	40			ns typ	$R_L = 50\ \Omega$, $C_L = 35\text{ pF}$, $V_S = 1.5\text{ V}$; see Figure 19
	60	65	70	ns max	
t_{OFF}	10			ns typ	$R_L = 50\ \Omega$, $C_L = 35\text{ pF}$, $V_S = 1.5\text{ V}$; see Figure 19
	16	18	21	ns max	
Break-Before-Make Time Delay, t_{BBM}	40			ns typ	$R_L = 50\ \Omega$, $C_L = 35\text{ pF}$, $V_{S1} = V_{S2} = 1.5\text{ V}$; see Figure 20
			1	ns min	
Charge Injection	10			pC typ	$V_S = 1.5\text{ V}$, $R_S = 0\ \Omega$, $C_L = 1\text{ nF}$; see Figure 21
Off Isolation	-71			dB typ	$R_L = 50\ \Omega$, $C_L = 5\text{ pF}$, $f = 100\text{ kHz}$; see Figure 22
Channel-to-Channel Crosstalk	-72			dB typ	$R_L = 50\ \Omega$, $C_L = 5\text{ pF}$, $f = 100\text{ kHz}$; see Figure 24
Bandwidth, -3 dB	17			MHz typ	$R_L = 50\ \Omega$, $C_L = 5\text{ pF}$; see Figure 23
C_S (Off)	80			pF typ	$f = 1\text{ MHz}$
C_D , C_S (On)	300			pF typ	$f = 1\text{ MHz}$
POWER REQUIREMENTS					
I_{DD}	0.001			μA typ	$V_{DD} = 3.6\text{ V}$, digital Inputs = 0 V or 3.6 V
		1.0	2.0	μA max	

¹ On resistance parameters tested with $I_S = 10\text{ mA}$.

² Guaranteed by design; not subject to production test.

ABSOLUTE MAXIMUM RATINGS

$T_A = 25^\circ\text{C}$, unless otherwise noted

Table 3.

Parameter	Rating
V_{DD} to GND	-0.3 V to +7 V
Analog Inputs ¹	-0.3 V to $V_{DD} + 0.3$ V or 30 mA, whichever occurs first
Digital Inputs ¹	-0.3 V to $V_{DD} + 0.3$ V or 30 mA, whichever occurs first
Peak Current, Sx or D	400 mA (pulsed at 1 ms, 10% duty cycle maximum)
Continuous Current, Sx or D	200 mA
Operating Temperature Range	
Industrial	-40°C to +85°C
Automotive	-40°C to +125°C
Storage Temperature Range	-65°C to +150°C
Junction Temperature	150°C
MSOP	
θ_{JA} Thermal Impedance	206°C/W
θ_{JC} Thermal Impedance	44°C/W
SOT-23 (4-Layer Board)	
θ_{JA} Thermal Impedance	119°C/W
WLCSP (4-Layer Board)	
θ_{JA} Thermal Impedance	80°C/W
Lead Temperature, Soldering (10 sec)	300°C
IR Reflow, Peak Temperature (<20 sec)	235°C

¹ Overvoltages at IN, Sx, or D are clamped by internal diodes. Current should be limited to the maximum ratings given.

Stresses above those listed under Absolute Maximum Ratings may cause permanent damage to the device. This is a stress rating only; functional operation of the device at these or any other conditions above those indicated in the operational section of this specification is not implied. Exposure to absolute maximum rating conditions for extended periods may affect device reliability.

Only one absolute maximum rating can be applied at any one time.

Table 4. Truth Table for the ADG819

IN	Switch S1	Switch S2
0	On	Off
1	Off	On

ESD CAUTION



ESD (electrostatic discharge) sensitive device. Charged devices and circuit boards can discharge without detection. Although this product features patented or proprietary protection circuitry, damage may occur on devices subjected to high energy ESD. Therefore, proper ESD precautions should be taken to avoid performance degradation or loss of functionality.

PIN CONFIGURATIONS AND FUNCTION DESCRIPTIONS

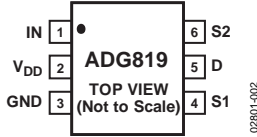

Figure 2. 6-Lead SOT-23 Pin Configuration

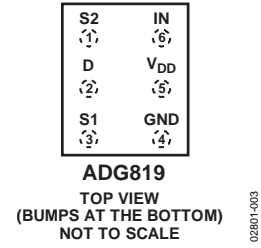

Figure 3. 6-Ball WLCSP Pin Configuration

Table 5. 6-Lead SOT-23 and 6-Ball WLCSP Pin Function Descriptions

Pin No.		Mnemonic	Description
SOT-23	WLCSP		
1	6	IN	Logic Control Input.
2	5	V _{DD}	Most Positive Power Supply Potential.
3	4	GND	Ground (0 V) Reference.
4	3	S1	Source Terminal. Can be an input or output.
5	2	D	Drain Terminal. Can be an input or output.
6	1	S2	Source Terminal. Can be an input or output.

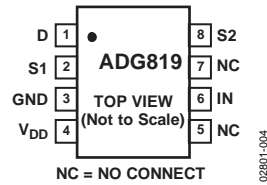

Figure 4. 8-Lead MSOP Pin Configuration

Table 6. 8-Lead MSOP Pin Function Descriptions

Pin No.	Mnemonic	Description
1	D	Drain Terminal. Can be an input or output.
2	S1	Source Terminal. Can be an input or output.
3	GND	Ground (0 V) Reference.
4	V _{DD}	Most Positive Power Supply Potential.
5	NC	No Connect. Do not connect to this pin.
6	IN	Logic Control Input.
7	NC	No Connect. Do not connect to this pin.
8	S2	Source Terminal. Can be an input or output.

TYPICAL PERFORMANCE CHARACTERISTICS

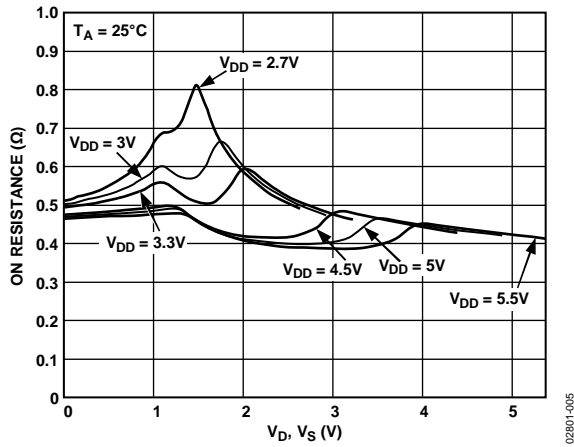

Figure 5. On Resistance vs. V_D , V_S

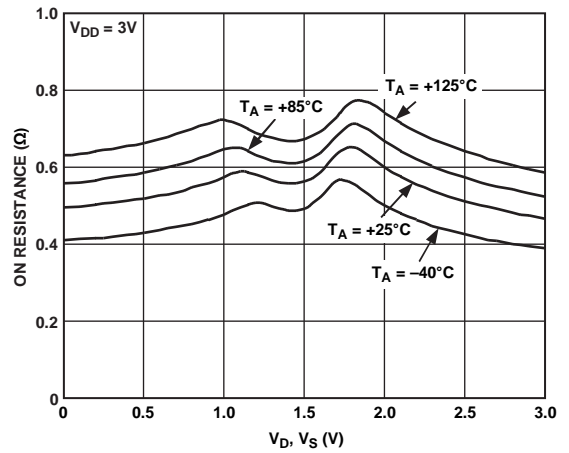

Figure 8. On Resistance vs. V_D , V_S for Different Temperatures

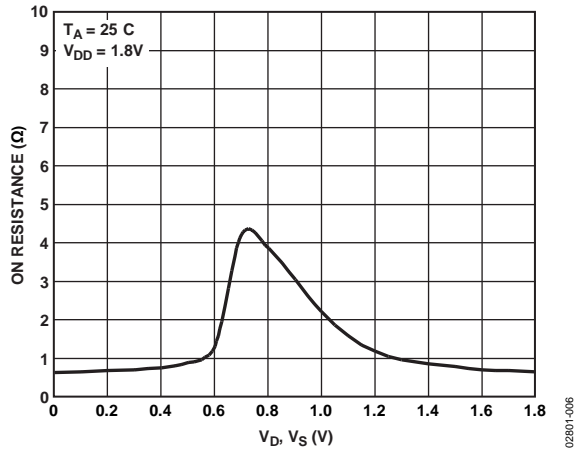

Figure 6. On Resistance vs. V_D , V_S

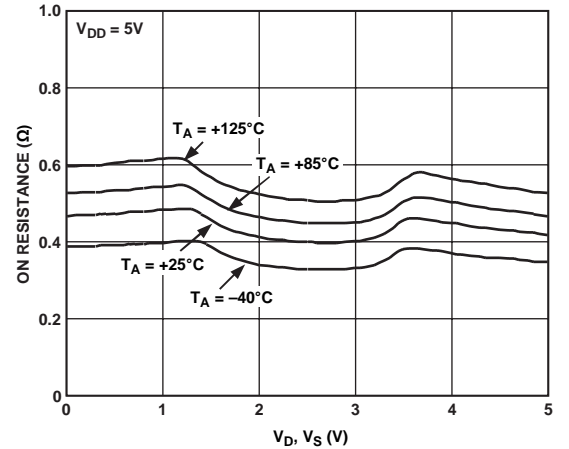

Figure 9. On Resistance vs. V_D , V_S for Different Temperatures

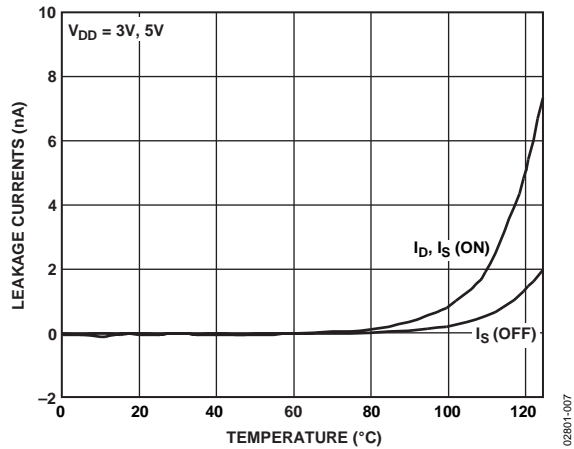

Figure 7. Leakage Currents vs. Temperature

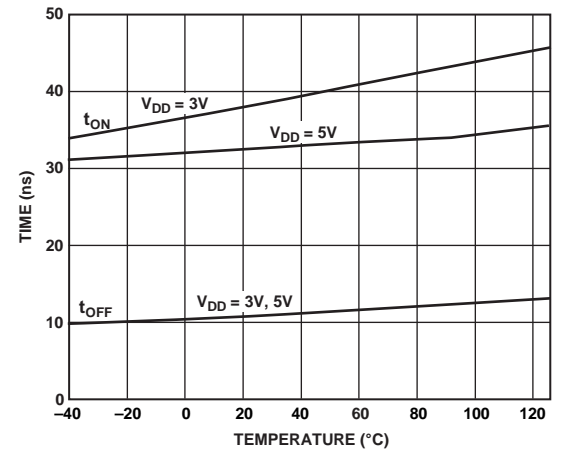

Figure 10. t_{ON}/t_{OFF} Times vs. Temperature

02801-005

02801-008

02801-006

02801-009

02801-007

02801-010

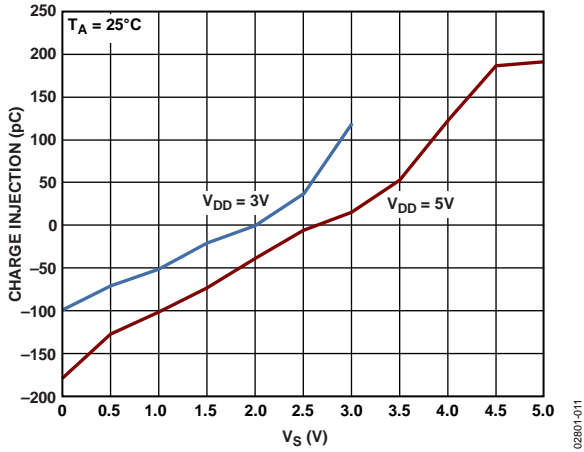

Figure 11. Charge Injection vs. V_S (Source Voltage)

02801-011

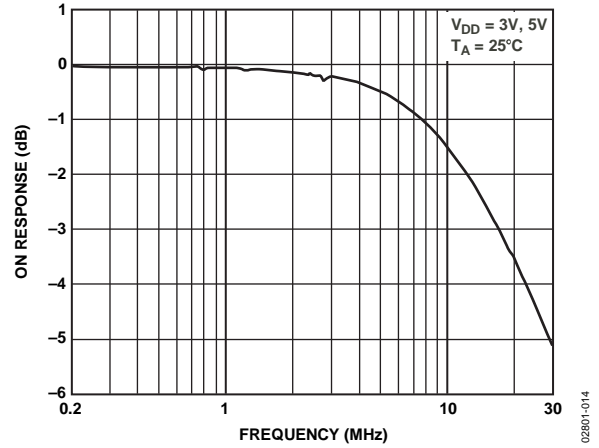

Figure 14. On Response vs. Frequency

02801-014

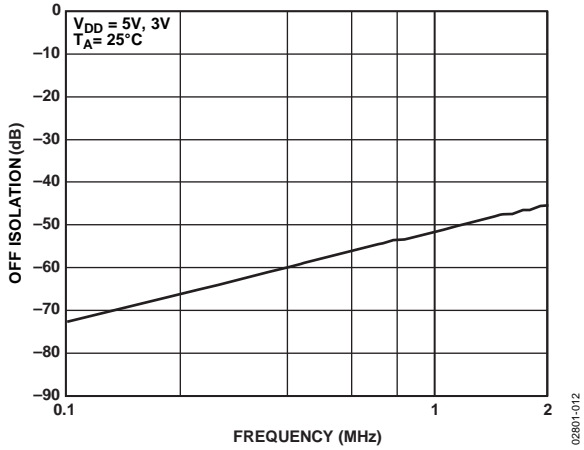

Figure 12. Off Isolation vs. Frequency

02801-012

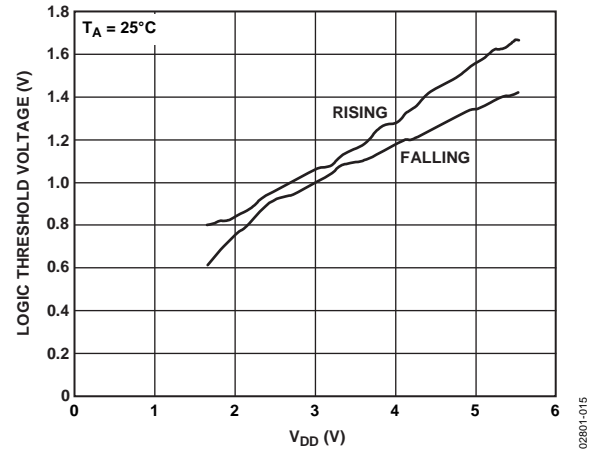

Figure 15. Logic Threshold Voltage vs. Supply Voltage

02801-015

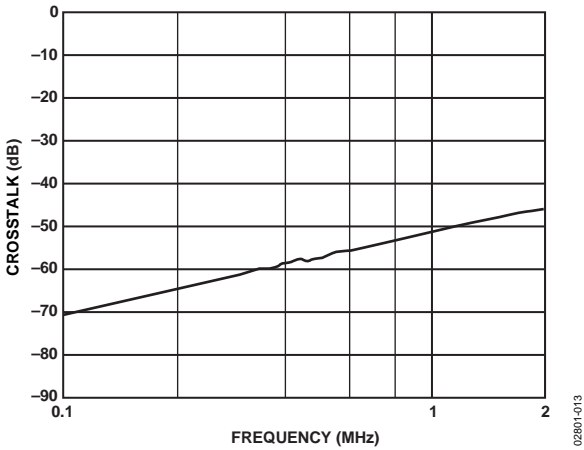

Figure 13. Crosstalk vs. Frequency

02801-013

TEST CIRCUITS

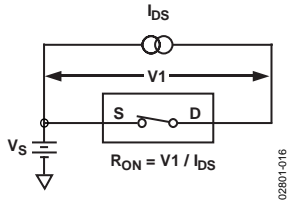

Figure 16. On Resistance

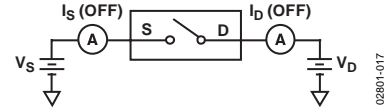

Figure 17. Off Leakage

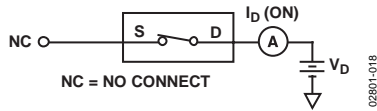

Figure 18. On Leakage

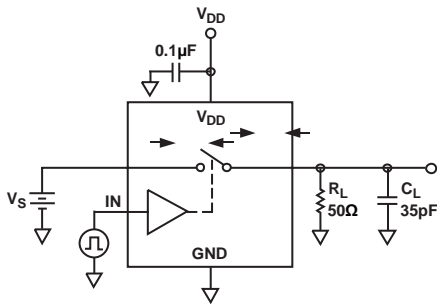

Figure 19. Switching Times

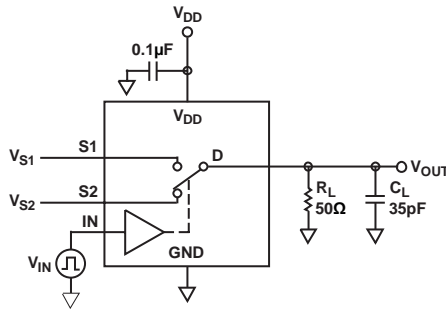
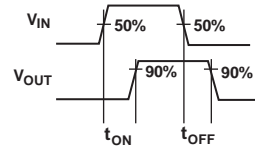

Figure 20. Break-Before-Make Time Delay, t_{BBM}

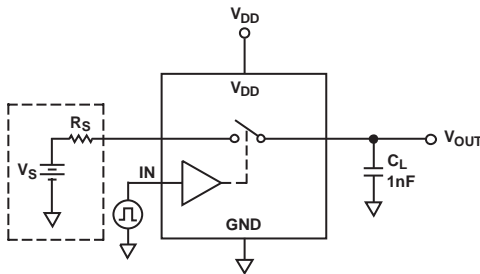
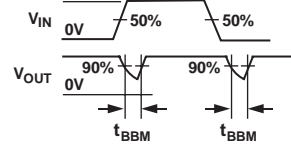
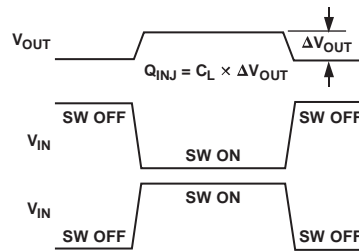

Figure 21. Charge Injection



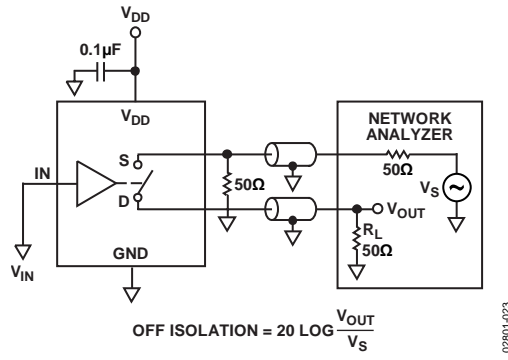

Figure 22. Off Isolation

02801-023

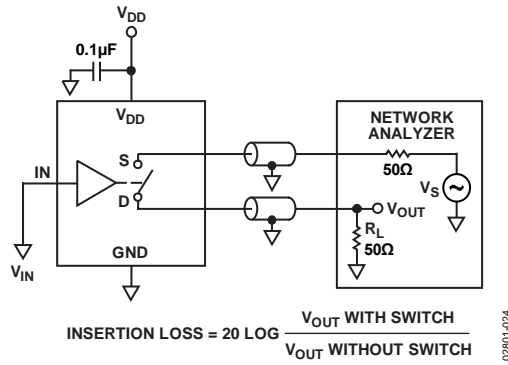

Figure 23. Bandwidth

02801-024

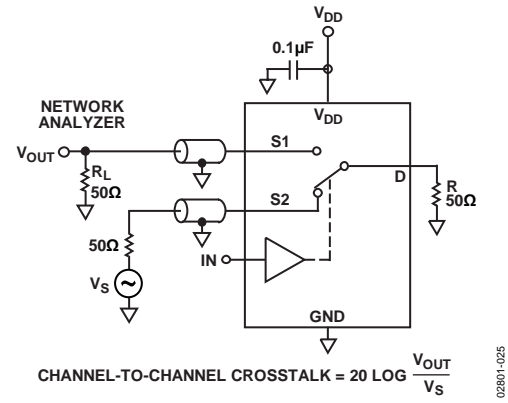

Figure 24. Channel-to-Channel Crosstalk

02801-025

TERMINOLOGY

R_{ON}

Ohmic resistance between D and Sx.

ΔR_{ON}

On resistance match between any two channels, that is, R_{ON} maximum – R_{ON} minimum.

$R_{FLAT(ON)}$

Flatness is defined as the difference between the maximum and minimum value of on resistance as measured over the specified analog signal range.

I_S (Off)

Source leakage current with the switch off.

I_D, I_S (On)

Channel leakage current with the switch on.

V_D (V_S)

Analog voltage on Terminal D and Terminal S.

V_{INL}

Maximum input voltage for Logic 0.

V_{INH}

Minimum input voltage for Logic 1.

I_{INL} (I_{INH})

Input current of the digital input.

C_S (Off)

Off switch source capacitance.

C_D, C_S (On)

On switch capacitance.

t_{ON}

Delay between applying the digital control input and the output switching on.

t_{OFF}

Delay between applying the digital control input and the output switching off.

t_{BBM}

Off time or on time measured between the 90% points of both switches when switching from one address state to another.

Charge Injection

A measure of the glitch impulse transferred from the digital input to the analog output during switching.

Channel-to-Channel Crosstalk

A measure of unwanted signal coupled through from one channel to another as a result of parasitic capacitance.

Off Isolation

A measure of unwanted signal coupling through an off switch.

Bandwidth

Frequency at which the output is attenuated by –3 dB.

On Response

Frequency response of the on switch.

OUTLINE DIMENSIONS

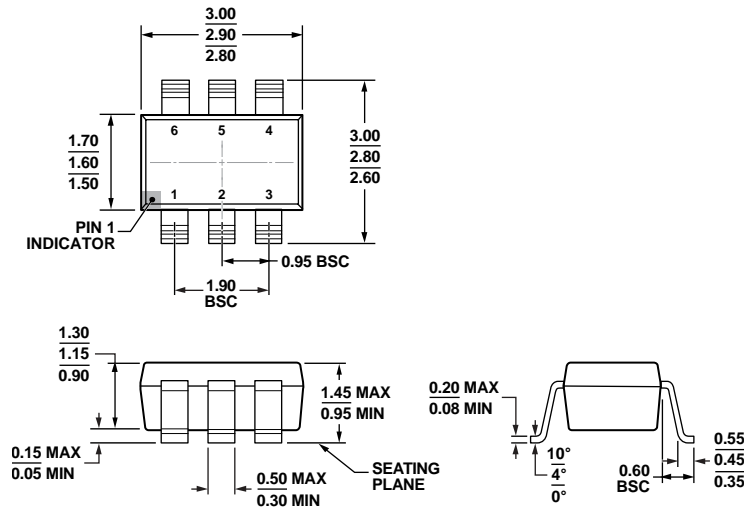

COMPLIANT TO JEDEC STANDARDS MO-178-AB

Figure 25. 6-Lead Small Outline Transistor Package [SOT-23] (RJ-6)

Dimensions shown in millimeters

12-16-2008-A

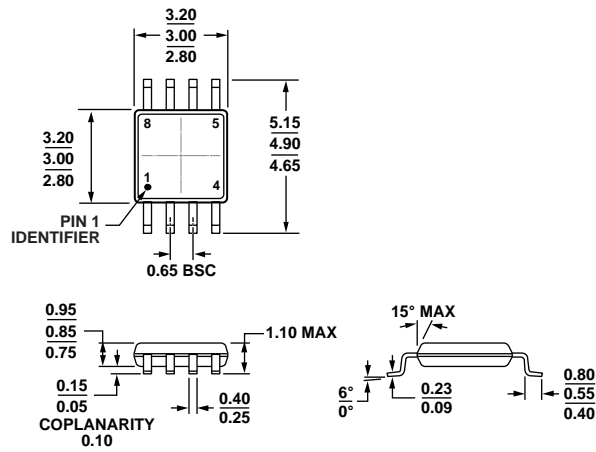

COMPLIANT TO JEDEC STANDARDS MO-187-AA

Figure 26. 8-Lead mini Small Outline Package [MSOP] (RM-8)

Dimensions shown in millimeters

10-07-2008-B

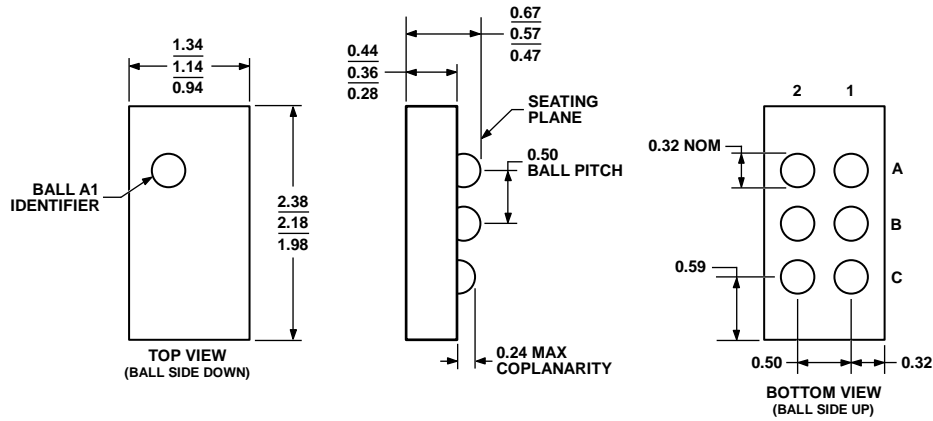

Figure 27. 6-Ball Wafer Level Chip Scale Package [WLCSP] (CB-6-1)
Dimensions shown in millimeters

02-03-2012-A

ORDERING GUIDE

Model ¹	Notes	Temperature Range	Package Description	Package Option	Branding ²
ADG819BCBZ-REEL	³	-40°C to +85°C	6-Ball Wafer Level Chip Package [WLCSP]	CB-6-1	SBC
ADG819BCBZ-REEL7	³	-40°C to +85°C	6-Ball Wafer Level Chip Package [WLCSP]	CB-6-1	SBC
ADG819BRM		-40°C to +125°C	8-Lead Mini Small Outline Package [MSOP]	RM-8	SNB
ADG819BRM-REEL		-40°C to +125°C	8-Lead Mini Small Outline Package [MSOP]	RM-8	SNB
ADG819BRMZ		-40°C to +125°C	8-Lead Mini Small Outline Package [MSOP]	RM-8	SBC
ADG819BRMZ-REEL7	³	-40°C to +125°C	8-Lead Mini Small Outline Package [MSOP]	RM-8	SBC
ADG819BRT-500RL7	³	-40°C to +125°C	6-Lead Small Outline Transistor Package [SOT-23]	RJ-6	SNB
ADG819BRT-REEL7	³	-40°C to +125°C	6-Lead Small Outline Transistor Package [SOT-23]	RJ-6	SNB
ADG819BRTZ-500RL7	³	-40°C to +125°C	6-Lead Small Outline Transistor Package [SOT-23]	RJ-6	SBC
ADG819BRTZ-REEL	³	-40°C to +125°C	6-Lead Small Outline Transistor Package [SOT-23]	RJ-6	SBC
ADG819BRTZ-REEL7	³	-40°C to +125°C	6-Lead Small Outline Transistor Package [SOT-23]	RJ-6	SBC

¹ Z = RoHS Compliant Part.

² Branding on these packages is limited to three characters due to space constraints.

³ Contact factory for availability.

NOTES

NOTES

NOTES