

Ultimate Miniature Size Connector With Integral Cable Clamp Cap

Glass Filled Nylon Range -29 to 220°C (-20 to 425°F)

SMPW-CC Series



- ✓ Integral Cap+Cable Clamp
- ✓ Strain Relief With Grommet
- ✓ Captive Cover Screws
- ✓ Captive Clamp Screws
- ✓ Accepts Stranded or Solid Wire as Small as 40 AWG Up to 20 AWG, or Overbraid, TWSH, Armored Up to 5.5 mm (0.22") OD
- ✓ Contact Washers for Quick Connect Wire Termination
 - Use Straight Wire
 - No Wire Loop Required
- ✓ Internal Wire Divider
- ✓ Write-On Window
- ✓ Combination Phillips/Slot Screws
- ✓ 100% Top Side Assembly

**Incredible Labor Saver!
No Loose Screws, All
Cover Screws Are
Captive!**

Terminate straight wire,
wire loop not necessary.

Back plate 1/8" supplied
adjustable to hold
40 AWG to 5.5 mm
(0.22") OD.

Grommets included,
visit newportUS.com
for grommet options.

Contact
washers.

All screws are
combination head.

SMPW-CC-K-M shown
larger than actual size.

Actual size.

SMPW-CC-K-F
shown
larger than
actual size.

**Side Load
Equal to
Stainless Steel**

**Reduce Assembly
Time From 3 Minutes
to Less Than
1 Minute!**

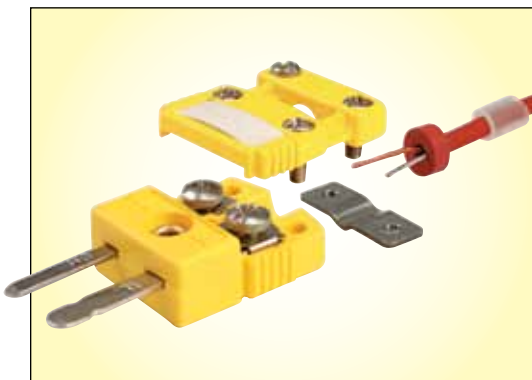

SMPW-CC-K-M shown actual size.

SMPW-CC-K-F shown actual size.

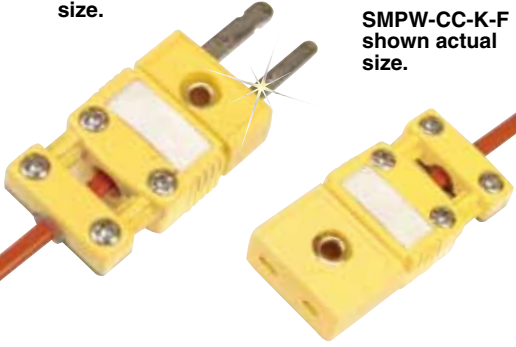

Discount Schedule	
1-10	Net
11-49	5%
50-99	10%
100-999	15%
1000-4999	20%
5000 and over	25%

Pull Test Highest Rating

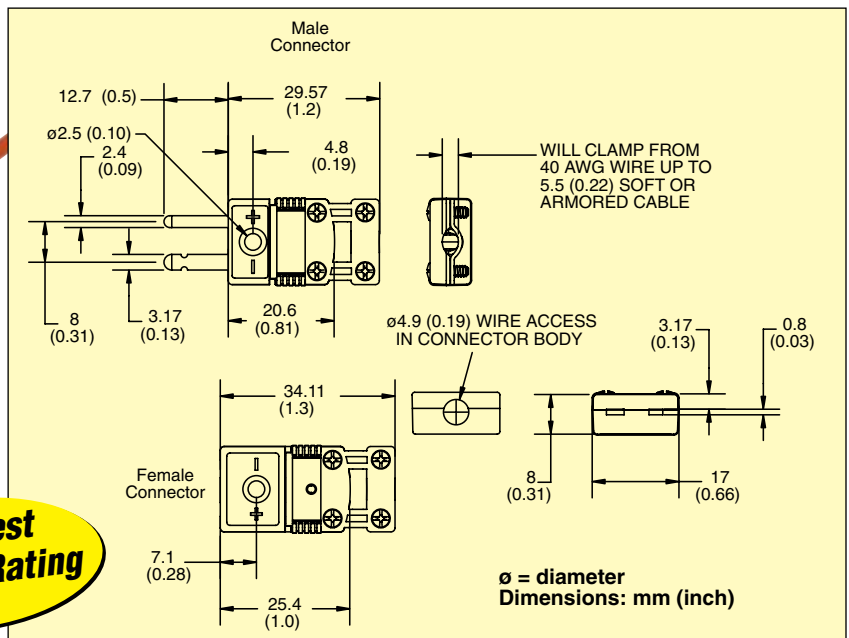

To Order Visit newportUS.com/smpw-cc for Pricing and Details

Alloy Code	Compensating Alloy Used in Connector		ANSI Color Code	Glass-Filled Nylon Model Number	
	(+)	(-)		Male	Female
K	CHROMEOMEGA	ALOMEGA	Yellow	SMPW-CC-K-M	SMPW-CC-K-F
T	Copper	Constantan	Blue	SMPW-CC-T-M	SMPW-CC-T-F
J	Iron	Constantan	Black	SMPW-CC-J-M	SMPW-CC-J-F
E	CHROMEOMEGA	Constantan	Purple	SMPW-CC-E-M	SMPW-CC-E-F
R/S	Copper	RNX/SNX	Green	SMPW-CC-R/S-M	SMPW-CC-R/S-F
C	CPX	CNX	Red	SMPW-CC-C-M	SMPW-CC-C-F
U	Copper	Copper	White	SMPW-CC-U-M	SMPW-CC-U-F
N	OMEGA-P	OMEGA-N	Orange	SMPW-CC-N-M	SMPW-CC-N-F

*To order a pair: Replace suffix "M" with "MF" for a connector pair.
Ordering Example: SMPW-CC-K-M clamp cap, Type K, flat pin male.

Quick Assembly Tool!

SMP-CC-TOOL shown smaller than actual size.

