

CLASSIFICATION	PRODUCT SPECIFICATION	No. DS-1761-2400-102	REV. 0.5
SUBJECT	CLASS 2 BLUETOOTH LOW ENERGY + NFC SINGLE MODE MODULE	PAGE	1 of 29
CUSTOMER'S CODE PAN1761	PANASONIC'S CODE ENW89848A1KF	DATE	09.06.2016

Product Specification

Applicant / Manufacturer Panasonic Industrial Devices Europe GmbH
Hardware Zeppelinstrasse 19
 21337 Lüneburg
 Germany

Applicant / Manufacturer Toshiba
Software

Software Version Please refer to chapter 19

By purchase of any of products described in this document the customer accepts the document's validity and declares their agreement and understanding of its contents and recommendations. Panasonic reserves the right to make changes as required without notification.

Power Electronics R&D Center Wireless Connectivity Panasonic Industrial Devices Europe GmbH	APPROVED genehmigt	CHECKED geprüft	DESIGNED erstellt
---	-----------------------	--------------------	----------------------

CLASSIFICATION	PRODUCT SPECIFICATION	No. DS-1761-2400-102	REV. 0.5
SUBJECT	CLASS 2 BLUETOOTH LOW ENERGY + NFC SINGLE MODE MODULE	PAGE	2 of 29
CUSTOMER'S CODE PAN1761	PANASONIC'S CODE ENW89848A1KF	DATE	09.06.2016

TABLE OF CONTENTS

1.	Scope of this Document	4
2.	Key Features	4
3.	Bluetooth Low Energy	5
4.	Applications for the Module	5
5.	Description for the Module.....	5
6.	Detailed Description	6
6.1.	PAN1761 Terminal Layout	6
7.	PAN1761 Block Diagram.....	8
8.	Test Conditions	9
9.	General Device Requirements and Operation	9
9.1.	Absolute Maximum Ratings.....	9
9.2.	Recommended Operating Conditions.....	9
9.3.	Power up sequence	10
9.4.	PAN1761 Current Consumption	10
10.	Bluetooth RF Performance	11
10.1.	PAN1761 Bluetooth Characteristics	11
10.2.	PAN1761 NFC tag Interface.....	11
10.2.1.	NFC Operational Sequence	12
	Soldering Temperature-Time Profile (for reflow soldering).....	13
10.3.	For lead solder	13
10.4.	For leadfree solder	13
11.	PAN1761 Module Dimension	14
12.	Footprint of the Module	15
13.	Case Marking	16
13.1.	Example for Marking	16
13.2.	Marking Definition	16
14.	Mechanical Requirements	16
15.	Development of Applications	17
16.	Reliability Tests	17
17.	Cautions.....	17
17.1.	Design Notes	17
17.2.	Installation Notes.....	18
17.3.	Usage Conditions Notes.....	18
17.4.	Storage Notes	19
17.5.	Safety Cautions.....	19
17.6.	Other cautions.....	19
18.	Packaging	21
18.1.	PAN1761 Tape Dimension.....	21
18.2.	Packing in Tape	22

CLASSIFICATION	PRODUCT SPECIFICATION	No. DS-1761-2400-102	REV. 0.5
SUBJECT	CLASS 2 BLUETOOTH LOW ENERGY + NFC SINGLE MODE MODULE	PAGE	3 of 29
CUSTOMER'S CODE PAN1761	PANASONIC'S CODE ENW89848A1KF	DATE	09.06.2016

18.3. Component Direction	22
18.4. Reel Dimension.....	23
18.5. Label for Package	24
18.6. Total Package	24
19. Ordering Information	25
20. RoHS and REACH Declaration	25
21. Data Sheet Status	25
22. History for this Document	25
23. Related Documents.....	26
24. Radiation Pattern of Antenna	27
25. General Information.....	29
26. Life Support Policy	29

CLASSIFICATION	PRODUCT SPECIFICATION	No. DS-1761-2400-102	REV. 0.5
SUBJECT	CLASS 2 BLUETOOTH LOW ENERGY + NFC SINGLE MODE MODULE	PAGE	4 of 29
CUSTOMER'S CODE PAN1761	PANASONIC'S CODE ENW89848A1KF	DATE	09.06.2016

1. SCOPE OF THIS DOCUMENT

This product specification applies to Panasonic's, Class 2, Bluetooth¹ low energy single mode module with NFC , series number: PAN1761

2. KEY FEATURES

- Same form factor and footprint as PAN1760
- Bluetooth 4.0 (LE) embedded GATT profile with high level API commands, compatible to Toshiba reference BLE profiles
- Surface mount type 15.6 x 8.7 x 1.8 mm³
- Tx power 0 dBm, Rx sensitivity -90 dBm
- Compliant to BT 4.0 (extension to 4.1 under development)
- 32kB on-chip RAM for application software and driver
- 512kBit eeprom to download user program during start up
- Operation with external host or as host-less (stand alone)
- Standard SIG BLE and "SPP over BLE" profiles available
- Temperature Range from -40°C to +85°C
- NFC Forum Tag Type 3 wired interface
- 1520kB built-in EEPROM NFC memory

¹ Bluetooth is a registered trademark of the Bluetooth Special Interest Group.

CLASSIFICATION	PRODUCT SPECIFICATION	No. DS-1761-2400-102	REV. 0.5
SUBJECT	CLASS 2 BLUETOOTH LOW ENERGY + NFC SINGLE MODE MODULE	PAGE	5 of 29
CUSTOMER'S CODE PAN1761	PANASONIC'S CODE ENW89848A1KF	DATE	09.06.2016

3. BLUETOOTH LOW ENERGY

Bluetooth Low Energy (BLE), part of Bluetooth Ver. 4.0, specifies two types of implementation: Single mode and dual mode. Single mode devices implement the low energy specification and consume just a fraction of the power of classic Bluetooth, allowing the short-range wireless standard to extend to coin cell battery applications for the first time. Dual mode devices combine Bluetooth Low Energy and classic Bluetooth and are likely to become a de facto feature in almost all new Bluetooth enabled cellular phones and computers.

Single mode Bluetooth 4.0 Low Energy is not backwards compatible with previous Bluetooth classic standards. Dual mode Bluetooth 4.0 is backwards compatible to Bluetooth classic and well suited for gateway applications, but is not practical for low power devices.

BLE single mode devices are called "Bluetooth Smart".



4. APPLICATIONS FOR THE MODULE

- All Embedded Wireless Applications
- Wearable Devices
- Health Care, Medical Diagnostic Systems
- Mobile phone accessories
- Industrial Measurement and Diagnostics
- Devices where Power Consumption is critical

5. DESCRIPTION FOR THE MODULE

The PAN1761 is a short-range, Class 2, BLE single mode module for implementing Bluetooth functionality into various electronic devices. A block diagram can be found in chapter 7.

The PAN1761 is a cost-effective, low-power, true system-on-chip (SoC) for Bluetooth low energy applications. It enables robust BLE central and peripheral nodes to be built with very low total bill-of-material costs. The PAN1761 combines an excellent RF transceiver programmable EEPROM memory, 32-KB RAM, and many other powerful supporting features and peripherals. The PAN1761 is suitable for systems where very low power consumption is required. Very low-power sleep modes are available. Short transition times between operating modes further enable low power consumption.

Panasonic PAN1761 offers an embedded and certified Bluetooth low energy protocol stack and BLE GATT profile inside the silicon device from Toshiba. The Bluetooth low energy protocol stack from Toshiba, is a flexible and cost-effective single-mode Bluetooth low energy solution. Standard BLE or proprietary profiles are available for seamless integration into the application code.

Please contact your local sales office for further details on additional options and services:

www.panasonic.com/rfmodules for the US,

http://industrial.panasonic.com/eu/i/29606/wireless_modules/wireless_modules.html for EU

or write an e-mail to wireless@eu.panasonic.com.

CLASSIFICATION	PRODUCT SPECIFICATION	No. DS-1761-2400-102	REV. 0.5
SUBJECT	CLASS 2 BLUETOOTH LOW ENERGY + NFC SINGLE MODE MODULE	PAGE	6 of 29
CUSTOMER'S CODE PAN1761	PANASONIC'S CODE ENW89848A1KF	DATE	09.06.2016

6. DETAILED DESCRIPTION

6.1. PAN1761 TERMINAL LAYOUT

Top View, Application PCB

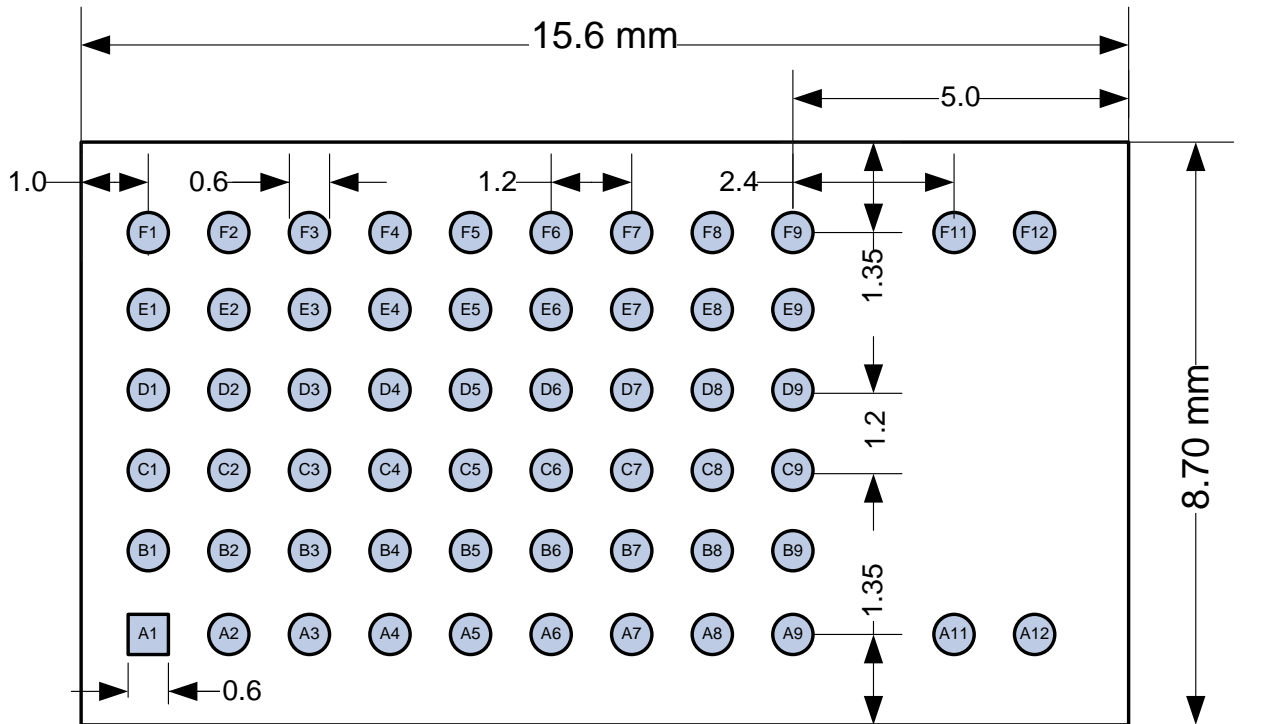

CLASSIFICATION	PRODUCT SPECIFICATION	No. DS-1761-2400-102	REV. 0.5
SUBJECT	CLASS 2 BLUETOOTH LOW ENERGY + NFC SINGLE MODE MODULE	PAGE	7 of 29
CUSTOMER'S CODE PAN1761	PANASONIC'S CODE ENW89848A1KF	DATE	09.06.2016

No	PIN Name	Alternative PIN	Pin Type	Description
A1	GND		Ground Pin	Connect to Ground
A2	NC			Not Connected
A3	Reset		Digital Input	Reset, active-low
A4	VCC		Power	2V – 3.6V analog/digital power supply connection
A5	VCC		Power	2V – 3.6V analog/digital power supply connection
A6	VCC		Power	2V – 3.6V analog/digital power supply connection
A7	GND		Ground Pin	Connect to Ground
A8	NC			Not Connected
A9	GND		Ground Pin	Connect to Ground
A11	GND		Ground Pin	Connect to Ground
A12	GND		Ground Pin	Connect to Ground
B1	NC			Not Connected
B2	TAG_L0		NFC_Antenna	
B3	TAG_SCL		NFC_I2C	
B4	NC			Not Connected
B5	NC			Not Connected
B6	NC			Not Connected
B7	NC			Not Connected
B8	NC			Not Connected
B9	NC			Not Connected
C1	NC			Not Connected
C2	TAG_L1		NFC_Antenna	
C3	TAG_RFDET		Digital Out	
C4	NC			Not Connected
C5	NC			Not Connected
C6	TAG_READYX		Digital Out	
C7	TAG_SDA	PWM2	NFC_I2C	
C8	GND		Ground Pin	Connect to Ground
C9	GND		Ground Pin	Connect to Ground
D1	NC			Not Connected
D2	NC			Not Connected
D3	GPIO1	AIN0	Digital I/O	
D4	Wakup	GPIO0	Digital I/O	
D5	NC			Not Connected
D6	TAG_PONX		Digital In	
D7	GND		Ground Pin	Connect to Ground
D8	GND		Ground Pin	Connect to Ground
D9	NC			Not Connected/Placeholder for Antenna
E1	GPIO8	SDA	Digital I/O	Connected to internal EEPROM
E2	GPIO7	SCL	Digital I/O	Connected to internal EEPROM
E3	NC			Not Connected
E4	NC			Not Connected
E5	TAG_RECTOUT			
E6	UART_RXD	GPIO4	Digital In	
E7	GPIO2	PWM0/AIN1	Digital I/O	
E8	GND		Ground Pin	Connect to Ground
E9	GND		Ground Pin	Connect to Ground
F1	GND		Ground Pin	Connect to Ground
F2	EEPROM_WP		Digital In	EEPROM write protect /active low
F3	NC			Not Connected
F4	NC			Not Connected
F5	GPIO6	UART_1-CTS/ UART2-RX	Digital In	Can be configured to UART2_RXD
F6	SLEEPXCLKIN		Clock	32.768 KHz sleep clock input
F7	UART_TXD	GPIO3	Digital Out	
F8	GPIO5	UART1_RTS/ UART2-TX	Digital I/O	Can be configured to UART2_TXD

CLASSIFICATION	PRODUCT SPECIFICATION	No. DS-1761-2400-102	REV. 0.5
SUBJECT	CLASS 2 BLUETOOTH LOW ENERGY + NFC SINGLE MODE MODULE	PAGE	8 of 29
CUSTOMER'S CODE PAN1761	PANASONIC'S CODE ENW89848A1KF	DATE	09.06.2016

F9	GND		Ground Pin	Connect to Ground
F11	GND		Ground Pin	Connect to Ground
F12	GND		Ground Pin	Connect to Ground

7. PAN1761 BLOCK DIAGRAM

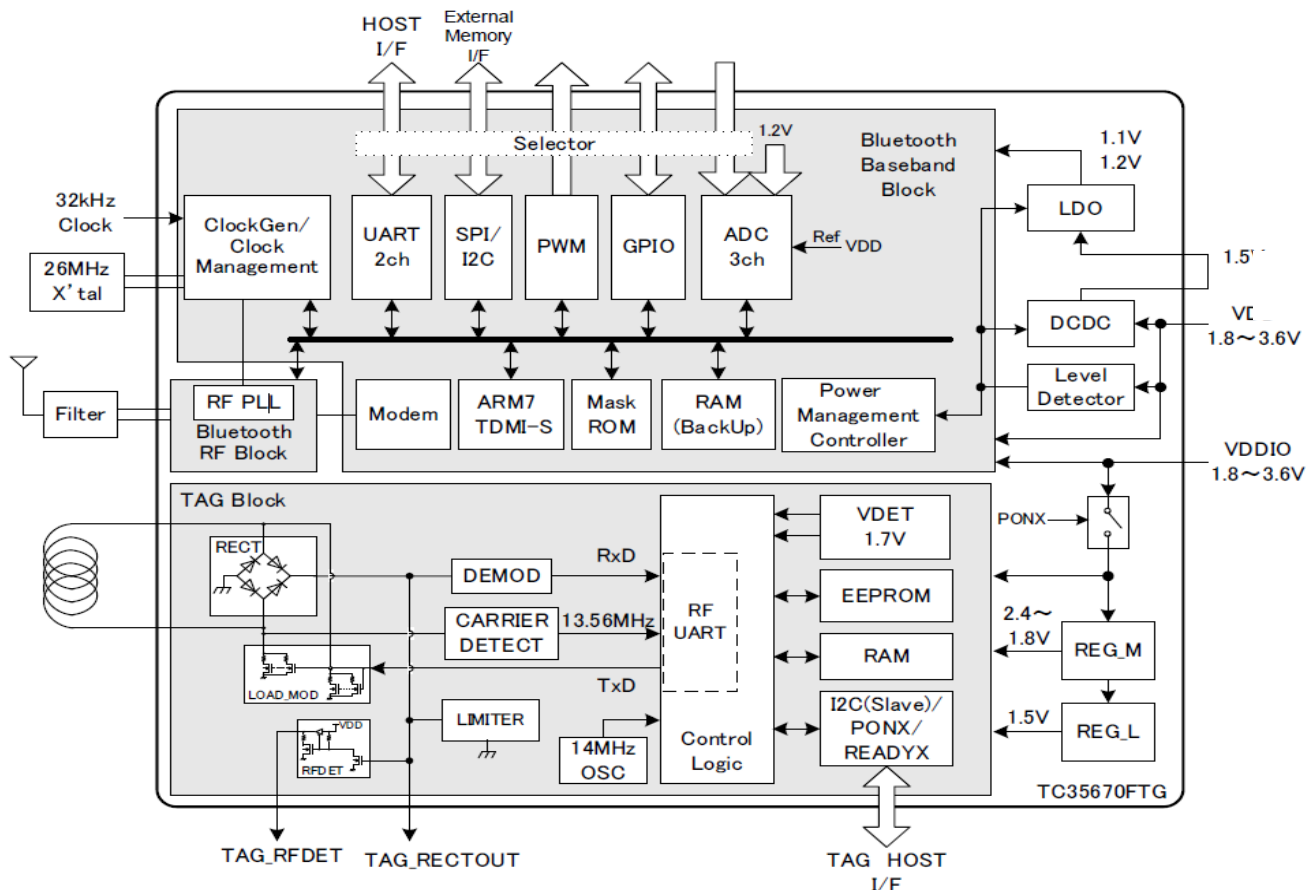
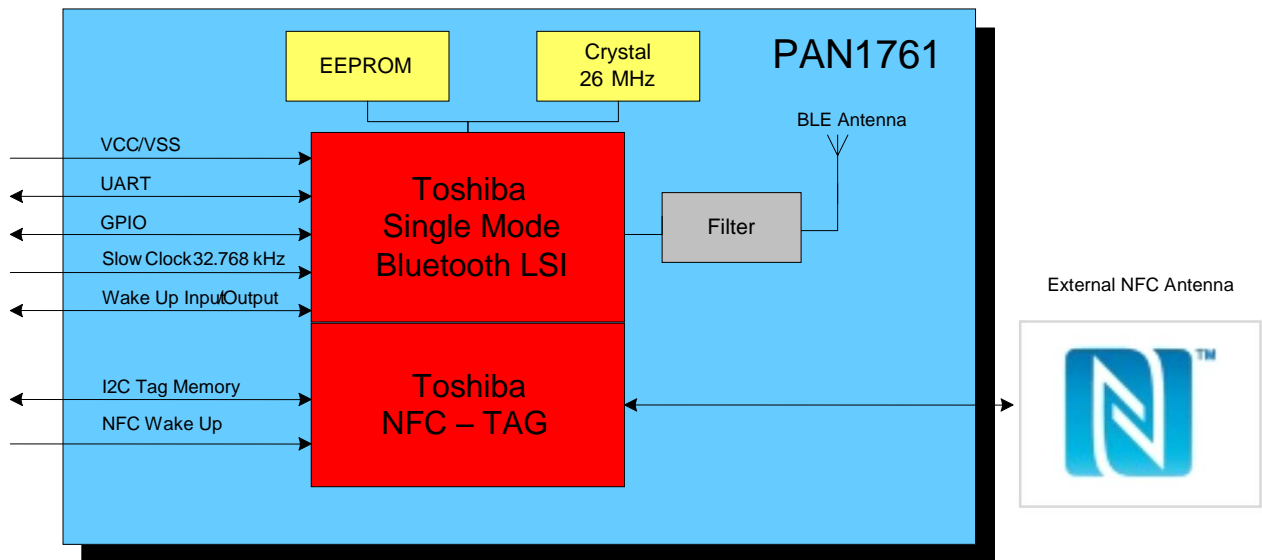

CLASSIFICATION	PRODUCT SPECIFICATION	No. DS-1761-2400-102	REV. 0.5
SUBJECT	CLASS 2 BLUETOOTH LOW ENERGY + NFC SINGLE MODE MODULE	PAGE	9 of 29
CUSTOMER'S CODE PAN1761	PANASONIC'S CODE ENW89848A1KF	DATE	09.06.2016

8. Test Conditions

Measurements shall be made under operating free-air temperature range unless otherwise specified.

Temperature	25 ± 10°C
Humidity	40 to 85%RH
Supply Voltage	3.3V

9. GENERAL DEVICE REQUIREMENTS AND OPERATION

All specifications are over temperature and process, unless indicated otherwise.

9.1. ABSOLUTE MAXIMUM RATINGS

No	See ²	Value	Unit
Ratings Over Operating Free-Air Temperature Range			
1	Voltage on any digital pin	-0.3 to VDD+0.3	V
2	Operating ambient temperature range	-40 to 85	°C
3	Storage temperature range	-40 to 125	°C
4	Bluetooth RF inputs	10	dBm
5	ESD: All pads, according to human-body model, JEDEC STD 22, method A114 According to charged-device model, JEDEC STD 22, method C101	1000	V
		500	

9.2. RECOMMENDED OPERATING CONDITIONS

No	Rating	Min	Typ	Max	Unit
1	Power supply voltage	1.7	1.8	1.9	V
1	Power supply voltage	2.7	3.3	3.6	V
2	Maximum ambient operating temperature		-40	85	°C

² Stresses beyond those listed under "absolute maximum ratings" may cause permanent damage to the device. These are stress ratings only and functional operation of the device at these or any other conditions beyond those indicated under "recommended operating conditions" is not implied. Exposure to absolute-maximum-rated conditions for extended periods may affect device reliability.

CLASSIFICATION	PRODUCT SPECIFICATION	No. DS-1761-2400-102	REV. 0.5
SUBJECT	CLASS 2 BLUETOOTH LOW ENERGY + NFC SINGLE MODE MODULE	PAGE	10 of 29
CUSTOMER'S CODE PAN1761	PANASONIC'S CODE ENW89848A1KF	DATE	09.06.2016

9.3. POWER UP SEQUENCE

When the power is turned on, set reset signal to low (RESET=Low). After OSC is stable, release reset (RESET=High).

Crystal oscillator stabilizing time is about 2 msec, so define release time after sufficient evaluation.

When the power is turned off, set reset signal to low (RESET=Low).

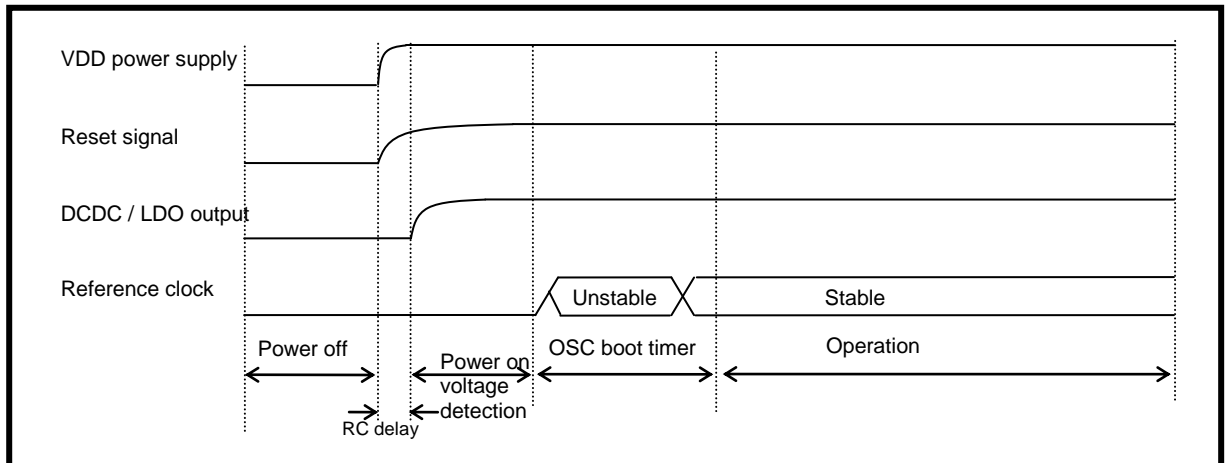

9.4. PAN1761 CURRENT CONSUMPTION

The current consumption is dependent on the user scenario and the setup and timing in the low power modes. The total power consumption can be optimized by adjusting advertising and connection intervals. It also depends on the system configuration of the central device (typically mobile phone or BLE hub).

CLASSIFICATION	PRODUCT SPECIFICATION	No. DS-1761-2400-102	REV. 0.5
SUBJECT	CLASS 2 BLUETOOTH LOW ENERGY + NFC SINGLE MODE MODULE	PAGE	11 of 29
CUSTOMER'S CODE PAN1761	PANASONIC'S CODE ENW89848A1KF	DATE	09.06.2016

10. BLUETOOTH RF PERFORMANCE

10.1. PAN1761 BLUETOOTH CHARACTERISTICS

No	Characteristics	Condition	Min	Typ	Max	Unit
1	Operation frequency range		2402		2480	MHz
2	Channel spacing			2		MHz
3	Output Power	Maximum setting, measured at single ended 50ohm.		0		dBm
4	Sensitivity, High Gain Mode	High-gain mode		-90.0		dBm

10.2. PAN1761 NFC TAG INTERFACE

PAN1761 has a NFC Forum Type 3 Tag (NFC Tag) function built-in.

Features of PAN1761 NFC interface:

- Built-in Contactless IC Card Technology
- Wireless interface: Automatic detection of transmission speed 212kbps and 424kbps
- I2C interface: Maximum operational clock 400kHz
- Built-in EEPROM: General user area 1520 bytes, Protecting against defective data
- Writing time: 5ms(typ.), 1bit error automatic correction, CRC automatic addition, and error detection of read data.
- Security: Mutual authentication with Message authentication code (MAC), Variety access attributes can be set. Writing prohibition, reading after authentication, writing after authentication, writing with MAC

Technology refers to the following standards : JIS X 6319-4, ISO/IEC 18092

Basic technical characteristics are in table below:

No	Item	Remarks
1	Data transmission format	Half Duplex, synchronization
2	Carrier Frequency	13.56MHz
2	Data transmission speed	212,424 Kbit/s (Automatic detection)
3	Modulation	ASK
4	Coding	Manchester
5	Bit order	MSBF

CLASSIFICATION	PRODUCT SPECIFICATION	No. DS-1761-2400-102	REV. 0.5
SUBJECT	CLASS 2 BLUETOOTH LOW ENERGY + NFC SINGLE MODE MODULE	PAGE	12 of 29
CUSTOMER'S CODE PAN1761	PANASONIC'S CODE ENW89848A1KF	DATE	09.06.2016

10.2.1. NFC Operational Sequence

If a wireless carrier is detected, TAG_RFDET pin outputs high level. If the wireless carrier disappears, TAG_RFDET pin turns back to low level due to pull-down resistance. Set VDDIO and VDD pin to output high (power supply).. At Write without Encryption or Read without Encryption, if IDm stored in PAN1761 chip and iDm with command are consistent, TAG_READYX pin outputs high level. After that, during supply of internal power source, the high is kept. VDDIO and VDD pin needs power supply for TAG_READYX pin to output high.

By becoming high in TAG_READYX pin, HOST can get to know that wireless reader writer accesses PAN1761 module.

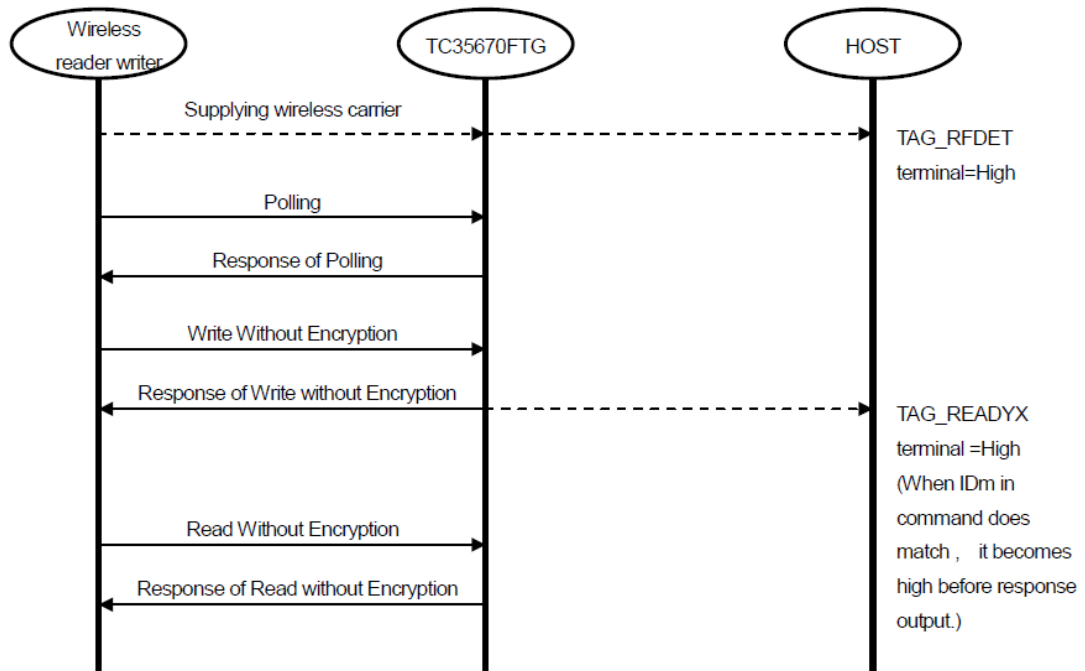

Sequence example of operation over the wireless TAG interface

CLASSIFICATION	PRODUCT SPECIFICATION	No. DS-1761-2400-102	REV. 0.5
SUBJECT	CLASS 2 BLUETOOTH LOW ENERGY + NFC SINGLE MODE MODULE	PAGE	13 of 29
CUSTOMER'S CODE PAN1761	PANASONIC'S CODE ENW89848A1KF	DATE	09.06.2016

SOLDERING TEMPERATURE-TIME PROFILE (FOR REFLOW SOLDERING)

10.3. FOR LEAD SOLDER

**Recommended temp. profile
for reflow soldering**

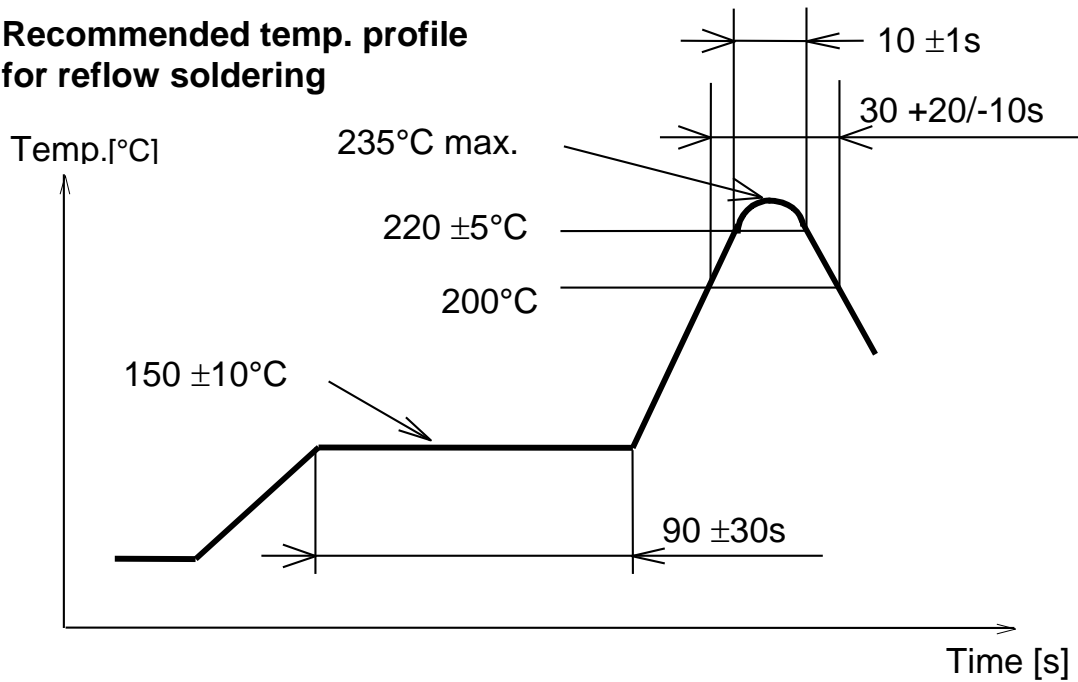

10.4. FOR LEADFREE SOLDER

**Our used temp. profile
for reflow soldering**

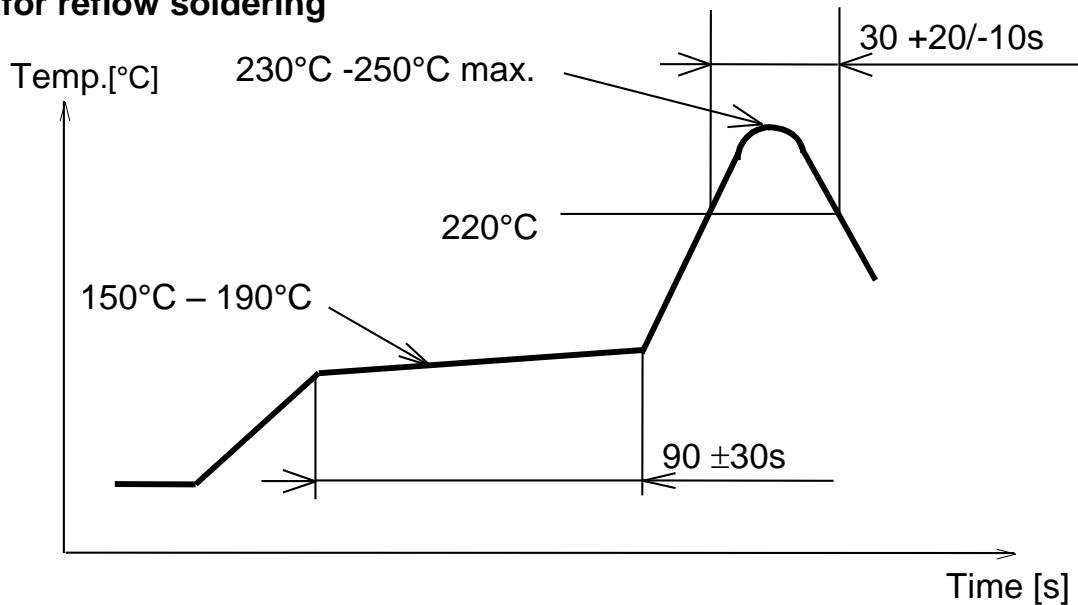

Reflow permissible cycle: 2
Opposite side reflow is prohibited due to module weight.

CLASSIFICATION	PRODUCT SPECIFICATION	No. DS-1761-2400-102	REV. 0.5
SUBJECT	CLASS 2 BLUETOOTH LOW ENERGY + NFC SINGLE MODE MODULE	PAGE	14 of 29
CUSTOMER'S CODE PAN1761	PANASONIC'S CODE ENW89848A1KF	DATE	09.06.2016

11. PAN1761 MODULE DIMENSION

No.	Item	Dimension	Tolerance	Remark
1	Width	8.70	± 0.30	
2	Length	15.60	± 0.30	
3	Height	1.80	± 0.20	With case

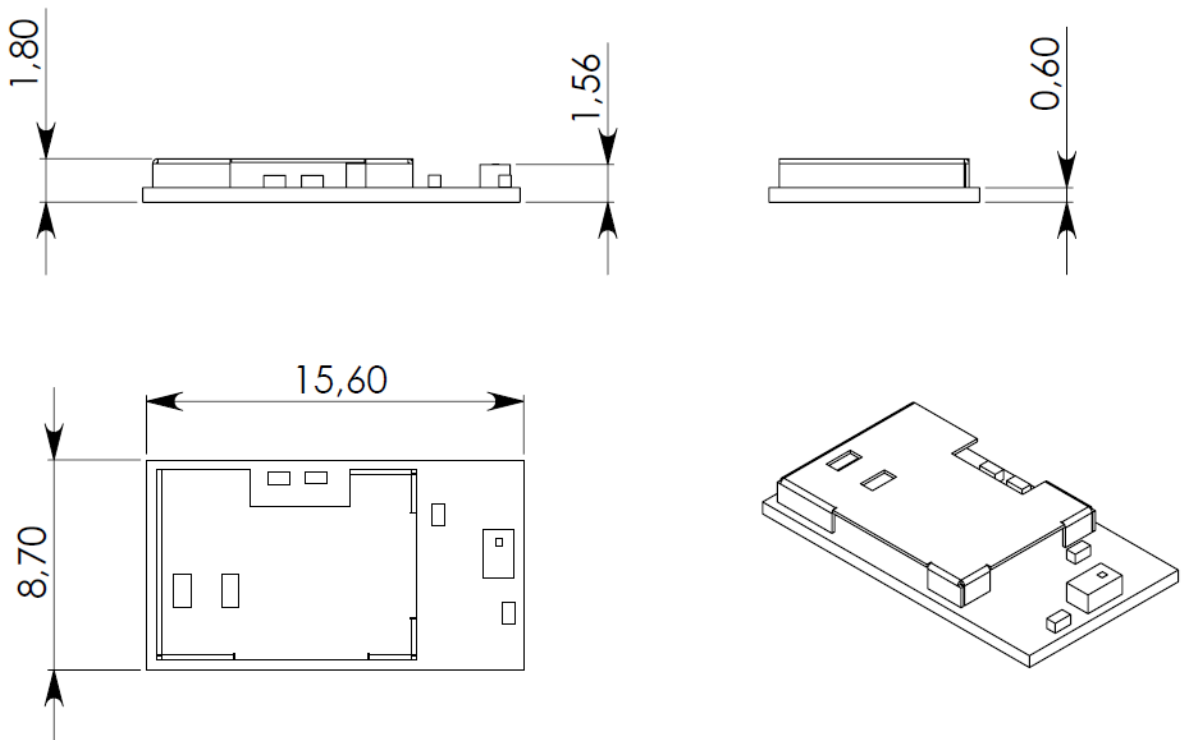

CLASSIFICATION	PRODUCT SPECIFICATION	No. DS-1761-2400-102	REV. 0.5
SUBJECT	CLASS 2 BLUETOOTH LOW ENERGY + NFC SINGLE MODE MODULE	PAGE	15 of 29
CUSTOMER'S CODE PAN1761	PANASONIC'S CODE ENW89848A1KF	DATE	09.06.2016

12. FOOTPRINT OF THE MODULE

All dimensions are in millimeters.

The outer dimensions have a tolerance of $\pm 0.3\text{mm}$.

Top view, Application PCB

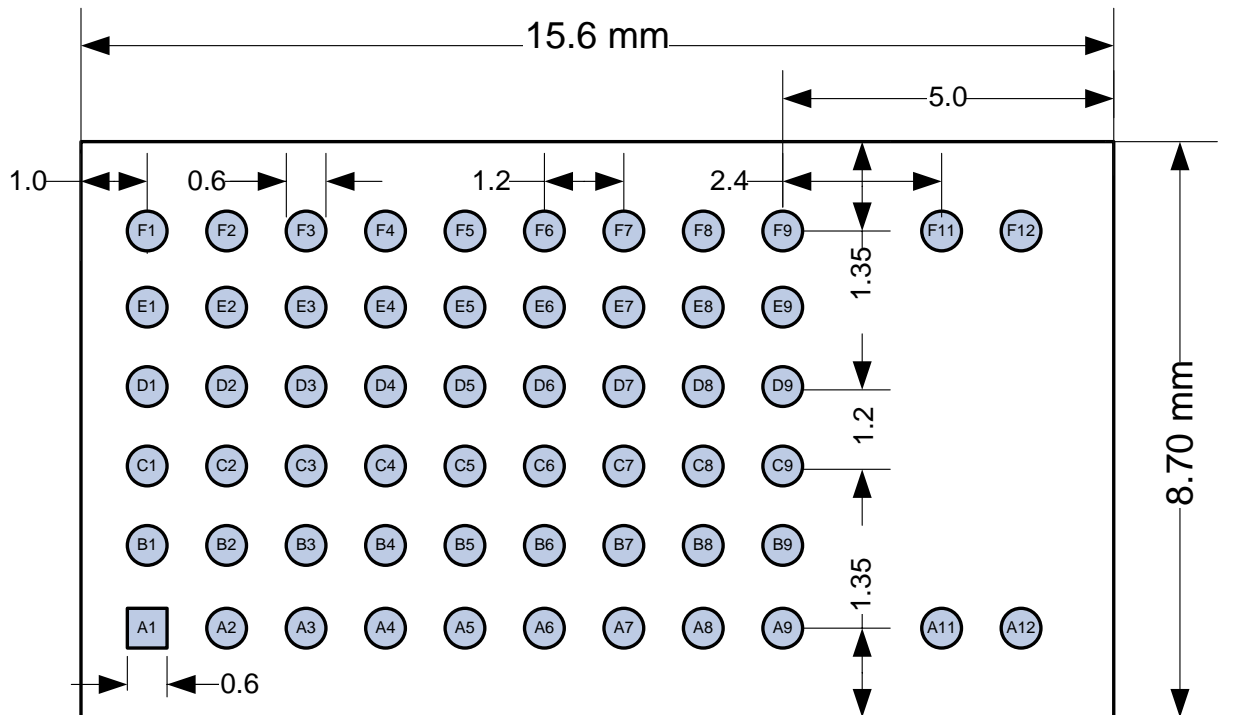

CLASSIFICATION	PRODUCT SPECIFICATION	No. DS-1761-2400-102	REV. 0.5
SUBJECT	CLASS 2 BLUETOOTH LOW ENERGY + NFC SINGLE MODE MODULE	PAGE	16 of 29
CUSTOMER'S CODE PAN1761	PANASONIC'S CODE ENW89848A1KF	DATE	09.06.2016

13. CASE MARKING

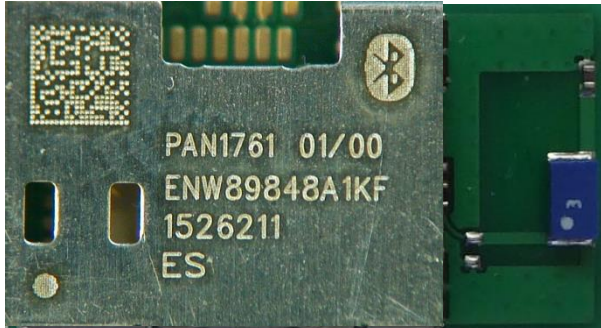

No.	Remark
1	Marking for Pin 1 (Circle 0,15 mm)
2	2D-Code, for internal usage only and can be change without any notice
3	Marking definition see below

13.1. EXAMPLE FOR MARKING

P	A	N	1	7	6	1			H	W	/	S	W			
E	N	W	8	9	8	4	8	A	1	K	F					
Y	Y	W	W	D	L	L										

13.2. MARKING DEFINITION

(1) Pin1 marking

(2) 2D code (Serial number)

(3) Marking:

PAN1761 (Model Name), HW/SW (Hardware/Software version)

ENW89848A1KF (Part Number, refer to chapter 19 Ordering Information)

Lot code (YearYear, WeekWeek, Day, LotLot)

ES (Engineering Sample marking)

Note: For available Software Versions, refer to [1] PAN1761ETU Design-Guide.
and chapter 19 Ordering Information.

14. MECHANICAL REQUIREMENTS

No.	Item	Limit	Condition
1	Solderability	More than 75% of the soldering area shall be coated by solder	Reflow soldering with recommendable temperature profile
2	Resistance to soldering heat	It shall be satisfied electrical requirements and not be mechanical damage	See chapter 10.4

CLASSIFICATION	PRODUCT SPECIFICATION	No. DS-1761-2400-102	REV. 0.5
SUBJECT	CLASS 2 BLUETOOTH LOW ENERGY + NFC SINGLE MODE MODULE	PAGE	17 of 29
CUSTOMER'S CODE PAN1761	PANASONIC'S CODE ENW89848A1KF	DATE	09.06.2016

15. DEVELOPMENT OF APPLICATIONS

For development support please refer to [1] PAN1761ETU Design-Guide.

16. RELIABILITY TESTS

The measurement should be done after being exposed to room temperature and humidity for 1 hour.

No.	Item	Limit	Condition
1	Vibration test	Electrical parameter should be in specification	a) Freq.:10~50Hz,Amplitude:1.5mm a) 20min. / cycle,1hrs. each of XYZ axis b) Freq.:30~100Hz, 6G b) 20min. / cycle,1hrs. each of XYZ axis
2	Shock test	the same as above	Dropped onto hard wood from height of 50cm for 3 times
3	Heat cycle test	the same as above	-40°C for 30min. and +85°C for 30min.; each temperature 300 cycles
4	Moisture test	the same as above	+60°C, 90% RH, 300h
5	Low temp. test	the same as above	-40°C, 300h
6	High temp. test	the same as above	+85°C, 300h

17. CAUTIONS

Failure to follow the guidelines set forth in this document may result in degrading of the product's functions and damage to the product.

17.1. DESIGN NOTES

- (1) Follow the conditions written in this specification, especially the control signals of this module.
- (2) The supply voltage has to be free of AC ripple voltage (for example from a battery or a low noise regulator output). For noisy supply voltages, provide a decoupling circuit (for example a ferrite in series connection and a bypass capacitor to ground of at least 47uF directly at the module).
- (3) This product should not be mechanically stressed when installed.
- (4) Keep this product away from heat. Heat is the major cause of decreasing the life of these products.
- (5) Avoid assembly and use of the target equipment in conditions where the products' temperature may exceed the maximum tolerance.
- (6) The supply voltage should not be exceedingly high or reversed. It should not carry noise and/or spikes.
- (7) Keep this product away from other high frequency circuits.

CLASSIFICATION	PRODUCT SPECIFICATION	No. DS-1761-2400-102	REV. 0.5
SUBJECT	CLASS 2 BLUETOOTH LOW ENERGY + NFC SINGLE MODE MODULE	PAGE	18 of 29
CUSTOMER'S CODE PAN1761	PANASONIC'S CODE ENW89848A1KF	DATE	09.06.2016

17.2. INSTALLATION NOTES

- (1) Reflow soldering is possible twice based on the conditions in chapter 15. Set up the temperature at the soldering portion of this product according to this reflow profile.
- (2) Carefully position the products so that their heat will not burn into printed circuit boards or affect the other components that are susceptible to heat.
- (3) Carefully locate these products so that their temperatures will not increase due to the effects of heat generated by neighboring components.
- (4) If a vinyl-covered wire comes into contact with the products, then the cover will melt and generate toxic gas, damaging the insulation. Never allow contact between the cover and these products to occur.
- (5) This product should not be mechanically stressed or vibrated when reflowed.
- (6) To repair the board by hand soldering, follow the conditions set forth in this chapter.
- (7) Do not wash this product.
- (8) Refer to the recommended pattern when designing a board.
- (9) Pressing on parts of the metal cover or fastening objects to the metal will cause damage to the unit.
- (10) For more details on LGA (Land Grid Array) soldering processes refer to the application note.

17.3. USAGE CONDITIONS NOTES

- (1) Take measures to protect the unit against static electricity. If pulses or other transient loads (a large load applied in a short time) are applied to the products, check and evaluate their operation before assembly on the final products.
- (2) Do not use dropped products.
- (3) Do not touch, damage or soil the pins.
- (4) Follow the recommended condition ratings about the power supply applied to this product.
- (5) Electrode peeling strength: Do not add pressure of more than 4.9N when soldered on PCB.
- (6) Pressing on parts of the metal cover or fastening objects to the metal cover will cause damage.
- (7) These products are intended for general purpose and standard use in general electronic equipment, such as home appliances, office equipment, information and communication equipment.

CLASSIFICATION	PRODUCT SPECIFICATION	No. DS-1761-2400-102	REV. 0.5
SUBJECT	CLASS 2 BLUETOOTH LOW ENERGY + NFC SINGLE MODE MODULE	PAGE	19 of 29
CUSTOMER'S CODE PAN1761	PANASONIC'S CODE ENW89848A1KF	DATE	09.06.2016

17.4. STORAGE NOTES

- (1) The module should not be stressed mechanically during storage.
- (2) Do not store these products in the following conditions or the performance characteristics of the product, such as RF performance will be adversely affected:
 - Storage in salty air or in an environment with a high concentration of corrosive gas, such as Cl₂, H₂S, NH₃, SO₂, or NO_x
 - Storage in direct sunlight
 - Storage in an environment where the temperature may be outside the range of 5°C to 35°C range, or where the humidity may be outside the 45 to 85% range.
 - Storage of the products for more than one year after the date of delivery Storage period: Please check the adhesive strength of the embossed tape and soldering after 6 months of storage.
- (3) Keep this product away from water, poisonous gas and corrosive gas.
- (4) This product should not be stressed or shocked when transported.
- (5) Follow the specification when stacking packed crates (max. 10).

17.5. SAFETY CAUTIONS

These specifications are intended to preserve the quality assurance of products and individual components.

Before use, check and evaluate the operation when mounted on your products. Abide by these specifications, without deviation when using the products. These products may short-circuit. If electrical shocks, smoke, fire, and/or accidents involving human life are anticipated when a short circuit occurs, then provide the following failsafe functions, as a minimum.

- (1) Ensure the safety of the whole system by installing a protection circuit and a protection device.
- (2) Ensure the safety of the whole system by installing a redundant circuit or another system to prevent a single fault causing an unsafe status.

17.6. OTHER CAUTIONS

- (1) This specification sheet is copyrighted. Please do not disclose it to a third party.
- (2) Please do not use the products for other purposes than those listed.
- (3) Be sure to provide an appropriate fail-safe function on your product to prevent an additional damage that may be caused by the abnormal function or the failure of the product.
- (4) This product has been manufactured without any ozone chemical controlled under the Montreal Protocol.
- (5) These products are not intended for other uses, other than under the special conditions shown below. Before using these products under such special conditions, check their performance and reliability under the said special conditions carefully to determine whether or not they can be used in such a manner.
 - In liquid, such as water, salt water, oil, alkali, or organic solvent, or in places where liquid may splash.
 - In direct sunlight, outdoors, or in a dusty environment
 - In an environment where condensation occurs.
 - In an environment with a high concentration of harmful gas (e.g. salty air, HCl,

CLASSIFICATION	PRODUCT SPECIFICATION	No. DS-1761-2400-102	REV. 0.5
SUBJECT	CLASS 2 BLUETOOTH LOW ENERGY + NFC SINGLE MODE MODULE	PAGE	20 of 29
CUSTOMER'S CODE PAN1761	PANASONIC'S CODE ENW89848A1KF	DATE	09.06.2016

Cl₂, SO₂, H₂S, NH₃, and NO_x)

- (6) If an abnormal voltage is applied due to a problem occurring in other components or circuits, replace these products with new products because they may not be able to provide normal performance even if their electronic characteristics and appearances appear satisfactory.
- (7) When you have any question or uncertainty, contact Panasonic.

CLASSIFICATION	PRODUCT SPECIFICATION	No. DS-1761-2400-102	REV. 0.5
SUBJECT	CLASS 2 BLUETOOTH LOW ENERGY + NFC SINGLE MODE MODULE	PAGE	21 of 29
CUSTOMER'S CODE PAN1761	PANASONIC'S CODE ENW89848A1KF	DATE	09.06.2016

18. PACKAGING

If the product has mass production status, indicated in chapter 21, we will deliver the module in the package which are described below.

18.1. PAN1761 TAPE DIMENSION

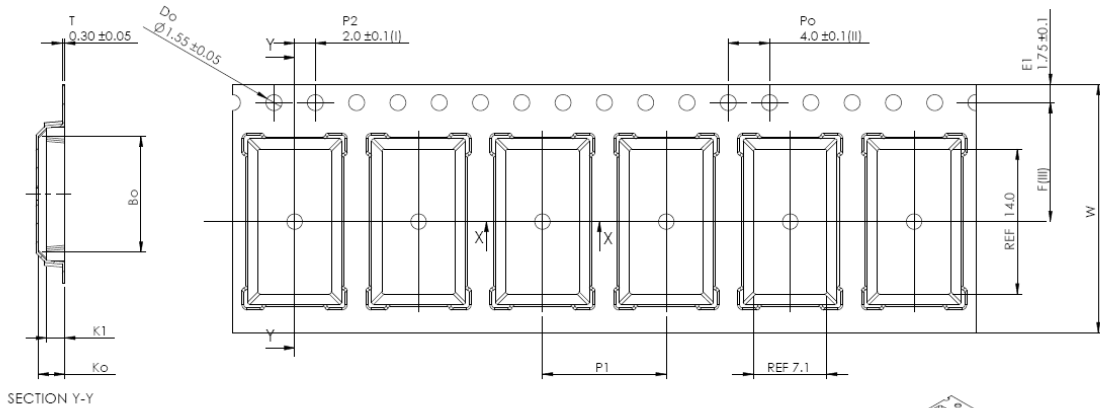

Ao	9.10	+/- 0.1
Bo	16.00	+/- 0.1
Ko	3.20	+/- 0.1
K1	2.20	+/- 0.1
F	11.50	+/- 0.1
P1	12.00	+/- 0.1
W	24.00	+/- 0.3

Forming format : Flatbed
Estimated max. length : 64 meter/22B3 reel

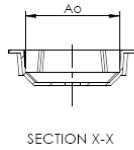

SECTION X-X

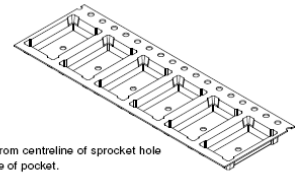

- (I) Measured from centreline of sprocket hole to centreline of pocket.
- (II) Cumulative tolerance of 10 sprocket holes is ± 0.20 .
- (III) Measured from centreline of sprocket hole to centreline of pocket.
- (IV) Other material available.

ALL DIMENSIONS IN MILLIMETRES UNLESS OTHERWISE STATED.

CLASSIFICATION	PRODUCT SPECIFICATION	No. DS-1761-2400-102	REV. 0.5
SUBJECT	CLASS 2 BLUETOOTH LOW ENERGY + NFC SINGLE MODE MODULE	PAGE	22 of 29
CUSTOMER'S CODE PAN1761	PANASONIC'S CODE ENW89848A1KF	DATE	09.06.2016

18.2. PACKING IN TAPE

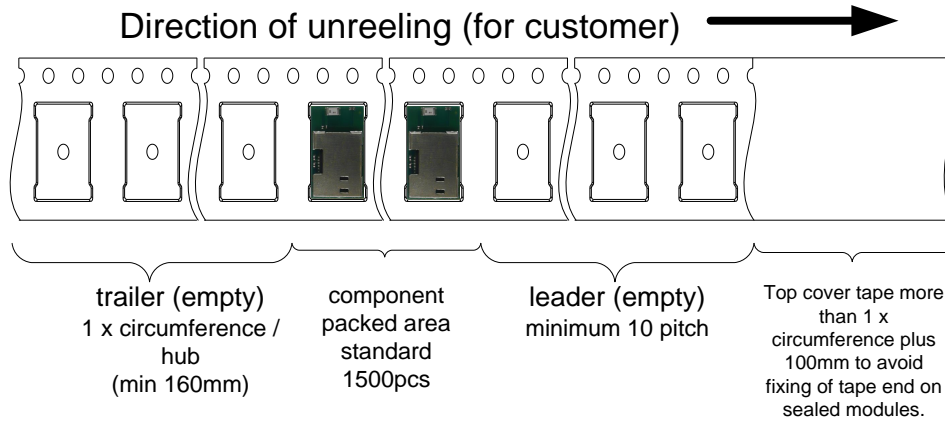

Empty spaces in component packed area shall be less than two per reel and those spaces shall not be consecutive.

Top cover tape shall not be found on reel holes and shall not stick out from reel.

18.3. COMPONENT DIRECTION

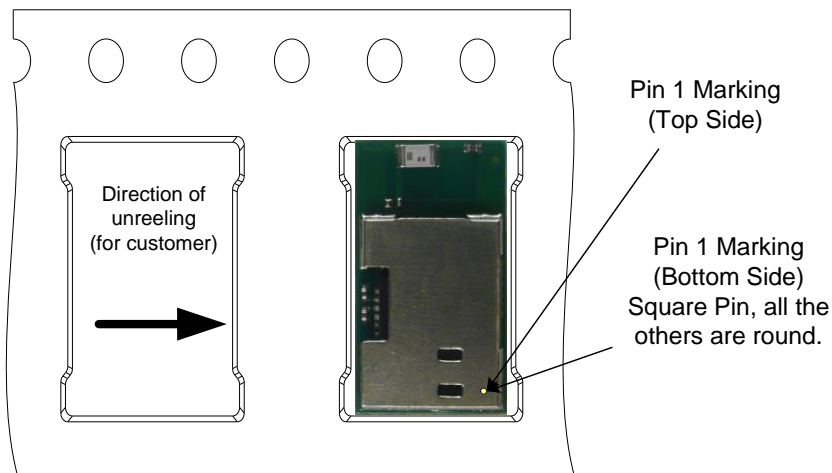

18.4. REEL DIMENSION

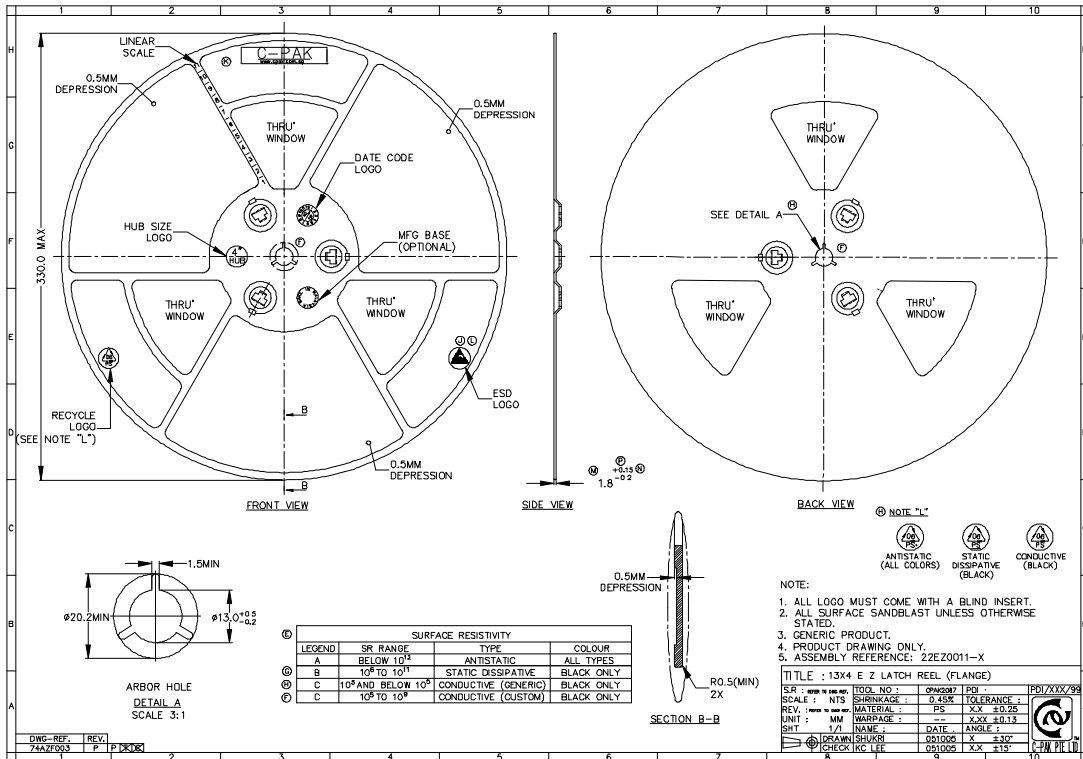

CLASSIFICATION	PRODUCT SPECIFICATION	No. DS-1761-2400-102	REV. 0.5
SUBJECT	CLASS 2 BLUETOOTH LOW ENERGY + NFC SINGLE MODE MODULE	PAGE	24 of 29
CUSTOMER'S CODE PAN1761	PANASONIC'S CODE ENW89848A1KF	DATE	09.06.2016

18.5. LABEL FOR PACKAGE

The picture shows an example from similar product.

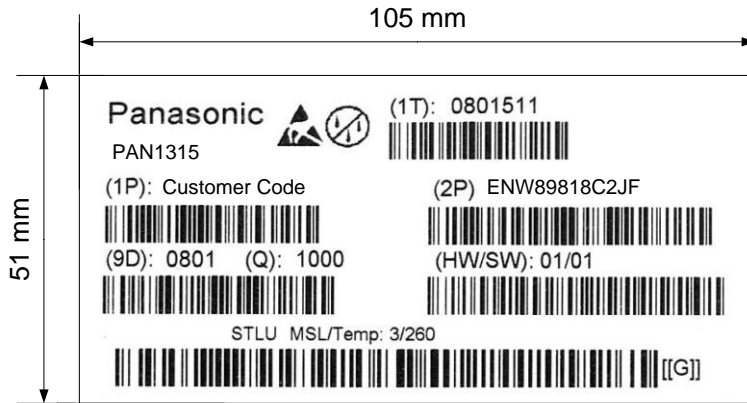

(1T)	Lot code [YYWWDLL]	Example from above:
	YY year	printed 08
	WW normal calendar week	printed 01
	D day	printed 5 (Friday)
	L line identifier, if more as one	printed 1
	L lot identifier per day	printed 1
(1P)	Customer Order Code, if any, otherwise company name will be printed	
(2P)	Panasonic Order Code: ENW89848A1KF	
(9D)	Date code as [YYWW]	
(Q)	Quantity [XXXX], variable max. 1500	
(HW/SW)	Hardware /Software Release	
	Hardware 01 Indicates the HW revision.	
	Software 01 Indicates the SW revision.	

18.6. TOTAL PACKAGE

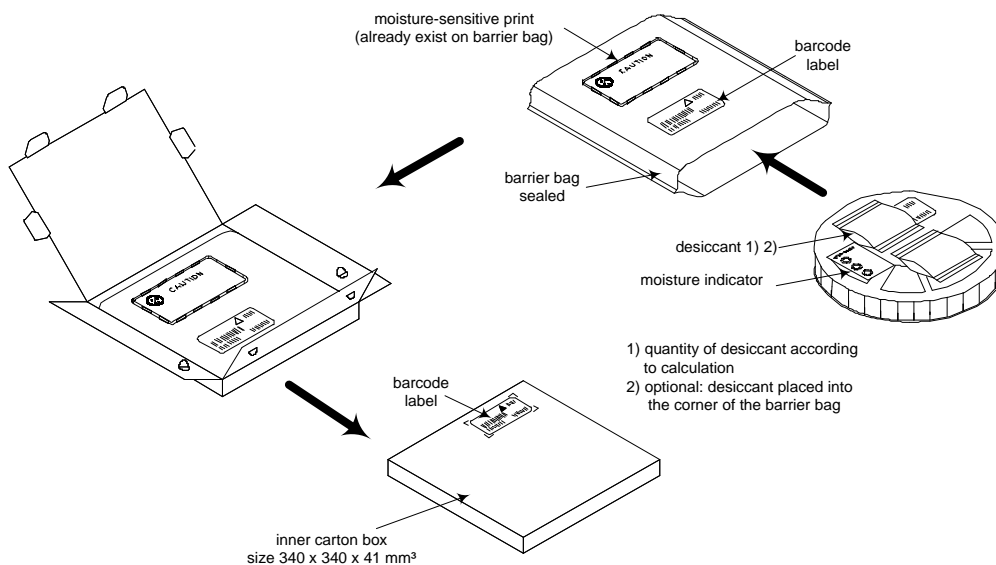

CLASSIFICATION	PRODUCT SPECIFICATION	No. DS-1761-2400-102	REV. 0.5
SUBJECT	CLASS 2 BLUETOOTH LOW ENERGY + NFC SINGLE MODE MODULE	PAGE	25 of 29
CUSTOMER'S CODE PAN1761	PANASONIC'S CODE ENW89848A1KF	DATE	09.06.2016

19. ORDERING INFORMATION

Ordering part number	Description	MOQ ⁽¹⁾
ENW89848A1KF ⁽²⁾	PAN1761 CLASS 2 Bluetooth single mode Module according BT-4.0. <i>Bluetooth® smart device</i>	1500

Notes:

- (1) Abbreviation for Minimum Order Quantity (MOQ). The standard MOQ for mass production is 1500 pieces, fewer only on customer demand. Samples for evaluation can be delivered at any quantity via the distribution channels.
- (2) Samples are available on customer demand.

20. ROHS AND REACH DECLARATION

Hereby we declare to our best present knowledge based on declaration of our suppliers that this product follows the latest official RoHS and REACH Directive.

For the most updated one, please refer to [3].

21. DATA SHEET STATUS

This data sheet contains the preliminary specification.

Panasonic reserves the right to make changes at any time without notice in order to improve design and supply the best possible product.

Please consult the most recently issued data sheet before initiating or completing a design.

22. HISTORY FOR THIS DOCUMENT

Revision	Date	Modification / Remarks
0.1	November 2015	1 st preliminary version.
0.2	January 2016	PIN Table correction.
0.3	February 2016	Minor changes.

CLASSIFICATION	PRODUCT SPECIFICATION	No. DS-1761-2400-102	REV. 0.5
SUBJECT	CLASS 2 BLUETOOTH LOW ENERGY + NFC SINGLE MODE MODULE	PAGE	26 of 29
CUSTOMER'S CODE PAN1761	PANASONIC'S CODE ENW89848A1KF	DATE	09.06.2016

23. RELATED DOCUMENTS

For an update, please search in the suitable homepage.

- [1] PAN1761ETU Design-Guide
<http://www.pideu.panasonic.de>
- [2] Application Note Land Grid Array
<http://www.pideu.panasonic.de/pdf/184ext.pdf>
- [3] Toshiba Product Page – General information
<http://toshiba.semicon-storage.com/eu/product/wireless-communication/bluetooth.html>
- [4] Toshiba SDK and Developer Zone
<https://apps.toshiba.de/web/SDKRegistration/>
- [5] REACH and RoHS Certificate
<http://www.pideu.panasonic.de/pdf/182ext2.jpg>

CLASSIFICATION	PRODUCT SPECIFICATION	No. DS-1761-2400-102	REV. 0.5
SUBJECT	CLASS 2 BLUETOOTH LOW ENERGY + NFC SINGLE MODE MODULE	PAGE	27 of 29
CUSTOMER'S CODE PAN1761	PANASONIC'S CODE ENW89848A1KF	DATE	09.06.2016

24. RADIATION PATTERN OF ANTENNA

[Tr] S11 Log Mag 10.00dB/ Ref 0.000dB [F2 Del]

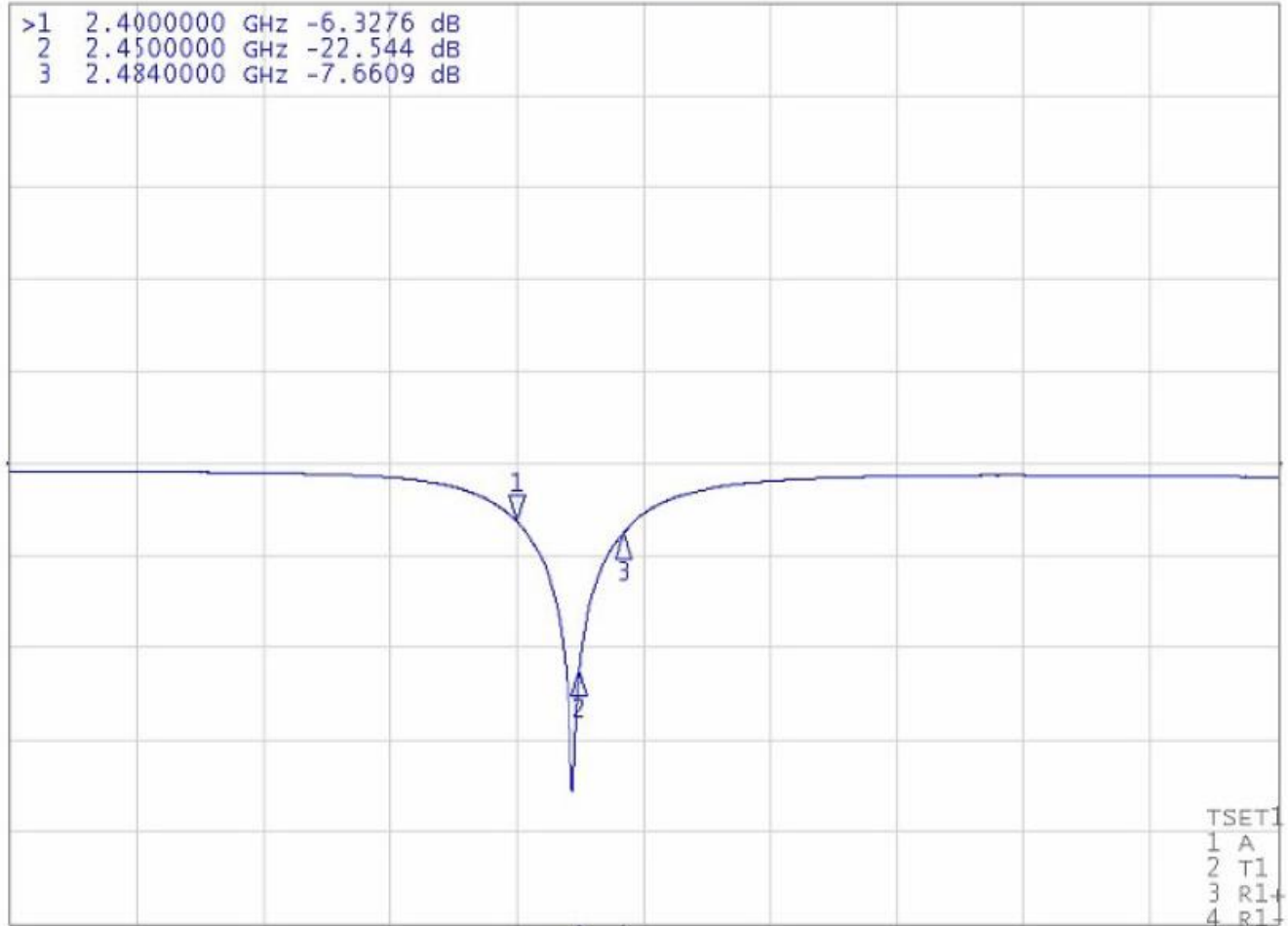

CLASSIFICATION	PRODUCT SPECIFICATION	No. DS-1761-2400-102	REV. 0.5
SUBJECT	CLASS 2 BLUETOOTH LOW ENERGY + NFC SINGLE MODE MODULE	PAGE	28 of 29
CUSTOMER'S CODE PAN1761	PANASONIC'S CODE ENW89848A1KF	DATE	09.06.2016

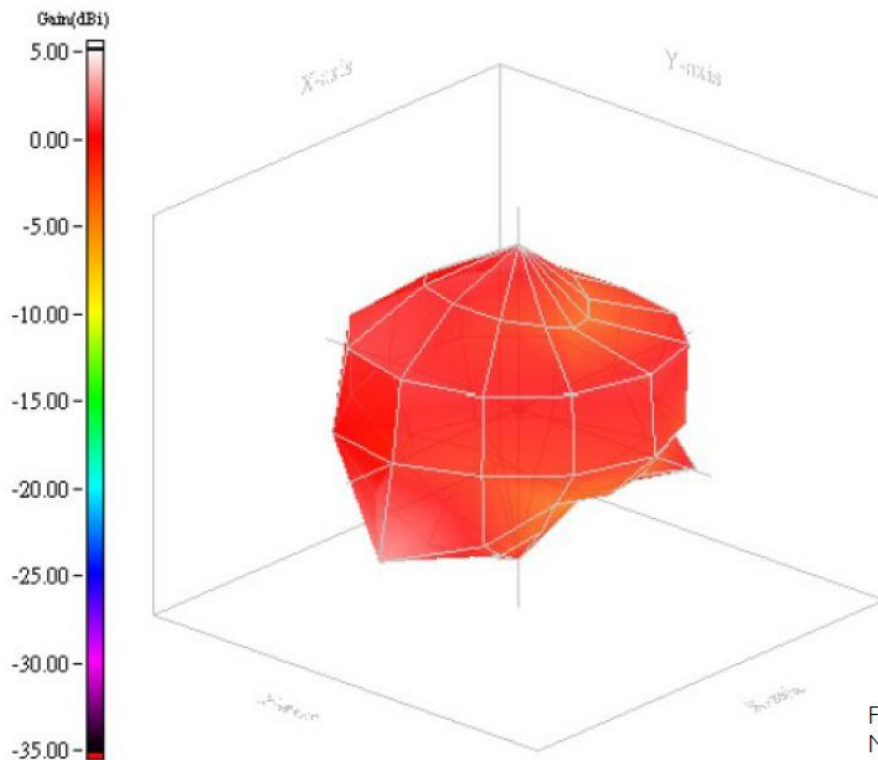

Frequency= 2.45 GHz
 Max gain = 2.72dBi, at (120,0)
 MEG (mean effective gain)= -0.69 dBi
 Directivity (dB) = 3.88
 Efficiency = -1.16dB, 76.56 %

CLASSIFICATION	PRODUCT SPECIFICATION	No. DS-1761-2400-102	REV. 0.5
SUBJECT	CLASS 2 BLUETOOTH LOW ENERGY + NFC SINGLE MODE MODULE	PAGE	29 of 29
CUSTOMER'S CODE PAN1761	PANASONIC'S CODE ENW89848A1KF	DATE	09.06.2016

25. GENERAL INFORMATION

© Panasonic Industrial Devices Europe GmbH 2012.

All rights reserved.

This product description does not lodge the claim to be complete and free of mistakes.

Please contact the related product manager in every case.

If we deliver ES samples to the customer, these samples have the status Engineering Samples. This means, the design of this product is not yet concluded. Engineering Samples may be partially or fully functional, and there may be differences to be published Data Sheet.

Engineering Samples are not qualified and are not to be used for reliability testing or series production.

Disclaimer:

Customer acknowledges that samples may deviate from the Data Sheet and may bear defects due to their status of development and the lack of qualification mentioned above.

Panasonic rejects any liability or product warranty for Engineering Samples. In particular, Panasonic disclaims liability for damages caused by

- the use of the Engineering Sample other than for Evaluation Purposes, particularly the installation or integration in an other product to be sold by Customer,
- deviation or lapse in function of Engineering Sample,
- improper use of Engineering Samples.

Panasonic disclaims any liability for consequential and incidental damages.

In case of any questions, please contact your local sales partner or the related product manager.

26. LIFE SUPPORT POLICY

This Panasonic product is not designed for use in life support appliances, devices, or systems where malfunction can reasonably be expected to result in a significant personal injury to the user, or as a critical component in any life support device or system whose failure to perform can be reasonably expected to cause the failure of the life support device or system, or to affect its safety or effectiveness. Panasonic customers using or selling these products for use in such applications do so at their own risk and agree to fully indemnify Panasonic for any damages resulting.