

San Ace C270 9B1TP type

Bracket-mounted Centrifugal Fans

Features

Maximizes Strengths of the Centrifugal Fan

To maximize fan performance, an air inlet needs to be precisely mounted to the fan. Bracket-mounted centrifugal fan has an air inlet and a mounting bracket integrated in one unit. The precise assembly at factory ensures the optimized balance, helping the fan perform at its maximum potential.

Easy Installation

Centrifugal fan comes equipped with an air inlet and a mounting bracket, making your installation work easy.



270 × 270 × 99 mm

Specifications

The following nos. have **PWM controls and pulse sensors**.

Model no.	Rated voltage [V]	Operating voltage range [V]	PWM duty cycle (Note 1, 2) [%]	Rated current [A]	Rated input [W]	Rated speed [min ⁻¹]	Max. airflow [m ³ /min] [CFM]	Max. static pressure [Pa] [inchH ₂ O]	SPL [dB(A)]	Operating temperature [°C]	Expected life [h]
9B1TP24P0H001	24	16 to 36	100	3.2	76.8	3,050	17.6 622	530 2.13	71	-20 to +70	40,000 / 60°C (70,000 / 40°C)
			15	0.4	9.6	1,000	5.75 203	57.4 0.23	53		
9B1TP48P0G001	48	36 to 72	100	2.75	132	3,650	21.0 742	760 3.05	74	-20 to +60	
			15	0.2	9.6	1,000	5.75 203	57.4 0.23	53		
9B1TP48P0H001			100	1.6	76.8	3,050	17.6 622	530 2.13	71	-20 to +70	
			15	0.2	9.6	1,000	5.75 203	57.4 0.23	53		

Note 1 PWM frequency: 25 kHz

Note 2 Fans do not rotate when PWM duty cycle is 0%.

Note 3 Max input is 9B1TP24P0H001 / 9B1TP48P0H001: 160 W, 9B1TP48P0G001: 280 W at rated voltage.

Models with the following sensor specifications are also available as options: **Without Sensor**

Common Specifications

- Material Motor case: Aluminum, Impeller: Plastics (Flammability: UL94V-0), Bracket: Aluminum, Plastics (Flammability: UL94V-0)
- Expected life Refer to specifications
(L10: Survival rate: 90% at 60 °C, rated voltage, and continuously run in a free air state)
- Motor protection system Current blocking function and reverse polarity protection
- Dielectric strength 50 / 60 Hz, 500 VAC, 1 minute (between lead conductor and bracket)
- Sound pressure level (SPL) Expressed as the value at 1 m from air inlet side
- Operating temperature Refer to specifications (Non-condensing)
- Storage temperature -30 °C to +70 °C (Non-condensing)
- Lead wire ⊕Red ⊖Black Sensor: Yellow Control: Brown
- Mass Approx. 1,700 g

Airflow - Static Pressure Characteristics

- PWM duty cycle

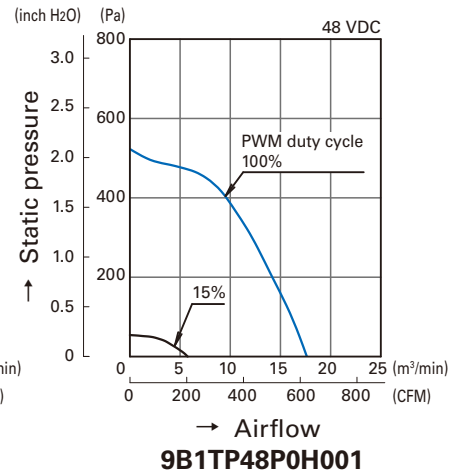
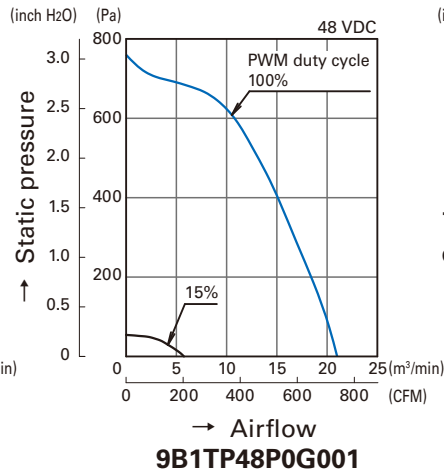
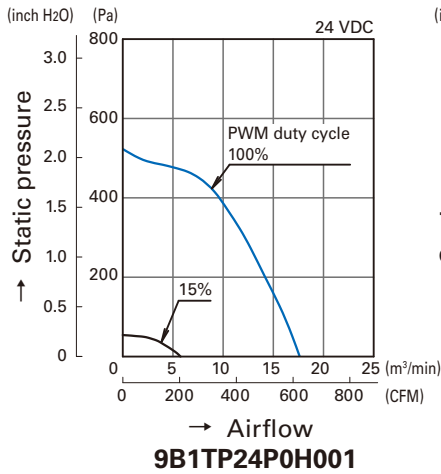

- Operating voltage range

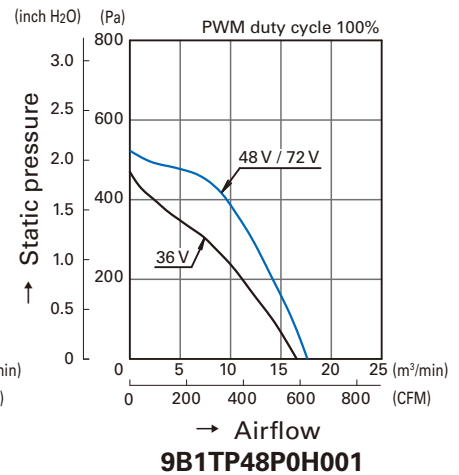
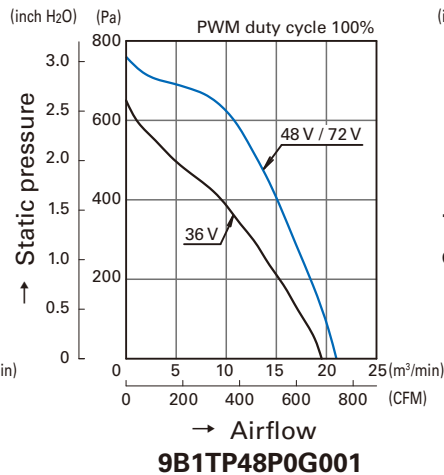
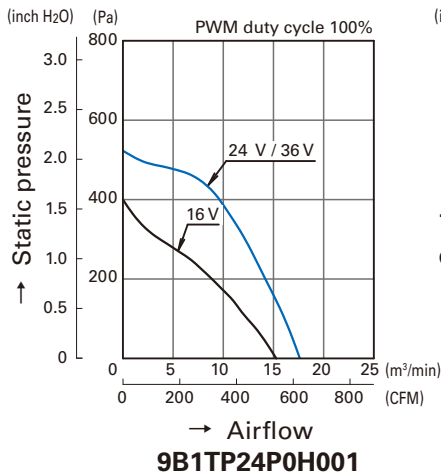

PWM Duty - Speed Characteristics Example

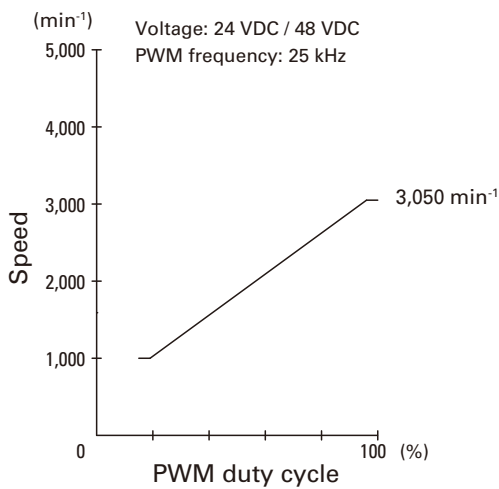

**9B1TP24P0H001
9B1TP48P0H001**

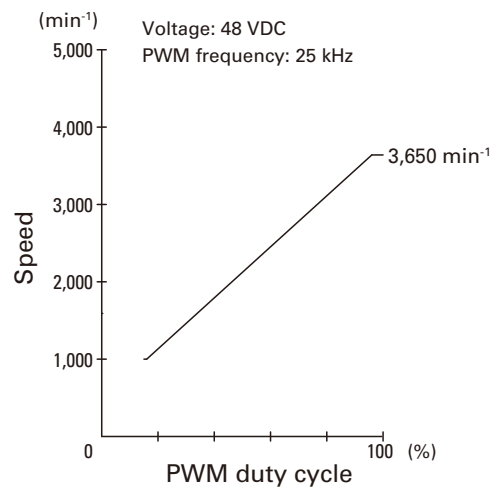

9B1TP48P0G001

PWM Input Signal Example

Input signal waveform

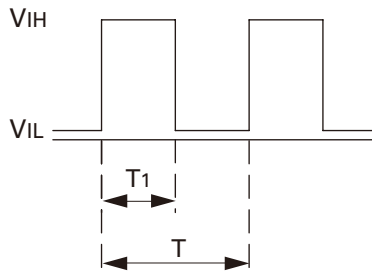

$V_{IH}=4.75\text{ V to }5.25\text{ V}$

$V_{IL}=0\text{ V to }0.4\text{ V}$

$$\text{PWM duty cycle (\%)} = \frac{T_1}{T} \times 100$$

$$\text{PWM frequency } 25\text{ (kHz)} = \frac{1}{T}$$

Source current (I_{source}) : 1 mA max. at control voltage 0 V

Sink current (I_{sink}) : 1 mA max. at control voltage 5.25 V

Control terminal voltage: 5.25 V max. (Open circuit)

When the control lead wire is open, the fan speed is the same as the one at a PWM duty cycle of 100%.

Either TTL input, open collector or open drain can be used for PWM control input signal.

Example of Connection Schematic

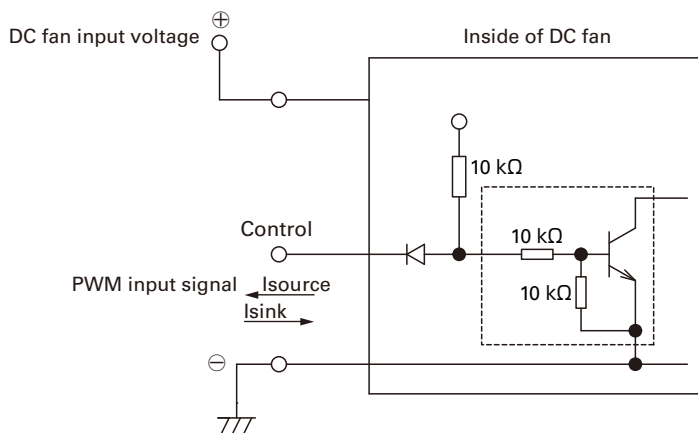

Specifications for Pulse Sensors

Output circuit: Open collector

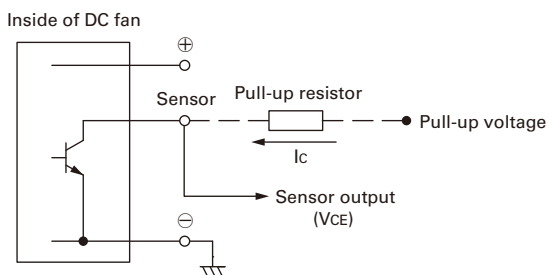

Rated Voltage 24 V Fan

$V_{CE}=+36\text{ VDC max.}$

$I_c=10\text{ mA max. [}V_{CE}\text{ (SAT)}=1\text{ V max.]}$

Rated Voltage 48 V Fan

$V_{CE}=+72\text{ VDC max.}$

$I_c=10\text{ mA max. [}V_{CE}\text{ (SAT)}=1\text{ V max.]}$

Output waveform (Need pull-up resistor)

In case of steady running

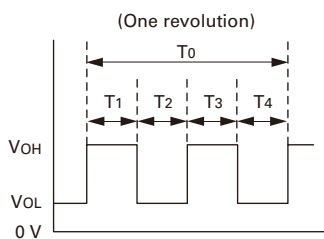

$$T_1 \text{ to } 4 \cong (1/4) T_0$$

$$T_1 \text{ to } 4 \cong (1/4) T_0=60/4N\text{ (sec)}$$

$$N=\text{Fan speed (min}^{-1}\text{)}$$

Dimensions (unit: mm)

Fan

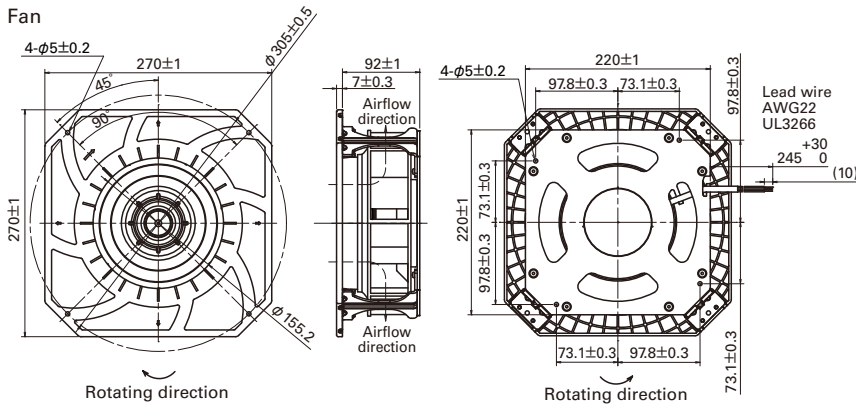

Finger guard (Model: 109-1146)

Surface treatment: Nickel-chrome plating
(Color: silver)

Mass: 106 g

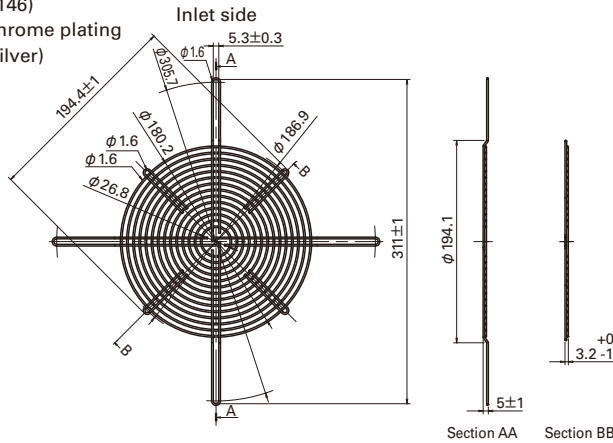

Reference Dimensions of Mounting Holes and Vent Opening (unit: mm)

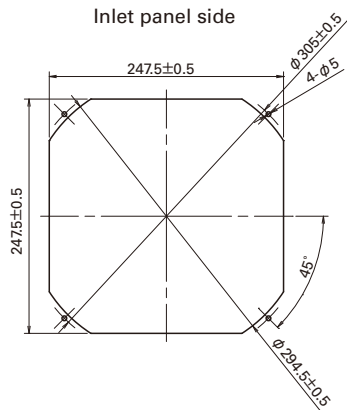

Reference Diagram for Mounting

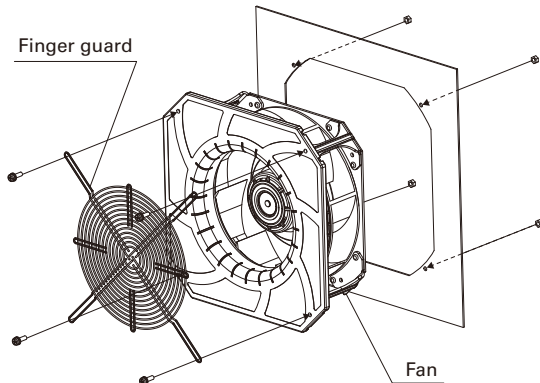

Notice

- Please read the "Safety Precautions" on our website before using the product.
- The products shown in this catalog are subject to Japanese Export Control Law. Diversion contrary to the law of exporting country is prohibited.
- For protecting fan bearings against electrolytic corrosion near strong electromagnetic noise sources, we provide effective countermeasures such as Electrolytic Corrosion Proof Fans and EMC guards. Contact us for details.

SANYO DENKI CO.,LTD. 3-33-1 Minami-Otsuka, Toshima-ku, Tokyo 170-8451, Japan TEL: +81 3 5927 1020

<http://www.sanyodenki.com>

The names of companies and/or their products specified in this catalog are the trade names, and/or trademarks and/or registered trademarks of such respective companies. "San Ace" is a trademark of SANYO DENKI CO.,LTD.

Specifications are subject to change without notice.

CATALOG No. C1064B001 '16.8