



Is Now Part of



ON Semiconductor®

To learn more about ON Semiconductor, please visit our website at
www.onsemi.com

ON Semiconductor and the ON Semiconductor logo are trademarks of Semiconductor Components Industries, LLC dba ON Semiconductor or its subsidiaries in the United States and/or other countries. ON Semiconductor owns the rights to a number of patents, trademarks, copyrights, trade secrets, and other intellectual property. A listing of ON Semiconductor's product/patent coverage may be accessed at www.onsemi.com/site/pdf/Patent-Marking.pdf. ON Semiconductor reserves the right to make changes without further notice to any products herein. ON Semiconductor makes no warranty, representation or guarantee regarding the suitability of its products for any particular purpose, nor does ON Semiconductor assume any liability arising out of the application or use of any product or circuit, and specifically disclaims any and all liability, including without limitation special, consequential or incidental damages. Buyer is responsible for its products and applications using ON Semiconductor products, including compliance with all laws, regulations and safety requirements or standards, regardless of any support or applications information provided by ON Semiconductor. "Typical" parameters which may be provided in ON Semiconductor data sheets and/or specifications can and do vary in different applications and actual performance may vary over time. All operating parameters, including "Typicals" must be validated for each customer application by customer's technical experts. ON Semiconductor does not convey any license under its patent rights nor the rights of others. ON Semiconductor products are not designed, intended, or authorized for use as a critical component in life support systems or any FDA Class 3 medical devices or medical devices with a same or similar classification in a foreign jurisdiction or any devices intended for implantation in the human body. Should Buyer purchase or use ON Semiconductor products for any such unintended or unauthorized application, Buyer shall indemnify and hold ON Semiconductor and its officers, employees, subsidiaries, affiliates, and distributors harmless against all claims, costs, damages, and expenses, and reasonable attorney fees arising out of, directly or indirectly, any claim of personal injury or death associated with such unintended or unauthorized use, even if such claim alleges that ON Semiconductor was negligent regarding the design or manufacture of the part. ON Semiconductor is an Equal Opportunity/Affirmative Action Employer. This literature is subject to all applicable copyright laws and is not for resale in any manner.

FL6961

Single-Stage Flyback and Boundary Mode PFC Controller for Lighting

Features

- Boundary Mode PFC Controller
- Low Input Current THD
- Controlled On-Time PWM
- Zero-Current Detection
- Cycle-by-Cycle Current Limiting
- Leading-Edge Blanking Instead of RC Filtering
- Low Startup Current: 10 μ A Typical
- Low Operating Current: 4.5mA Typical
- Feedback Open-Loop Protection
- Programmable Maximum On-Time (MOT)
- Output Over-Voltage Clamping Protection
- Clamped Gate Output Voltage: 16.5V

Applications

- General LED Lighting
- Industrial, Commercial and Residential Fixtures
- Outdoor Lighting: Street, Roadway, Parking, Construction, and Ornamental LED Lighting

Description

The FL6961 is a general lighting power controller for low- to high-power lumens applications requiring power factor correction. It is designed for flyback or boost converter operating in Boundary Mode.

The FL6961 provides a controlled on-time to regulate the output DC voltage and achieves natural power factor correction (PFC). The maximum on-time of the external switch is programmable to ensure safe operation during AC brownouts. An innovative multi-vector error amplifier provides rapid transient response and precise output voltage clamping. A built-in circuit disables the controller if the output feedback loop is opened. The startup current is lower than 20 μ A and the operating current is less than 6mA. The supply voltage can be up to 25V, maximizing application flexibility.

Ordering Information

Part Number	Operating Temperature Range	Package	Packing Method
FL6961MY	-40°C to +125°C	8-Pin, Small Outline Package (SOP)	Tape & Reel

Application Diagram

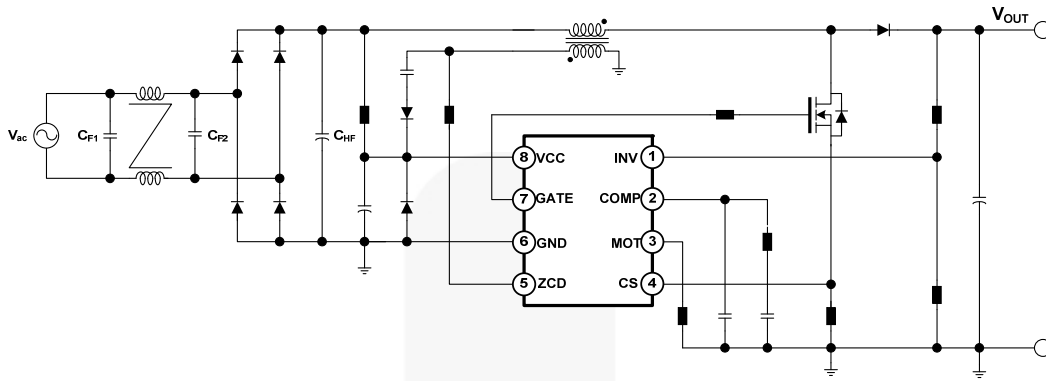

Figure 1. Typical Application Circuit for Step-up Converter

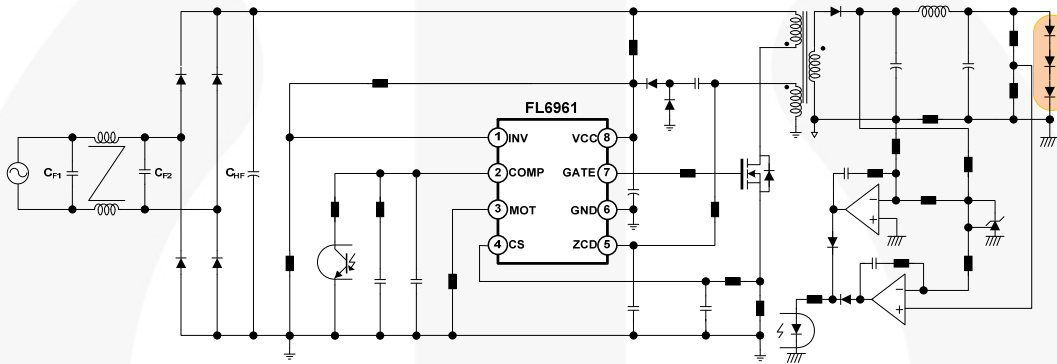

Figure 2. Typical Application Circuit for Single Stage PFC Converter

Block Diagram

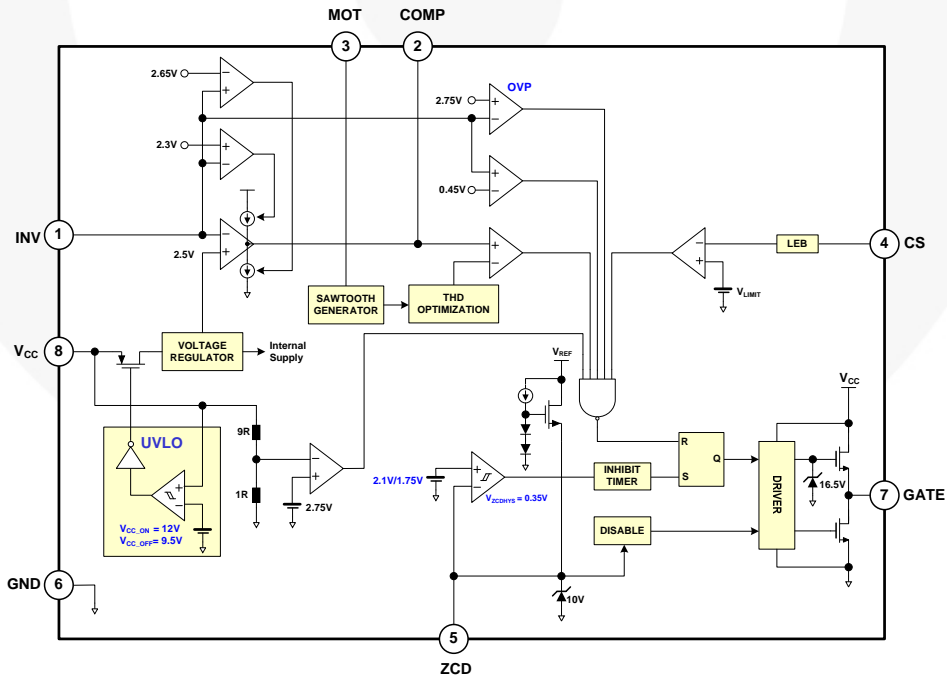
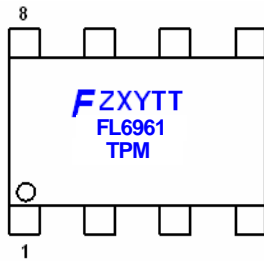

Figure 3. Function Block Diagram

Marking Information



F- Fairchild Logo
 Z- Plant Code
 X- Year Code
 Y- Week Code
 TT: Die Run Code
 T: Package Type (M=SOP)
 P: Z: Pb Free Y: Green Compound
 M: Manufacture Flow Code

Figure 4. Marking Information

Pin Configuration

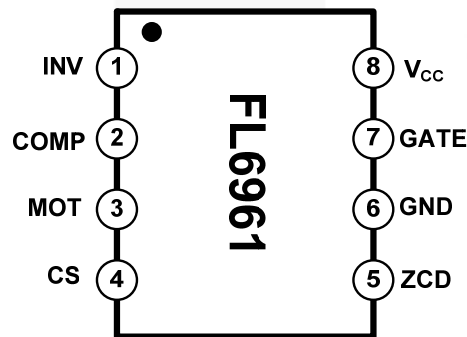

Figure 5. Pin Configuration (Top View)

Pin Definitions

Pin #	Name	Description
1	INV	Inverting Input of the Error Amplifier. INV is connected to the converter output via a resistive divider. This pin is also used for over-voltage clamping and open-loop feedback protection.
2	COMP	Output of the Error Amplifier. To create a precise clamping protection, a compensation network between this pin and GND is suggested.
3	MOT	Maximum On Time. A resistor from MOT to GND is used to determine the maximum on-time of the external power MOSFET. The maximum output power of the converter is a function of the maximum on-time.
4	CS	Current Sense. Input to the over-current protection comparator. When the sensed voltage across the sense resistor reaches the internal threshold (0.8V), the switch is turned off to activate cycle-by-cycle current limiting.
5	ZCD	Zero-Current Detection. This pin is connected to an auxiliary winding via a resistor to detect the zero crossing of the switch current. When the zero crossing is detected, a new switching cycle is started. If it is connected to GND, the device is disabled.
6	GND	Ground. The power ground and signal ground. Placing a 0.1μF decoupling capacitor between V _{CC} and GND is recommended.
7	GATE	Driver Output. Totem-pole driver output to drive the external power MOSFET. The clamped gate output voltage is 16.5V.
8	V _{CC}	Power Supply. Driver and control circuit supply voltage.

Absolute Maximum Ratings

Stresses exceeding the absolute maximum ratings may damage the device. The device may not function or be operable above the recommended operating conditions and stressing the parts to these levels is not recommended. In addition, extended exposure to stresses above the recommended operating conditions may affect device reliability. The absolute maximum ratings are stress ratings only. All voltage values, except differential voltage, are given with respect to GND pin.

Symbol	Parameter	Min.	Max.	Unit
V _{VCC}	DC Supply Voltage		30	V
V _{HIGH}	Gate Driver	-0.3	30.0	V
V _{LOW}	Others (INV, COMP, MOT, CS)	-0.3	7.0	V
V _{ZCD}	Input Voltage to ZCD Pin	-0.3	12.0	V
P _D	Power Dissipation		660	mW
T _J	Operating Junction Temperature	-40	+150	°C
θ _{JA}	Thermal Resistance (Junction-to-Air)		150	°C/W
θ _{JC}	Thermal Resistance (Junction-to-Case)		39	°C/W
T _{STG}	Storage Temperature Range	-65	+150	°C
T _L	Lead Temperature (Wave Soldering or IR, 10 Seconds)		+230	°C
ESD	Human Body Model: JESD22-A114		2.5	KV
	Machine Model: JESD22-A115		200	V

Recommended Operating Conditions

The Recommended Operating Conditions table defines the conditions for actual device operation. Recommended operating conditions are specified to ensure optimal performance to the datasheet specifications. Fairchild does not recommend exceeding them or designing to Absolute Maximum Ratings.

Symbol	Parameter	Min.	Typ.	Max.	Unit
T _A	Operating Ambient Temperature	-40		+125	°C

Electrical Characteristics

Unless otherwise noted, $V_{CC}=15V$ and $T_J=-40^{\circ}C$ to $150^{\circ}C$. Current is defined as positive into the device and negative out of the device.

Symbol	Parameter	Conditions	Min.	Typ.	Max.	Units
V_{CC} Section						
V _{CC-OP}	Continuous Operation Voltage				24.5	V
V _{CC-ON}	Turn-On Threshold Voltage		11.5	12.5	13.5	V
V _{CC-OFF}	Turn-Off Threshold Voltage		8.5	9.5	10.5	V
I _{CC-ST}	Startup Current	$V_{CC}=V_{CC-ON} - 0.16V$		10	20	μA
I _{CC-OP}	Operating Supply Current	$V_{CC}=12V, V_{CS}=0V, C_L=3nF, f_{SW}=60KHz$		4.5	6	mA
V _{CC-OVP}	V _{DD} Over-Voltage Protection Level		26.8	27.8	28.8	V
t _{D-VCCOVP}	V _{DD} Over-Voltage Protection Debounce			30		μs
Error Amplifier Section						
V _{REF}	Reference Voltage		2.475	2.500	2.525	V
G _m	Transconductance			125		μmho
V _{INVH}	Clamp High Feedback Voltage			2.65	2.70	V
V _{INVL}	Clamp Low Feedback Voltage		2.25	2.30		V
V _{OUT-HIGH}	Output High Voltage		4.8			V
V _{OZ}	Zero Duty Cycle Output Voltage		1.15	1.25	1.35	V
V _{INV-OVP}	Over-Voltage Protection for INV Input		2.70	2.75	2.80	V
V _{INV-UVP}	Under-Voltage Protection for INV Input		0.40	0.45	0.50	V
I _{COMP}	Source Current	$V_{INV}=2.35V, V_{COMP}=1.5V$	10	20		μA
	Sink Current	$V_{INV}=1.5V$	550	800		
		$V_{INV}=2.65V, V_{COMP}=5V$	10	20		
Current-Sense Section						
V _{PK}	Threshold Voltage for Peak Current Limit Cycle-by-Cycle Limit		0.77	0.82	0.87	V
t _{PD}	Propagation Delay				200	ns
t _{LEB}	Leading-Edge Blanking Time	$R_{MOT}=24k\Omega, V_{COMP}=5V$		400	500	ns
		$R_{MOT}=24k\Omega, V_{COMP}=V_{OZ}+50mV$		270	350	
Gate Section						
V _{Z-OUT}	Output Voltage Maximum (Clamp)	$V_{CC}=25V$	14.5	16.0	17.5	V
V _{OL}	Output Voltage Low	$V_{CC}=15V, I_O=100mA$			1.4	V
V _{OH}	Output Voltage High	$V_{CC}=14V, I_O=100mA$	8			V
t _R	Rising Time	$V_{CC}=12V, C_L=3nF, 20\sim 80\%$		80		ns
t _F	Falling Time	$V_{CC}=12V, C_L=3nF, 80\sim 20\%$		40		ns

Continued on the following page...

Electrical Characteristics

Unless otherwise noted, $V_{CC}=15V$ and $T_J=-40^{\circ}C$ to $150^{\circ}C$. Current is defined as positive into the device and negative out of the device.

Symbol	Parameter	Conditions	Min.	Typ.	Max.	Units
Zero-Current Detection Section						
V_{ZCD}	Input Threshold Voltage Rising Edge	V_{ZCD} Increasing	1.9	2.1	2.3	V
H_{YS} of V_{ZCD}	Threshold Voltage Hysteresis	V_{ZCD} Decreasing		0.35		V
$V_{ZCD-HIGH}$	Upper Clamp Voltage	$I_{ZCD}=3mA$			12	V
$V_{ZCD-LOW}$	Lower Clamp Voltage	$I_{ZCD}=-1.5mA$	0.3			V
t_{DEAD}	Maximum Delay, ZCD to Output Turn-On	$V_{COMP}=5V$, $f_{SW}=60KHz$	100		400	ns
$t_{RESTART}$	Restart Time	Output Turned Off by ZCD	300	500	700	μs
t_{INHIB}	Inhibit Time (Maximum Switching Frequency Limit)	$R_{MOT}=24k\Omega$		2.8		μs
V_{DIS}	Disable Threshold Voltage		130	200	250	mV
$t_{ZCD-DIS}$	Disable Function Debounce Time	$R_{MOT}=24k\Omega$, $V_{ZCD}=100mV$	800			μs
Maximum On Time Section						
V_{MOT}	Maximum On Time Voltage		1.25	1.30	1.35	V
t_{ON-MAX}	Maximum On Time Programming (Resistor Based)	$R_{MOT}=24k\Omega$, $V_{CS}=0V$, $V_{COMP}=5V$		25		μs

Typical Performance Characteristics

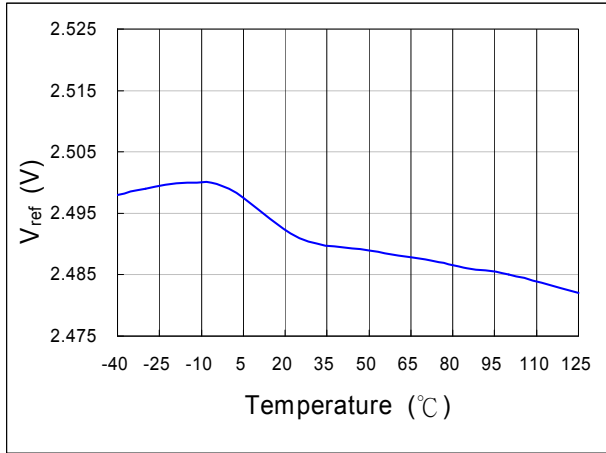

Figure 6. V_{REF} vs. T_A

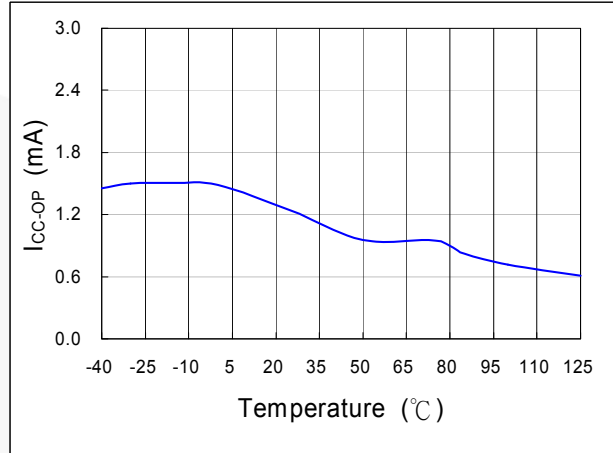

Figure 7. I_{CC-OP} vs. T_A

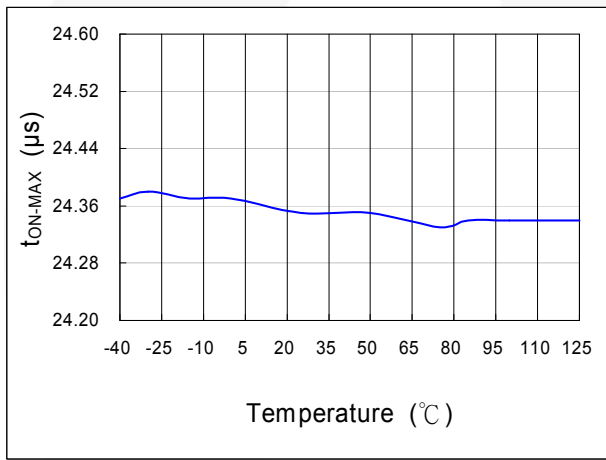

Figure 8. t_{ON-MAX} vs. T_A

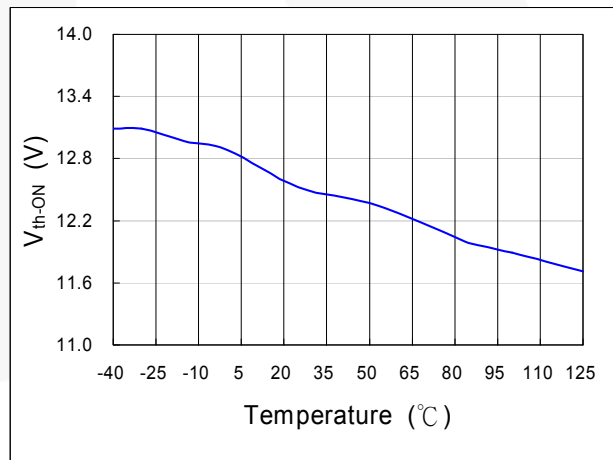

Figure 9. V_{th-ON} vs. T_A

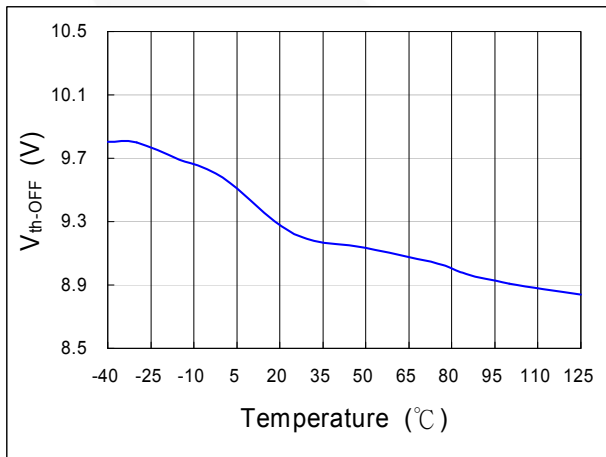

Figure 10. V_{th-OFF} vs. T_A

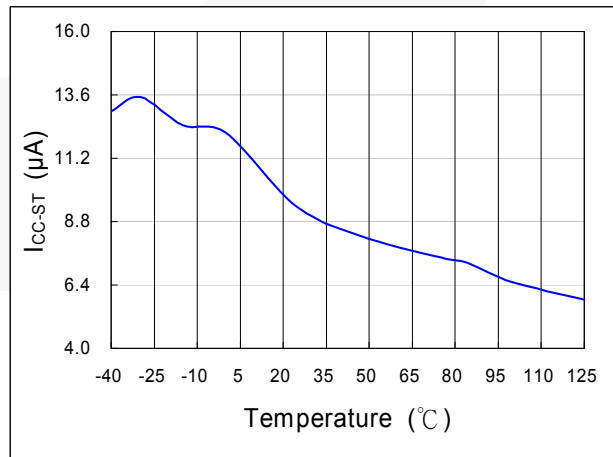

Figure 11. I_{CC-ST} vs. T_A

Typical Performance Characteristics (Continued)

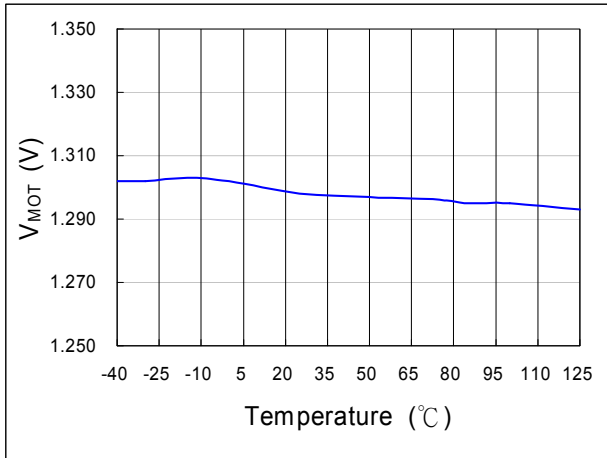

Figure 12. V_{MOT} vs. T_A

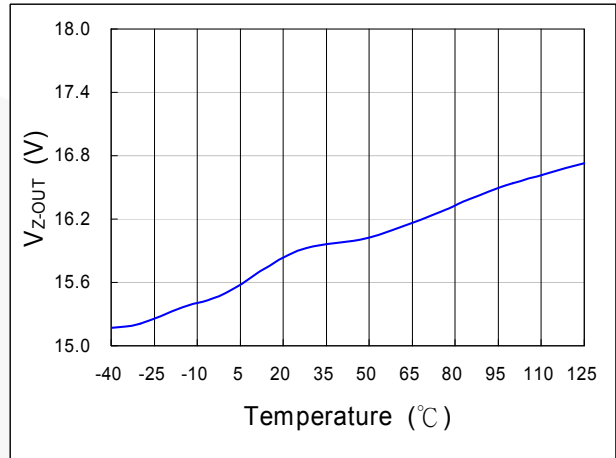

Figure 13. V_{Z-OUT} vs. T_A

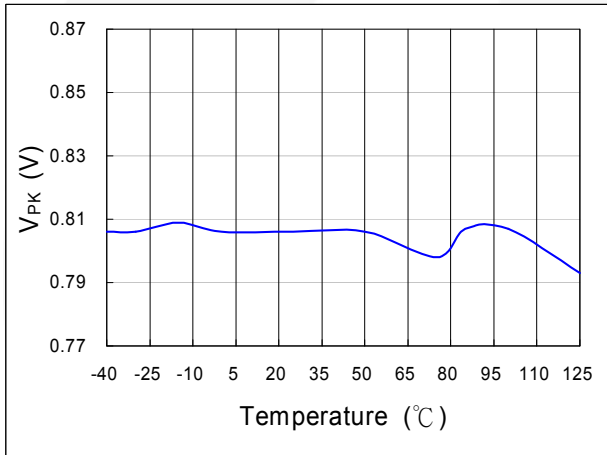

Figure 14. V_{PK} vs. T_A

Functional Description

Error Amplifier

The inverting input of the error amplifier is referenced to INV. The output of the error amplifier is referenced to COMP. The non-inverting input is internally connected to a fixed 2.5V \pm 2% voltage. The output of the error amplifier is used to determine the on-time of the PWM output and regulate the output voltage. To achieve a low input current THD, the variation of the on-time within one input AC cycle should be very small. A multi-vector error amplifier is built in to provide fast transient response and precise output voltage clamping.

Connecting a capacitance, such as 1 μ F, between COMP and GND is suggested. The error amplifier is a trans-conductance amplifier that converts voltage to current with a 125 μ mho.

Startup Current

Typical startup current is less than 20 μ A. This ultra-low startup current allows the usage of a high resistance, low-wattage startup resistor. For example, 1M Ω /0.25W startup resistor and a 10 μ F/25V (V_{CC} hold-up) capacitor are recommended for an AC-to-DC power adaptor with a wide input range 85-265 V_{AC} .

Operating Current

Operating current is typically 4.5mA. The low operating current enables better efficiency and reduces the requirement of V_{CC} hold-up capacitance.

Maximum On-Time Operation

Given a fixed inductor value and maximum output power, the relationship between on-time and line voltage is:

$$t_{on} = \frac{2 \cdot L \cdot P_o}{V_{rms}^2 \cdot \eta} \quad (1)$$

If the line voltage is too low or the inductor value is too high, t_{ON} is too long. To avoid extra low operating frequency and achieve brownout protection, the maximum value of t_{ON} is programmable by one resistor, R_I , connected between MOT and GND. A 24k Ω resistor R_I generates corresponds to 25 μ s maximum on time:

$$t_{on(max)} = R_I(k\Omega) \cdot \frac{25}{24}(\mu s) \quad (2)$$

The range of the maximum on-time is 10 ~ 50 μ s.

Peak Current Limiting

The switch current is sensed by one resistor. The signal is fed into the CS pin and an input terminal of a comparator. A high voltage on the CS pin terminates the switching cycle immediately and cycle-by-cycle current limit is achieved. The designed threshold of the protection point is 0.82V.

Leading-Edge Blanking (LEB)

A turn-on spike on the CS pin appears when the power MOSFET is switched on. At the beginning of each switching pulse, the current-limit comparator is disabled for around 400ns to avoid premature termination. The gate drive output cannot be switched off during the blanking period. Conventional RC filtering is not necessary, so the propagation delay of current limit protection can be minimized.

Under-Voltage Lockout (UVLO)

The turn-on and turn-off threshold voltages are fixed internally at 12V and 9.5V, respectively. This hysteresis behavior guarantees a one-shot startup with proper startup resistor and hold-up capacitor. With an ultra-low startup current of 20 μ A, one 1M Ω R_{IN} is sufficient for startup under low input line voltage, 85 V_{rms} . Power dissipation on R_{IN} would be less than 0.1W even under high line (V_{AC} =265 V_{rms}) condition.

Output Driver

With low on resistance and high current driving capability, the output driver can drive an external capacitive load larger than 3000pF. Cross conduction current has been avoided to minimize heat dissipation, improving efficiency and reliability. This output driver is internally clamped by a 16.5V Zener diode.

Zero-Current Detection (ZCD)

The zero-current detection of the inductor is achieved using its auxiliary winding. When the stored energy of the inductor is fully released to output, the voltage on ZCD goes down and a new switching cycle is enabled after a ZCD trigger. The power MOSFET is always turned on with zero inductor current such that turn-on loss and noise can be minimized. The converter works in Boundary Mode and peak inductor current is always exactly twice of the average current. A natural power factor correction function is achieved with the low-bandwidth, on-time modulation. An inherent maximum off time is built in to ensure proper startup operation. This ZCD pin can be used as a synchronous input.

Noise Immunity

Noise on the current sense or control signal can cause significant pulse-width jitter, particularly in Boundary Mode. Slope compensation and a built-in debounce circuit can alleviate this problem. Because the FL6961 has a single ground pin, high sink current at the output cannot be returned separately. Good high-frequency or RF layout practices should be followed. Avoiding long PCB traces and component leads, locating compensation and filter components near to the FL6961, and increasing the power MOSFET gate resistance all improve performance.

Physical Dimensions

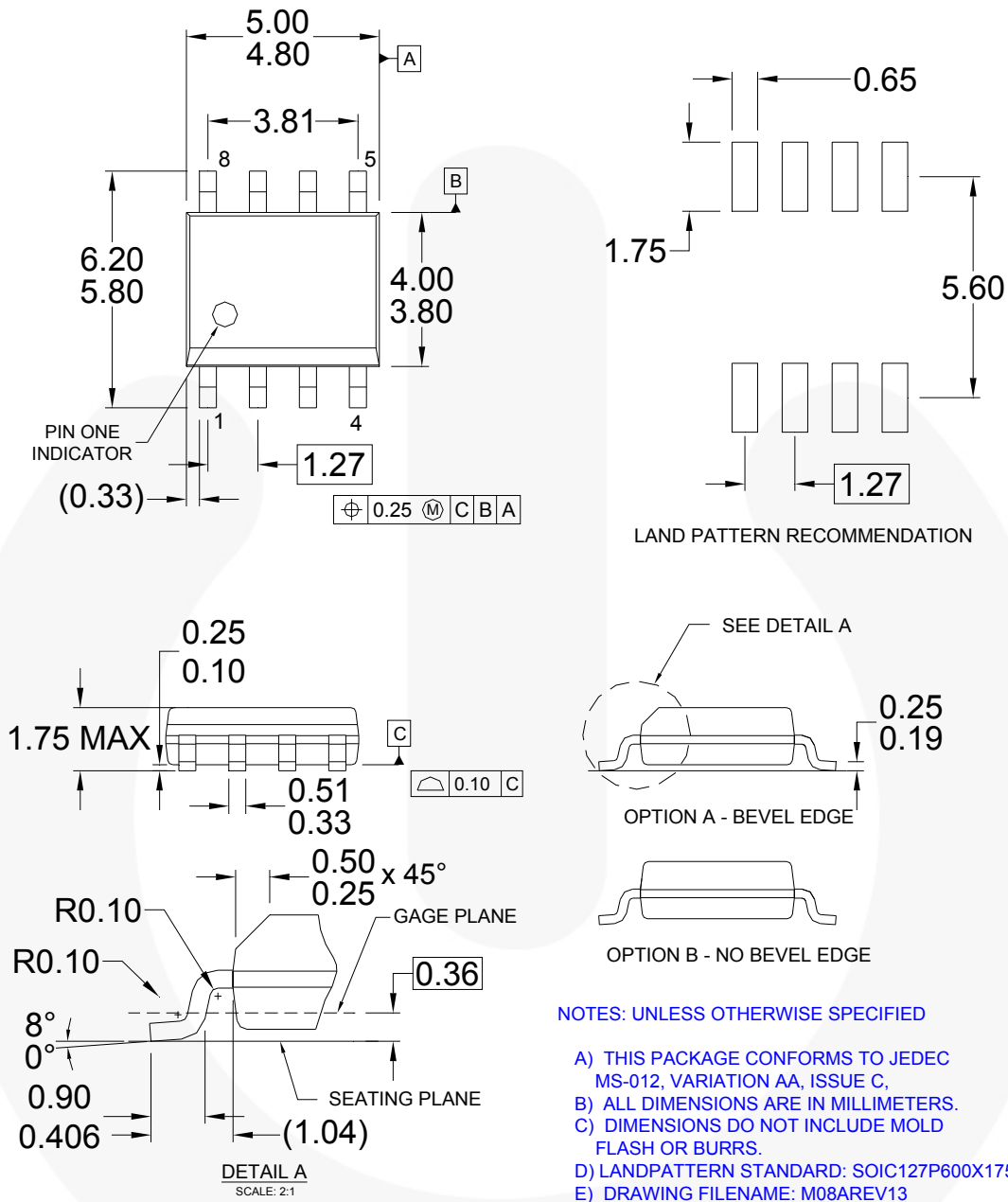

Figure 15. 8-Lead, SOIC, JEDEC MS-012, .150 Inch Narrow Body

Package drawings are provided as a service to customers considering Fairchild components. Drawings may change in any manner without notice. Please note the revision and/or date on the drawing and contact a Fairchild Semiconductor representative to verify or obtain the most recent revision. Package specifications do not expand the terms of Fairchild's worldwide terms and conditions, specifically the warranty therein, which covers Fairchild products.

Always visit Fairchild Semiconductor's online packaging area for the most recent package drawings:
<http://www.fairchildsemi.com/packaging/>.



TRADEMARKS

The following includes registered and unregistered trademarks and service marks, owned by Fairchild Semiconductor and/or its global subsidiaries, and is not intended to be an exhaustive list of all such trademarks.

2Cool™
AccuPower™
AX-CAP™*
BitSiC™
Build it Now™
CorePLUS™
CorePOWER™
CROSSVOLT™
CTL™
Current Transfer Logic™
DEUXPEED®
Dual Cool™
EcoSPARK®
EfficientMax™
ESBC™
F®
Fairchild®
Fairchild Semiconductor®
FACT Quiet Series™
FACT®
FAST®
FastvCore™
FETBench™
FlashWriter®*
FPS™

F-PFS™
FRFET®
Global Power Resource™
GreenBridge™
Green FPS™
Green FPS™ e-Series™
Gmax™
GTO™
IntelliMAX™
ISOPLANAR™
Making Small Speakers Sound Louder and Better™
MegaBuck™
MICROCOUPLER™
MicroFET™
MicroPak™
MicroPak2™
MillerDrive™
MotionMax™
Motion-SPM™
mWSaver™
OptoHit™
OPTOLOGIC®
OPTOPLANAR®

PowerTrench®
PowerXS™
Programmable Active Droop™
QFET®
QS™
Quiet Series™
RapidConfigure™
™
Saving our world, 1mW/kW at a time™
SignalWise™
SmartMax™
SMART START™
Solutions for Your Success™
SPM®
STEALTH™
SuperFET®
SuperSOT™-3
SuperSOT™-6
SuperSOT™-8
SupreMOS®
SyncFET™
Sync-Lock™
 SYSTEM GENERAL®*

The Power Franchise®
the **power** franchise
TinyBoost™
TinyBuck™
TinyCalc™
TinyLogic®
TINYOPTO™
TinyPower™
TinyPWM™
TinyWire™
TranSiC™
TriFault Detect™
TRUECURRENT®*
 uSerDes™
 SerDes™
UHC®
Ultra FRFET™
UniFET™
VCX™
VisualMax™
VoltagePlus™
XS™

* Trademarks of System General Corporation, used under license by Fairchild Semiconductor.

DISCLAIMER

FAIRCHILD SEMICONDUCTOR RESERVES THE RIGHT TO MAKE CHANGES WITHOUT FURTHER NOTICE TO ANY PRODUCTS HEREIN TO IMPROVE RELIABILITY, FUNCTION, OR DESIGN. FAIRCHILD DOES NOT ASSUME ANY LIABILITY ARISING OUT OF THE APPLICATION OR USE OF ANY PRODUCT OR CIRCUIT DESCRIBED HEREIN; NEITHER DOES IT CONVEY ANY LICENSE UNDER ITS PATENT RIGHTS, NOR THE RIGHTS OF OTHERS. THESE SPECIFICATIONS DO NOT EXPAND THE TERMS OF FAIRCHILD'S WORLDWIDE TERMS AND CONDITIONS, SPECIFICALLY THE WARRANTY THEREIN, WHICH COVERS THESE PRODUCTS.

LIFE SUPPORT POLICY

FAIRCHILD'S PRODUCTS ARE NOT AUTHORIZED FOR USE AS CRITICAL COMPONENTS IN LIFE SUPPORT DEVICES OR SYSTEMS WITHOUT THE EXPRESS WRITTEN APPROVAL OF FAIRCHILD SEMICONDUCTOR CORPORATION.

As used herein:

1. Life support devices or systems are devices or systems which, (a) are intended for surgical implant into the body or (b) support or sustain life, and (c) whose failure to perform when properly used in accordance with instructions for use provided in the labeling, can be reasonably expected to result in a significant injury of the user.
2. A critical component in any component of a life support, device, or system whose failure to perform can be reasonably expected to cause the failure of the life support device or system, or to affect its safety or effectiveness.

ANTI-COUNTERFEITING POLICY

Fairchild Semiconductor Corporation's Anti-Counterfeiting Policy. Fairchild's Anti-Counterfeiting Policy is also stated on our external website, www.fairchildsemi.com, under Sales Support.

Counterfeiting of semiconductor parts is a growing problem in the industry. All manufacturers of semiconductor products are experiencing counterfeiting of their parts. Customers who inadvertently purchase counterfeit parts experience many problems such as loss of brand reputation, substandard performance, failed applications, and increased cost of production and manufacturing delays. Fairchild is taking strong measures to protect ourselves and our customers from the proliferation of counterfeit parts. Fairchild strongly encourages customers to purchase Fairchild parts either directly from Fairchild or from Authorized Fairchild Distributors who are listed by country on our web page cited above. Products customers buy either from Fairchild directly or from Authorized Fairchild Distributors are genuine parts, have full traceability, meet Fairchild's quality standards for handling and storage and provide access to Fairchild's full range of up-to-date technical and product information. Fairchild and our Authorized Distributors will stand behind all warranties and will appropriately address any warranty issues that may arise. Fairchild will not provide any warranty coverage or other assistance for parts bought from Unauthorized Sources. Fairchild is committed to combat this global problem and encourage our customers to do their part in stopping this practice by buying direct or from authorized distributors.

PRODUCT STATUS DEFINITIONS

Definition of Terms

Datasheet Identification	Product Status	Definition
Advance Information	Formative / In Design	Datasheet contains the design specifications for product development. Specifications may change in any manner without notice.
Preliminary	First Production	Datasheet contains preliminary data; supplementary data will be published at a later date. Fairchild Semiconductor reserves the right to make changes at any time without notice to improve design.
No Identification Needed	Full Production	Datasheet contains final specifications. Fairchild Semiconductor reserves the right to make changes at any time without notice to improve the design.
Obsolete	Not In Production	Datasheet contains specifications on a product that is discontinued by Fairchild Semiconductor. The datasheet is for reference information only.

Rev. I61