



Is Now Part of



**ON Semiconductor®**

To learn more about ON Semiconductor, please visit our website at  
[www.onsemi.com](http://www.onsemi.com)

ON Semiconductor and the ON Semiconductor logo are trademarks of Semiconductor Components Industries, LLC dba ON Semiconductor or its subsidiaries in the United States and/or other countries. ON Semiconductor owns the rights to a number of patents, trademarks, copyrights, trade secrets, and other intellectual property. A listing of ON Semiconductor's product/patent coverage may be accessed at [www.onsemi.com/site/pdf/Patent-Marking.pdf](http://www.onsemi.com/site/pdf/Patent-Marking.pdf). ON Semiconductor reserves the right to make changes without further notice to any products herein. ON Semiconductor makes no warranty, representation or guarantee regarding the suitability of its products for any particular purpose, nor does ON Semiconductor assume any liability arising out of the application or use of any product or circuit, and specifically disclaims any and all liability, including without limitation special, consequential or incidental damages. Buyer is responsible for its products and applications using ON Semiconductor products, including compliance with all laws, regulations and safety requirements or standards, regardless of any support or applications information provided by ON Semiconductor. "Typical" parameters which may be provided in ON Semiconductor data sheets and/or specifications can and do vary in different applications and actual performance may vary over time. All operating parameters, including "Typicals" must be validated for each customer application by customer's technical experts. ON Semiconductor does not convey any license under its patent rights nor the rights of others. ON Semiconductor products are not designed, intended, or authorized for use as a critical component in life support systems or any FDA Class 3 medical devices or medical devices with a same or similar classification in a foreign jurisdiction or any devices intended for implantation in the human body. Should Buyer purchase or use ON Semiconductor products for any such unintended or unauthorized application, Buyer shall indemnify and hold ON Semiconductor and its officers, employees, subsidiaries, affiliates, and distributors harmless against all claims, costs, damages, and expenses, and reasonable attorney fees arising out of, directly or indirectly, any claim of personal injury or death associated with such unintended or unauthorized use, even if such claim alleges that ON Semiconductor was negligent regarding the design or manufacture of the part. ON Semiconductor is an Equal Opportunity/Affirmative Action Employer. This literature is subject to all applicable copyright laws and is not for resale in any manner.

# LM555 Single Timer

## Features

- High-Current Drive Capability: 200 mA
- Adjustable Duty Cycle
- Temperature Stability of 0.005%/°C
- Timing From  $\mu\text{s}$  to Hours
- Turn off Time Less Than 2  $\mu\text{s}$

## Applications

- Precision Timing
- Pulse Generation
- Delay Generation
- Sequential Timing

## Description

The LM555 is a highly stable controller capable of producing accurate timing pulses. With a monostable operation, the delay is controlled by one external resistor and one capacitor. With astable operation, the frequency and duty cycle are accurately controlled by two external resistors and one capacitor.

8-DIP



8-SOIC



## Ordering Information

Part Number	Operating Temperature Range	Top Mark	Package	Packing Method
LM555CN	0 ~ +70°C	LM555CN	DIP 8L	Rail
LM555CM		LM555CM	SOIC 8L	Rail
LM555CMX		LM555CM	SOIC 8L	Tape & Reel

## Block Diagram

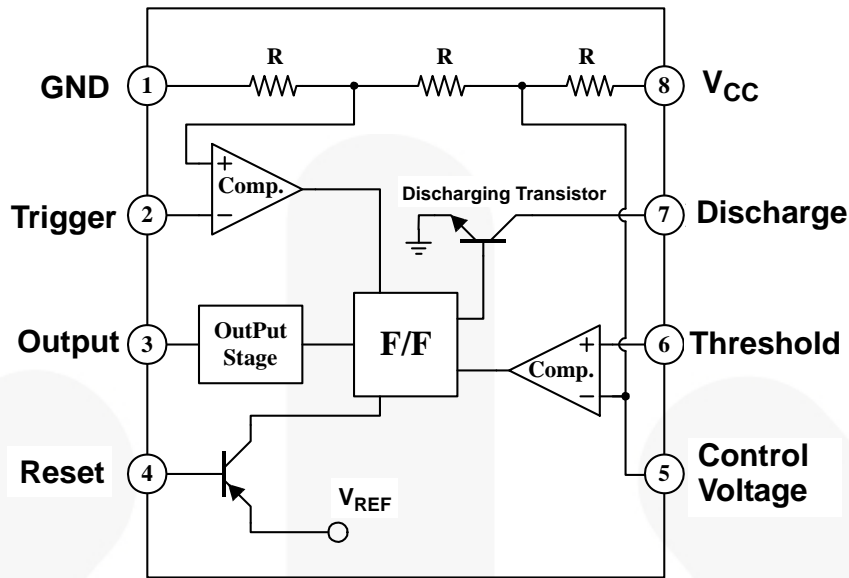


Figure 1. Block Diagram

## Absolute Maximum Ratings

Stresses exceeding the absolute maximum ratings may damage the device. The device may not function or be operable above the recommended operating conditions and stressing the parts to these levels is not recommended. In addition, extended exposure to stresses above the recommended operating conditions may affect device reliability. The absolute maximum ratings are stress ratings only. Values are at  $T_A = 25^\circ\text{C}$  unless otherwise noted.

Symbol	Parameter	Value	Unit
$V_{CC}$	Supply Voltage	16	V
$T_{LEAD}$	Lead Temperature (Soldering 10s)	300	$^\circ\text{C}$
$P_D$	Power Dissipation	600	mW
$T_{OPR}$	Operating Temperature Range	0 ~ +70	$^\circ\text{C}$
$T_{STG}$	Storage Temperature Range	-65 ~ +150	$^\circ\text{C}$

## Electrical Characteristics

Values are at  $T_A = 25^\circ\text{C}$ ,  $V_{CC} = 5 \sim 15\text{ V}$  unless otherwise specified.

Parameter	Symbol	Conditions	Min.	Typ.	Max.	Unit
Supply Voltage	$V_{CC}$		4.5		16.0	V
Supply Current (Low Stable) <sup>(1)</sup>	$I_{CC}$	$V_{CC} = 5\text{ V}, R_L = \infty$		3	6	mA
		$V_{CC} = 15\text{ V}, R_L = \infty$		7.5	15.0	mA
Timing Error (Monostable) Initial Accuracy <sup>(2)</sup>	ACCUR	$R_A = 1\text{ k}\Omega$ to $100\text{ k}\Omega$ $C = 0.1\text{ }\mu\text{F}$		1.0	3.0	%
Drift with Temperature <sup>(3)</sup>	$\Delta t / \Delta T$			50		ppm / $^\circ\text{C}$
Drift with Supply Voltage <sup>(3)</sup>	$\Delta t / \Delta V_{CC}$			0.1	0.5	% / V
Timing Error (Astable) Initial Accuracy <sup>(2)</sup>	ACCUR	$R_A = 1\text{ k}\Omega$ to $100\text{ k}\Omega$ $C = 0.1\text{ }\mu\text{F}$		2.25		%
Drift with Temperature <sup>(3)</sup>	$\Delta t / \Delta T$			150		ppm / $^\circ\text{C}$
Drift with Supply Voltage <sup>(3)</sup>	$\Delta t / \Delta V_{CC}$			0.3		% / V
Control Voltage	$V_C$	$V_{CC} = 15\text{ V}$	9.0	10.0	11.0	V
		$V_{CC} = 5\text{ V}$	2.60	3.33	4.00	V
Threshold Voltage	$V_{TH}$	$V_{CC} = 15\text{ V}$		10.0		V
		$V_{CC} = 5\text{ V}$		3.33		V
Threshold Current <sup>(4)</sup>	$I_{TH}$			0.10	0.25	$\mu\text{A}$
Trigger Voltage	$V_{TR}$	$V_{CC} = 5\text{ V}$	1.10	1.67	2.20	V
		$V_{CC} = 15\text{ V}$	4.5	5.0	5.6	V
Trigger Current	$I_{TR}$	$V_{TR} = 0\text{ V}$		0.01	2.00	$\mu\text{A}$
Reset Voltage	$V_{RST}$		0.4	0.7	1.0	V
Reset Current	$I_{RST}$			0.1	0.4	mA
Low Output Voltage	$V_{OL}$	$V_{CC} = 15\text{ V}$ , $I_{SINK} = 10\text{ mA}$		0.06	0.25	V
		$V_{CC} = 15\text{ V}$ , $I_{SINK} = 50\text{ mA}$		0.30	0.75	V
		$V_{CC} = 5\text{ V}$ , $I_{SINK} = 5\text{ mA}$		0.05	0.35	V
High Output Voltage	$V_{OH}$	$V_{CC} = 15\text{ V}$ , $I_{SOURCE} = 200\text{ mA}$		12.5		V
		$V_{CC} = 15\text{ V}$ , $I_{SOURCE} = 100\text{ mA}$	12.75	13.30		V
		$V_{CC} = 5\text{ V}$ , $I_{SOURCE} = 100\text{ mA}$	2.75	3.30		V
Rise Time of Output <sup>(3)</sup>	$t_R$			100		ns
Fall Time of Output <sup>(3)</sup>	$t_F$			100		ns
Discharge Leakage Current	$I_{LKG}$			20	100	nA

### Notes:

- When the output is high, the supply current is typically 1 mA less than at  $V_{CC} = 5\text{ V}$ .
- Tested at  $V_{CC} = 5.0\text{ V}$  and  $V_{CC} = 15\text{ V}$ .
- These parameters, although guaranteed, are not 100% tested in production.
- This determines the maximum value of  $R_A + R_B$  for 15 V operation, the maximum total  $R = 20\text{ M}\Omega$ , and for 5 V operation, the maximum total  $R = 6.7\text{ M}\Omega$ .

## Application Information

Table 1 below is the basic operating table of 555 timer.

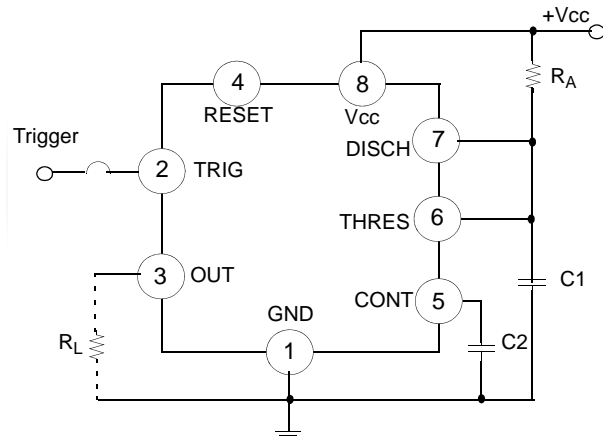
**Table 1. Basic Operating Table**

Reset (PIN 4)	$V_{TR}$ (PIN 2)	$V_{TH}$ (PIN 6)	Output (PIN 3)	Discharging Transistor (PIN 7)
Low	X	X	Low	ON
High	$< 1/3 V_{CC}$	X	High	OFF
High	$> 1/3 V_{CC}$	$> 2/3 V_{CC}$	Low	ON
High	$> 1/3 V_{CC}$	$< 2/3 V_{CC}$	Previous State	

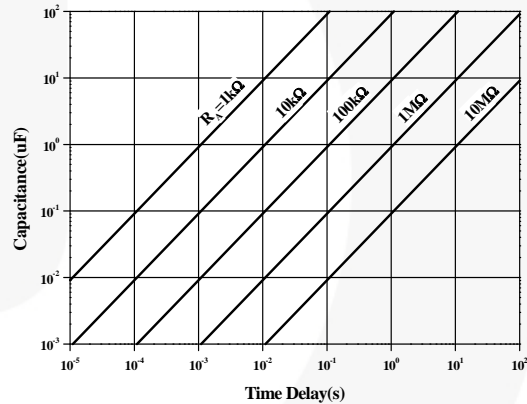
When the low signal input is applied to the reset terminal, the timer output remains low regardless of the threshold voltage or the trigger voltage. Only when the high signal is applied to the reset terminal, the timer's output changes according to threshold voltage and trigger voltage.

When the threshold voltage exceeds 2/3 of the supply voltage while the timer output is high, the timer's internal discharge transistor turns on, lowering the threshold voltage to below 1/3 of the supply voltage. During this time, the timer output is maintained low. Later, if a low signal is applied to the trigger voltage so that it becomes 1/3 of the supply voltage, the timer's internal discharge transistor turns off, increasing the threshold voltage and driving the timer output again at high.

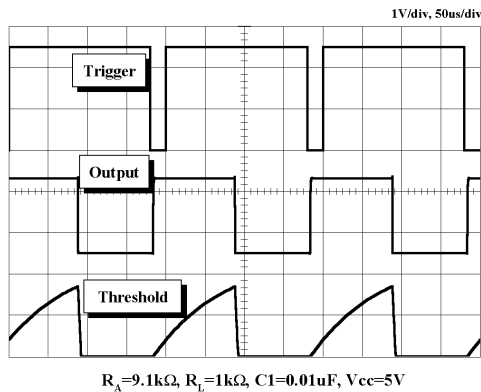
### 1. Monostable Operation



**Figure 2. Monostable Circuit**



**Figure 3. Resistance and Capacitance vs. Time Delay ( $t_D$ )**



**Figure 4. Waveforms of Monostable Operation**

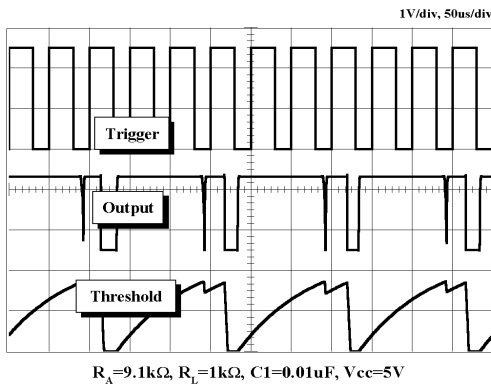
### 1. Monostable Operation

Figure 2 illustrates a monostable circuit. In this mode, the timer generates a fixed pulse whenever the trigger voltage falls below  $V_{CC}/3$ . When the trigger pulse voltage applied to the #2 pin falls below  $V_{CC}/3$  while the timer output is low, the timer's internal flip-flop turns the discharging transistor off and causes the timer output to become high by charging the external capacitor C1 and setting the flip-flop output at the same time.

The voltage across the external capacitor C1,  $V_{C1}$  increases exponentially with the time constant  $t = R_A * C$  and reaches  $2 V_{CC}/3$  at  $t_D = 1.1 R_A * C$ . Hence, capacitor C1 is charged through resistor  $R_A$ . The greater the time constant  $R_A C$ , the longer it takes for the  $V_{C1}$  to reach  $2 V_{CC}/3$ . In other words, the time constant  $R_A C$  controls the output pulse width.

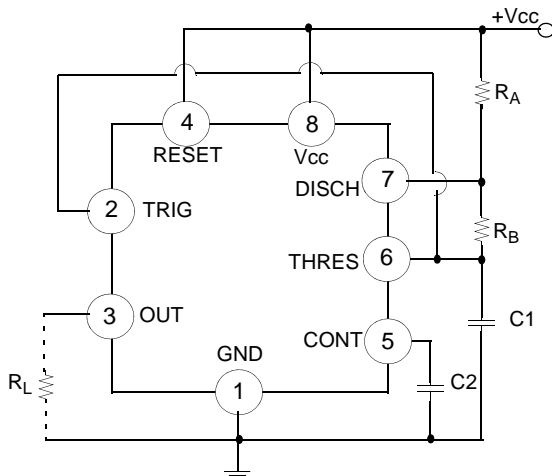
When the applied voltage to the capacitor C1 reaches  $2 V_{CC}/3$ , the comparator on the trigger terminal resets the flip-flop, turning the discharging transistor on. At this time, C1 begins to discharge and the timer output converts to low. In this way, the timer operating in the monostable repeats the above process. Figure 3 shows the time constant relationship based on  $R_A$  and C. Figure 4 shows the general waveforms during the monostable operation.

It must be noted that, for a normal operation, the trigger pulse voltage needs to maintain a minimum of  $V_{CC}/3$  before the timer output turns low. That is, although the output remains unaffected even if a different trigger pulse is applied while the output is high, it may be affected and the waveform does not operate properly if the trigger pulse voltage at the end of the output pulse remains at below  $V_{CC}/3$ . Figure 5 shows such a timer output abnormality.

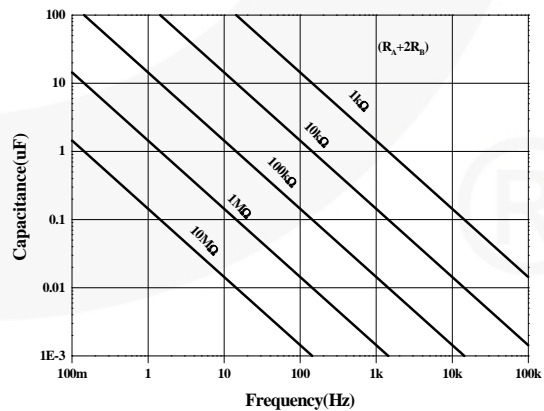


**Figure 5. Waveforms of Monostable Operation (abnormal)**

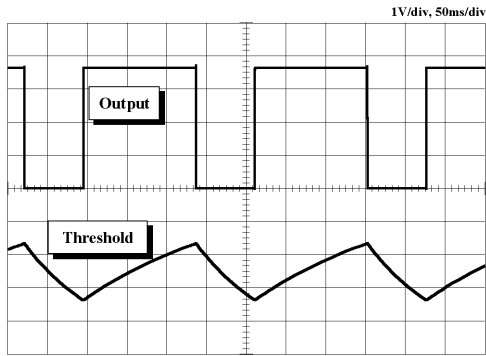
### 2. Astable Operation



**Figure 6. A Stable Circuit**



**Figure 7. Capacitance and Resistance vs. Frequency**



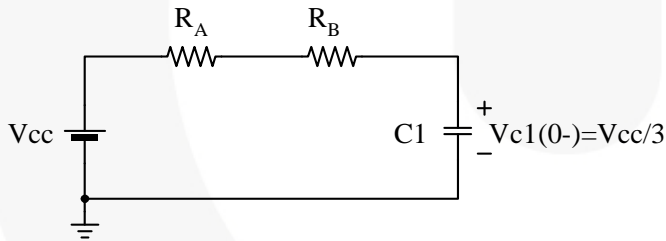
$R_A=1k\Omega, R_B=1k\Omega, R_L=1k\Omega, C1=1\mu F, V_{CC}=5V$

**Figure 8. Waveforms of Astable Operation**

An astable timer operation is achieved by adding resistor  $R_B$  to Figure 2 and configuring as shown on Figure 6. In the astable operation, the trigger terminal and the threshold terminal are connected so that a self-trigger is formed, operating as a multi-vibrator. When the timer output is high, its internal discharging transistor turns off and the  $V_{C1}$  increases by exponential function with the time constant  $(R_A+R_B)*C$ .

When the  $V_{C1}$ , or the threshold voltage, reaches  $2 V_{CC}/3$ ; the comparator output on the trigger terminal becomes high, resetting the F/F and causing the timer output to become low. This turns on the discharging transistor and the  $C1$  discharges through the discharging channel formed by  $R_B$  and the discharging transistor. When the  $V_{C1}$  falls below  $V_{CC}/3$ , the comparator output on the trigger terminal becomes high and the timer output becomes high again. The discharging transistor turns off and the  $V_{C1}$  rises again.

In the above process, the section where the timer output is high is the time it takes for the  $V_{C1}$  to rise from  $V_{CC}/3$  to  $2 V_{CC}/3$ , and the section where the timer output is low is the time it takes for the  $V_{C1}$  to drop from  $2 V_{CC}/3$  to  $V_{CC}/3$ . When timer output is high, the equivalent circuit for charging capacitor  $C1$  is as follows:



$$C_1 \frac{dv_{c1}}{dt} = \frac{V_{CC} - V(0-)}{R_A + R_B} \quad (1)$$

$$V_{C1}(0+) = V_{CC}/3 \quad (2)$$

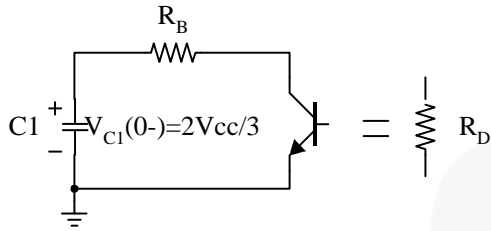
$$V_{C1}(t) = V_{CC} \left( 1 - \frac{2}{3} e^{-\left(\frac{t}{(R_A + R_B)C_1}\right)} \right) \quad (3)$$

Since the duration of the timer output high state ( $t_H$ ) is the amount of time it takes for the  $V_{C1}(t)$  to reach  $2 V_{CC}/3$ ,

$$V_{C1}(t) = \frac{2}{3}V_{CC} = V_{CC} \left( 1 - \frac{2}{3} e^{-\left(\frac{t_H}{(R_A + R_B)C_1}\right)} \right) \quad (4)$$

$$t_H = C_1(R_A + R_B) \ln 2 = 0.693(R_A + R_B)C_1 \quad (5)$$

The equivalent circuit for discharging capacitor C1, when timer output is low is, as follows:



$$C_1 \frac{dv_{C1}}{dt} + \frac{1}{R_A + R_B} v_{C1} = 0 \quad (6)$$

$$v_{C1}(t) = \frac{2}{3} V_{CC} e^{-\frac{t}{(R_A + R_D)C_1}} \quad (7)$$

Since the duration of the timer output low state ( $t_L$ ) is the amount of time it takes for the  $v_{C1}(t)$  to reach  $V_{CC}/3$ ,

$$\frac{1}{3} V_{CC} = \frac{2}{3} V_{CC} e^{-\frac{t_L}{(R_A + R_D)C_1}} \quad (8)$$

$$t_L = C_1(R_B + R_D) \ln 2 = 0.693(R_B + R_D)C_1 \quad (9)$$

Since  $R_D$  is normally  $R_B \gg R_D$  although related to the size of discharging transistor,

$$t_L = 0.693R_B C_1 \quad (10)$$

Consequently, if the timer operates in astable, the period is the same with ' $t = t_H + t_L = 0.693(R_A + R_B)C_1 + 0.693R_B C_1 = 0.693(R_A + 2R_B)C_1$ '

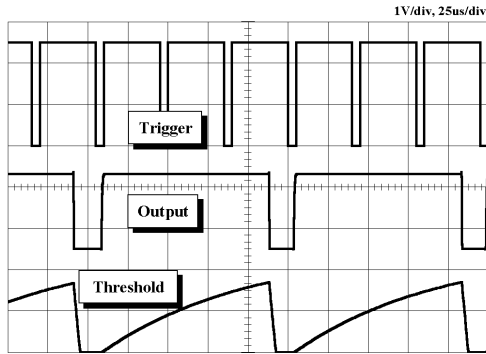
because the period is the sum of the charge time and discharge time. Since frequency is the reciprocal of the period, the following applies:

$$\text{frequency, } f = \frac{1}{t} = \frac{1.44}{(R_A + 2R_B)C_1} \quad (11)$$



### 3. Frequency Divider

By adjusting the length of the timing cycle, the basic circuit of Figure 1 can be made to operate as a frequency divider. Figure 9. illustrates a divide-by-three circuit that makes use of the fact that retriggering cannot occur during the timing cycle.



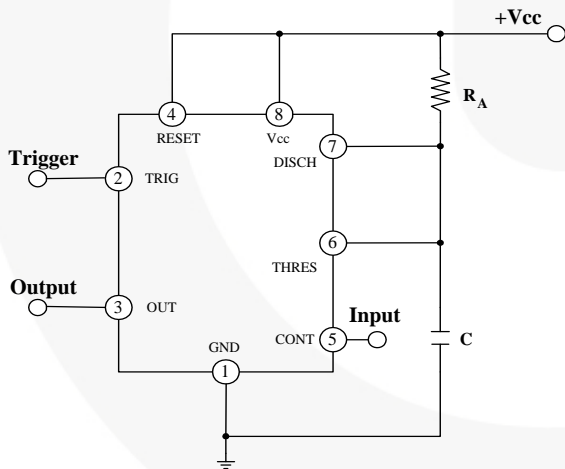
$R_A=9.1k\Omega$ ,  $R_L=1k\Omega$ ,  $C1=0.01\mu F$ ,  $V_{cc}=5V$

**Figure 9. Waveforms of Frequency Divider Operation**

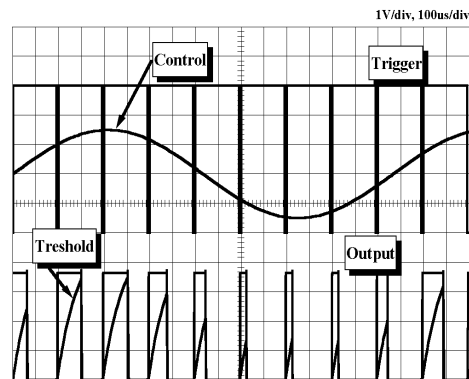
### 4. Pulse Width Modulation

The timer output waveform may be changed by modulating the control voltage applied to the timer's pin 5 and changing the reference of the timer's internal comparators. Figure 10 illustrates the pulse width modulation circuit.

When the continuous trigger pulse train is applied in the monostable mode, the timer output width is modulated according to the signal applied to the control terminal. Sine wave, as well as other waveforms, may be applied as a signal to the control terminal. Figure 11 shows the example of pulse width modulation waveform.



**Figure 10. Circuit for Pulse Width Modulation**



$R_A=9.1k\Omega$ ,  $R_L=1k\Omega$ ,  $C1=0.01\mu F$ ,  $V_{cc}=5V$

**Figure 11. Waveforms of Pulse Width Modulation**

### 5. Pulse Position Modulation

If the modulating signal is applied to the control terminal while the timer is connected for the astable operation, as in Figure 12, the timer becomes a pulse position modulator. In the pulse position modulator, the reference of the timer's internal comparators is modulated, which modulates the timer output according to the modulation signal applied to the control terminal. Figure 13 illustrates a sine wave for modulation signal and the resulting output pulse position modulation; however, any wave shape can be used.

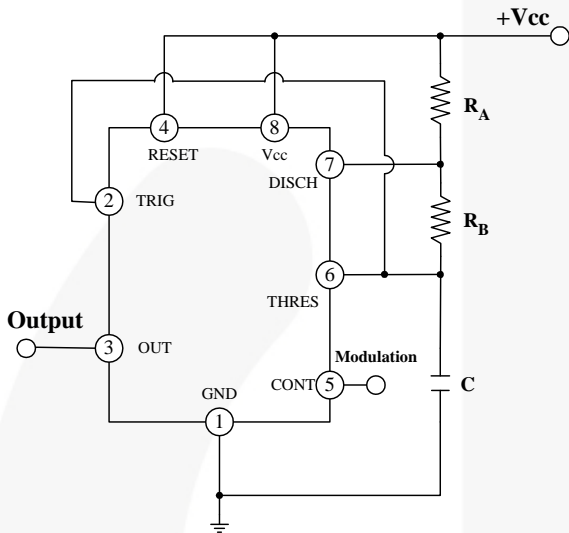


Figure 12. Circuit for Pulse Position Modulation

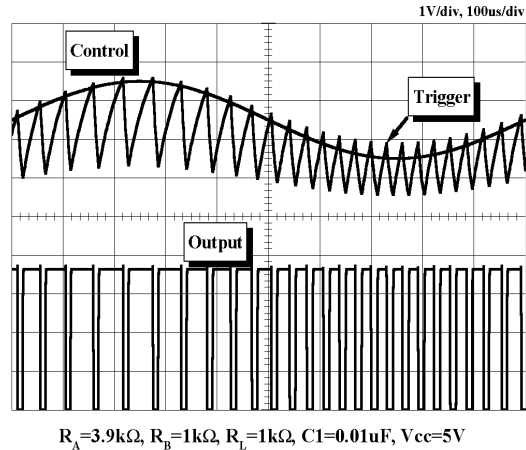


Figure 13. Waveforms of pulse position modulation

### 6. Linear Ramp

When the pull-up resistor  $R_A$  in the monostable circuit shown in Figure 2 is replaced with constant current source, the  $V_{C1}$  increases linearly, generating a linear ramp. Figure 14 shows the linear ramp generating circuit and Figure 15 illustrates the generated linear ramp waveforms.

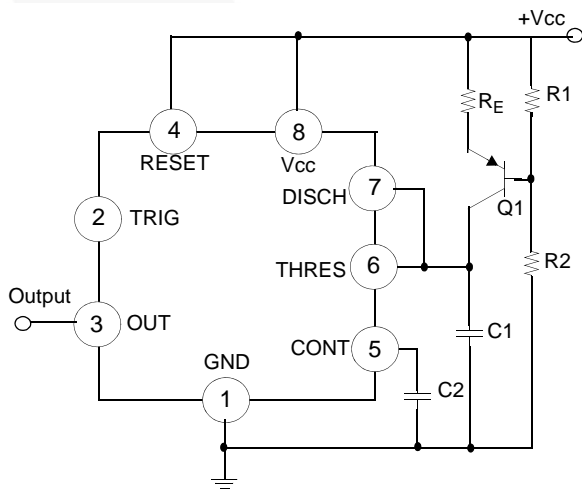


Figure 14. Circuit for Linear Ramp

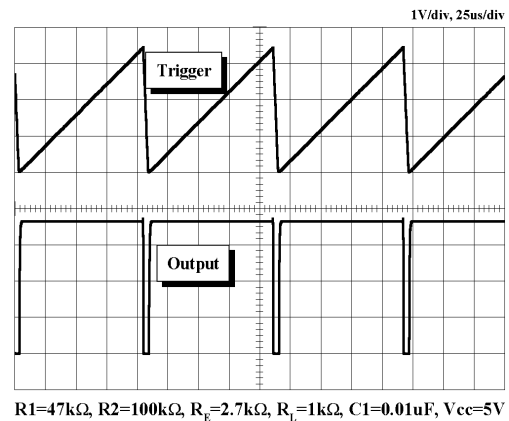


Figure 15. Waveforms of Linear Ramp

In Figure 14, current source is created by PNP transistor Q1 and resistor R1, R2, and R<sub>E</sub>.

$$I_C = \frac{V_{CC} - V_E}{R_E} \quad (12)$$

Here, V<sub>E</sub> is

$$V_E = V_{BE} + \frac{R_2}{R_1 + R_2} V_{CC} \quad (13)$$

For example, if V<sub>CC</sub> = 15 V, R<sub>E</sub> = 20 kΩ, R<sub>1</sub> = 5 kΩ, R<sub>2</sub> = 10 kΩ, and V<sub>BE</sub> = 0.7 V, V<sub>E</sub> = 0.7 V + 10 V = 10.7 V, and I<sub>C</sub> = (15 - 10.7) / 20 k = 0.215 mA.

When the trigger starts in a timer configured as shown in Figure 14, the current flowing through capacitor C1 becomes a constant current generated by PNP transistor and resistors.

Hence, the V<sub>C</sub> is a linear ramp function as shown in Figure 15. The gradient S of the linear ramp function is defined as follows:

$$S = \frac{V_{p-p}}{t} \quad (14)$$

Here the V<sub>p-p</sub> is the peak-to-peak voltage.

If the electric charge amount accumulated in the capacitor is divided by the capacitance, the V<sub>C</sub> comes out as follows:

$$V = Q/C \quad (15)$$

The above equation divided on both sides by t gives:

$$\frac{V}{t} = \frac{Q \text{ } \S \text{ } t}{C} \quad (16)$$

and may be simplified into the following equation:

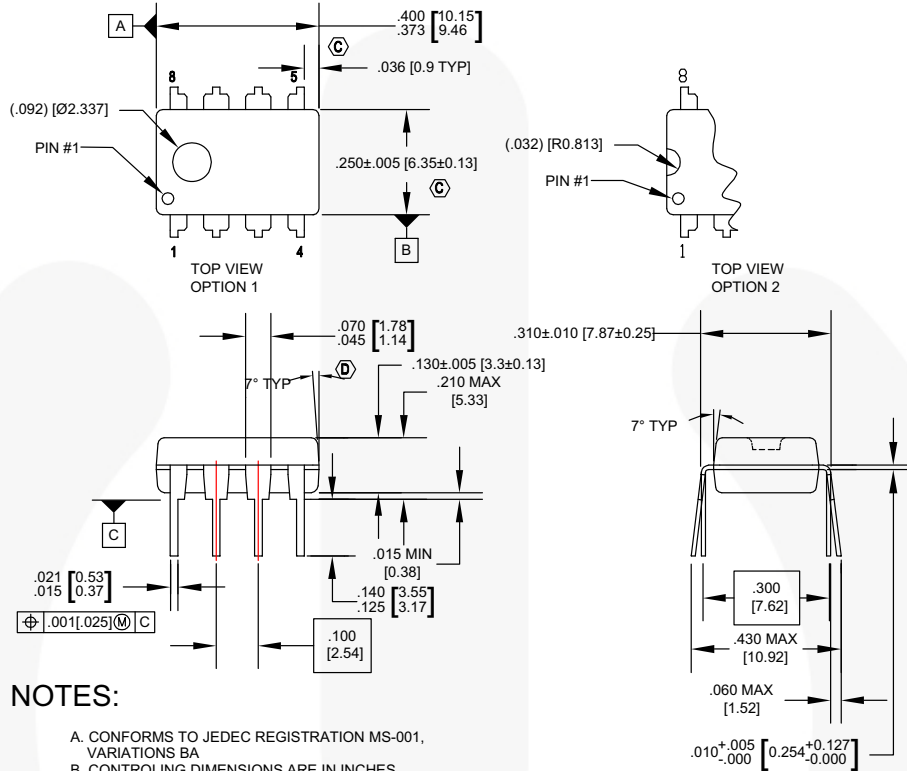
$$S = I/C \quad (17)$$

In other words, the gradient of the linear ramp function appearing across the capacitor can be obtained by using the constant current flowing through the capacitor.

If the constant current flow through the capacitor is 0.215 mA and the capacitance is 0.02 μF, the gradient of the ramp function at both ends of the capacitor is S = 0.215 m / 0.022 μ = 9.77 V/ms.

Physical Dimensions

8-DIP



NOTES:

- A. CONFORMS TO JEDEC REGISTRATION MS-001, VARIATIONS BA
- B. CONTROLLING DIMENSIONS ARE IN INCHES  
REFERENCE DIMENSIONS ARE IN MILLIMETERS
- C. DOES NOT INCLUDE MOLD FLASH OR PROTRUSIONS.  
MOLD FLASH OR PROTRUSIONS SHALL NOT EXCEED  
.010 INCHES OR 0.25MM.
- D. DOES NOT INCLUDE DAMBAR PROTRUSIONS.  
DAMBAR PROTRUSIONS SHALL NOT EXCEED  
.010 INCHES OR 0.25MM.
- E. DIMENSIONING AND TOLERANCING  
PER ASME Y14.5M-1994.

N08EREVG

Figure 16. 8-Lead, DIP, JEDEC MS-001, 300" WIDE

Package drawings are provided as a service to customers considering Fairchild components. Drawings may change in any manner without notice. Please note the revision and/or date on the drawing and contact a Fairchild Semiconductor representative to verify or obtain the most recent revision. Package specifications do not expand the terms of Fairchild's worldwide terms and conditions, specifically the warranty therein, which covers Fairchild products.

Always visit Fairchild Semiconductor's online packaging area for the most recent package drawings:  
<http://www.fairchildsemi.com/packaging/>.

For current tape and reel specifications, visit Fairchild Semiconductor's online packaging area:  
[http://www.fairchildsemi.com/products/discrete/pdf/8dip\\_tr.pdf](http://www.fairchildsemi.com/products/discrete/pdf/8dip_tr.pdf).

Physical Dimensions (continued)

8-SOIC

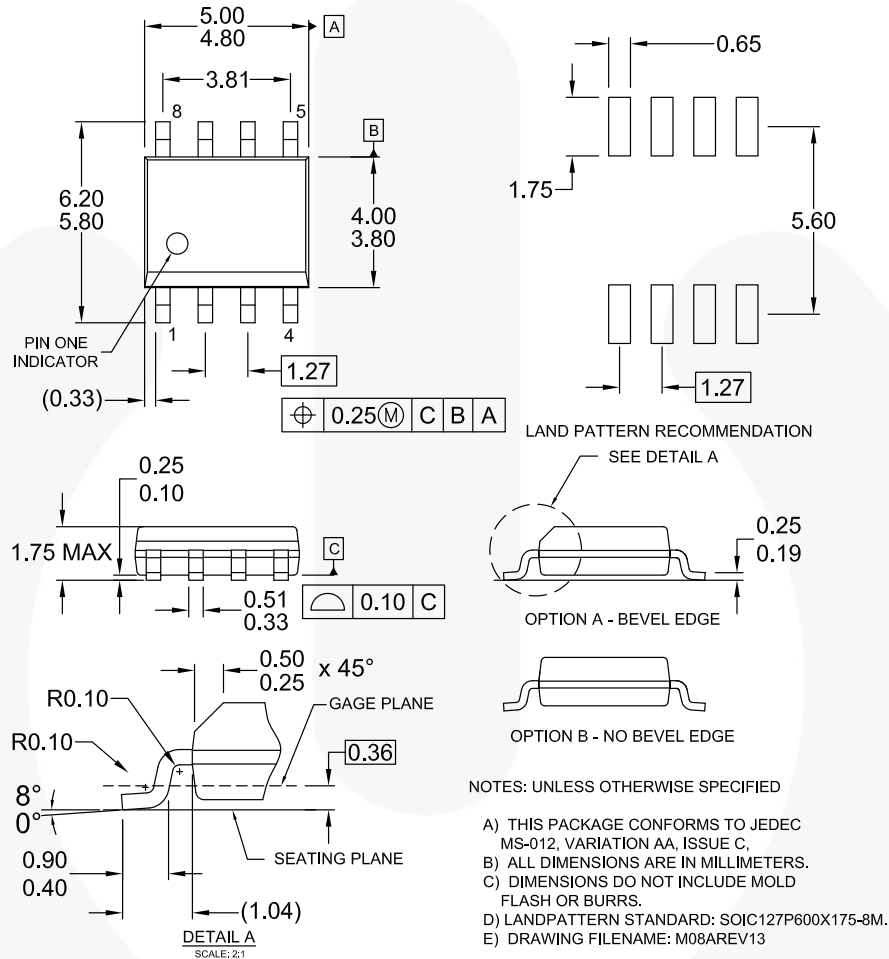


Figure 17. 8-Lead, SOIC, JEDEC MS-012, 150" NARROW BODY

Package drawings are provided as a service to customers considering Fairchild components. Drawings may change in any manner without notice. Please note the revision and/or date on the drawing and contact a Fairchild Semiconductor representative to verify or obtain the most recent revision. Package specifications do not expand the terms of Fairchild's worldwide terms and conditions, specifically the warranty therein, which covers Fairchild products.

Always visit Fairchild Semiconductor's online packaging area for the most recent package drawings:  
<http://www.fairchildsemi.com/packaging/>

For current tape and reel specifications, visit Fairchild Semiconductor's online packaging area:  
<http://www.fairchildsemi.com/dwg/M0/M08A.pdf>



**TRADEMARKS**

The following includes registered and unregistered trademarks and service marks, owned by Fairchild Semiconductor and/or its global subsidiaries, and is not intended to be an exhaustive list of all such trademarks.

2Cool™  
AccuPower™  
AX-CAP™\*  
BitSiC™  
Build it Now™  
CorePLUS™  
CorePOWER™  
CROSSVOLT™  
CTL™  
Current Transfer Logic™  
DEUXPEED®  
Dual Cool™  
EcoSPARK®  
EfficientMax™  
ESBC™  
**F**®  
Fairchild®  
Fairchild Semiconductor®  
FACT Quiet Series™  
FACT®  
FAST®  
FastvCore™  
FETBench™  
FPS™

F-PFS™  
FRFET®  
Global Power Resource<sup>SM</sup>  
GreenBridge™  
Green FPS™  
Green FPS™ e-Series™  
Gmax™  
GTO™  
IntelliMAX™  
ISOPLANAR™  
Making Small Speakers Sound Louder and Better™  
MegaBuck™  
MICROCOUPLER™  
MicroFET™  
MicroPak™  
MicroPak2™  
MillerDrive™  
MotionMax™  
mW saver™  
OptoHiT™  
OPTOLOGIC®  
OPTOPLANAR®

PowerTrench®  
PowerXS™  
Programmable Active Droop™  
QFET®  
QS™  
Quiet Series™  
RapidConfigure™  
™  
Saving our world, 1mW/W/kW at a time™  
SignalWise™  
SmartMax™  
SMART START™  
Solutions for Your Success™  
SPM®  
STEALTH™  
SuperFET®  
SuperSOT™-3  
SuperSOT™-6  
SuperSOT™-8  
SupreMOS®  
SyncFET™  
Sync-Lock™  
 SYSTEM GENERAL®\*

The Power Franchise®  
the **power** franchise  
TinyBoost™  
TinyBuck™  
TinyCalc™  
TinyLogic®  
TINYOPTO™  
TinyPower™  
TinyPWM™  
TinyWire™  
TranSiC™  
TriFault Detect™  
TRUECURRENT®\*  
µSerDes™  
 SerDes®  
UHC®  
Ultra FRFET™  
UniFET™  
VCX™  
VisualMax™  
VoltagePlus™  
XS™

\* Trademarks of System General Corporation, used under license by Fairchild Semiconductor.

**DISCLAIMER**

FAIRCHILD SEMICONDUCTOR RESERVES THE RIGHT TO MAKE CHANGES WITHOUT FURTHER NOTICE TO ANY PRODUCTS HEREIN TO IMPROVE RELIABILITY, FUNCTION, OR DESIGN. FAIRCHILD DOES NOT ASSUME ANY LIABILITY ARISING OUT OF THE APPLICATION OR USE OF ANY PRODUCT OR CIRCUIT DESCRIBED HEREIN; NEITHER DOES IT CONVEY ANY LICENSE UNDER ITS PATENT RIGHTS, NOR THE RIGHTS OF OTHERS. THESE SPECIFICATIONS DO NOT EXPAND THE TERMS OF FAIRCHILD'S WORLDWIDE TERMS AND CONDITIONS, SPECIFICALLY THE WARRANTY THEREIN, WHICH COVERS THESE PRODUCTS.

**LIFE SUPPORT POLICY**

FAIRCHILD'S PRODUCTS ARE NOT AUTHORIZED FOR USE AS CRITICAL COMPONENTS IN LIFE SUPPORT DEVICES OR SYSTEMS WITHOUT THE EXPRESS WRITTEN APPROVAL OF FAIRCHILD SEMICONDUCTOR CORPORATION.

As used herein:

1. Life support devices or systems are devices or systems which, (a) are intended for surgical implant into the body or (b) support or sustain life, and (c) whose failure to perform when properly used in accordance with instructions for use provided in the labeling, can be reasonably expected to result in a significant injury of the user.
2. A critical component in any component of a life support, device, or system whose failure to perform can be reasonably expected to cause the failure of the life support device or system, or to affect its safety or effectiveness.

**ANTI-COUNTERFEITING POLICY**

Fairchild Semiconductor Corporation's Anti-Counterfeiting Policy. Fairchild's Anti-Counterfeiting Policy is also stated on our external website, [www.fairchildsemi.com](http://www.fairchildsemi.com), under Sales Support.

Counterfeiting of semiconductor parts is a growing problem in the industry. All manufacturers of semiconductor products are experiencing counterfeiting of their parts. Customers who inadvertently purchase counterfeit parts experience many problems such as loss of brand reputation, substandard performance, failed applications, and increased cost of production and manufacturing delays. Fairchild is taking strong measures to protect ourselves and our customers from the proliferation of counterfeit parts. Fairchild strongly encourages customers to purchase Fairchild parts either directly from Fairchild or from Authorized Fairchild Distributors who are listed by country on our web page cited above. Products customers buy either from Fairchild directly or from Authorized Fairchild Distributors are genuine parts, have full traceability, meet Fairchild's quality standards for handling and storage and provide access to Fairchild's full range of up-to-date technical and product information. Fairchild and our Authorized Distributors will stand behind all warranties and will appropriately address any warranty issues that may arise. Fairchild will not provide any warranty coverage or other assistance for parts bought from Unauthorized Sources. Fairchild is committed to combat this global problem and encourage our customers to do their part in stopping this practice by buying direct or from authorized distributors.

**PRODUCT STATUS DEFINITIONS**

**Definition of Terms**

Datasheet Identification	Product Status	Definition
Advance Information	Formative / In Design	Datasheet contains the design specifications for product development. Specifications may change in any manner without notice.
Preliminary	First Production	Datasheet contains preliminary data; supplementary data will be published at a later date. Fairchild Semiconductor reserves the right to make changes at any time without notice to improve design.
No Identification Needed	Full Production	Datasheet contains final specifications. Fairchild Semiconductor reserves the right to make changes at any time without notice to improve the design.
Obsolete	Not In Production	Datasheet contains specifications on a product that is discontinued by Fairchild Semiconductor. The datasheet is for reference information only.

Rev. I63