

PCNNumber: 1319

### Product/Process Change Notification (PCN)

**Customer:** Newark

**Date:** December 28, 2015

**Customer Part #'s affected:**

A1150LLHLT-T	A1156LLHLT-T	A1192LLHLX-T
A1150LLHLX-T	A1156LLHLX-T	A1193LLHLT-T
A1152LLHLT-T	A1157LLHLT-T	A1193LLHLX-T
A1152LLHLX-T	A1157LLHLX-T	A1194LLHLT-T
A1153ELHLT-T	A1158LLHLT-T	A1194LLHLX-T
A1153LLHLT-T	A1158LLHLX-T	A1244LLHLT-I1-T
A1153LLHLX-T	A1190LLHLT-T	A1244LLHLT-I2-T
A1155LLHLT-T	A1190LLHLX-T	A1244LLHLX-I1-T
A1155LLHLX-T	A1192LLHLT-T	A1244LLHLX-I2-T
<i>Including all finishing suffix variations of the sales roots listed</i>		

**Originator:** Stylianos Kalakonas

**Phone:** 603 626 2484

**Fax:** 603 641 5336

**Duration of Change:**

Permanent

Temporary (explain)

**Summary description of change:** Part Change:

Process Change:

Other:

**1. Dual Assembly Sourcing:**

In 2011 Allegro MicroSystems, LLC qualified a sub-contractor assembly site in Perak, Malaysia for our standard SOT-23W package. In addition, Allegro has installed and qualified a new in-house SOT-23W high-density (HD) assembly line at Allegro Manila, Philippines facility that replicates the line at the subcontractor. The device listed in this PCN will transition from an aging standard SOT-23W assembly line to dual assembly sites using modern equipment and the latest assembly techniques. The transition to a dual source assembly line will allow Allegro to offer our customers additional security of supply.

**2. Top Brand Format Update:**

The format update provides Allegro manufacturing added flexibility and standardization which allows Allegro to better serve customer demand fluctuation.

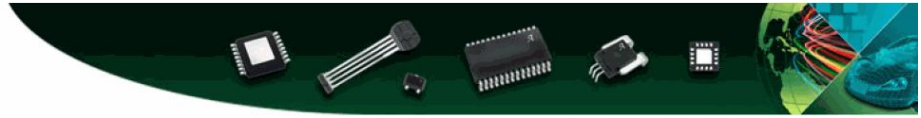

**What is the part or process changing from?**

**1. Assembly Location:**

Existing Allegro standard SOT-23W assembly line located at our facility in Manila, Philippines.

**2. Top Branding**

See attached picture for existing Allegro standard SOT-23W package.

**What is the part or process changing to?**

**1. Assembly Location:**

Dual source SOT-23W (HD) assembly lines located at Allegro’s subcontractor facility in Perak, Malaysia (Carsem) and Allegro’s new line in Manila, Philippines (AMPI). Parts from these two assembly lines are in full compliance with the electrical and dimensional parameters on the existing Allegro published datasheet.

**2. Top Branding**

See attached picture for the Subcontractor and new Allegro SOT-23W (HD) package. Other minor changes in the flow and BOM internal to the package will be provided in the PPAP.

There is no impact on form, fit or function for these part changes.

**Note:** Validation of equivalence within a specific application is at the discretion of the Customer.

**Is a PPAP update required?**

Yes

No

**Reliability testing required?**

Yes

No (explain)

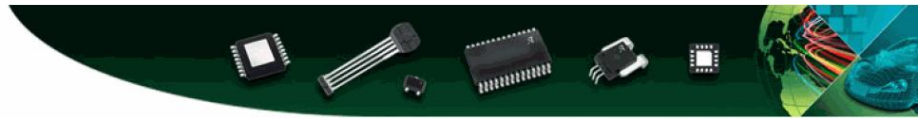

## Package Body Overlay

### Standard SOT-23W vs. SOT-23W (HD)

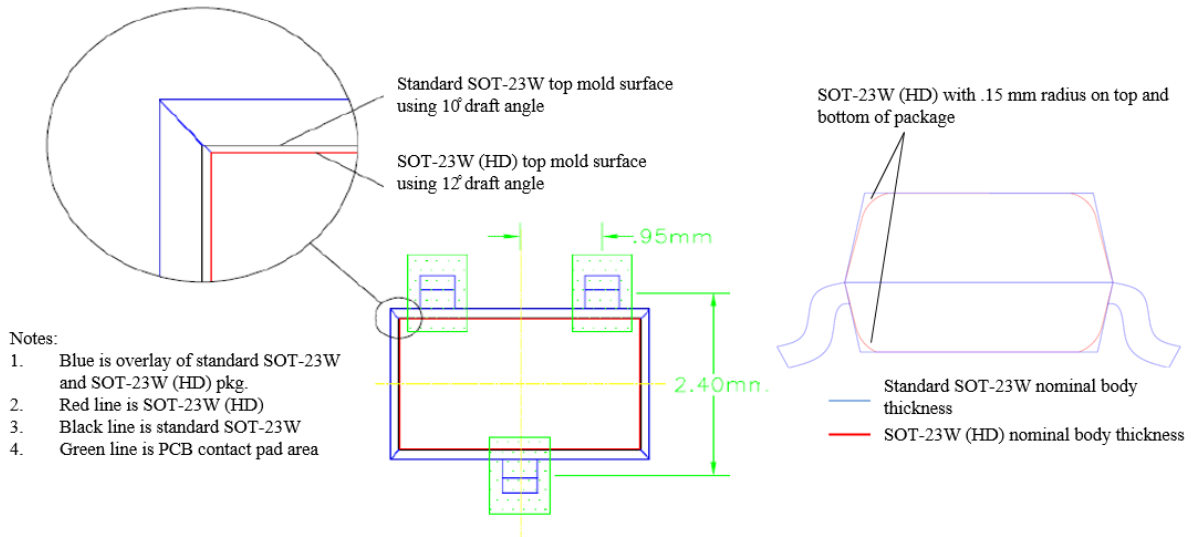

	Standard SOT-23W	SOT-23W (HD)
	Nominal	Nominal
<b>Radii</b>	NA	0.15
<b>Draft angle</b>	10°	12°

Top Brand Comparison	
From: Standard SOT-23W	To: SOT-23W (HD)
<p>Example</p> <p><b>01E</b></p>	<p>Example</p> <p><b>101</b></p>

- **Standard SOT-23W Brand:** Last two digits of part number + Temperature range designator
- **SOT-23W (HD) Brand:** Last three digits of the part number

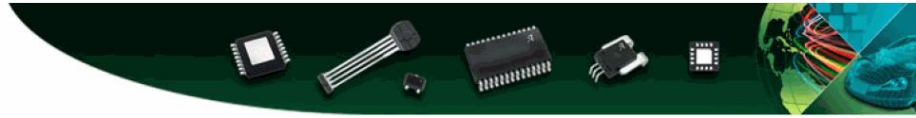

---

**Expected completion date for internal qualification:** Complete

**Expected PPAP availability date:** Upon request + 3 weeks

**Estimated date of first shipment:** April 01, 2016

**Expected sample availability date:** Available upon request

---

**Customer Approval Required:** Yes  **Date Required:**  
No  **Notification Only**

**Please note:** It is our intention to inform our customer of changes as early as possible. Under Allegro's procedure for product/process change notification, Allegro strives, based on its technical judgment, to provide notification of significant changes that may affect form, fit or function. However, as Allegro cannot ensure evaluation of product/process changes for each and every application; the customer retains responsibility to validate the impact of a change on its application suitability. If samples are needed for validation of a change, requests may be made via the contact information provided herein. Please contact your Account Manager or local Sales contact for any questions. We would kindly request your consideration so we can meet our target date for implementation. Unless both parties agree to extend the implementation date, this change will be implemented as scheduled.

cc: Allegro Sales/Marketing/Quality