

## FEATURES

- ±8000 V HBM ESD for shunt-based applications**
- AEC-Q100 qualified**
- EMI filters included**
- High common-mode voltage range**
  - 2 V to +50 V operating
  - 20 V to +70 V survival
- Buffered output voltage**
- Gain = 14 V/V**
- Low-pass filter (single-pole or two-pole)**
- Wide operating temperature range: –40°C to +125°C**
- Excellent ac and dc performance**
  - ±1 mV typical voltage offset
  - 5 ppm/°C typical gain drift
  - 80 dB CMRR minimum dc to 10 kHz
- Qualified for automotive applications**

## APPLICATIONS

- High-side current sensing**
  - Motor controls
  - Solenoid controls
  - Power management
- Low-side current sensing**
- Diagnostic protection**

## GENERAL DESCRIPTION

The [AD8209A](#) is a single-supply difference amplifier ideal for amplifying and low-pass filtering small differential voltages in the presence of a large common-mode voltage. The input common-mode voltage range extends from –2 V to +50 V at a single 5 V supply. The [AD8209A](#) is qualified per AEC-Q100 specifications. The amplifier offers enhanced input overvoltage and ESD protection, and includes electromagnetic interference (EMI) filtering.

## FUNCTIONAL BLOCK DIAGRAM

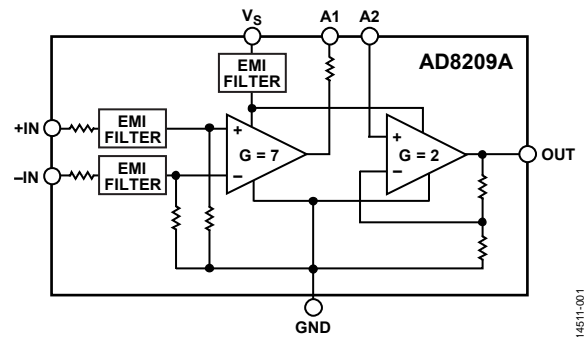

Figure 1.

14611-001

Automotive applications demand robust, precision components for improved system control. The [AD8209A](#) provides excellent ac and dc performance, minimizing errors in the application. Typical offset and gain drift in the MSOP package are less than 5  $\mu\text{V}/^\circ\text{C}$  and –5 ppm/°C, respectively. The device also delivers a minimum common-mode rejection ratio (CMRR) of 80 dB from dc to 10 kHz.

The [AD8209A](#) features an externally accessible 100 k $\Omega$  resistor at the output of the preamplifier (A1) that can be used for low-pass filtering and for establishing gains other than 14 V/V.

# AD8209A\* Product Page Quick Links

Last Content Update: 08/30/2016

---

## [Comparable Parts](#)

View a parametric search of comparable parts

## [Evaluation Kits](#)

- [AD8209A Evaluation Board](#)

## [Documentation](#)

### **Data Sheet**

- [AD8209A: High Voltage, Precision Difference Amplifier Data Sheet](#)

### **User Guides**

- [UG-1024: Evaluation Board User Guide for the AD8209A High Voltage, Precision Difference Amplifier](#)

## [Tools and Simulations](#)

- [AD8209A SPICE Model](#)

## [Design Resources](#)

- [AD8209A Material Declaration](#)
- [PCN-PDN Information](#)
- [Quality And Reliability](#)
- [Symbols and Footprints](#)

## [Discussions](#)

View all AD8209A EngineerZone Discussions

## [Sample and Buy](#)

Visit the product page to see pricing options

## [Technical Support](#)

Submit a technical question or find your regional support number

---

## TABLE OF CONTENTS

Features .....	1	High-Side Current Sensing with a Low-Side Switch .....	11
Applications.....	1	High Rail Current Sensing .....	11
Functional Block Diagram .....	1	Low-Side Current Sensing .....	11
General Description .....	1	Gain Adjustment .....	12
Revision History .....	2	Gain Trim .....	13
Specifications.....	3	Low-Pass Filtering.....	13
Absolute Maximum Ratings.....	4	High Line Current Sensing with Low-Pass Filtering and Gain Adjustment.....	14
ESD Caution.....	4	Outline Dimensions .....	15
Pin Configuration and Function Descriptions.....	5	Ordering Guide .....	15
Typical Performance Characteristics .....	6	Automotive Products.....	15
Theory of Operation .....	10		
Applications Information .....	11		

## REVISION HISTORY

7/2016—Revision 0: Initial Version

## SPECIFICATIONS

Operating temperature ( $T_{OPR}$ ) =  $-40^{\circ}\text{C}$  to  $+125^{\circ}\text{C}$ ,  $T_A = 25^{\circ}\text{C}$ ,  $V_S = 5\text{ V}$ ,  $R_L = 25\text{ k}\Omega$  ( $R_L$  is the output load resistor), unless otherwise noted.

Table 1.

Parameter	Test Conditions/Comments	Min	Typ	Max	Unit
SYSTEM GAIN					
Initial			14		V/V
Error vs. Temperature	$0.075\text{ V} \leq V_{OUT} \leq (V_S - 0.1\text{ V})$ , dc, $T_{OPR}$			$\pm 0.15$	%
Gain Drift	$T_{OPR}$		-5	$\pm 15$	ppm/ $^{\circ}\text{C}$
VOLTAGE OFFSET					
Initial Input Offset (Referred to Input (RTI))	Input common-mode voltage ( $V_{CM}$ ) = $0.15\text{ V}$ , at $T_A$		$\pm 1$	$\pm 2$	mV
Input Offset (RTI) over Temperature	$V_{CM} = 0\text{ V}$ , $T_{OPR}$			$\pm 4$	mV
Voltage Offset vs. Temperature	$V_{CM} = 0\text{ V}$ , $T_{OPR}$	-20		+20	$\mu\text{V}/^{\circ}\text{C}$
INPUT					
Input Impedance					
Differential		360	400	440	k $\Omega$
Common Mode		180	200	220	k $\Omega$
$V_{CM}$ (Continuous)		-2		+50	V
CMRR <sup>1</sup>	$V_{CM} = -2\text{ V}$ to $+50\text{ V}$ , dc $f = \text{dc}$ to $10\text{ kHz}$ , <sup>2</sup> $T_{OPR}$	80	100		dB
		80			dB
PREAMPLIFIER (A1)					
Gain			7		V/V
Gain Error	$0.0375\text{ V} \leq V_{OUT} \leq (V_S - 0.1\text{ V})$ , dc, $T_{OPR}$	-0.3		+0.3	%
Output Voltage Range		0.025		$V_S - 0.1$	V
Output Resistance		97	100	103	k $\Omega$
OUTPUT BUFFER (A2)					
Gain			2		V/V
Gain Error	$0.075\text{ V} \leq V_{OUT} \leq (V_S - 0.1\text{ V})$ , dc, $T_{OPR}$	-0.3		+0.3	%
Output Voltage Range <sup>3,4</sup>	$R_L = 25\text{ k}\Omega$ , differential input = $0\text{ V}$ , $T_{OPR}$ ; Pin 3 (A1 output) driving Pin 4 (A2 input)	0.05		$V_S - 0.1$	V
Output Voltage Range <sup>5</sup>	Pin 4 (A2 input) driven with an external source	0.05		$V_S - 0.1$	V
Input Bias Current	$T_{OPR}$			50	nA
Output Resistance	$R_L = 1\text{ k}\Omega$ , frequency = dc		2		$\Omega$
DYNAMIC RESPONSE					
System Bandwidth	$V_{IN} = 0.01\text{ V p-p}$ , $V_{OUT} = 0.14\text{ V p-p}$		100		kHz
Slew Rate	$V_{IN} = 0.28\text{ V}$ , $V_{OUT} = 4\text{ V}$ step		1		V/ $\mu\text{s}$
NOISE					
0.1 Hz to 10 Hz			20		$\mu\text{V p-p}$
Spectral Density, 1 kHz (RTI)			500		nV/ $\sqrt{\text{Hz}}$
POWER SUPPLY					
Operating Range		4.5		5.5	V
Quiescent Current	Typical at $T_A$		1.6		mA
Quiescent Current vs. Temperature	$V_{OUT} = 0.1\text{ V}$ dc, $V_S = 5\text{ V}$ , $T_{OPR}$			2.7	mA
Power Supply Rejection Ratio (PSRR)	$V_S = 4.5\text{ V}$ to $5.5\text{ V}$ , $T_{OPR}$	70	80		dB
TEMPERATURE RANGE	For specified performance at $T_{OPR}$	-40		+125	$^{\circ}\text{C}$

<sup>1</sup> Source imbalance <  $2\ \Omega$ .

<sup>2</sup> The AD8209A preamplifier exceeds 80 dB CMRR at 10 kHz. However, because the output is available only via the 100 k $\Omega$  resistor, even a small amount of pin to pin capacitance between the  $\pm\text{IN}$  pins and the A1 and A2 pins may couple an input common-mode signal larger than the greatly attenuated preamplifier output. The effect of pin to pin coupling can be neglected in all applications by using a filter capacitor from Pin 3 to GND.

<sup>3</sup> The output voltage range of the AD8209A varies depending on the load resistance and temperature. For additional information on this specification, refer to Figure 12 and Figure 13.

<sup>4</sup> The output voltage range of A2 assumes that Pin 3 (A1 output) and Pin 4 (A2 input) are shorted together. A 25 k $\Omega$  load resistor is used for testing.

<sup>5</sup> The output voltage range of A2 assumes Pin 4 (A2 input) is driven with an external voltage source. A 25 k $\Omega$  load resistor is used for testing.

## ABSOLUTE MAXIMUM RATINGS

Table 2.

Parameter	Rating
Supply Voltage	9 V
Continuous Input Voltage (Common Mode)	-20 V to +70 V
Differential Input Voltage	±16 V
Reversed Supply Voltage Protection	0.3 V
ESD Human Body Model for Shunt-Based Applications <sup>1</sup>	±8000 V
Operating Temperature Range	-40°C to +125°C
Storage Temperature Range	-65°C to +150°C
Output Short-Circuit Duration	Indefinite
Lead Temperature Range (Soldering 10 sec)	300°C

<sup>1</sup> Shunt-based applications have a low impedance shunt resistor between +IN and -IN. See Figure 24 for an example of a shunt-based application.

Stresses at or above those listed under Absolute Maximum Ratings may cause permanent damage to the product. This is a stress rating only; functional operation of the product at these or any other conditions above those indicated in the operational section of this specification is not implied. Operation beyond the maximum operating conditions for extended periods may affect product reliability.

### ESD CAUTION



**ESD (electrostatic discharge) sensitive device.** Charged devices and circuit boards can discharge without detection. Although this product features patented or proprietary protection circuitry, damage may occur on devices subjected to high energy ESD. Therefore, proper ESD precautions should be taken to avoid performance degradation or loss of functionality.

# PIN CONFIGURATION AND FUNCTION DESCRIPTIONS

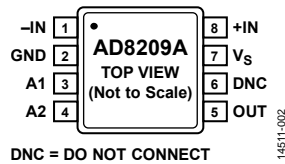

Figure 2. Pin Configuration

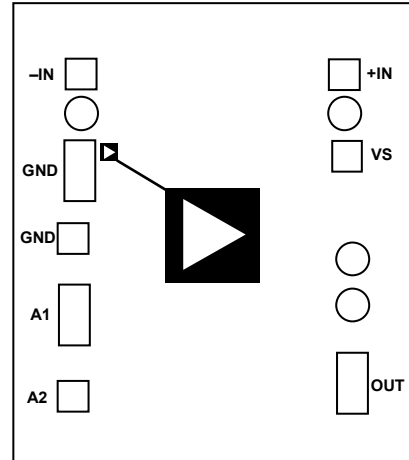

Figure 3. Metallization Photograph

Table 3. Pin Function Descriptions<sup>1</sup>

Pin No.	Mnemonic	Coordinates		Size (µm)	Description
		X	Y		
1	-IN	-305	+375	70 × 70	Inverting Input.
N/A	OPEN	-305	+282	70 × 70	Bond pads are not connected to any external pins.
2	GND	-309	+149	70 × 142	Ground.
2	GND	-326	-7	70 × 70	Ground.
3	A1	-321	-185	70 × 142	Preamplifier (A1) Output.
4	A2	-321	-375	70 × 70	Buffer (A2) Input.
5	OUT	+321	-345	70 × 142	Buffer (A2) Output.
N/A	OPEN	+322	-162	70 × 70	No Connect.
N/A	OPEN	+327	-54	70 × 70	Bond pads are not connected to any external pins.
6	DNC	Not applicable	Not applicable	Not applicable	Do Not Connect. Do not connect to this pin; Pin 6 does not connect to any bond pads.
7	V <sub>S</sub>	+309	+185	70 × 70	Supply.
N/A	OPEN	+305	+375	70 × 70	Bond pads are not connected to any external pins.
8	+IN	+305	+282	70 × 70	Noninverting Input.

<sup>1</sup> N/A means not applicable.

# TYPICAL PERFORMANCE CHARACTERISTICS

$T_{OPR} = -40^{\circ}\text{C}$  to  $+125^{\circ}\text{C}$ ,  $T_A = 25^{\circ}\text{C}$ ,  $V_S = 5\text{ V}$ ,  $R_L = 25\text{ k}\Omega$  ( $R_L$  is the output load resistor), unless otherwise noted.

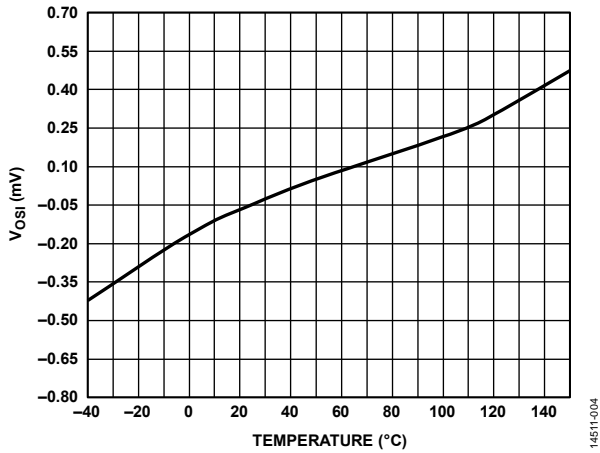

Figure 4. Offset ( $V_{OSI}$ ) vs. Temperature

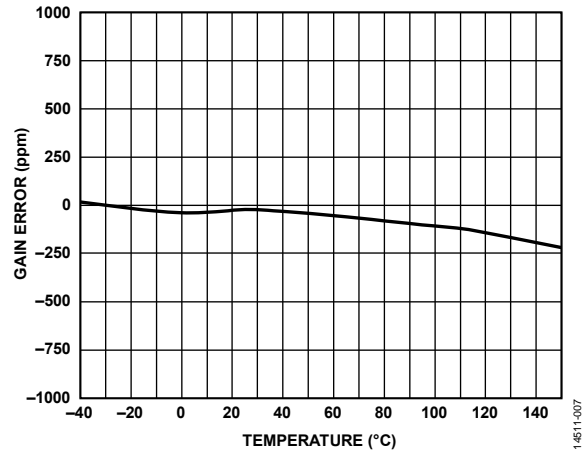

Figure 7. Gain Error vs. Temperature

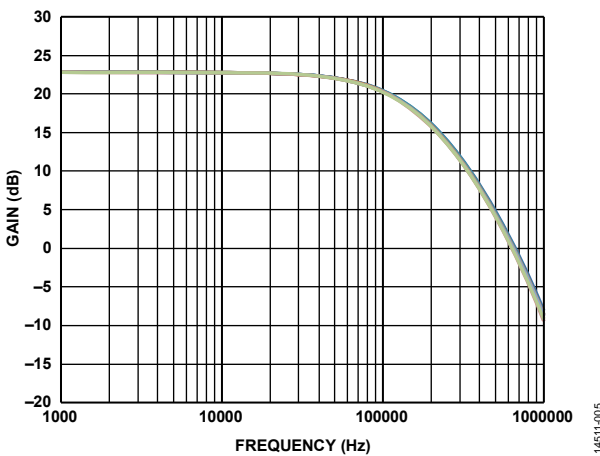

Figure 5. Small Signal Bandwidth

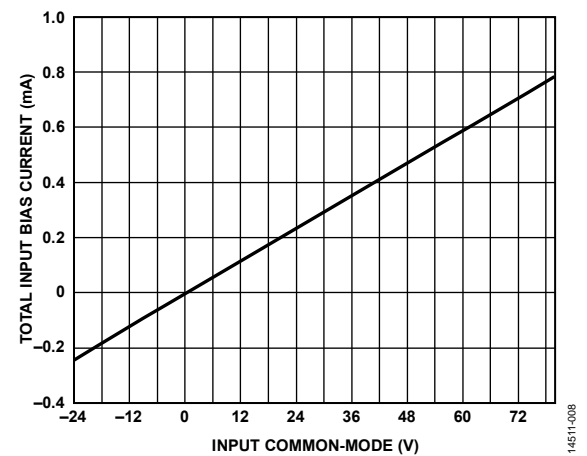

Figure 8. Total Input Bias Current vs. Input Common-Mode Voltage,  $+IN$  and  $-IN$  Pins Connected (Shorted)

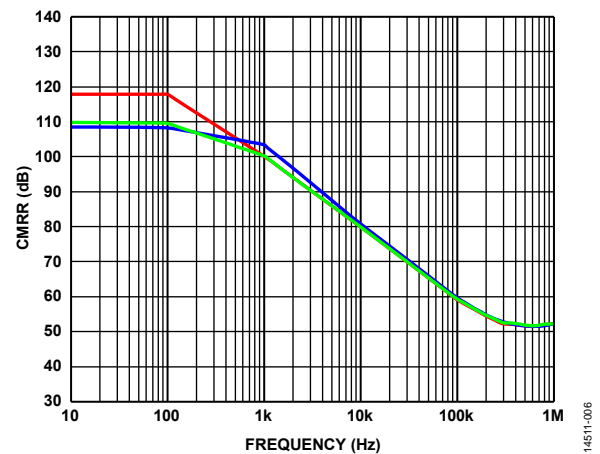

Figure 6. CMRR vs. Frequency

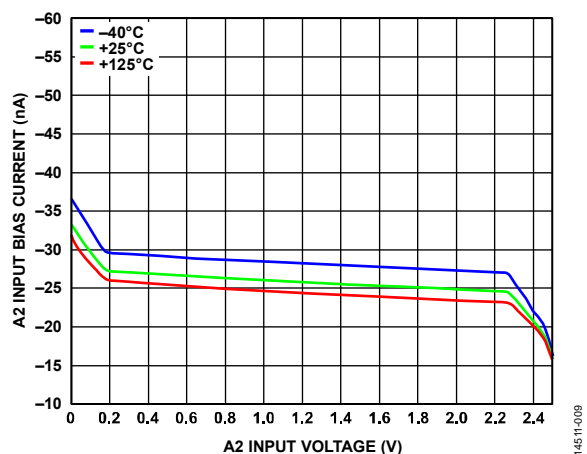

Figure 9. A2 Input Bias Current vs. A2 Input Voltage and Temperature

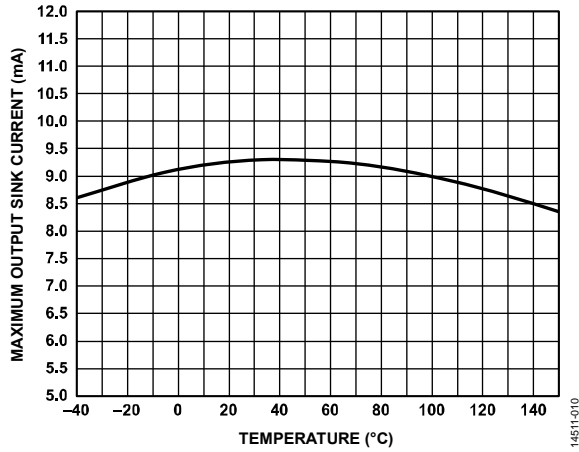

Figure 10. Maximum Output Sink Current vs. Temperature

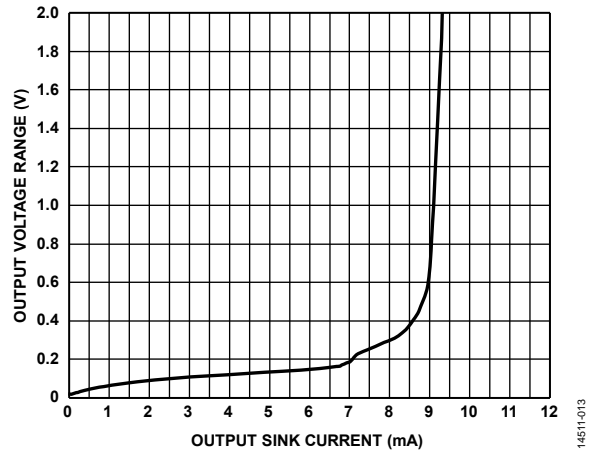

Figure 13. A2 Output Voltage Range from GND vs. Output Sink Current

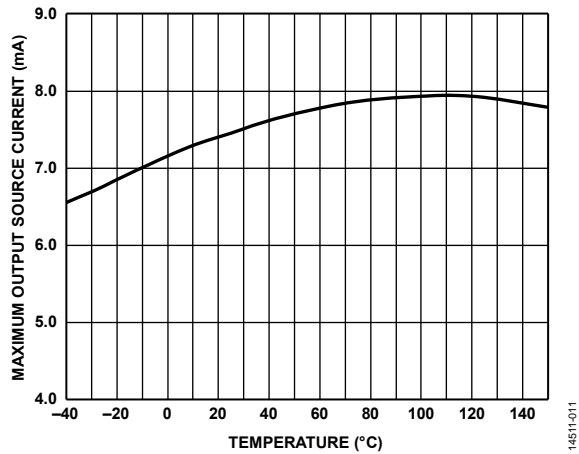

Figure 11. Maximum Output Source Current vs. Temperature

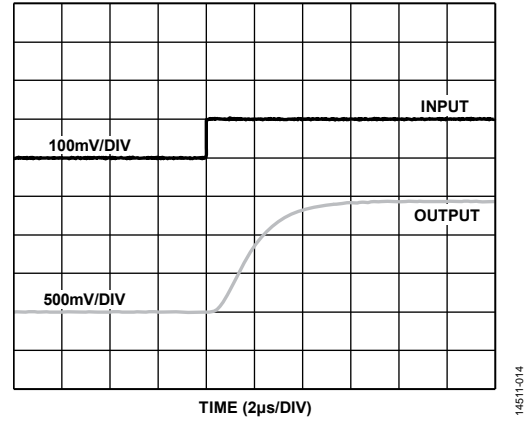

Figure 14. Rise Time

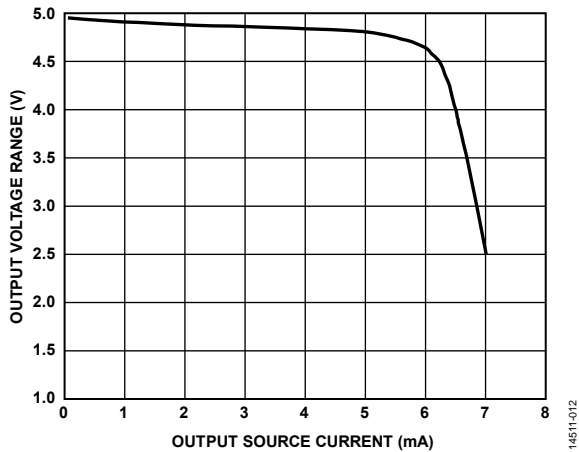

Figure 12. A2 Output Voltage Range vs. Output Source Current

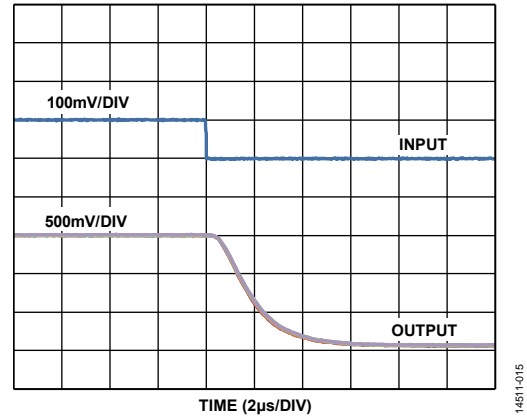
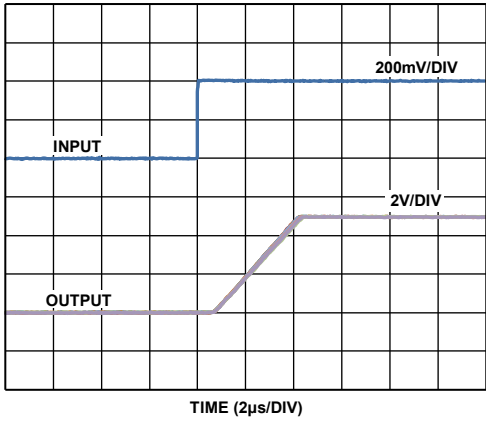

Figure 15. Fall Time





14511-016

Figure 16. Differential Overload Recovery, Rising

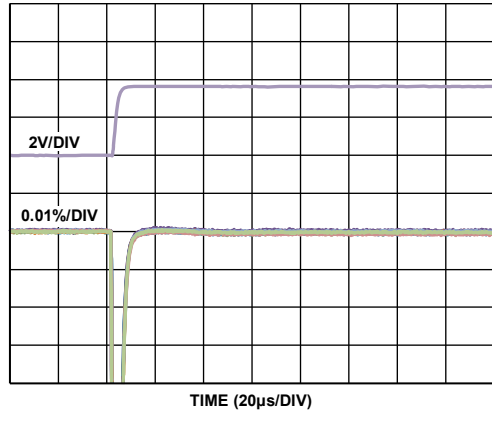

14511-018

Figure 18. Settling Time, Rising

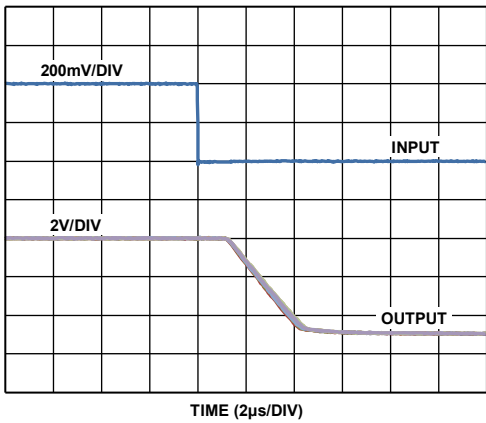

14511-017

Figure 17. Differential Overload Recovery, Falling

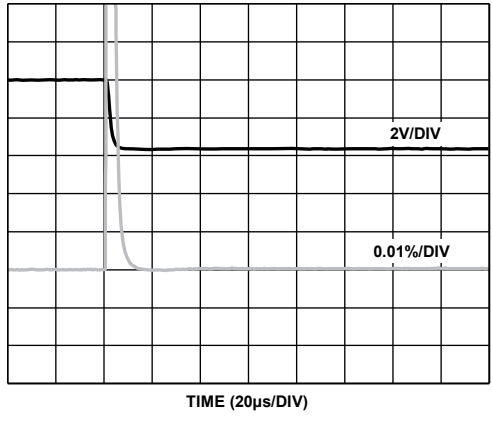

14511-019

Figure 19. Settling Time, Falling

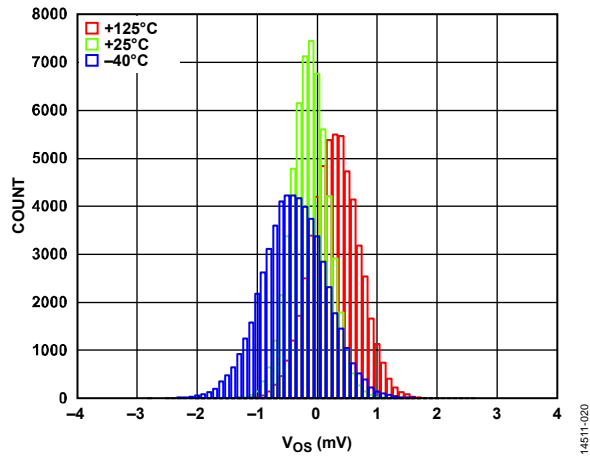

Figure 20. Offset Distribution

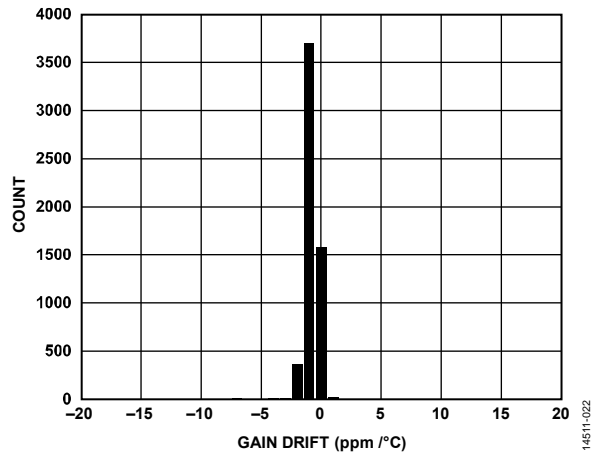

Figure 22. Gain Drift Distribution

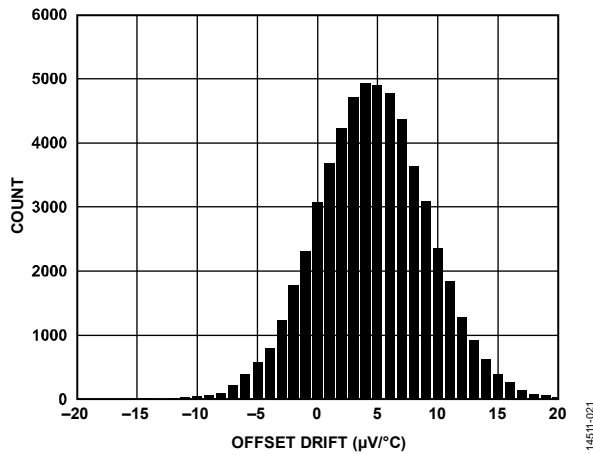

Figure 21. Offset Drift Distribution

14511-020

14511-022

14511-021

## THEORY OF OPERATION

The AD8209A is a single-supply difference amplifier typically used to amplify a small differential voltage in the presence of rapidly changing, high common-mode voltages.

The AD8209A consists of two amplifiers (A1 and A2), a resistor network, a small voltage reference, and a bias circuit (not shown); see Figure 23.

The set of input attenuators preceding A1 consist of  $R_A$ ,  $R_B$ , and  $R_C$ , which feature a combined series resistance of approximately  $400\text{ k}\Omega \pm 20\%$ . The purpose of these resistors is to attenuate the input voltage to match the input voltage range of A1. This balanced resistor network attenuates the common-mode signal by a ratio of 1/14. The A1 amplifier inputs are held within the power supply range, even as Pin 1 and Pin 8 exceed the supply or fall below the common (ground). A reference voltage of 350 mV biases the attenuator above ground, allowing Amplifier A1 to operate in the presence of negative common-mode voltages.

The input resistor network also attenuates normal (differential) mode voltages. Therefore, A1 features a gain of 97 V/V to provide a total system gain, from  $\pm\text{IN}$  to the output of A1, equal to 7 V/V, as shown in the following equation:

$$\text{Gain (A1)} = 1/14 (\text{V/V}) \times 97 (\text{V/V}) = 7 \text{ V/V}$$

A precision trimmed, 100 k $\Omega$  resistor is placed in series with the output of Amplifier A1. The user has access to this resistor via an external pin (A1). A low-pass filter can be easily implemented

by connecting A1 to A2 and placing a capacitor to ground (see Figure 32).

The value of  $R_{F1}$  and  $R_{F2}$  is 10 k $\Omega$ , providing a gain of 2 V/V for Amplifier A2. When connecting Pin A1 and Pin A2 together, the AD8209A provides a total system gain equal to

*Total Gain of (A1 + A2) (V/V) = 7 (V/V)  $\times$  2 (V/V) = 14 V/V* at the output of A2 (the OUT pin).

The ratios of  $R_A$ ,  $R_B$ ,  $R_C$ , and  $R_F$  are trimmed to a high level of precision, allowing a typical CMRR value that exceeds 80 dB. This performance is accomplished by laser trimming the resistor ratio matching to better than 0.01%.

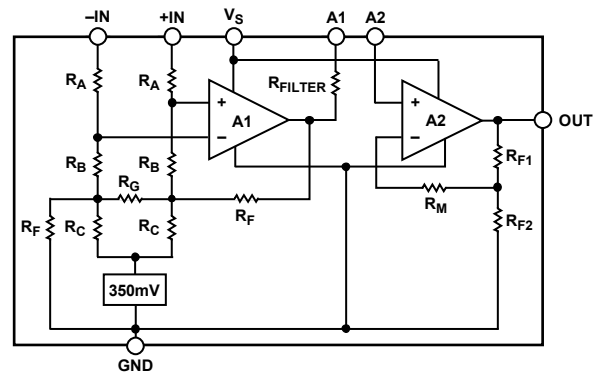

Figure 23. Simplified Schematic

14511-025

## APPLICATIONS INFORMATION

### HIGH-SIDE CURRENT SENSING WITH A LOW-SIDE SWITCH

In load control configurations for high-side current sensing with a low-side switch, the pulse-width modulation (PWM) controlled switch is ground referenced. An inductive load (solenoid) connects to a power supply/battery. A resistive shunt is placed between the switch and the load (see Figure 24). An advantage of placing the shunt on the high side is that the entire current, including the recirculation current, is monitored because the shunt remains in the loop when the switch is off. In addition, shorts to ground can be detected with the shunt on the high side, enhancing the diagnostics of the control loop. In this circuit configuration, when the switch is closed, the common-mode voltage moves down to near the negative rail. When the switch is opened, the voltage reversal across the inductive load causes the common-mode voltage to be held one diode drop above the battery by the clamp diode.

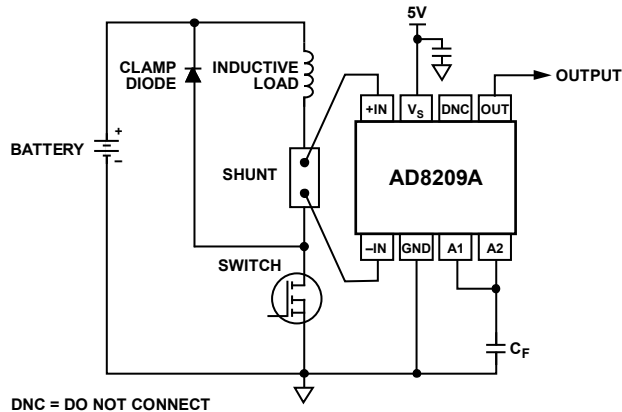

Figure 24. Low-Side Switch

In cases where a high-side switch is used for PWM control of the load current in an application, the AD8209A can be used as shown in Figure 25. The recirculation current through the freewheeling diode (clamp diode) is monitored through the shunt resistor. In this configuration, the common-mode voltage in the application drops below GND when the FET is switched off. The AD8209A operates down to  $-2\text{ V}$ , providing an accurate current measurement.

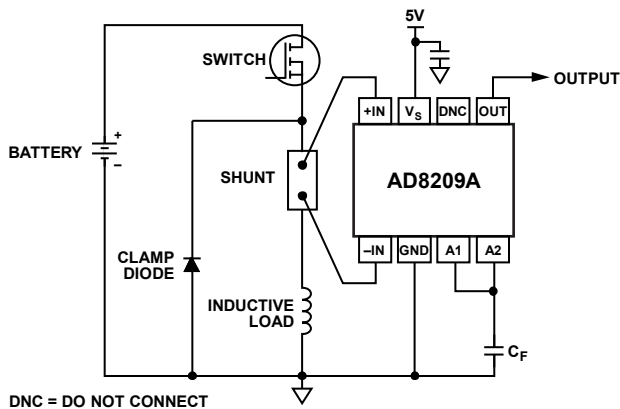

Figure 25. High-Side Switch

### HIGH RAIL CURRENT SENSING

In the high rail current sensing configuration, the shunt resistor is referenced to the battery. High voltage is present at the inputs of the current sense amplifier. When the shunt is battery referenced, the AD8209A produces a linear ground-referenced analog output. Additionally, the AD8214 can be used to provide an overcurrent detection signal in as little as 100 ns (see Figure 26). This feature is useful in high current systems where fast shutdown in overcurrent conditions is essential.

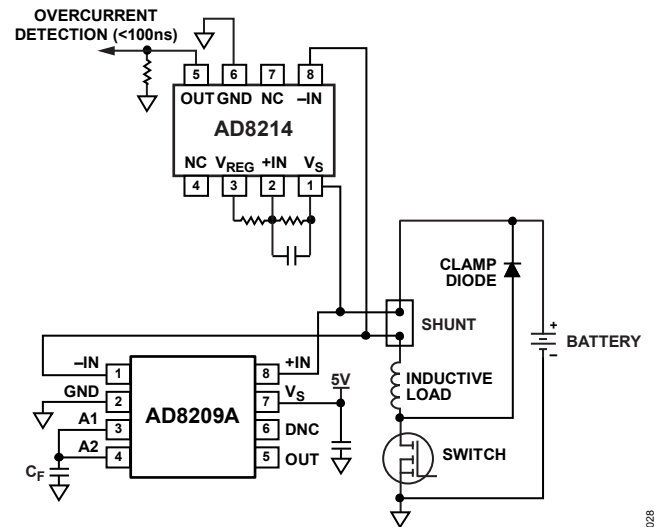

Figure 26. Battery Referenced Shunt Resistor

### LOW-SIDE CURRENT SENSING

In systems where low-side current sensing is preferable, the AD8209A provides a simple, high accuracy, integrated solution. In this configuration, the AD8209A rejects ground noise and offers high input to output linearity, regardless of the differential input voltage.

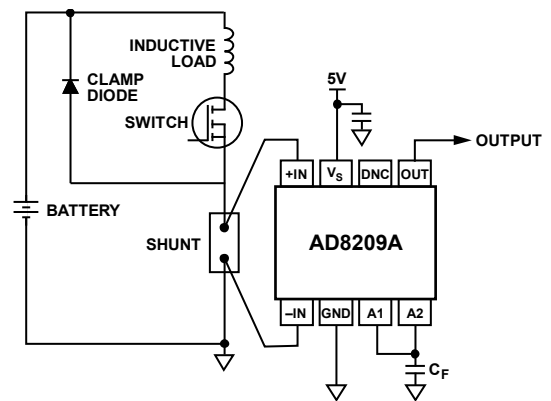
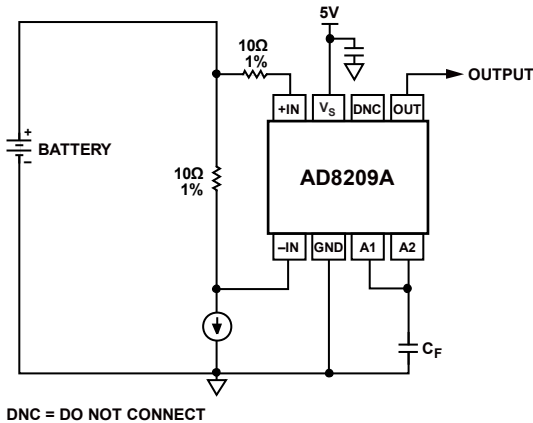

Figure 27. Ground Referenced Shunt Resistor

**4 mA to 20 mA Current Loop Receiver**

The AD8209A can also be used in low current sensing applications, such as the 4 mA to 20 mA current loop receiver shown in Figure 28. In such applications, the relatively large shunt resistor may degrade the common-mode rejection. Adding a resistor of equal value on the low impedance side of the input corrects this error.



DNC = DO NOT CONNECT

Figure 28. 4 mA to 20 mA Current Loop Receiver

14511-030

**GAIN ADJUSTMENT**

The default gain of the preamplifier and buffer are 7 V/V and 2 V/V, respectively, resulting in a composite gain of 14 V/V. With the addition of external resistor(s) or trimmer(s), the gain can be lowered, raised, or finely calibrated.

**Gains Less than 14**

Because the preamplifier has an output resistance of 100 kΩ, an external resistor connected from Pin 3 and Pin 4 to GND decreases the gain by the following factor (see Figure 29):

$$R_{EXT} / (100\text{ k}\Omega + R_{EXT})$$

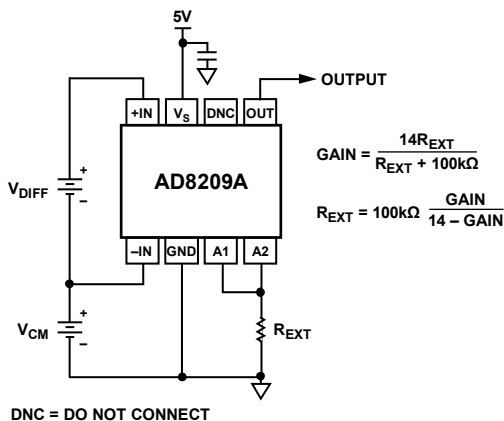

DNC = DO NOT CONNECT

Figure 29. Adjusting for Gains Less than 14

14511-031

The overall bandwidth is unaffected by changes in gain by using this method, although there may be a small offset voltage due to the imbalance in source resistances at the input to the buffer. In many cases, this offset voltage can be ignored, but if desired, the offset voltage can be nulled by inserting a resistor in series with Pin 4. It is recommended that the resistor used be equal to 100 kΩ minus the parallel sum of R<sub>EXT</sub> and 100 kΩ. For example, with R<sub>EXT</sub> = 100 kΩ (yielding a composite gain of 7 V/V), the optional offset nulling resistor is 50 kΩ.

**Gains Greater than 14**

Connecting a resistor from the output of the buffer amplifier to its noninverting input, as shown in Figure 30, increases the gain. The gain is now multiplied by the factor

$$R_{EXT} / (R_{EXT} - 100\text{ k}\Omega)$$

For example, it is doubled for R<sub>EXT</sub> = 200 kΩ. Overall gains as high as 50 are achievable in this way. Note that the accuracy of the gain becomes critically dependent on the resistor value at high gains. In addition, the effective input offset voltage at Pin 1 and Pin 8 (which is about six times the actual offset of A1) limits the use of the device in high gain, dc-coupled applications.

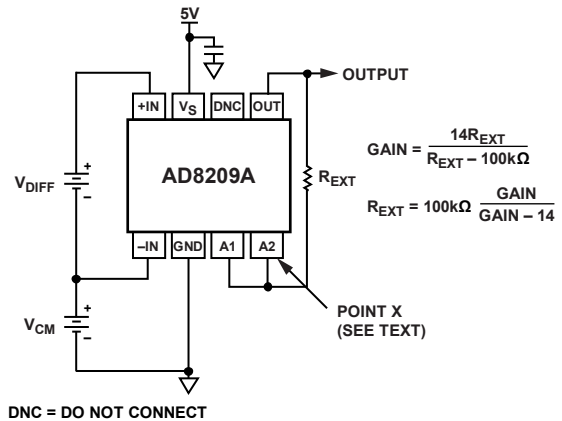

DNC = DO NOT CONNECT

Figure 30. Adjusting for Gains Greater than 14

14511-032

A small offset voltage arises from an imbalance in source resistances and the finite bias currents inherently present at the input of A2. In most applications, this additional offset error is comparable to the specified offset range and therefore introduces negligible skew. However, it can be essentially eliminated by the addition of a resistor in series with the parallel combination of R<sub>EXT</sub> and 100 kΩ (at Point X in Figure 30) so that the total resistance is maintained at 100 kΩ. For example, at a gain of 20, when R<sub>EXT</sub> = 332 kΩ and the parallel combination of R<sub>EXT</sub> and 100 kΩ is 77 kΩ, the series resistor placed at Point X is 23 kΩ.

**GAIN TRIM**

Figure 31 shows a method for incremental gain trimming by using a trim potentiometer and an external resistor,  $R_{EXT}$ .

The following approximation is useful for small gain ranges:

$$\Delta G \approx (10 \text{ M}\Omega \div R_{EXT})\%$$

For example, using this equation, the adjustment range is  $\pm 2\%$  for  $R_{EXT} = 5 \text{ M}\Omega$  and  $\pm 10\%$  for  $R_{EXT} = 1 \text{ M}\Omega$ .

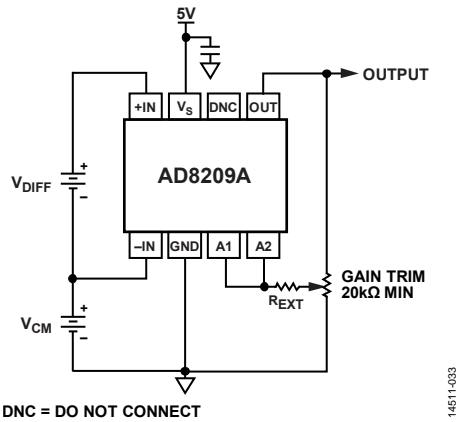

Figure 31. Incremental Gain Trimming

**Internal Signal Overload Considerations**

When configuring the gain for values other than 14, the maximum input voltage with respect to the supply voltage and ground must be considered because either the preamplifier or the output buffer reaches its full-scale output ( $V_S - 0.1 \text{ V}$ ) with large differential input voltages. The input of the AD8209A is limited to  $(V_S - 0.1) \div 7$  for overall gains of  $\leq 7$  because the preamplifier, with its fixed gain of 7 V/V, reaches its full-scale output before the output buffer.

For gains greater than 7, the swing at the buffer output reaches its full scale first and then limits the AD8209A input to  $(V_S - 0.1) \div G$ , where G is the overall gain.

**LOW-PASS FILTERING**

In many transducer applications, it is necessary to filter the signal to remove spurious high frequency components, including noise, or to extract the mean value of a fluctuating signal with a peak to average ratio (PAR) greater than unity. For example, a full wave rectified sinusoid has a PAR of 1.57, a raised cosine has a PAR of 2, and a half wave sinusoid has a PAR of 3.14. Signals with large spikes may have PARs of 10 or more.

When implementing a filter, consider the PAR so that the output of the AD8209A preamplifier (A1) does not clip before A2; otherwise, the nonlinearity is averaged and appears as an error at the output. To avoid this error, both amplifiers clip at the same time. This condition is achieved when the PAR is no greater than the gain of the second amplifier (2 for the default configuration). For example, if a PAR of 5 is expected, increase the gain of A2 to 5.

Low-pass filters can be implemented in several ways by using the features provided by the AD8209A. In the simplest case, a single-pole filter (20 dB/decade) is formed when the output of A1 is connected to the input of A2 via the internal 100 kΩ resistor by tying Pin 3 to Pin 4 and adding a capacitor from this node to ground, as shown in Figure 32. If a resistor is added across the capacitor to lower the gain, the corner frequency increases; therefore, calculate the gain using the parallel sum of the resistor and 100 kΩ.

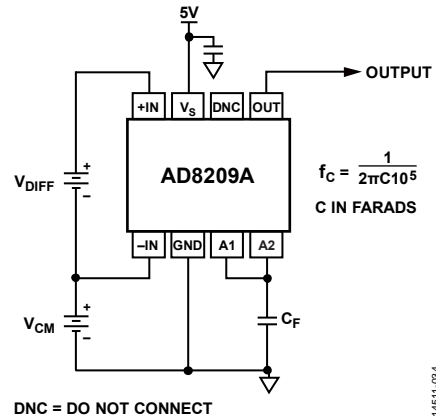

Figure 32. Single-Pole, Low-Pass Filter Using the Internal 100 kΩ Resistor

If the gain is raised using a resistor, as shown in Figure 30, the corner frequency is lowered by the same factor as the gain is raised. Therefore, using a resistor of 200 kΩ (for which the gain is doubled), results in a corner frequency scaled to 0.796 Hz/μF (0.039 μF for a 20 Hz corner frequency).

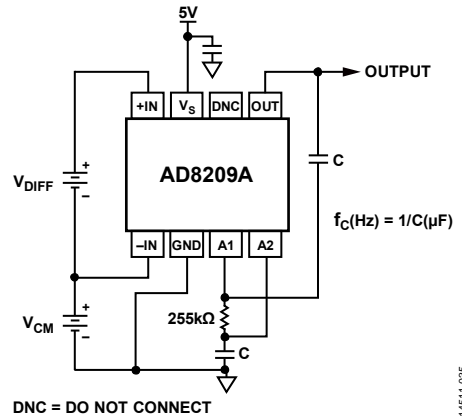

Figure 33. Two-Pole, Low-Pass Filter

A two-pole filter with a roll-off of 40 dB/decade can be implemented using the connections shown in Figure 33. This configuration is a Sallen-Key form based on a  $\times 2$  amplifier. A two-pole filter with a corner frequency of  $f_2$  and a single-pole filter with a corner frequency of  $f_1$  have the same attenuation, that is,  $40 \log (f_2/f_1)$ , as shown in Figure 34. Using the standard resistor value shown in Figure 33 and capacitors of equal values, the corner frequency is conveniently scaled to 1 Hz/μF (0.05 μF for a 20 Hz corner frequency). A maximal flat response occurs when the resistor is lowered to 196 kΩ, scaling the corner

frequency to  $1.145 \text{ Hz}/\mu\text{F}$ . The output offset is raised by approximately  $5 \text{ mV}$  (equivalent to  $250 \mu\text{V}$  at the input pins).

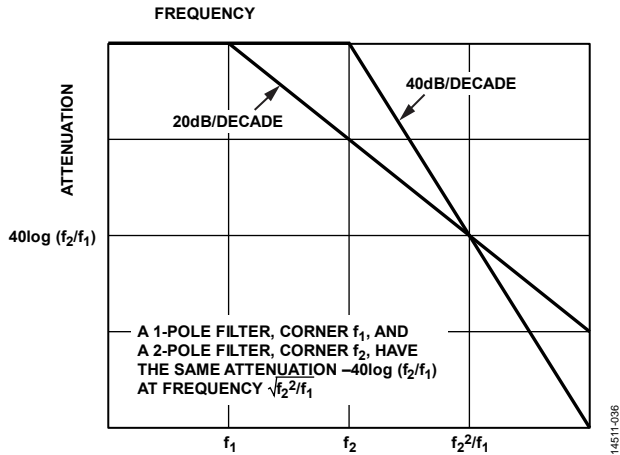

Figure 34. Comparative Responses of Single-Pole and Two-Pole Low-Pass Filters

### HIGH LINE CURRENT SENSING WITH LOW-PASS FILTERING AND GAIN ADJUSTMENT

The circuit shown in Figure 35 is similar to Figure 24, but includes gain adjustment and low-pass filtering.

A power device that is either on or off controls the current in the load. The average current is proportional to the duty cycle of the input pulse and is sensed by a small value resistor. The average differential voltage across the shunt is typically  $100 \text{ mV}$ , although its peak value is higher by an amount that depends on the inductance of the load and the control frequency. The common-mode voltage, on the other hand, extends from roughly  $1 \text{ V}$  above ground for the on condition to about  $1.5 \text{ V}$  above the battery voltage in the off condition. The conduction of the clamping diode regulates the common-mode potential applied to the device. For example, a battery spike of  $20 \text{ V}$  may result in an applied common-mode potential of  $21.5 \text{ V}$  to the input of the devices.

To produce a full-scale output of  $4 \text{ V}$ , a gain of  $40 \text{ V/V}$  is used, adjustable by  $\pm 5\%$  to absorb the tolerance in the shunt. There is sufficient headroom to allow  $10\%$  overrange (to  $4.4 \text{ V}$ ). The roughly triangular voltage across the sense resistor is averaged by a single-pole, low-pass filter that is set with a corner frequency of  $3.6 \text{ Hz}$ , which provides about  $30 \text{ dB}$  of attenuation at  $100 \text{ Hz}$ . A higher rate of attenuation can be obtained by using a two-pole filter with a corner frequency of  $20 \text{ Hz}$ , as shown in Figure 36. Although this circuit uses two separate capacitors, the total capacitance is less than half of what is needed for the single-pole filter.

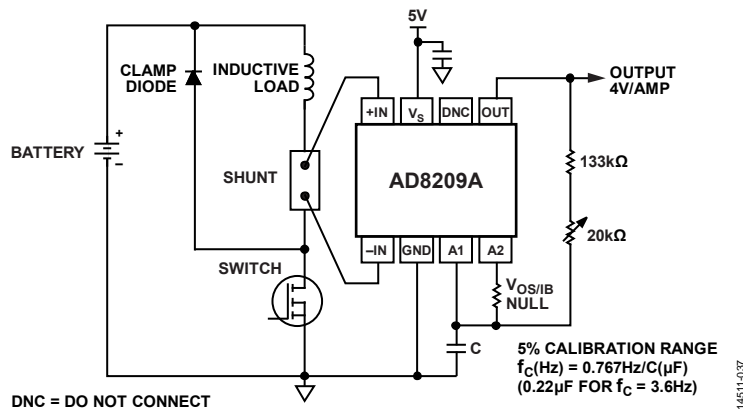

Figure 35. High Line Current Sensor Interface; Gain =  $40 \text{ V/V}$ , Single-Pole, Low-Pass Filter

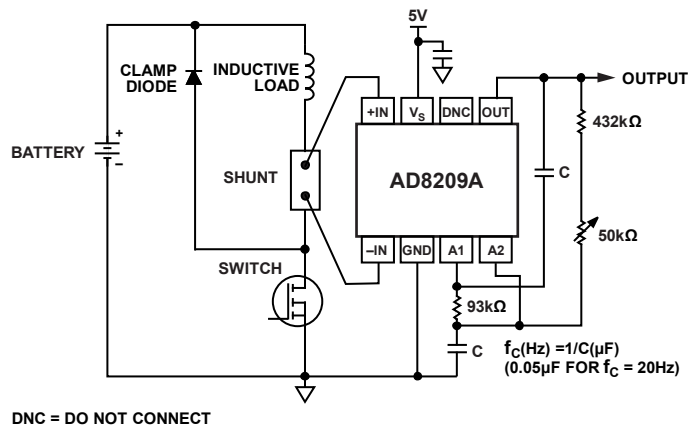
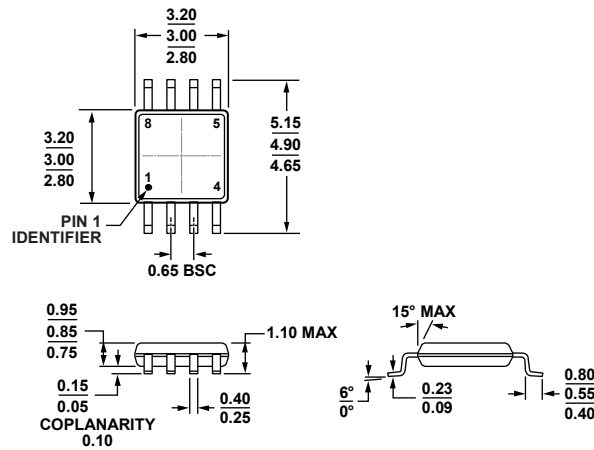

Figure 36. Two-Pole Low-Pass Filter

### OUTLINE DIMENSIONS



COMPLIANT TO JEDEC STANDARDS MO-187-AA

Figure 37. 8-Lead Mini Small Outline Package [MSOP] (RM-8)

Dimensions shown in millimeters

### ORDERING GUIDE

Model <sup>1,2</sup>	Temperature Range	Package Description	Package Option	Branding
AD8209AWBRMZ	-40°C to +125°C	8-Lead Mini Small Outline Package [MSOP]	RM-8	Y5X
AD8209AWBRMZ-R7	-40°C to +125°C	8-Lead Mini Small Outline Package [MSOP]	RM-8	Y5X
AD8209AWBRMZ-RL	-40°C to +125°C	8-Lead Mini Small Outline Package [MSOP]	RM-8	Y5X
AD8209A-EVALZ		Evaluation Board		

<sup>1</sup> Z = RoHS Compliant Part.

<sup>2</sup> W = Qualified for Automotive Applications.

### AUTOMOTIVE PRODUCTS

The [AD8209AW](#) models are available with controlled manufacturing to support the quality and reliability requirements of automotive applications. Note that these automotive models may have specifications that differ from the commercial models; therefore, designers should review the Specifications section of this data sheet carefully. Only the automotive grade products shown are available for use in automotive applications. Contact your local Analog Devices account representative for specific product ordering information and to obtain the specific Automotive Reliability reports for these models.