

Stepper gearmotor Data sheet

82 924 043
ratio 250

Series
829240

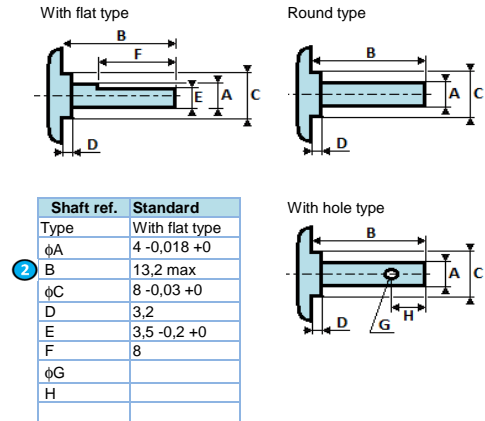
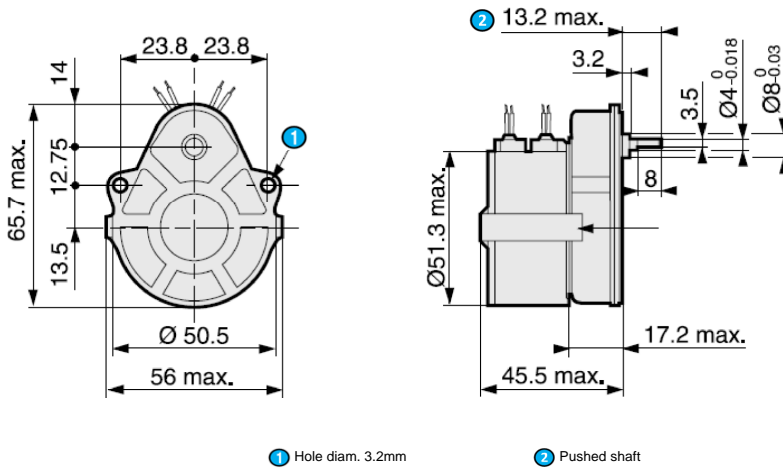

Product

Code	82 924 043		
Family	82924		
Type	Stepper gearmotor		
Definition	Motor 82920 1,7W 500 rpm nominal 7,5 °/t 48 step/t + Gearbox Ovoide ratio 250	2 phases 10,7 Ohms/phase	

General characteristics

Motor characteristics (1)	
Motor type	829200
Number of phases	2
Input power	W 7,5
Phase resistor	Ohm 10,7
Phase inductance	Mh 24
Phase current	A 0,59
Maintain torque	mNm 70
Voltage per phase	Vcc 6,3
Step angle	deg 7,5
Step precision	% 5
Rotor inertia	g.cm ² 18,8
Max. detent torque	mNm 6
Weight	g 210
Output leads	
UL style 1569 105°C 300V - 4 leads AWG24	250 mm +- 10

Gearmotor characteristics (1) (2)		A	B	C	D
Additional resistor /phase	Ohm	0	10,7	21,4	32,1
Voltage (phase + add. resistor)	Vcc	6,3	12,6	18,9	25,2
Max. output power	W	0,49	0,84	1,12	1,41
Speed at max. output power	rpm	0,9	1,3	1,5	1,9
Torque at max. output power	Nm	5,30	6,62	7,13	7,19
Max. current	A	0,59			
Weight	g	140			
Noise level	dBA	35			
Motor fixing on gearbox		✓ Clip		Screws	
Miscellaneous					
Dielectric (1s/2mA/50Hz)	CEI60335	Vac	600		
Motor insulation	CEI60085	class	B		
Degree of protection	CEI60529	IP	40		
Temperature range	CEI60068-2-1/2	°C	-30 -> +70		
Storage temperature		°C	-40 -> +80		
Approvals					
ROHS	2011/65/UE		✓		
EC	2014/30/UE		✓		

Notes	
Values without tolerance, are average production values.	
(1) Cold motor, 20 ° C ambient temperature, full speed	
(2) Without taking in count the torque gearbox limits, check gearbox characteristics	
(3) Continuously rated torque, zero radial and axial loads	
(4) Max torque for continuous operation at 20 ° C, decrease this value for higher ambient temperature	

Command sequence

Drive sequence for Clock Wise rotation

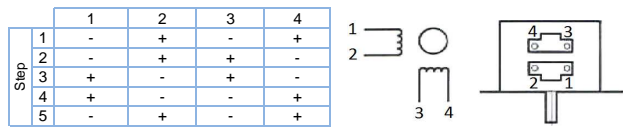

Gearbox Characteristics

Type	Ovoide	81021
ratio	250	
Shaft	standard	
Front bearing	Brass	
Continuous max. torque	Nm	0,5
Max. Radial force (6mm from front face)	N	80
Max. axial force (5)	N	10
Weight	g	275

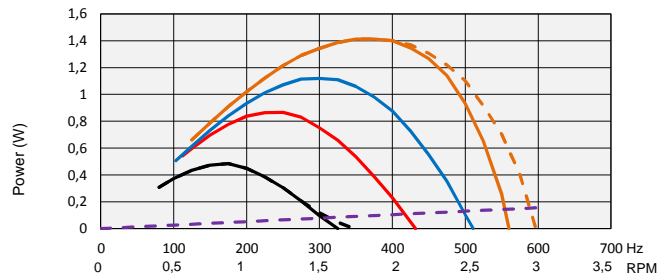
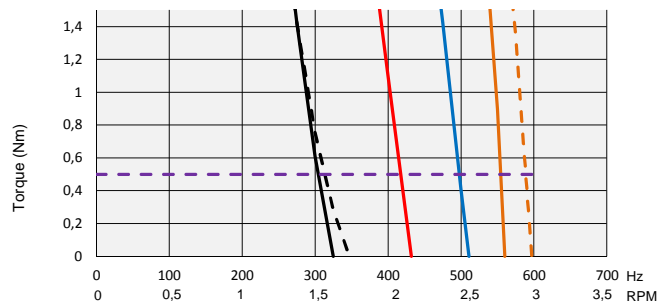

— A — B — C — D
 - - - A+ (over-speed) - - - D+ (over-speed)
 - - - Max. continuous gearbox torque

Specifications subject to change without notice. Updated 15/09/2016