

FEATURES

- 24-bit stereo audio ADC and DAC**
- 400 mW speaker amplifier (into 8 Ω load)**
- Programmable SigmaDSP audio processing core**
 - Wind noise detection and filtering
 - Enhanced stereo capture (ESC)
 - Dynamics processing
 - Equalization and filtering
 - Volume control and mute
- Sampling rates from 8 kHz to 96 kHz**
- Stereo pseudo differential microphone input**
- Optional stereo digital microphone input pulse-density modulation (PDM)**
- Stereo line output**
- PLL supporting a range of input clock rates**
- Analog and digital I/O 1.8 V to 3.3 V**
- Software control via SigmaStudio graphical user interface**
- Software-controllable, clickless mute**
- Software register and hardware pin standby mode**
- 32-lead, 5 mm × 5 mm LFCSP**

APPLICATIONS

- Digital still cameras
- Digital video cameras

GENERAL DESCRIPTION

The ADAU1781 is a low power, 24-bit stereo audio codec. The low noise DAC and ADC support sample rates from 8 kHz to 96 kHz. Low current draw and power saving modes make the ADAU1781 ideal for battery-powered audio applications.

A programmable SigmaDSP® core provides enhanced record and playback processing to improve overall audio quality.

The record path includes two digital stereo microphone inputs and an analog stereo input path. The analog inputs can be configured for either a pseudo differential or a single-ended stereo source. A dedicated analog beep input signal can be mixed into any output path. The ADAU1781 includes a stereo line output and speaker driver, which makes the device capable of supporting dynamic speakers.

The serial control bus supports the I²C® or SPI protocols, and the serial audio bus is programmable for I²S, left-justified, right-justified, or TDM mode. A programmable PLL supports flexible clock generation for all standard rates and available master clocks from 11 MHz to 20 MHz.

FUNCTIONAL BLOCK DIAGRAM

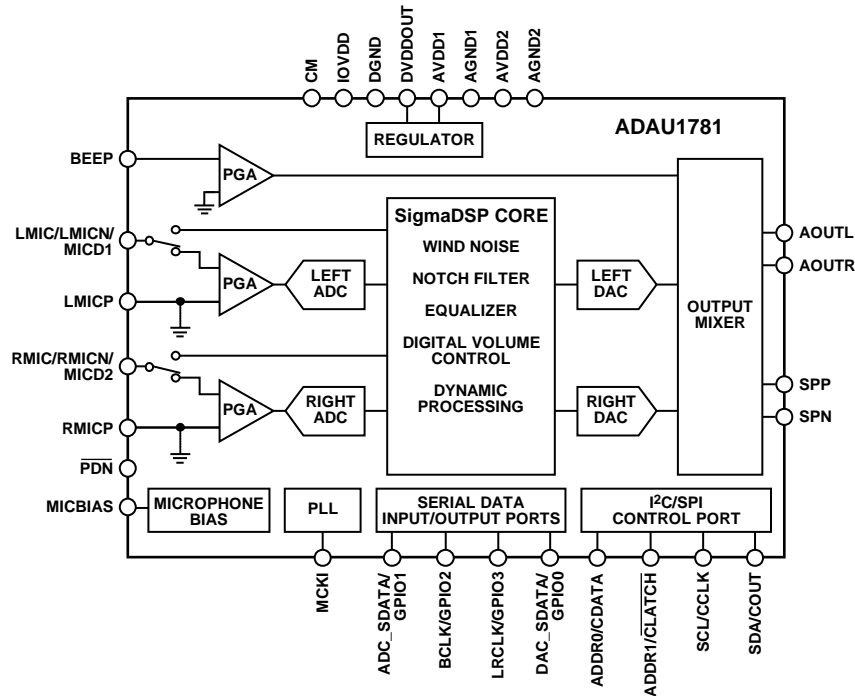

Figure 1.

Rev. B

Information furnished by Analog Devices is believed to be accurate and reliable. However, no responsibility is assumed by Analog Devices for its use, nor for any infringements of patents or other rights of third parties that may result from its use. Specifications subject to change without notice. No license is granted by implication or otherwise under any patent or patent rights of Analog Devices. Trademarks and registered trademarks are the property of their respective owners.

ADAU1781* Product Page Quick Links

Last Content Update: 11/01/2016

[Comparable Parts](#)

View a parametric search of comparable parts

[Evaluation Kits](#)

- ADAU1781 Evaluation Board
- ADUSB2EBZ Evaluation Board

[Documentation](#)

Application Notes

- AN-1006: Using the EVAL-ADUSB2EBZ
- AN-951: Using Hardware Controls with SigmaDSP GPIO Pins

Data Sheet

- ADAU1781: Low Noise Stereo Codec with SigmaDSP Processing Core

User Guides

- UG-177: Evaluating the ADAU1781 SigmaDSP using the EVAL-ADAU1781Z

[Software and Systems Requirements](#)

- ADAU1781 Sound CODEC Linux Driver
- Firmware Loader for SigmaDSPs

[Tools and Simulations](#)

- SigmaDSP Processors: Software and Tools

[Design Resources](#)

- ADAU1781 Material Declaration
- PCN-PDN Information
- Quality And Reliability
- Symbols and Footprints

[Discussions](#)

View all ADAU1781 EngineerZone Discussions

[Sample and Buy](#)

Visit the product page to see pricing options

[Technical Support](#)

Submit a technical question or find your regional support number

* This page was dynamically generated by Analog Devices, Inc. and inserted into this data sheet. Note: Dynamic changes to the content on this page does not constitute a change to the revision number of the product data sheet. This content may be frequently modified.

TABLE OF CONTENTS

Features	1	Input Signal Path	30
Applications.....	1	Analog-to-Digital Converters.....	31
General Description	1	Playback Signal Path	32
Functional Block Diagram	1	Output Signal Paths	32
Revision History	3	Digital-to-Analog Converters.....	32
Specifications.....	4	Line Outputs	32
Record Side Performance Specifications.....	4	Speaker Output.....	32
Output Side Performance Specifications.....	6	Control Ports.....	33
Power Supply Specifications.....	8	I ² C Port	33
Typical Power Management Measurements	9	SPI Port	36
Digital Filters.....	9	Memory and Register Access.....	36
Digital Input/Output Specifications.....	10	Serial Data Input/Output Ports	38
Digital Timing Specifications	11	TDM Modes.....	38
Absolute Maximum Ratings.....	14	General-Purpose Input/Outputs	40
Thermal Resistance	14	DSP Core	41
ESD Caution.....	14	Signal Processing.....	41
Pin Configuration and Function Descriptions.....	15	Architecture	41
Typical Performance Characteristics	17	Program Counter	41
System Block Diagrams	20	Features	41
Theory of Operation	24	Numeric Formats	42
Startup, Initialization, and Power	25	Programming.....	42
Power-Up Sequence	25	Program RAM, Parameter RAM, and Data RAM.....	44
Clock Generation and Management.....	26	Program RAM	44
Enabling Digital Power to Functional Subsystems	26	Parameter RAM.....	44
Setting Up the SigmaDSP Core	26	Data RAM	44
Power Reduction Modes.....	26	Read/Write Data Formats	44
Power-Down Sequence.....	26	Software Safeload	45
Clocking and Sampling Rates	27	Software Slew	46
Core Clock.....	27	Applications Information	47
Sampling Rates.....	27	Power Supply Bypass Capacitors.....	47
PLL.....	28	GSM Noise Filter	47
Record Signal Path.....	30	Grounding.....	47

Speaker Driver Supply Trace (AVDD2)	47	Audio Converter Configuration	63
Exposed Pad PCB Design	47	Playback Path Configuration	68
Control Register Map	48	Pad Configuration	75
Clock Management, Internal Regulator, and PLL Control....	49	Digital Subsystem Configuration	82
Record Path Configuration.....	53	Outline Dimensions.....	89
Serial Port Configuration.....	58	Ordering Guide	89

REVISION HISTORY

1/11—Rev. A to Rev. B

Changes to Table 10	15
Changes to Power-Down PIN (PDN) Section	26
Changes to Table 23	36

3/10—Rev. 0 to Rev. A

Changes to Output Side Performance Specifications Section	
Condition Statement.....	6
Added Endnote 1 to Table 3.....	8
Changes to Figure 23	21
Changes to Figure 24	22
Changes to Figure 25	23
Changes to Table 33	48
Added Register 16434 (0x4032), Dejitter Control Section	81
Changes to Ordering Guide.....	89

12/09—Revision 0: Initial Version

SPECIFICATIONS

Performance of all channels is identical, exclusive of the interchannel gain mismatch and interchannel phase deviation specifications. Supply voltages AVDD = AVDD1 = AVDD2 = I/O supply = 3.3 V, digital supply = 1.5 V, unless otherwise noted; temperature = 25°C; master clock (MCLK) = 12.288 MHz ($f_s = 48$ kHz, $256 \times f_s$ mode); input sample rate = 48 kHz; measurement bandwidth = 20 Hz to 20 kHz; word width = 24 bits; load capacitance (digital output) = 20 pF; load current (digital output) = 2 mA; high level input voltage = $0.7 \times \text{IOVDD}$; and low level input voltage = $0.3 \times \text{IOVDD}$. All power management registers are set to their default states.

RECORD SIDE PERFORMANCE SPECIFICATIONS

Specifications guaranteed at 25°C (ambient).

Table 1.

Parameter	Test Conditions/Comments	Min	Typ	Max	Unit	
ANALOG-TO-DIGITAL CONVERTERS						
ADC Resolution	All ADCs		24		Bits	
Digital Attenuation Step			0.375		dB	
Digital Attenuation Range			95		dB	
INPUT RESISTANCE						
Noninverting Inputs PGA (LMICP, RMICP)	All gain settings		500		k Ω	
Inverting Inputs PGA (LMICN, RMICN)	0 dB gain		62		k Ω	
	6 dB gain		32		k Ω	
	10 dB gain		22		k Ω	
	14 dB gain		14		k Ω	
	17 dB gain		10		k Ω	
	20 dB gain		8		k Ω	
	26 dB gain		5		k Ω	
	32 dB gain		4		k Ω	
Beep Input PGA	0 dB		20		k Ω	
	6 dB		9		k Ω	
	10 dB		6		k Ω	
	14 dB		3.5		k Ω	
	-23 dB		50		k Ω	
	20 dB		2		k Ω	
	26 dB		2		k Ω	
	32 dB		2		k Ω	
SINGLE-ENDED MICROPHONE INPUT TO ADC PATH						
Full-Scale Input Voltage (0 dB)	Scales linearly with AVDD		AVDD/3.3		V rms	
	AVDD = 1.8 V		0.55 (1.56)		V rms (V p-p)	
	AVDD = 3.3 V		1.0 (2.83)		V rms (V p-p)	
Dynamic Range	-60 dB input	94	AVDD = 1.8 V	96	dB	
			AVDD = 3.3 V	99.2	dB	
No Filter (RMS)	AVDD = 1.8 V	92	AVDD = 1.8 V	92	dB	
			AVDD = 3.3 V	96.5	dB	
Total Harmonic Distortion + Noise	-3 dBFS	92	AVDD = 1.8 V	-88	dB	
			AVDD = 3.3 V	-90	dB	
Signal-to-Noise Ratio	With A-Weighted Filter (RMS)	94	AVDD = 1.8 V	96	dB	
			AVDD = 3.3 V	100	dB	
	No Filter (RMS)	AVDD = 1.8 V	92	AVDD = 1.8 V	92	dB
				AVDD = 3.3 V	97	dB

Parameter	Test Conditions/Comments	Min	Typ	Max	Unit
Left/Right Microphone PGA Gain Range	AVDD = 3.3 V	0		32	dB
Left/Right Microphone PGA Mute Attenuation	AVDD = 3.3 V; mute set by Register 0x400E, Bit 1, and Register 0x400F, Bit 1		-98		dB
Interchannel Gain Mismatch	AVDD = 3.3 V		50		mdB
Offset Error	AVDD = 3.3 V		0.25		mV
Gain Error	AVDD = 3.3 V		-1		%
Interchannel Isolation	AVDD = 3.3 V		-98		dB
Power Supply Rejection Ratio	CM capacitor = 10 μ F AVDD = 3.3 V, 100 mV p-p at 217 Hz AVDD = 3.3 V, 100 mV p-p at 1 kHz		-55 -55		dB dB
DIFFERENTIAL MICROPHONE INPUT TO ADC PATH					
Full-Scale Input Voltage (0 dB)	Scales linearly with AVDD AVDD = 1.8 V AVDD = 3.3 V		AVDD/3.3 0.55 (1.56) 1.0 (2.83)		V rms V rms (V p-p) V rms (V p-p)
Dynamic Range	-60 dB input				
With A-Weighted Filter (RMS)	AVDD = 1.8 V AVDD = 3.3 V	94	96 99.2		dB dB
No Filter (RMS)	AVDD = 1.8 V AVDD = 3.3 V	92	92 96.5		dB dB
Total Harmonic Distortion + Noise	-3 dBFS AVDD = 1.8 V AVDD = 3.3 V			-84 -85	dB dB
Signal-to-Noise Ratio					
With A-Weighted Filter (RMS)	AVDD = 1.8 V AVDD = 3.3 V		96 100		dB dB
No Filter (RMS)	AVDD = 1.8 V AVDD = 3.3 V		92 97		dB dB
Left/Right Microphone PGA Mute Attenuation	AVDD = 3.3 V; mute set by Register 0x400E, Bit 1, and Register 0x400F, Bit 1		-98		dB
Interchannel Gain Mismatch	AVDD = 3.3 V		50		mdB
Offset Error	AVDD = 3.3 V		0.25		mV
Gain Error	AVDD = 3.3 V		-1		%
Interchannel Isolation	AVDD = 3.3 V		-85		dB
Common-Mode Rejection Ratio	AVDD = 3.3 V, 100 mV rms, 1 kHz AVDD = 3.3 V, 100 mV rms, 20 kHz		-60 -45		dB dB
BEEP TO LINE OUTPUT PATH					
Full-Scale Input Voltage (0 dB)	Scales linearly with AVDD AVDD = 1.8 V AVDD = 3.3 V		AVDD/3.3 0.55 (1.56) 1.0 (2.83)		V rms V rms (V p-p) V rms (V p-p)
Total Harmonic Distortion + Noise	-3 dBFS input, measured at AOUTL pin, beep gain set to 0 dB AVDD = 1.8 V AVDD = 3.3 V			-88 -88	dB dB
Signal-to-Noise Ratio					
With A-Weighted Filter (RMS)	AVDD = 1.8 V AVDD = 3.3 V		99 105		dB dB
No Filter (RMS)	AVDD = 1.8 V AVDD = 3.3 V		96 102		dB dB

ADAU1781

Parameter	Test Conditions/Comments	Min	Typ	Max	Unit
Dynamic Range With A-Weighted Filter (RMS)	–60 dB input				
	AVDD = 1.8 V		99		dB
No Filter (RMS)	AVDD = 3.3 V		105		dB
	AVDD = 1.8 V		96		dB
Beep Input Mute Attenuation	AVDD = 3.3 V		102		dB
	AVDD = 3.3 V; mute set by Register 0x4008, Bit 3		–90		dB
Offset Error	AVDD = 3.3 V		10		mV
Gain Error	AVDD = 3.3 V		–0.3		dB
Interchannel Gain Mismatch			30		mdB
Beep Input PGA Gain Range	AVDD = 3.3 V	–23		+32	dB
Beep Playback Mixer Gain Range	AVDD = 3.3 V	–15		+6	dB
Power Supply Rejection Ratio	CM capacitor = 10 μ F				
	AVDD = 3.3 V, 100 mV p-p at 217 Hz		–58		dB
	AVDD = 3.3 V, 100 mV p-p at 1 kHz		–72		dB
MICROPHONE BIAS	Microphone bias enabled				
Bias Voltage 0.65 \times AVDD	AVDD = 1.8 V, low bias		1.17		V
	AVDD = 3.3 V, low bias		2.145		V
0.90 \times AVDD	AVDD = 1.8 V, high bias		1.62		V
	AVDD = 3.3 V, high bias		2.97		V
Bias Current Source	AVDD = 3.3 V, high bias, high performance			5	mA
Noise in the Signal Bandwidth	AVDD = 3.3 V, 20 Hz to 20 kHz				
	High bias, high performance		39		nV \sqrt /Hz
	High bias, low performance		78		nV \sqrt /Hz
	Low bias, high performance		25		nV \sqrt /Hz
	Low bias, low performance		35		nV \sqrt /Hz
	AVDD = 1.8 V, 20 Hz to 20 kHz				
	High bias, high performance		35		nV \sqrt /Hz
	High bias, low performance		45		nV \sqrt /Hz
Low bias, high performance		23		nV \sqrt /Hz	
Low bias, low performance		23		nV \sqrt /Hz	

OUTPUT SIDE PERFORMANCE SPECIFICATIONS

Specifications guaranteed at 25°C (ambient). The output load for the speaker output path is an 8 Ω , 400 mW speaker.

Table 2.

Parameter	Test Conditions/Comments	Min	Typ	Max	Unit
DIGITAL-TO-ANALOG CONVERTERS					
DAC Resolution	All DACs		24		Bits
Digital Attenuation Step			0.375		dB
Digital Attenuation Range			95		dB
DAC TO LINE OUTPUT PATH					
Full-Scale Output Voltage (0 dB)	Scales linearly with AVDD		AVDD/3.3		V rms
	AVDD = 1.8 V		0.55 (1.56)		V rms (V p-p)
	AVDD = 3.3 V		1.0 (2.83)		V rms (V p-p)
Line Output Mute Attenuation, DAC to Mixer Path Muted	AVDD = 3.3 V; mute set by Register 0x401C, Bit 5, and Register 0x401E, Bit 6		–85		dB
Line Output Mute Attenuation, Line Output Muted	AVDD = 3.3 V; mute set by Register 0x4025, Bit 1, and Register 0x4026, Bit 1		–85		dB

Parameter	Test Conditions/Comments	Min	Typ	Max	Unit
Dynamic Range With A-Weighted Filter (RMS)	-60 dB input AVDD = 1.8 V		99		dB
	AVDD = 3.3 V	94	103		dB
No Filter (RMS)	AVDD = 1.8 V		97		dB
	AVDD = 3.3 V	92	100		dB
Total Harmonic Distortion + Noise	-3 dBFS				dB
	AVDD = 1.8 V		-88		dB
	AVDD = 3.3 V		-88		dB
Signal-to-Noise Ratio With A-Weighted Filter (RMS)	AVDD = 1.8 V		99		dB
	AVDD = 3.3 V		103		dB
No Filter (RMS)	AVDD = 1.8 V		97		dB
	AVDD = 3.3 V		100		dB
Power Supply Rejection Ratio	CM capacitor = 10 μ F				
	AVDD = 3.3 V, 100 mV p-p at 217 Hz		-55		dB
	AVDD = 3.3 V, 100 mV p-p at 1 kHz		-63		dB
Gain Error	AVDD = 3.3 V		-1		dB
Interchannel Gain Mismatch	AVDD = 3.3 V		50		mdB
Offset Error	AVDD = 3.3 V		10		mV
DAC TO SPEAKER OUTPUT PATH					
Differential Full-Scale Output Voltage (0 dB)	P_o = output power Scales linearly with AVDD		AVDD/1.65		V rms
	AVDD = 1.8 V		1.1 (3.12)		V rms (V p-p)
	AVDD = 3.3 V		2.0 (5.66)		V rms (V p-p)
Total Harmonic Distortion + Noise	4 Ω Load				
	AVDD = 1.8 V, P_o = 50 mW		-60		dB
	AVDD = 3.3 V, P_o = 175 mW		-60		dB
	8 Ω Load				
	AVDD = 1.8 V, P_o = 50 mW		-60		dB
	AVDD = 3.3 V, P_o = 175 mW		-60		dB
	AVDD = 3.3 V, P_o = 330 mW		-60		dB
	AVDD = 3.3 V, P_o = 440 mW		-16		dB
Dynamic Range With A-Weighted Filter (RMS)	-60 dB input AVDD = 1.8 V		100		dB
	AVDD = 3.3 V	94	105		dB
No Filter (RMS)	AVDD = 1.8 V		98		dB
	AVDD = 3.3 V	92	103		dB
Signal-to-Noise Ratio With A-Weighted Filter (RMS)	AVDD = 1.8 V		100		dB
	AVDD = 3.3 V		105		dB
No Filter (RMS)	AVDD = 1.8 V		98		dB
	AVDD = 3.3 V		103		dB
Power Supply Rejection Ratio	CM capacitor = 10 μ F				
	AVDD = 3.3 V, 100 mV p-p at 217 Hz		-55		dB
	AVDD = 3.3 V, 100 mV p-p at 1 kHz		-55		dB
Differential Offset Error	AVDD = 3.3 V		2		mV
Mono Mixer Mute Attenuation, DAC to Mixer Path Muted	Mute set by Register 0x401F, Bit 0		-90		dB
BEEP TO SPEAKER OUTPUT PATH					
Differential Full-Scale Output Voltage (0 dB)	P_o = output power Scales linearly with AVDD		AVDD/1.65		V rms
	AVDD = 1.8 V		1.1 (3.12)		V rms (V p-p)
	AVDD = 3.3 V		2.0 (5.66)		V rms (V p-p)

ADAU1781

Parameter	Test Conditions/Comments	Min	Typ	Max	Unit
Total Harmonic Distortion + Noise	8 Ω , 1 nF load, AVDD = 1.8 V, P _O = 50 mW		-60		dB
	AVDD = 3.3 V, P _O = 175 mW		-60		dB
Dynamic Range With A-Weighted Filter (RMS)	-60 dB input				
	AVDD = 1.8 V		97		dB
No Filter (RMS)	AVDD = 3.3 V		103		dB
	AVDD = 1.8 V		94		dB
Signal-to-Noise Ratio	AVDD = 3.3 V		100		dB
	AVDD = 1.8 V				
With A-Weighted Filter (RMS)	AVDD = 3.3 V		103		dB
	AVDD = 1.8 V		96		dB
No Filter (RMS)	AVDD = 3.3 V		101		dB
	AVDD = 1.8 V				
Power Supply Rejection Ratio	CM capacitor = 10 μ F				
	100 mV p-p at 217 Hz		-57		dB
	100 mV p-p at 1 kHz		-60		dB
Differential Offset Error			2		mV
Mono Mixer Mute Attenuation, Beep to Mixer Path Muted	Mute set by Register 0x401F, Bit 0		-90		dB
REFERENCE (CM PIN) Common-Mode Reference Output			AVDD/2		V

POWER SUPPLY SPECIFICATIONS

AVDD1 and AVDD2 must always be equal. Power supply measurements are taken with the SigmaDSP processing core enabled.

Table 3.

Parameter	Test Conditions/Comments	Min	Typ	Max	Unit
AVDD1, AVDD2		1.8 ¹	3.3	3.65	V
IOVDD		1.63	3.3	3.65	V
Digital I/O Current (IOVDD = 3.3 V) Slave Mode, Analog I/O, 12.288 MHz External MCLK Input	20 pF capacitive load on all digital pins f ₅ = 48 kHz		0.20		mA
	f ₅ = 96 kHz		0.35		mA
Master Mode, MCKO Disabled	f ₅ = 8 kHz		0.04		mA
	f ₅ = 48 kHz		1.25		mA
	f ₅ = 96 kHz		2.50		mA
Digital I/O Current (IOVDD = 1.8 V) Slave Mode, Analog I/O, 12.288 MHz External MCLK Input	f ₅ = 8 kHz		0.22		mA
	20 pF capacitive load on all digital pins f ₅ = 48 kHz		0.10		mA
Master Mode, MCKO Disabled	f ₅ = 96 kHz		0.18		mA
	f ₅ = 8 kHz		0.02		mA
	f ₅ = 48 kHz		0.68		mA
Analog Current (AVDD)	f ₅ = 96 kHz		1.33		mA
	f ₅ = 8 kHz		0.12		mA
	See Table 4				

¹ The zero-cross detection of the beep path is not supported at AVDD1, AVDD2 < 2.2 V.

TYPICAL POWER MANAGEMENT MEASUREMENTS

Master clock = 12.288 MHz, PLL is active in integer mode at a $256 \times f_s$ input rate for $f_s = 48$ kHz, analog and digital input tones are -1 dBFS with a frequency of 1 kHz. Analog input and output are simultaneously active. Pseudo differential stereo input is routed to ADCs, and DACs are routed to stereo line output with a 16 k Ω load. ADC input at -1 dBFS, DAC input at 0 dBFS. The speaker output is disabled. The serial port is configured in slave mode. The beep path is disabled. SigmaDSP processing is enabled. Current measurements are given in units of mA rms.

Table 4. Mixer Boost and Power Management Conditions

Operating Voltage	Power Management Mode ¹	Mixer Boost Mode ²	Typical AVDD Current Consumption (mA)	Typical ADC THD + N (dB)	Typical Line Output THD + N (dB)
AVDD = IOVDD = 3.3 V	Normal (default)	Normal operation	16.84	88.5	93.0
		Boost Level 1	16.88	88.5	93.0
		Boost Level 2	16.92	88.5	93.0
		Boost Level 3	17.00	88.5	93.0
	Extreme power saving	Normal operation	15.66	88.0	87.5
		Boost Level 1	15.68	88.0	87.5
		Boost Level 2	15.70	88.0	87.5
		Boost Level 3	15.75	88.0	87.5
	Enhanced performance	Normal operation	17.43	88.5	94.5
		Boost Level 1	17.50	88.5	94.5
		Boost Level 2	17.53	88.5	94.5
		Boost Level 3	17.63	88.5	94.5
	Power saving	Normal operation	16.25	89.0	90.5
		Boost Level 1	16.28	89.0	90.5
		Boost Level 2	16.31	89.0	90.5
		Boost Level 3	16.38	89.0	90.5
AVDD = IOVDD = 1.8 V	Normal (default)	Normal operation	15.15	88.5	89.5
		Boost Level 1	15.19	88.5	89.5
		Boost Level 2	15.23	88.5	89.5
		Boost Level 3	15.30	88.5	89.5
	Extreme power saving	Normal operation	14.03	86.5	85.5
		Boost Level 1	14.05	86.5	85.5
		Boost Level 2	14.07	86.5	85.5
		Boost Level 3	14.12	86.5	85.5
	Enhanced performance	Normal operation	15.71	88.5	90.5
		Boost Level 1	15.76	88.5	90.5
		Boost Level 2	15.81	88.5	90.5
		Boost Level 3	15.89	88.5	90.5
	Power saving	Normal operation	14.59	88.0	88.0
		Boost Level 1	14.62	88.0	88.0
		Boost Level 2	14.65	88.0	88.0
		Boost Level 3	14.71	88.0	88.0

¹ Set by Register 0x4009, Bits[4:1], and Register 0x4029, Bits[5:2].

² Set by Register 0x4009, Bits[6:5].

DIGITAL FILTERS

Table 5.

Parameter	Mode	Factor	Min	Typ	Max	Unit
ADC DECIMATION FILTER	All modes, typ value is for 48 kHz					
Pass Band		$0.4375 \times f_s$		21		kHz
Pass-Band Ripple				± 0.015		dB
Transition Band		$0.5 \times f_s$		24		kHz
Stop Band		$0.5625 \times f_s$		27		kHz
Stop-Band Attenuation				70		dB
Group Delay		$22.9844/f_s$		479		μ s

ADAU1781

Parameter	Mode	Factor	Min	Typ	Max	Unit
DAC INTERPOLATION FILTER						
Pass Band	48 kHz mode, typ value is for 48 kHz	$0.4535 \times f_s$		22		kHz
	96 kHz mode, typ value is for 96 kHz	$0.3646 \times f_s$	35	69		kHz
Pass-Band Ripple	48 kHz mode, typ value is for 48 kHz				± 0.01	dB
	96 kHz mode, typ value is for 96 kHz				± 0.05	dB
Transition Band	48 kHz mode, typ value is for 48 kHz	$0.5 \times f_s$		24		kHz
	96 kHz mode, typ value is for 96 kHz	$0.5 \times f_s$		48		kHz
Stop Band	48 kHz mode, typ value is for 48 kHz	$0.5465 \times f_s$		26		kHz
	96 kHz mode, typ value is for 96 kHz	$0.6354 \times f_s$		61		kHz
Stop-Band Attenuation	48 kHz mode, typ value is for 48 kHz		70			dB
	96 kHz mode, typ value is for 96 kHz		70			dB
Group Delay	48 kHz mode, typ value is for 48 kHz	$25/f_s$		521		μs
	96 kHz mode, typ value is for 96 kHz	$11/f_s$		115		μs

DIGITAL INPUT/OUTPUT SPECIFICATIONS

$-25^{\circ}\text{C} < T_A < +85^{\circ}\text{C}$, IOVDD = 1.62 V to 3.63 V, unless otherwise specified.

Table 6.

Parameter	Conditions/Comments	Min	Typ	Max	Unit
HIGH LEVEL INPUT VOLTAGE (V_{IH})		$0.7 \times \text{IOVDD}$			V
LOW LEVEL INPUT VOLTAGE (V_{IL})	IOVDD \geq 2.97 V			$0.3 \times \text{IOVDD}$	V
	$1.8 \text{ V} \leq \text{IOVDD} \leq 2.97 \text{ V}$			$0.2 \times \text{IOVDD}$	V
	IOVDD < 1.8 V			$0.1 \times \text{IOVDD}$	V
INPUT LEAKAGE	I_{IH} at $V_{IH} = 2.4 \text{ V}$		± 0.17		μA
	I_{IL} at $V_{IL} = 0.8 \text{ V}$		± 0.17		μA
	I_{IL} of MCKI		-7		μA
	I_{IH} with internal pull-up		± 0.7		μA
	I_{IL} with internal pull-down		-7		μA
	I_{IH} with internal pull-up I_{IL} with internal pull-down		5 ± 0.18		μA
HIGH LEVEL OUTPUT VOLTAGE (V_{OH})	For low drive strength, $I_{OH} = 2 \text{ mA}$ and $I_{OL} = 2 \text{ mA}$ at IOVDD = 3.3 V, $I_{OH} = 0.6 \text{ mA}$ and $I_{OL} = 0.6 \text{ mA}$ at IOVDD = 1.8 V; for high drive strength, $I_{OH} = 3 \text{ mA}$ and $I_{OL} = 3 \text{ mA}$ at IOVDD = 3.3 V, $I_{OH} = 0.9 \text{ mA}$ and $I_{OL} = 0.9 \text{ mA}$ at IOVDD = 1.8 V	IOVDD - 0.4			V
LOW LEVEL OUTPUT VOLTAGE (V_{OL})	For low drive strength, $I_{OH} = 2 \text{ mA}$ and $I_{OL} = 2 \text{ mA}$ at IOVDD = 3.3 V, $I_{OH} = 0.6 \text{ mA}$ and $I_{OL} = 0.6 \text{ mA}$ at IOVDD = 1.8 V; for high drive strength, $I_{OH} = 3 \text{ mA}$ and $I_{OL} = 3 \text{ mA}$ at IOVDD = 3.3 V, $I_{OH} = 0.9 \text{ mA}$ and $I_{OL} = 0.9 \text{ mA}$ at IOVDD = 1.8 V			0.4	V
INPUT CAPACITANCE				5	pF

DIGITAL TIMING SPECIFICATIONS

-25°C < T_A < +85°C, IOVDD = 1.62 V to 3.63 V, unless otherwise specified.

Table 7. Digital Timing

Parameter	Limit		Unit	Description
	t _{MIN}	t _{MAX}		
MASTER CLOCK				
t _{MP}	50	90.9	ns	Master clock (MCLK) period (that is, period of the signal input to MCKI).
Duty Cycle	30	70	%	
SERIAL PORT				
t _{BIL}	10		ns	BCLK pulse width low.
t _{BIH}	10		ns	BCLK pulse width high.
t _{LIS}	5		ns	LRCLK setup. Time to BCLK rising.
t _{LIH}	5		ns	LRCLK hold. Time from BCLK rising.
t _{SIS}	5		ns	DAC_SDATA setup. Time to BCLK rising.
t _{SIH}	5		ns	DAC_SDATA hold. Time from BCLK rising.
t _{SODM}		70	ns	ADC_SDATA delay. Time from BCLK falling in master mode.
SPI PORT				
f _{CCLK,R}		5	MHz	CCLK frequency, read operation, IOVDD = 1.8 V ± 10%.
f _{CCLK,R}		10	MHz	CCLK frequency, read operation, IOVDD = 3.3 V ± 10%.
f _{CCLK,W}		25	MHz	CCLK frequency, write operation, IOVDD = 1.8 V ± 10%.
f _{CCLK,W}		25	MHz	CCLK frequency, write operation, IOVDD = 3.3 V ± 10%.
t _{CCPL}	10		ns	CCLK pulse width low.
t _{CCPH}	10		ns	CCLK pulse width high.
t _{CLS}	10		ns	CLATCH setup. Time to CCLK rising.
t _{CLH}	5		ns	CLATCH hold. Time from CCLK rising.
t _{CLPH}	10		ns	CLATCH pulse width high.
t _{CDS}	5		ns	CDATA setup. Time to CCLK rising.
t _{CDH}	5		ns	CDATA hold. Time from CCLK rising.
t _{COD}		70		COU _T delay from CCLK edge to valid data, IOVDD = 1.8 V ± 10%.
		40	ns	COU _T delay from CCLK edge to valid data, IOVDD = 3.3 V ± 10%.
I ² C PORT				
f _{SCL}		400	kHz	SCL frequency.
t _{SCLH}	0.6		µs	SCL high.
t _{SCLL}	1.3		µs	SCL low.
t _{SCS}	0.6		µs	Setup time; relevant for repeated start condition.
t _{SCH}	0.6		µs	Hold time. After this period, the first clock is generated.
t _{DS}	100		ns	Data setup time.
t _{SCR}		300	ns	SCL rise time.
t _{SCF}		300	ns	SCL fall time.
t _{SDR}		300	ns	SDA rise time.
t _{SDF}		300	ns	SDA fall time.
t _{BFT}	0.6		µs	Bus-free time. Time between stop and start.
DIGITAL MICROPHONE				R _L = 1 MΩ, C _L = 14 pF.
t _{DCF}		10	ns	Digital microphone clock fall time.
t _{DCR}		10	ns	Digital microphone clock rise time.
t _{DDV}	22	30	ns	Digital microphone delay time for valid data.
t _{DDH}	0	12	ns	Digital microphone delay time for data three-stated.

Digital Timing Diagrams

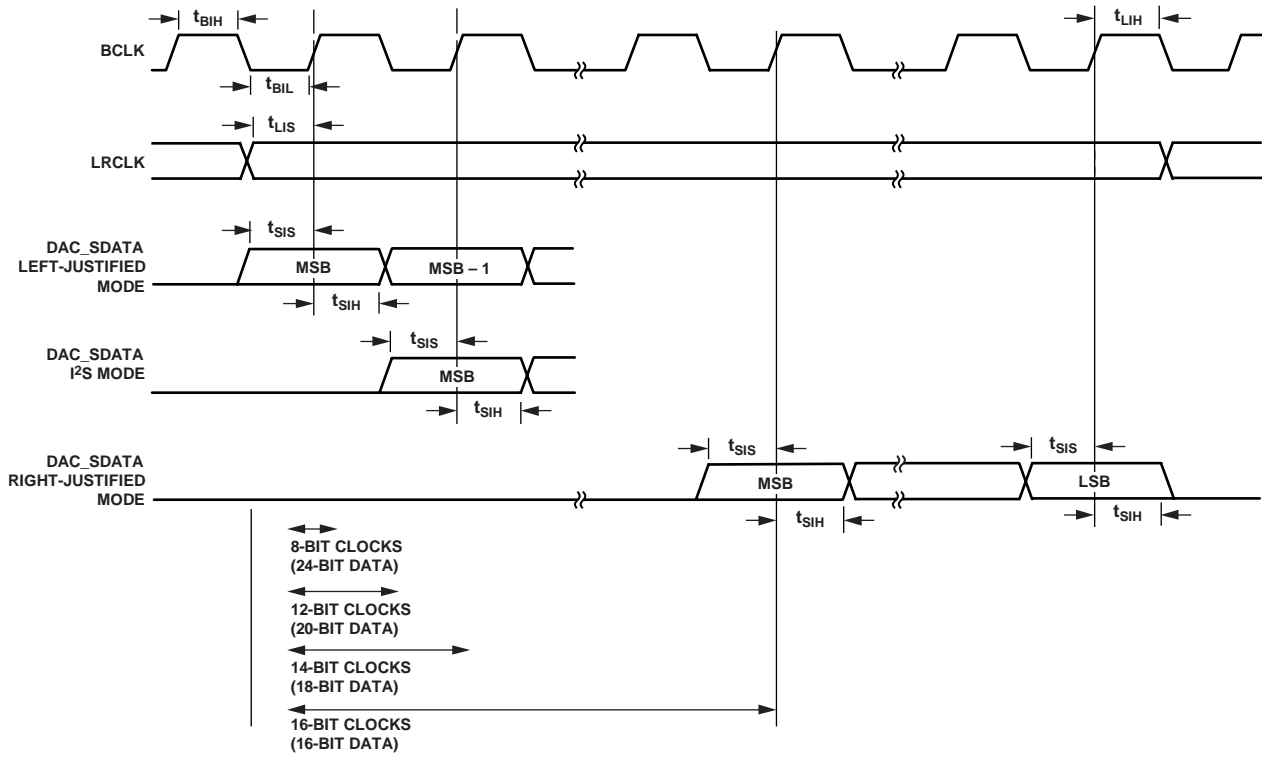

Figure 2. Serial Input Port Timing

08314-002

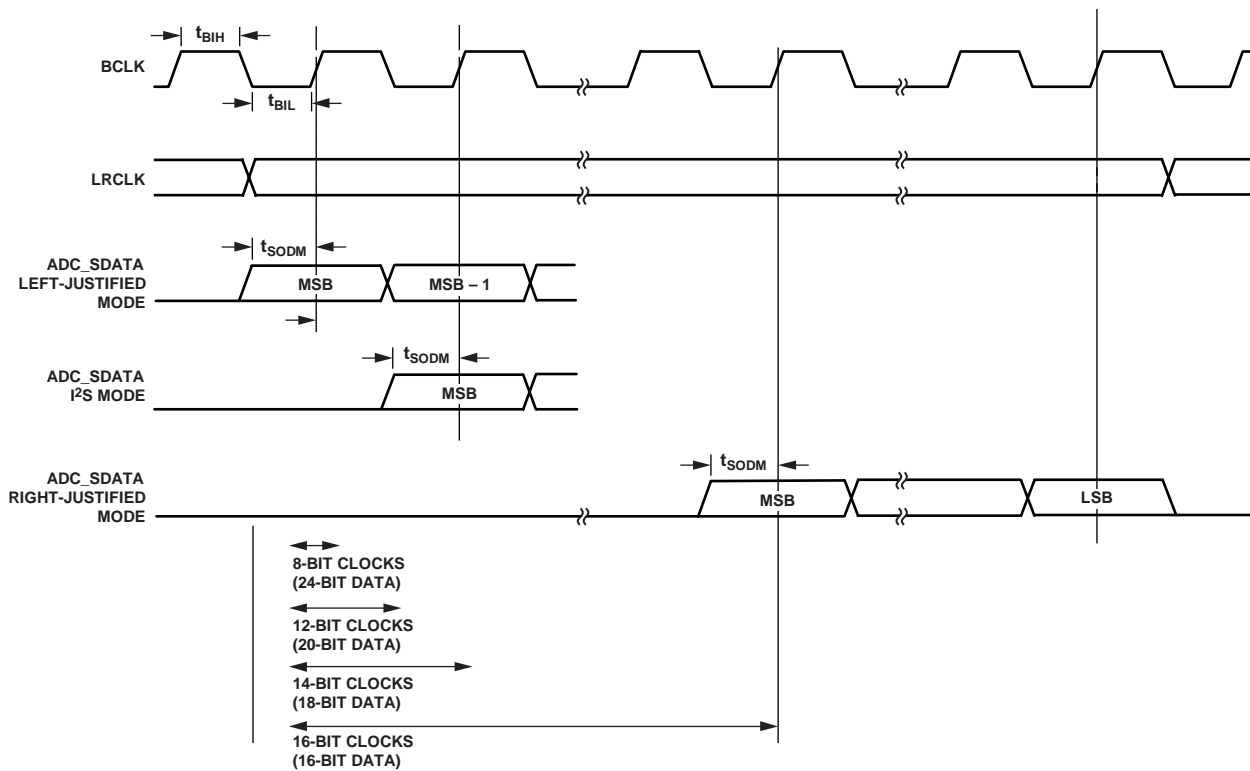

Figure 3. Serial Output Port Timing

08314-003

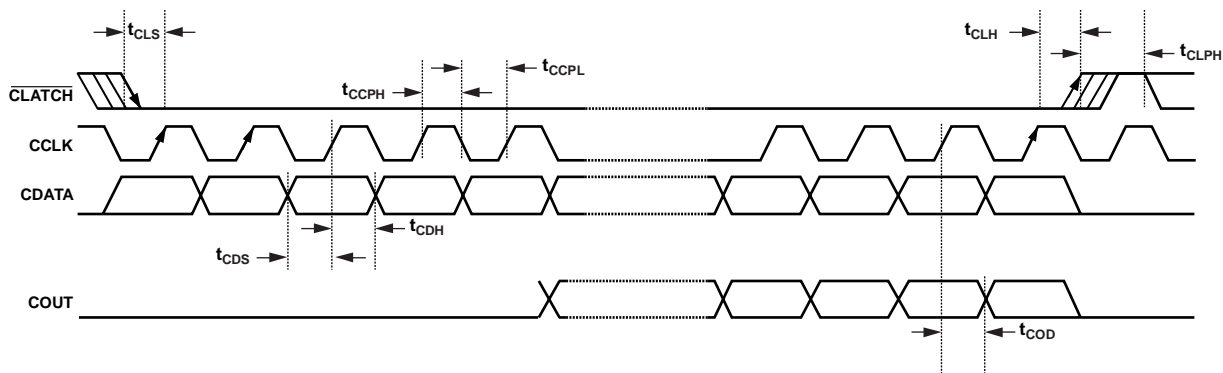

Figure 4. SPI Port Timing

08314-004

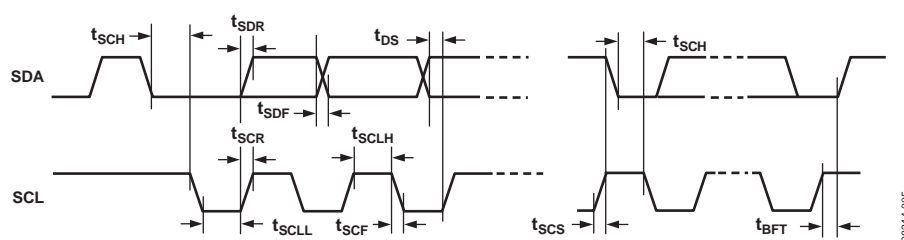

Figure 5. I²C Port Timing

08314-005

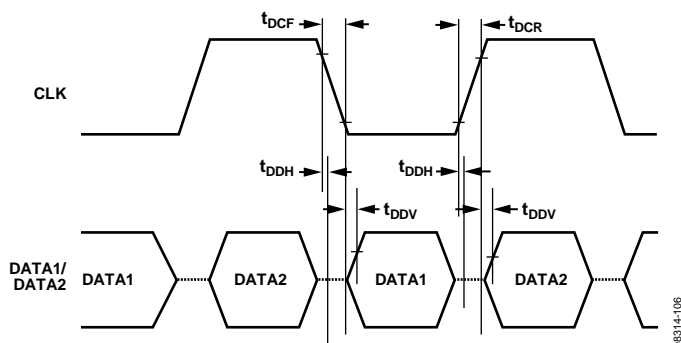

Figure 6. Digital Microphone Timing

08314-106

ABSOLUTE MAXIMUM RATINGS

Table 8.

Parameter	Rating
Power Supply (AVDD1 = AVDD2)	-0.3 V to +3.9 V
Input Current (Except Supply Pins)	±20 mA
Analog Input Voltage (Signal Pins)	-0.3 V to VDD + 0.3 V
Digital Input Voltage (Signal Pins)	-0.3 V to VDD + 0.3 V
Operating Temperature Range (Case)	-25°C to +85°C
Storage Temperature Range	-65°C to +150°C

Stresses above those listed under Absolute Maximum Ratings may cause permanent damage to the device. This is a stress rating only; functional operation of the device at these or any other conditions above those indicated in the operational section of this specification is not implied. Exposure to absolute maximum rating conditions for extended periods may affect device reliability.

THERMAL RESISTANCE

In Table 9, θ_{JA} is the junction-to-ambient thermal resistance, θ_{JB} is the junction-to-board thermal resistance, θ_{JC} is the junction-to-case thermal resistance, ψ_{JB} is the in-use junction-to-top of package thermal resistance, and ψ_{JT} is the in-use junction-to-board thermal resistance. All characteristics are for a 4-layer board.

Table 9. Thermal Resistance

Package Type	θ_{JA}	θ_{JB}	θ_{JC}	ψ_{JB}	ψ_{JT}	Unit
32-Lead LFCSP	35	19	2.5	18	0.3	°C/W

ESD CAUTION



ESD (electrostatic discharge) sensitive device. Charged devices and circuit boards can discharge without detection. Although this product features patented or proprietary protection circuitry, damage may occur on devices subjected to high energy ESD. Therefore, proper ESD precautions should be taken to avoid performance degradation or loss of functionality.

PIN CONFIGURATION AND FUNCTION DESCRIPTIONS

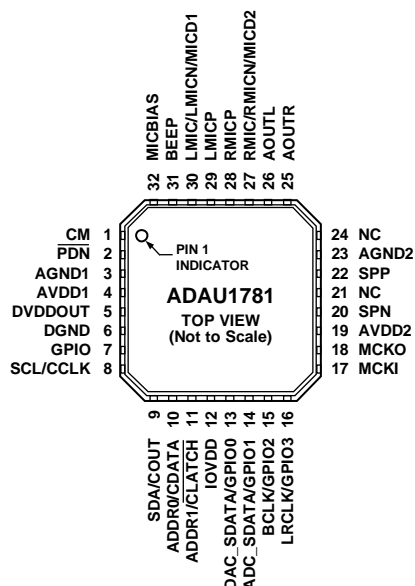

- NOTES**
1. NC = NO CONNECT.
 2. THE EXPOSED PAD IS CONNECTED INTERNALLY TO THE ADAU1781 GROUNDS. FOR INCREASED RELIABILITY OF THE SOLDER JOINTS AND MAXIMUM THERMAL CAPABILITY, IT IS RECOMMENDED THAT THE PAD BE SOLDERED TO THE GROUND PLANE.

06314-007

Figure 7. 32-Lead LFCSP Pin Configuration

Table 10. Pin Function Descriptions

Pin No.	Mnemonic	Type ¹	Description
1	CM	A_OUT	VDD/2V Common-Mode Reference. A 10 μ F to 47 μ F decoupling capacitor should be connected between this pin and ground to reduce crosstalk between the ADCs and DACs. The material of the capacitors is not critical. This pin can be used to bias external analog circuits, as long as they are not drawing current from CM (for example, the noninverting input of an op amp).
2	$\overline{\text{PDN}}$	A_IN	Power-Down. Connecting this pin to GND powers down the chip. Resides in AVDD1 domain.
3	AGND1	PWR	Analog Ground.
4	AVDD1	PWR	Analog Power Supply. Should be equivalent to AVDD2.
5	DVDDOUT	PWR	Digital Core Supply Decoupling Point. The digital supply is generated from an on-board regulator and does not require an external supply. DVDDOUT should be decoupled to DGND with a 100 nF capacitor.
6	DGND	PWR	Digital Ground.
7	GPIO	D_IO	Dedicated General-Purpose Input/Output.
8	SCL/CCLK	D_IN	I ² C Clock/SPI Clock.
9	SDA/COUT	D_IO	I ² C Data/SPI Data Output.
10	ADDR0/CDATA	D_IN	I ² C Address 0/SPI Data Input.
11	ADDR1/ $\overline{\text{CLATCH}}$	D_IN	I ² C Address 1/SPI Latch Signal.
12	IOVDD	PWR	Supply for Digital Input and Output Pins. The digital output pins are supplied from IOVDD, which sets the highest allowed input voltage for the digital input pins. The current draw of this pin is variable because it is dependent on the loads of the digital outputs. IOVDD should be decoupled to DGND with a 100 nF capacitor.
13	DAC_SDATA/GPIO0	D_IO	DAC Serial Input Data/General-Purpose Input and Output.
14	ADC_SDATA/GPIO1	D_IO	ADC Serial Output Data/General-Purpose Input and Output.
15	BCLK/GPIO2	D_IO	Serial Data Port Bit Clock/General-Purpose Input and Output.
16	LRCLK/GPIO3	D_IO	Serial Data Port Frame Clock/General-Purpose Input and Output.
17	MCKI	D_IN	Master Clock Input.

ADAU1781

Pin No.	Mnemonic	Type ¹	Description
18	MCKO	D_OUT	Master Clock Output.
19	AVDD2	PWR	Analog Power Supply. Should be equivalent to AVDD1.
20	SPN	A_OUT	Speaker Amplifier Negative Signal Output.
21	NC		No Connect.
22	SPP	A_OUT	Speaker Amplifier Positive Signal Output.
23	AGND2	PWR	Speaker Amplifier Ground.
24	NC		No Connect.
25	AOUTR	A_OUT	Line Output Amplifier, Right Channel.
26	AOUTL	A_OUT	Line Output Amplifier, Left Channel.
27	RMIC/RMICN/MICD2	A_IN	Right Channel Input from Single-Ended Source/Right Channel Input from Negative Pseudo Differential Source/Digital Microphone Input 2.
28	RMICP	A_IN	Right Channel Input from Positive Pseudo Differential Source.
29	LMICP	A_IN	Left Channel Input from Positive Pseudo Differential Source.
30	LMIC/LMICN/MICD1	A_IN	Left Channel Input from Single-Ended Source/Left Channel Input from Negative Pseudo Differential Source/Digital Microphone Input 1.
31	BEEP	A_IN	Beep Signal Input.
32	MICBIAS	PWR	Microphone Bias.
	THERM_PAD (Exposed Pad)		Exposed Pad. The exposed pad is connected internally to the ADAU1781 grounds. For increased reliability of the solder joints and maximum thermal capability, it is recommended that the pad be soldered to the ground plane.

¹ A_OUT = analog output, A_IN = analog input, PWR = power, D_IO = digital input/output, D_OUT = digital output, and D_IN = digital input.

TYPICAL PERFORMANCE CHARACTERISTICS

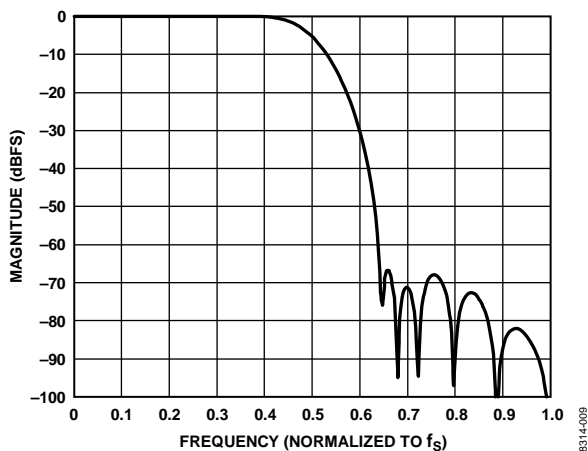

Figure 8. ADC Decimation Filter, 64x Oversampling, Normalized to f_s

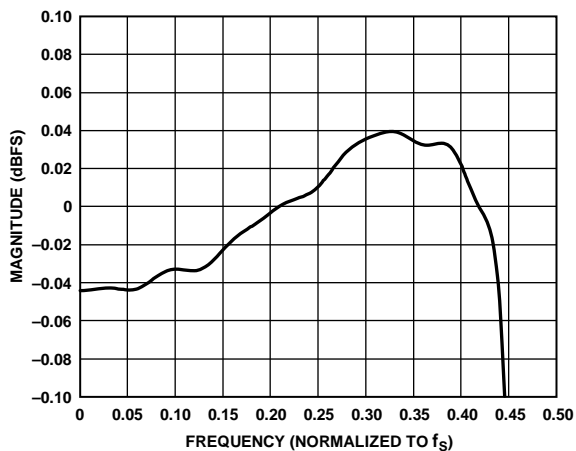

Figure 11. ADC Decimation Filter Pass-Band Ripple, 128x Oversampling, Normalized to f_s

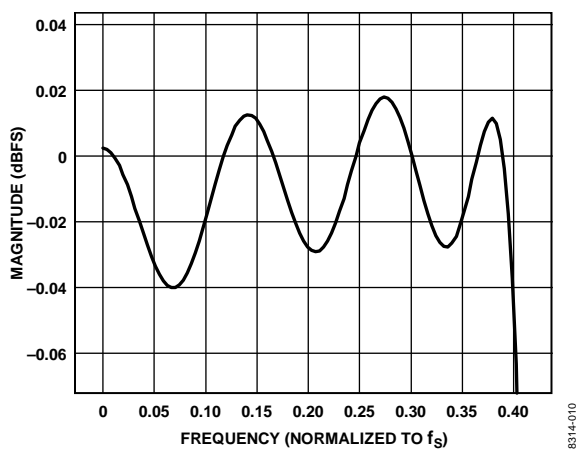

Figure 9. ADC Decimation Filter Pass-Band Ripple, 64x Oversampling, Normalized to f_s

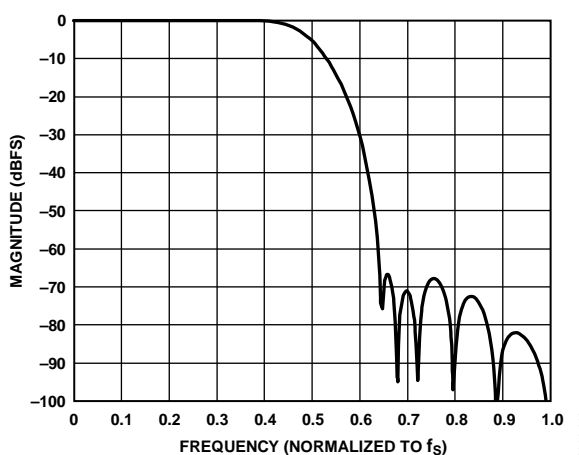

Figure 12. ADC Decimation Filter, Double-Rate Mode, Normalized to f_s

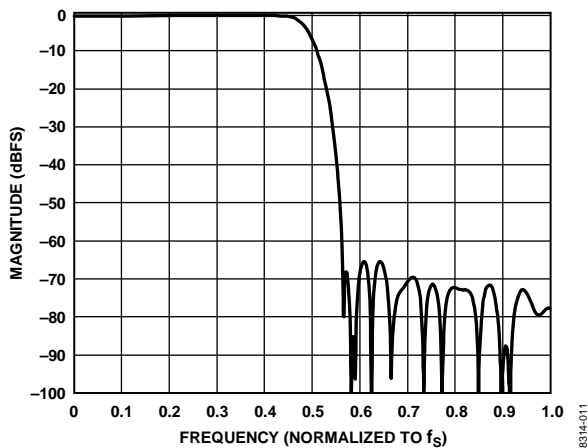

Figure 10. ADC Decimation Filter, 128x Oversampling, Normalized to f_s

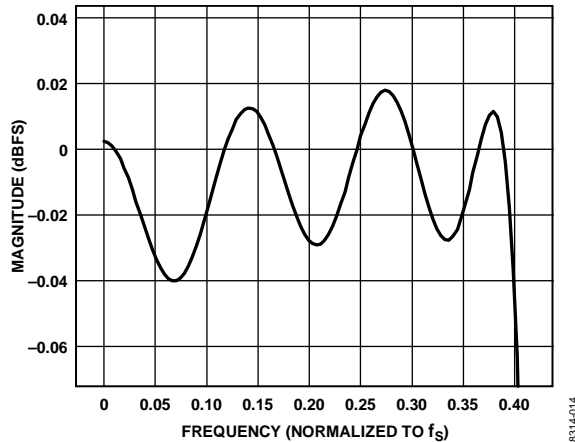

Figure 13. ADC Decimation Filter Pass-Band Ripple, Double-Rate Mode, Normalized to f_s

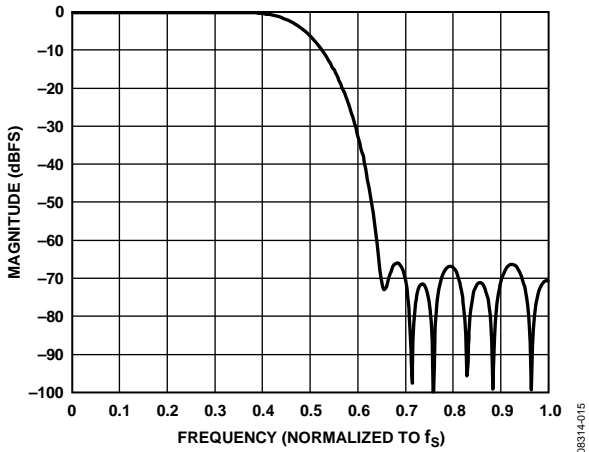

Figure 14. DAC Interpolation Filter, 64x Oversampling, Normalized to f_s

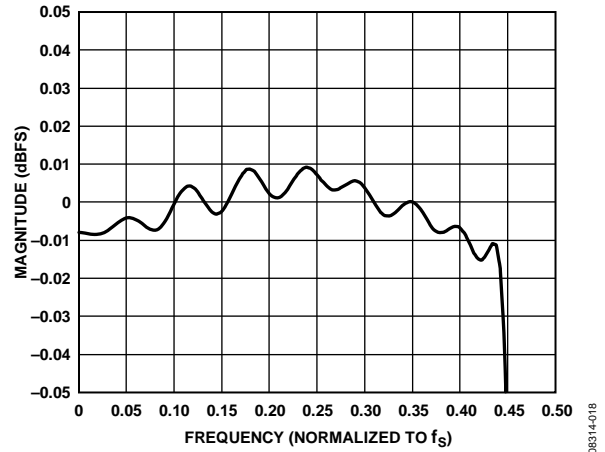

Figure 17. DAC Interpolation Filter Pass-Band Ripple, 128x Oversampling, Normalized to f_s

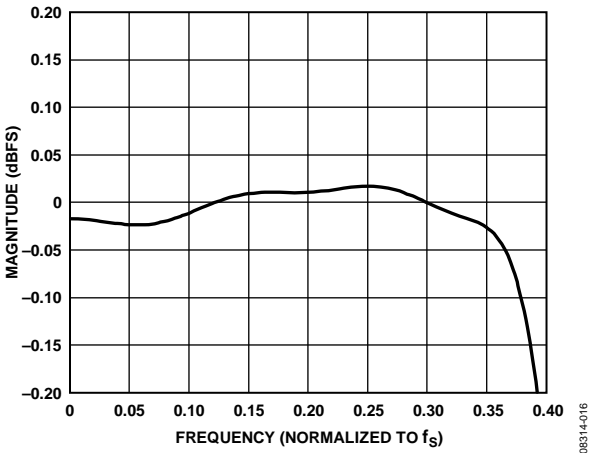

Figure 15. DAC Interpolation Filter Pass-Band Ripple, 64x Oversampling, Normalized to f_s

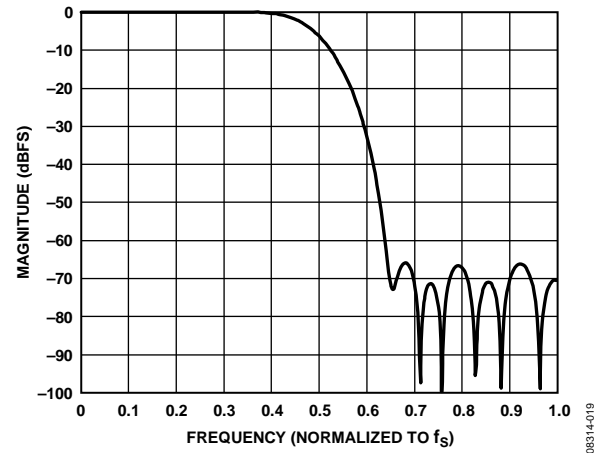

Figure 18. DAC Interpolation Filter, Double-Rate Mode, Normalized to f_s

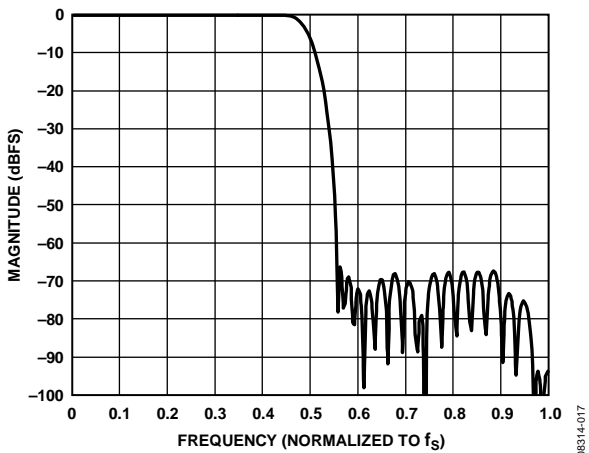

Figure 16. DAC Interpolation Filter, 128x Oversampling, Normalized to f_s

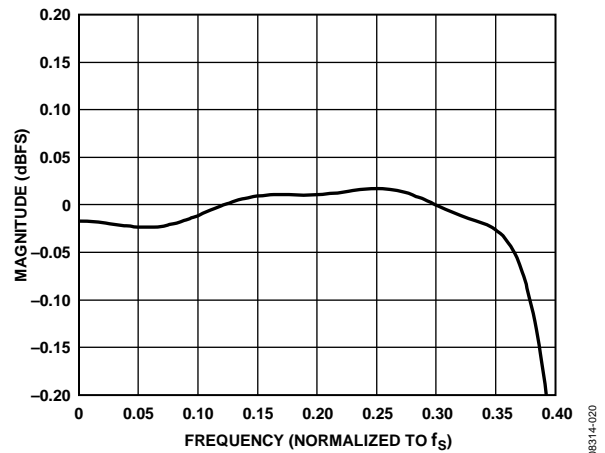

Figure 19. DAC Interpolation Filter Pass-Band Ripple, Double-Rate Mode, Normalized to f_s

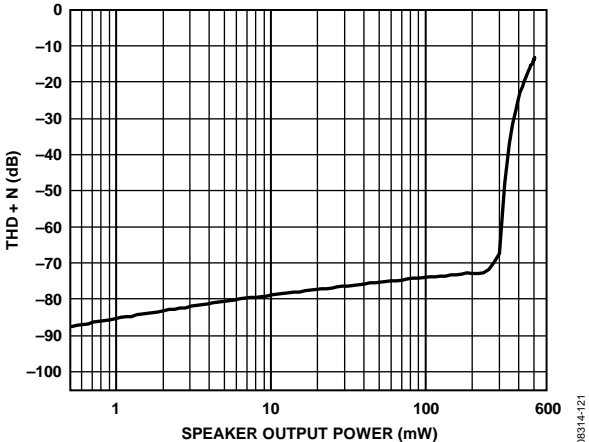

Figure 20. THD + N vs. Speaker Output Power, 8 Ω Load, 3.3 V Supply

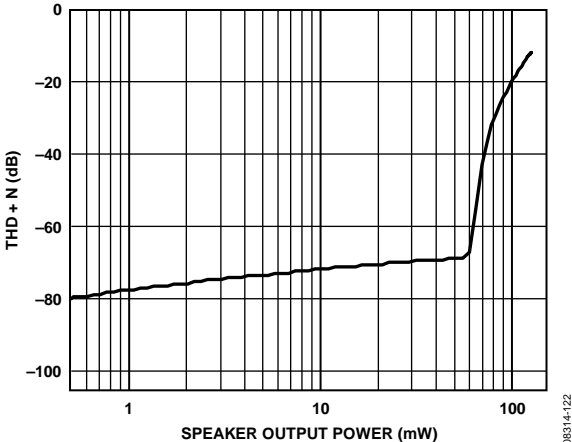

Figure 21. THD + N vs. Speaker Output Power, 8 Ω Load, 1.8 V Supply

SYSTEM BLOCK DIAGRAMS

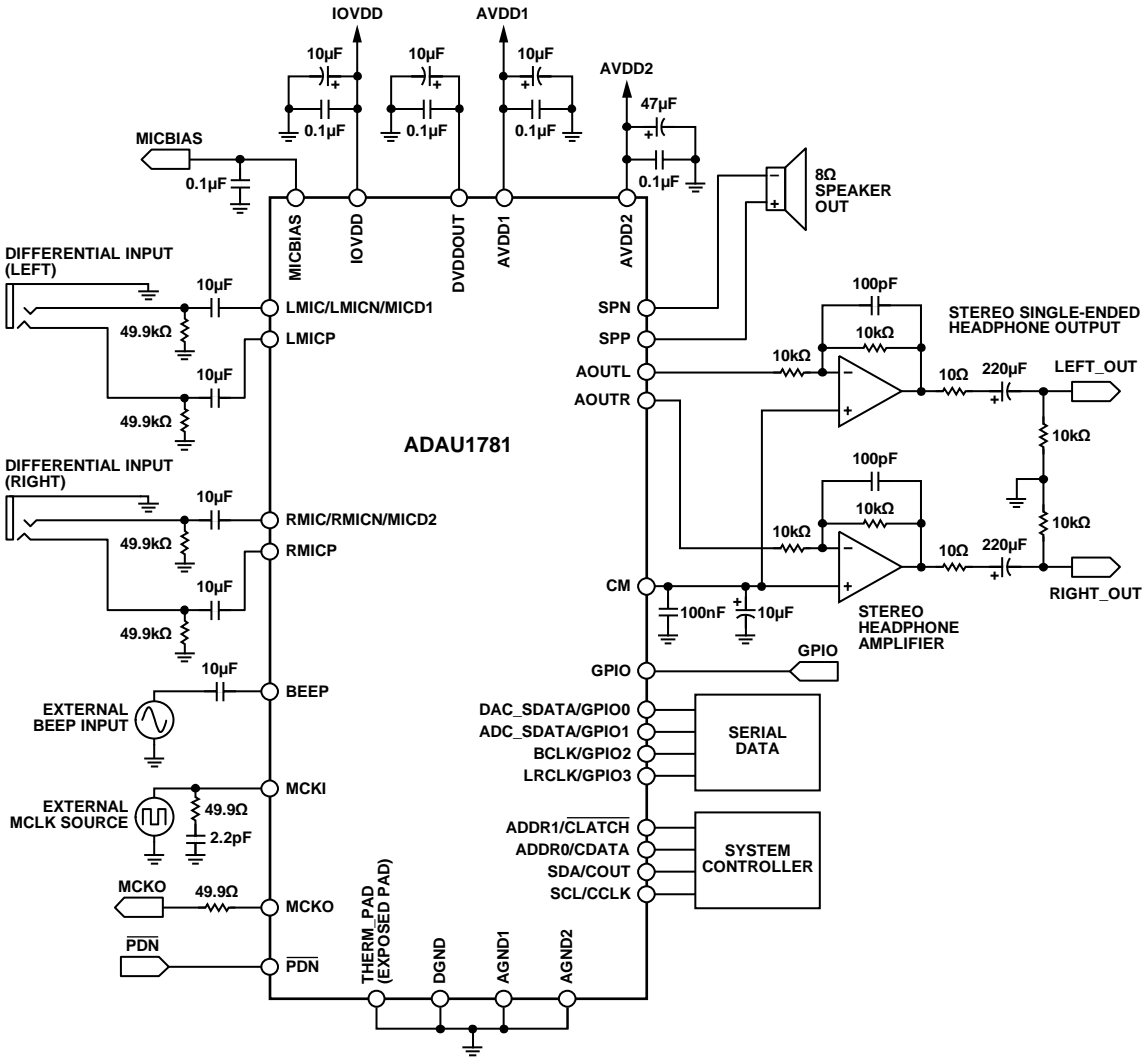

Figure 22. System Block Diagram with Differential Inputs

08314-021

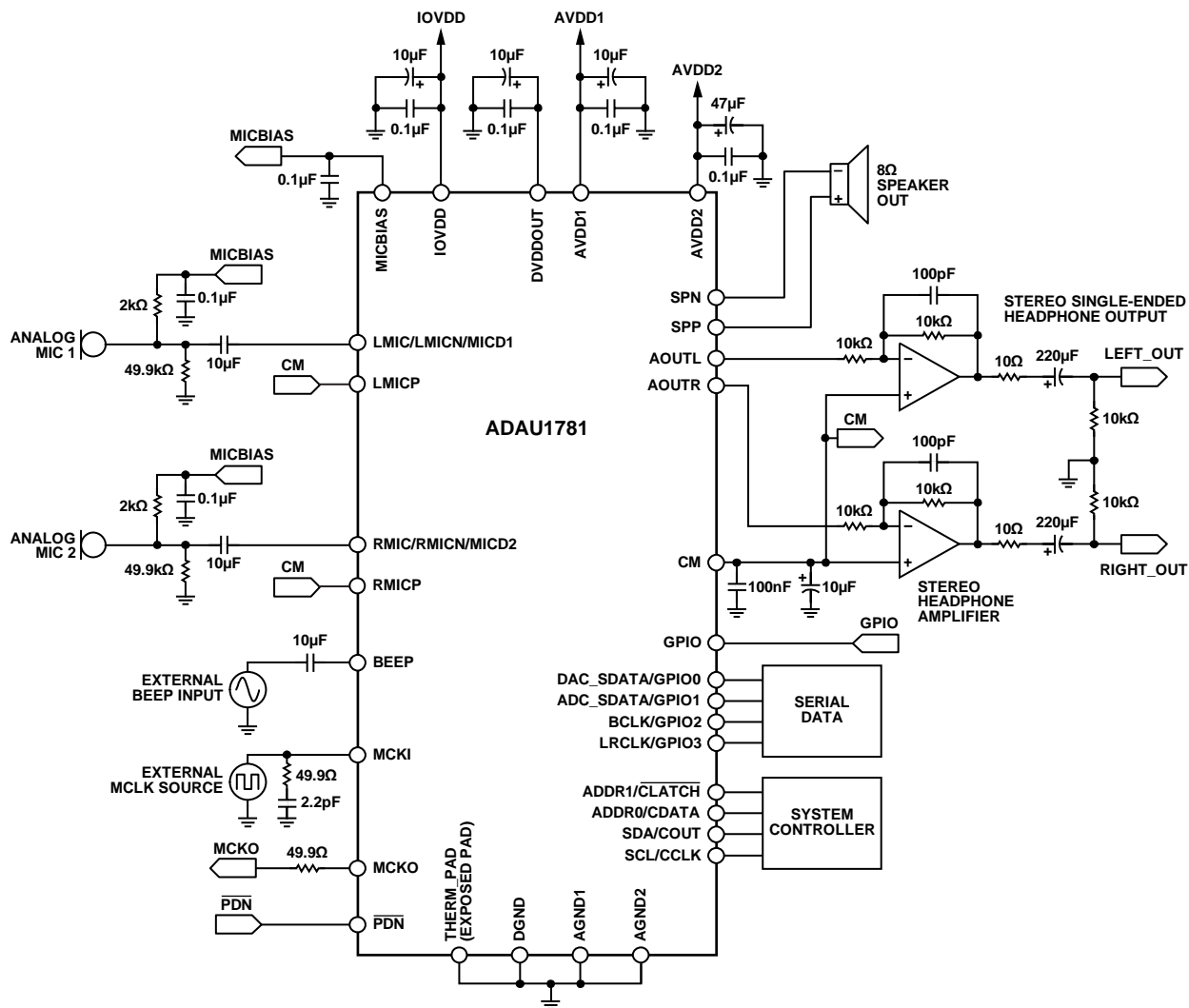

Figure 23. System Block Diagram with Analog Microphone Inputs

08314-022

ADAU1781

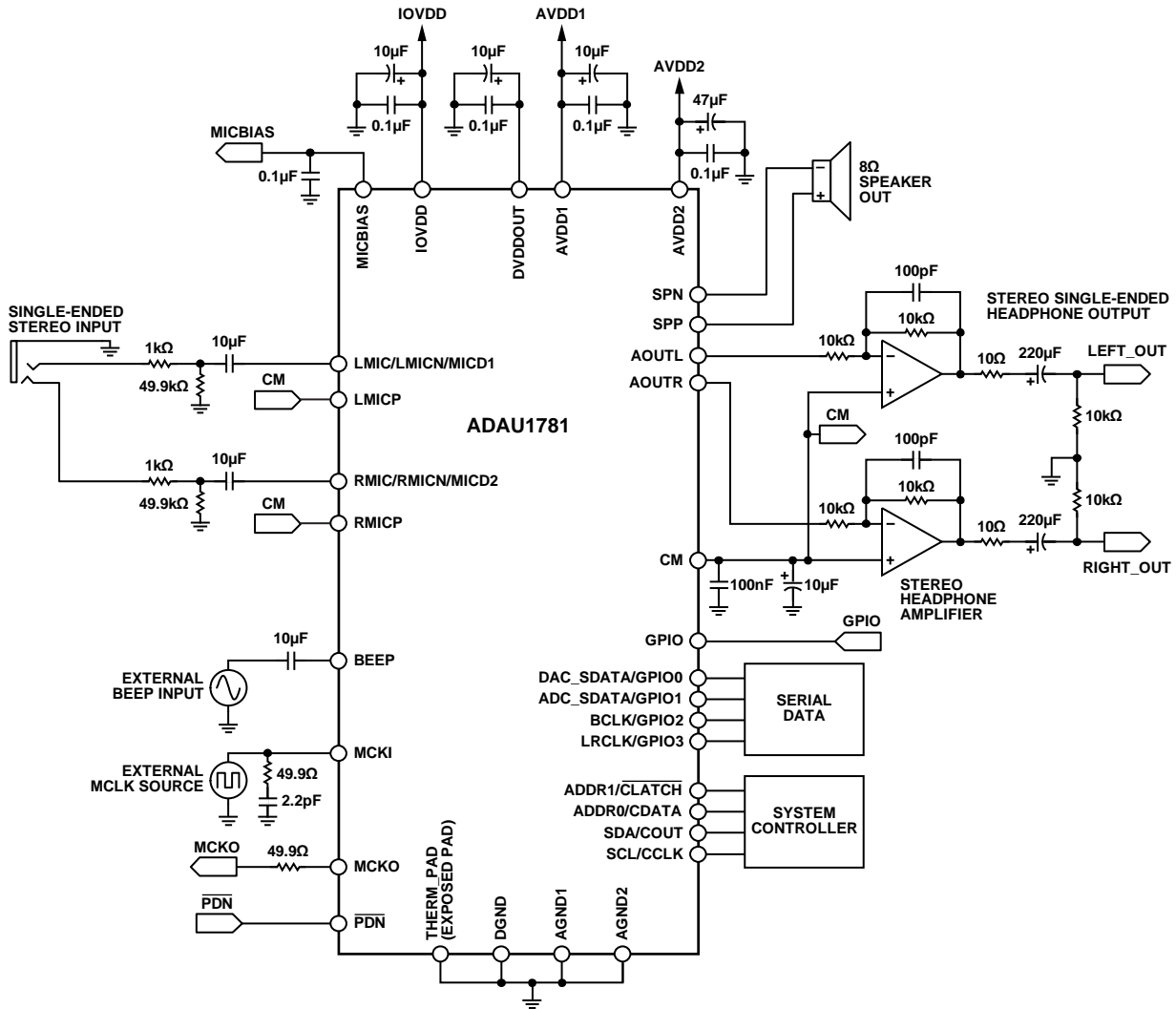

Figure 24. System Block Diagram with Single-Ended Stereo Line Inputs

08314-023

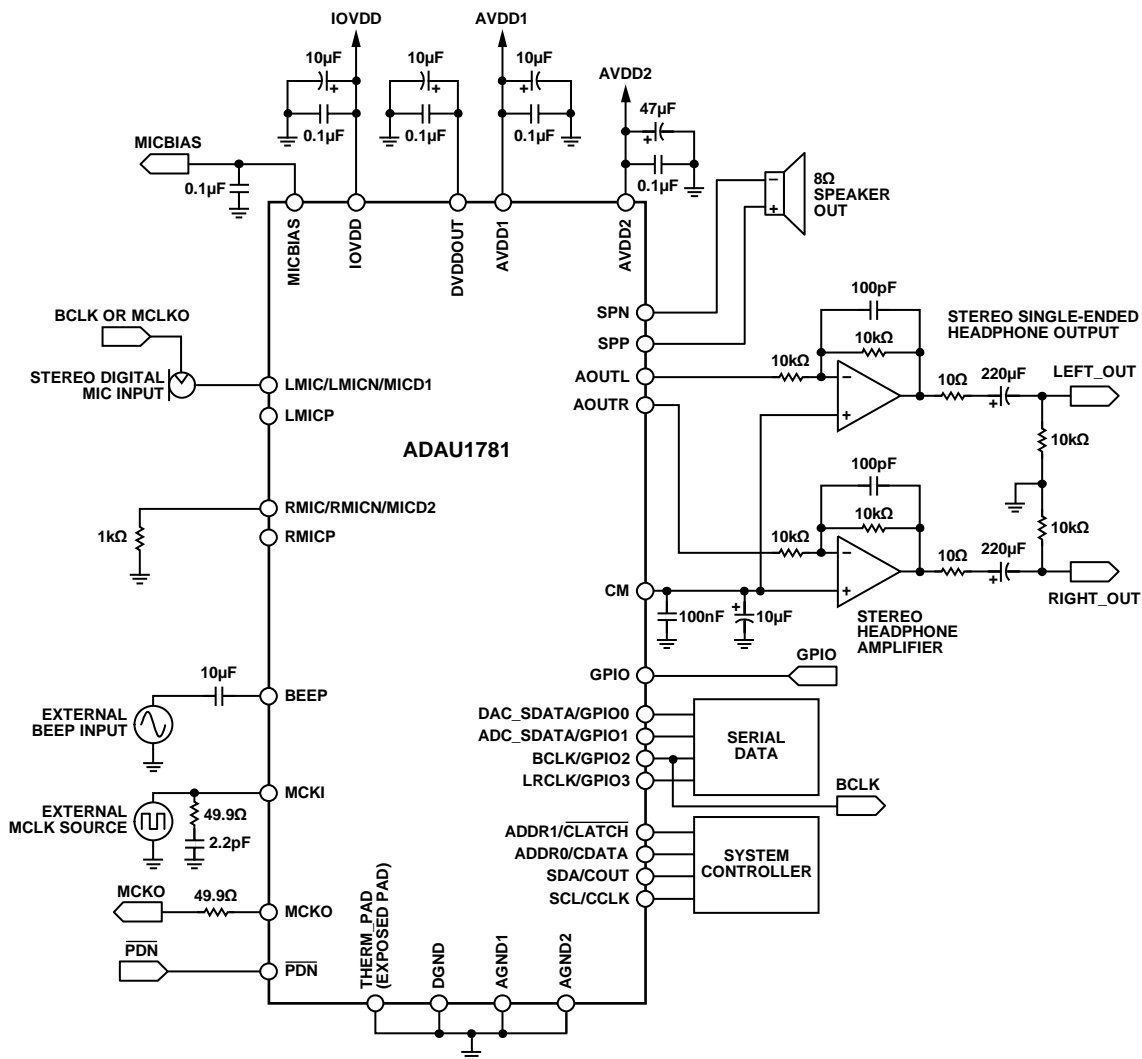

Figure 25. System Block Diagram with Stereo Digital Microphone Inputs

08314-024

THEORY OF OPERATION

The ADAU1781 is a low power audio codec with an integrated, programmable SigmaDSP audio processing core. It is an all-in-one package that offers high quality audio, low power, small size, and many advanced features. The stereo ADC and stereo DAC each have a dynamic range (DNR) performance of at least 96.5 dB and a total harmonic distortion plus noise (THD + N) performance of at least -90 dB. The serial data port is compatible with I²S, left-justified, right-justified, and TDM modes for interfacing to digital audio data. The operating voltage range is 1.8 V to 3.65 V, with an on-board regulator generating the internal digital supply voltage.

The record path includes very flexible input configurations that can accept differential or single-ended analog microphone inputs as well as two stereo digital microphone inputs. There is also a beep input pin (BEEP) dedicated to analog beep signals that are common in digital still camera applications. A microphone bias pin that can power electrets-type microphones is also available. Each input signal has its own programmable gain amplifier (PGA) for input volume adjustment. An automatic level control (ALC) can be implemented in the SigmaDSP audio processing core to maintain a constant input recording volume.

The ADCs and DACs are high quality, 24-bit Σ - Δ converters that operate at selectable 64 \times or 128 \times oversampling rates. The base sampling rate of the converters is set by the input clock rate and can be further scaled with the converter control register settings. The converters can operate at sampling frequencies from 8 kHz to 96 kHz. The ADCs and DACs also include very fine-step digital volume controls.

The playback path allows input signals and DAC outputs to be mixed into speaker and/or line outputs. The speaker driver is capable of driving 400 mW into an 8 Ω load.

The SigmaDSP audio processing core can be programmed to enhance the audio quality and improve the end-user experience. The flexibility offered by the SigmaDSP core allows this codec to be used for a wide variety of low power applications. Signal processing blocks available for use in the SigmaDSP core include the following:

- Dynamics processing, including compressors, expanders, gates, and limiters
- Chime, tone, and noise generators
- Enhanced stereo capture (ESC)
- Wind noise detection and filtering
- Stereo spatialization
- Dynamic bass
- Loudness
- Filtering, including crossover, equalization, and notch
- GPIO controls
- Mixers and multiplexers
- Volume controls and mute

The ADAU1781 can generate its internal clocks from a wide range of input clocks by using the on-board fractional PLL. The PLL accepts inputs from 11 MHz to 20 MHz.

The ADAU1781 is provided in a small, 32-lead, 5 mm \times 5 mm lead frame chip scale package (LFCSP) with an exposed bottom pad.

STARTUP, INITIALIZATION, AND POWER

This section details the procedure for setting up the ADAU1781 properly. Figure 26 provides an overview of how to initialize the IC.

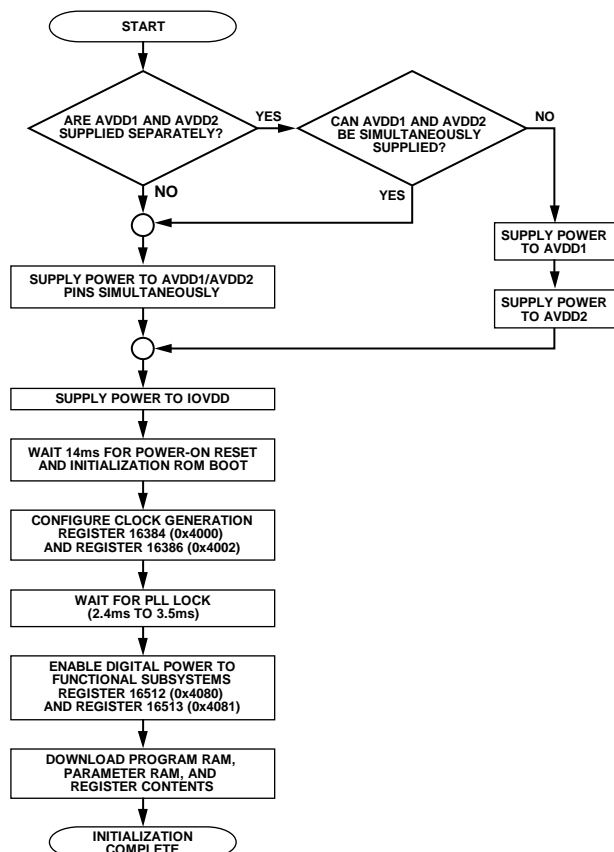

Figure 26. Initialization Sequence

POWER-UP SEQUENCE

If AVDD1 and AVDD2 are from the same supply, they can power up simultaneously. If AVDD1 and AVDD2 are from separate supplies, then AVDD1 should be powered up first. IOVDD should be applied simultaneously with AVDD1, if possible.

The ADAU1781 uses a power-on reset (POR) circuit to reset the registers upon power-up. The POR monitors the DVDDOUT pin and generates a reset signal whenever power is applied to the chip. During the reset, the ADAU1781 is set to the default values documented in the register map (see the Control Register Map section).

The POR is also used to prevent clicks and pops on the speaker driver output. The power-up sequencing and timing involved is described in Figure 27 in this section, and in Figure 35 and Figure 36 of the Speaker Output section.

A self-boot ROM initializes the memories after the POR has completed. When the self-boot sequence is complete, the control registers are accessible via the I²C/SPI control port and should then be configured as required for the application. Typically, with a 10 μ F capacitor on AVDD1, the power supply ramp-up, POR, and self-boot combined take approximately 14 ms.

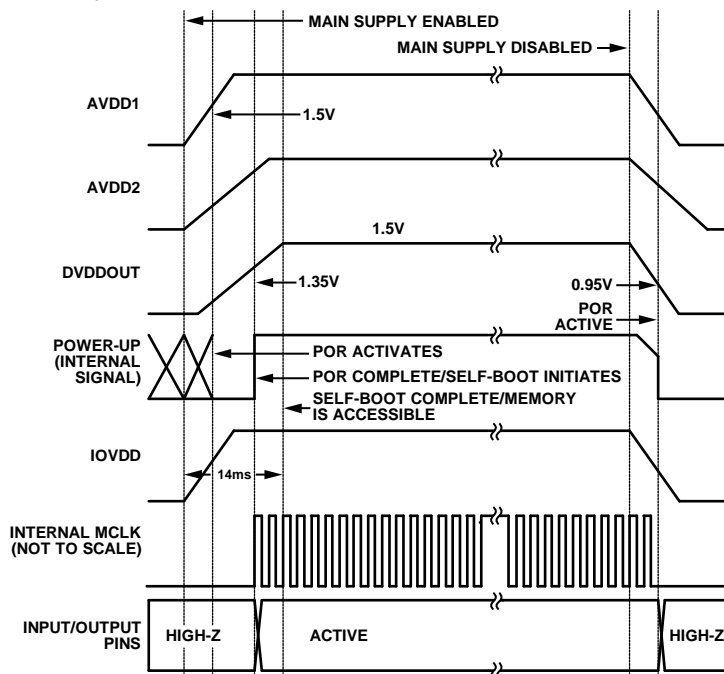

Figure 27. Power-Up and Power-Down Sequence Timing Diagram

CLOCK GENERATION AND MANAGEMENT

The ADAU1781 uses a flexible clocking scheme that enables the use of many different input clock rates. The PLL can be bypassed or used, resulting in two different approaches to clock management. For more information about clocking schemes, PLL configuration, and sampling rates, see the Clocking and Sampling Rates section.

Case 1: PLL Is Bypassed

If the PLL is bypassed, the core clock is derived directly from the master clock (MCLK) input. The rate of this clock must be set properly in Register 16384 (0x4000), clock control, Bits[2:1], input master clock frequency. When the PLL is bypassed, supported external clock rates are $256 \times f_s$, $512 \times f_s$, $768 \times f_s$, and $1024 \times f_s$, where f_s is the base sampling rate. The core clock of the chip is off until Register 16384 (0x4000), clock control, Bit 0, core clock enable, is set to 1.

Case 2: PLL Is Used

The core clock to the entire chip is off during the PLL lock acquisition period. The user can poll the lock bit to determine when the PLL has locked. After lock is acquired, the ADAU1781 can be started by setting Register 16384 (0x4000), clock control, Bit 0, core clock enable, to 1. This bit enables the core clock to all the internal functional blocks of the ADAU1781.

PLL Lock Acquisition

During the lock acquisition period, only Register 16384 (0x4000), clock control, and Register 16386 (0x4002), PLL control, are accessible through the control port. Reading from or writing to any other address is prohibited until Register 16384 (0x4000), clock control, Bit 0, core clock enable, and Register 16386 (0x4002), PLL control, Bit 1, PLL lock, are set to 1.

Register 16386 (0x4002), PLL control, is a 48-bit register for which all bits must be written with a single continuous write to the control port.

The PLL lock time is dependent on the MCLK rate. Typical lock times are provided in Table 11.

Table 11. PLL Lock Time

PLL Mode	MCLK Frequency	Lock Time (Typical)
Fractional	12 MHz	3.0 ms
Integer	12.288 MHz	2.96 ms
Fractional	13 MHz	2.4 ms
Fractional	14.4 MHz	2.4 ms
Fractional	19.2 MHz	2.98 ms
Fractional	19.68 MHz	2.98 ms
Fractional	19.8 MHz	2.98 ms

ENABLING DIGITAL POWER TO FUNCTIONAL SUBSYSTEMS

To power subsystems in the device, they must be enabled using Register 16512 (0x4080), Digital Power-Down 0, and Register 16513 (0x4081), Digital Power-Down 1. The exact settings depend on the application. However, to proceed with the initialization sequence and access the RAMs and registers of the ADAU1781, Register 16512 (0x4080), Digital Power-Down 0, Bit 6, memory controller, and Bit 0, SigmaDSP core, must be enabled.

SETTING UP THE SigmaDSP CORE

After the PLL has locked, the ADAU1781 is in an operational state, and the control port can be used to configure the SigmaDSP core. For more information, see the DSP Core section.

POWER REDUCTION MODES

Sections of the ADAU1781 chip can be turned on and off as needed to reduce power consumption. These include the ADCs, the DACs, and the PLL.

In addition, some functions can be set in the registers to operate in power saving, normal, or enhanced performance operation. See the respective portions of the General-Purpose Input/Outputs section for more information.

Each digital filter of the ADCs and DACs can be set to a 64× or 128× (default) oversampling ratio. Setting the oversampling ratio to 64× lowers power consumption with a minimal impact on performance. See the Typical Performance Characteristics section and the Typical Power Management Measurements section for specifications and graphs of the filters.

Detailed information regarding individual power reduction control registers can be found in the Control Register Map section of this document.

Power-Down Pin (\overline{PDN})

The power-down pin provides a simple hardware-based method for initiating low power mode without requiring access via the control port. When the \overline{PDN} pin is lowered to the same potential as ground, the internal digital regulator is disabled and the device ceases to function, with power consumption dropping to a very low level. The common-mode voltage sinks, and all internal memories and registers lose their contents. When the \overline{PDN} pin is raised back to the same potential as AVDD1, the device reinitializes in its default state, as described in the Power-Up Sequence section.

POWER-DOWN SEQUENCE

When powering down the device, the IOVDD, AVDD1, and AVDD2 supplies should be disabled at the same time, if possible, but only after the analog and speaker outputs have been muted. If the supplies cannot be disabled simultaneously, the preferred sequence is IOVDD first, AVDD2 second, and AVDD1 last.

CLOCKING AND SAMPLING RATES

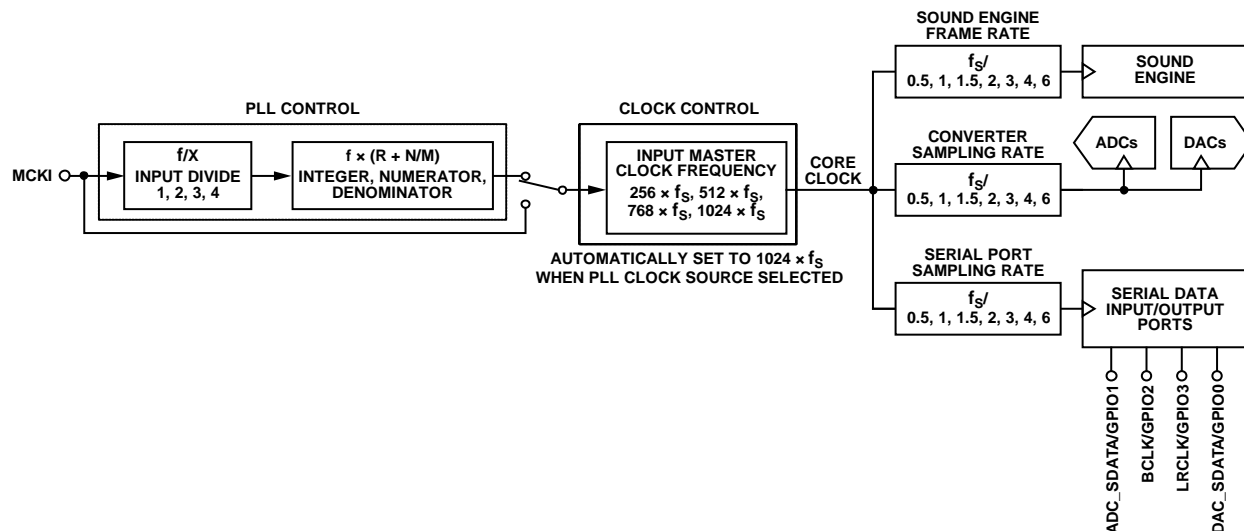

Figure 28. Clock Routing Diagram

CORE CLOCK

The core clock divider generates a core clock either from the PLL or directly from MCLK and can be set in Register 16384 (0x4000), clock control.

The core clock is always in $256 \times f_s$ mode. Direct MCLK frequencies must correspond to a value listed in Table 12, where f_s is the base sampling frequency. PLL outputs are always in $1024 \times f_s$ mode, and the clock control register automatically sets the core clock divider to $f/4$ when using the PLL.

Table 12. Core Clock Frequency Dividers

Input Clock Rate	Core Clock Divider	Core Clock
$256 \times f_s$	$f/1$	$256 \times f_s$
$512 \times f_s$	$f/2$	
$768 \times f_s$	$f/3$	
$1024 \times f_s$	$f/4$	

Clocks for the converters, the serial ports, and the SigmaDSP core are derived from the core clock. The core clock can be derived directly from MCLK, or it can be generated by the PLL. Register 16384 (0x4000), clock control, Bit 3, clock source select, determines the clock source.

Bits[2:1], input master clock frequency, should be set according to the expected input clock rate selected by Bit 3, clock source select. The clock source select value also determines the core clock rate and the base sampling frequency, f_s .

For example, if the input to Bit 3 = 49.152 MHz (from PLL), then Bits[2:1] = $1024 \times f_s$; therefore,

$$f_s = 49.152 \text{ MHz} / 1024 = 48 \text{ kHz}$$

Table 13. Clock Control Register (Register 16384, 0x4000)

Bits	Bit Name	Settings
3	Clock source select	0: direct from MCKI pin (default) 1: PLL clock
[2:1]	Input master clock frequency	00: $256 \times f_s$ (default) 01: $512 \times f_s$ 10: $768 \times f_s$ 11: $1024 \times f_s$
0	Core clock enable	0: core clock disabled (default) 1: core clock enabled

SAMPLING RATES

The ADCs, DACs, and serial port share a common sampling rate that is set in Register 16407 (0x4017), Converter Control 0. Bits[2:0], converter sampling rate, set the sampling rate as a ratio of the base sampling frequency. The SigmaDSP core sampling rate is set in Register 16619 (0x40EB), SigmaDSP core frame rate, Bits[3:0], SigmaDSP core frame rate, and the serial port sampling rate is set in Register 16632 (0x40F8), serial port sampling rate, Bits[2:0], serial port control sampling rate.

It is strongly recommended that the sampling rates for the converters, serial ports, and SigmaDSP core be set to the same value, unless appropriate compensation filtering is done within the SigmaDSP core.

ADAU1781

Table 14 and Table 15 list the sampling rate divisions for common base sampling rates.

Table 14. Base Sampling Rate Divisions for $f_s = 48$ kHz

Base Sampling Frequency	Sampling Rate Scaling	Sampling Rate
$f_s = 48$ kHz	$f_s/1$	48 kHz
	$f_s/6$	8 kHz
	$f_s/4$	12 kHz
	$f_s/3$	16 kHz
	$f_s/2$	24 kHz
	$f_s/1.5$	32 kHz
	$f_s/0.5$	96 kHz

Table 15. Base Sampling Rate Divisions for $f_s = 44.1$ kHz

Base Sampling Frequency	Sampling Rate Scaling	Sampling Rate
$f_s = 44.1$ kHz	$f_s/1$	44.1 kHz
	$f_s/6$	7.35 kHz
	$f_s/4$	11.025 kHz
	$f_s/3$	14.7 kHz
	$f_s/2$	22.05 kHz
	$f_s/1.5$	29.4 kHz
	$f_s/0.5$	88.2 kHz

PLL

The PLL uses the MCLK as a reference to generate the core clock. PLL settings are set in Register 16386 (0x4002), PLL control. Depending on the MCLK frequency, the PLL must be set for either integer or fractional mode. The PLL can accept input frequencies in the range of 11 MHz to 20 MHz.

All six bytes in the PLL control register must be written with a single continuous write to the control port.

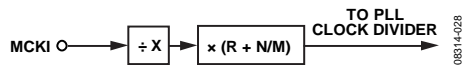

Figure 29. PLL Block Diagram

Integer Mode

Integer mode is used when the MCLK is an integer (R) multiple of the PLL output ($1024 \times f_s$).

For example, if MCLK = 12.288 MHz and $f_s = 48$ kHz, then

$$PLL \text{ Required Output} = 1024 \times 48 \text{ kHz} = 49.152 \text{ MHz}$$

$$R = 49.152 \text{ MHz} / 12.288 \text{ MHz} = 4$$

In integer mode, the values set for N and M are ignored.

Fractional Mode

Fractional mode is used when the MCLK is a fractional ($R + (N/M)$) multiple of the PLL output.

For example, if MCLK = 12 MHz and $f_s = 48$ kHz, then

$$PLL \text{ Required Output} = 1024 \times 48 \text{ kHz} = 49.152 \text{ MHz}$$

$$R + (N/M) = 49.152 \text{ MHz} / 12 \text{ MHz} = 4 + (12/125)$$

Common fractional PLL parameter settings for 44.1 kHz and 48 kHz sampling rates can be found in Table 16 and Table 17.

Table 16. Fractional PLL Parameter Settings for $f_s = 44.1$ kHz¹

MCLK Input (MHz)	Input Divider (X)	Integer (R)	Denominator (M)	Numerator (N)
12	1	3	625	477
13	1	3	8125	3849
14.4	2	6	125	34
19.2	2	4	125	88
19.68	2	4	1025	604
19.8	2	4	1375	772

¹ Desired core clock = 11.2896 MHz, PLL output = 45.1584 MHz.

Table 17. Fractional PLL Parameter Settings for $f_s = 48$ kHz¹

MCLK Input (MHz)	Input Divider (X)	Integer (R)	Denominator (M)	Numerator (N)
12	1	4	125	12
13	1	3	1625	1269
14.4	2	6	75	62
19.2	2	5	25	3
19.68	2	4	205	204
19.8	2	4	825	796

¹ Desired core clock = 12.288 MHz, PLL output = 49.152 MHz.

The PLL outputs a clock in the range of 41 MHz to 54 MHz, which should be taken into account when calculating PLL values and MCLK frequencies.

The ADC and DAC sampling rate can be set in Register 16407 (0x4017), Converter Control 0, Bits[2:0], converter sampling rate. The SigmaDSP core sampling rate and serial port sampling rate are similarly set in Register 16619 (0x40EB), SigmaDSP core frame rate, Bits[3:0], SigmaDSP core frame rate, and Register 16632 (0x40F8), serial port sampling rate, Bits[2:0], serial port control sampling rate, respectively.

Table 18 and Table 19 depict example sampling rate settings. The (1 × 256) case is the base sampling rate.

Table 18. Sampling Rates for 256 × 48 kHz Core Clock

Core Clock	Sampling Rate Divider	Sampling Rate
12.288 MHz	(1 × 256)	48 kHz
	(6 × 256)	8 kHz
	(4 × 256)	12 kHz
	(3 × 256)	16 kHz
	(2 × 256)	24 kHz
	(1.5 × 256)	32 kHz
	(0.5 × 256)	96 kHz

Table 19. Sampling Rates for 256 × 44.1 kHz Core Clock

Core Clock	Sampling Rate Divider	Sampling Rate
11.2896 MHz	(1 × 256)	44.1 kHz
	(6 × 256)	7.35 kHz
	(4 × 256)	11.025 kHz
	(3 × 256)	14.7 kHz
	(2 × 256)	22.05 kHz
	(1.5 × 256)	29.4 kHz
	(0.5 × 256)	88.2 kHz

RECORD SIGNAL PATH

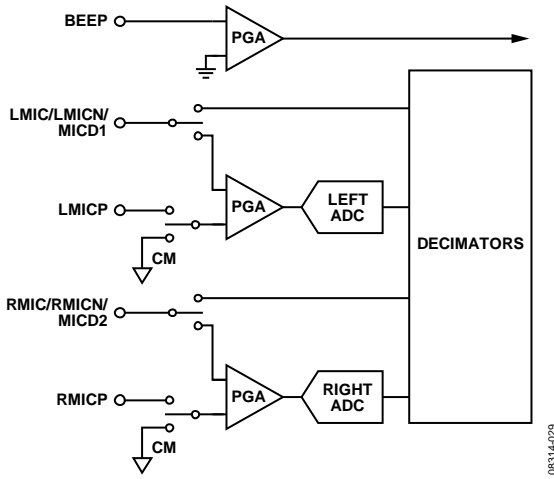

Figure 30. Record Signal Path Diagram

INPUT SIGNAL PATH

The ADAU1781 can be configured for three types of microphone inputs: single-ended, differential, or digital. The LMIC/LMICN/MICD1 and RMIC/RMICN/MICD2 pins encompass all of these configurations. LMICP and RMICP are used only during differential configurations (see Figure 30, the record signal path diagram).

Each analog input has individual gain controls (boost or cut). These signals are routed to their respective right or left channel ADC.

Analog Microphone Inputs

For differential inputs, RMICN and RMICP denote the negative and positive input for the right channel, respectively. LMICN and LMICP denote the negative and positive input for the left channel, respectively.

LMIC and RMIC inputs are single-ended line inputs. Together, they can be used as a stereo single-ended input.

Digital Microphone Inputs

When a digital PDM microphone connected to the MICD1 or MICD2 pin is used, Register 16392 (0x4008), digital microphone and analog beep control, must be set appropriately to enable the microphone input of choice. The MCKO output clock provides the clock for the microphone and must be set accordingly in Register 16384 (0x4000), clock control, depending on the streaming PDM rate of the microphone.

The digital microphone signal bypasses the ADCs and is routed directly into the decimation filters. The digital microphone and ADCs share these decimation filters; therefore, both cannot be used simultaneously.

Analog Beep Input

The BEEP pin is used for mono single-ended signals, such as a beep warning. This signal bypasses the ADCs and the SigmaDSP core and is mixed directly into any of the analog outputs.

A BEEP pin input can also be amplified or muted by a PGA, up to 32 dB in Register 16392 (0x4008), digital microphone and analog beep control. The beep input must be enabled in Register 16400 (0x4010), microphone bias control and beep enable.

Microphone Bias

The MICBIAS pin provides a voltage reference for electret microphones. Register 16400 (0x4010), microphone bias control and beep enable, sets the operation mode of this pin.

Example Configurations

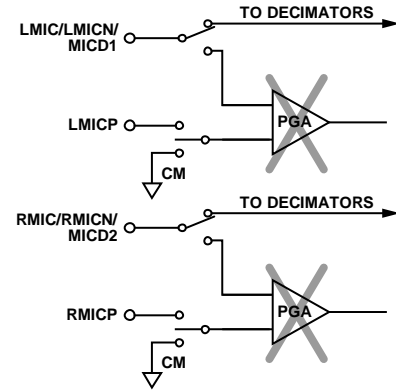

Figure 31. Stereo Digital Microphone Input Configuration

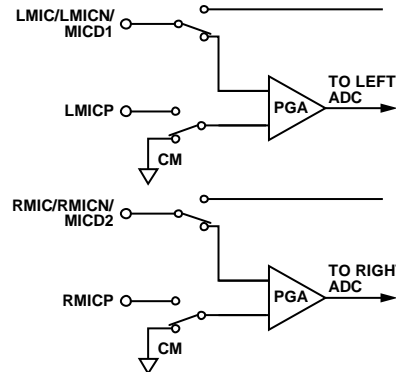

Figure 32. Single-Ended Input Configuration

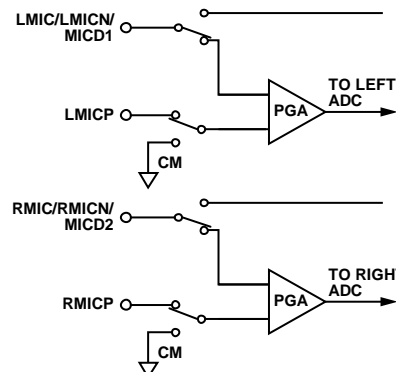

Figure 33. Differential Input Configuration

ANALOG-TO-DIGITAL CONVERTERS

The ADAU1781 uses two 24-bit Σ - Δ analog-to-digital converters (ADCs) with selectable oversampling rates of either 64 \times or 128 \times . The full-scale input to the ADCs depends on AVDD1. At 3.3 V, the full-scale input level is 1.0 V rms. Inputs greater than the full-scale value result in clipping and distortion.

Digital ADC Volume Control

The ADC output (digital input) volume can be adjusted in Register 16410 (0x401A), left ADC attenuator, Bits[7:0], left

ADC digital attenuator, for the left channel digital volume control and in Register 16411 (0x401B), right ADC attenuator, Bits[7:0], right ADC digital attenuator, for right channel digital volume control.

High-Pass Filter

A high-pass filter is used in the ADC path to remove dc offsets and can be selected in Register 16409 (0x4019), ADC control, Bit 5, high-pass filter select, where it can be enabled or disabled.

PLAYBACK SIGNAL PATH

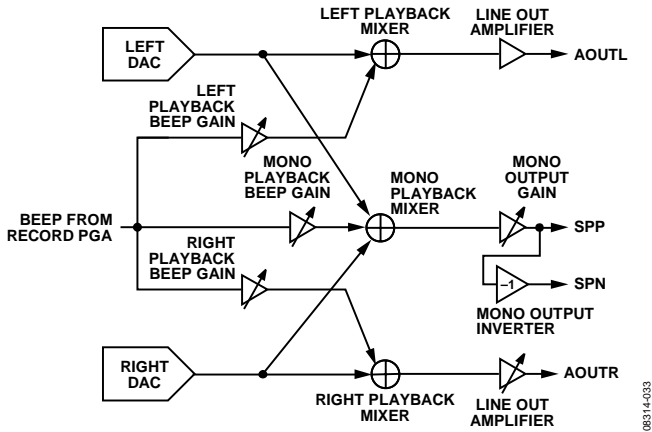

Figure 34. Playback Signal Path Diagram

OUTPUT SIGNAL PATHS

The outputs of the ADAU1781 include a left and right line output and speaker driver. The beep input signal can be mixed into any of these outputs, with separate gain control for each path.

DIGITAL-TO-ANALOG CONVERTERS

The ADAU1781 uses two 24-bit Σ - Δ digital-to-analog converters (DACs) with selectable oversampling rates of 64 \times or 128 \times . The full-scale output of the DACs depends on AVDD1. At 3.3 V, the full-scale output level is 1.0 V rms.

Digital DAC Volume Control

The DAC output (digital output) volume can be adjusted in Register 16427 (0x402B), left DAC attenuator, for the left channel digital volume control and in Register 16428 (0x402C), right DAC attenuator, for the right channel digital volume control.

De-Emphasis Filter

A de-emphasis filter is used in the DAC path to remove high frequency noise in an FM system. This filter can be enabled or disabled in Register 16426 (0x402A), DAC control.

LINE OUTPUTS

The AOUTL and AOUTR pins are the left and right line outputs, respectively. Both outputs have a line output amplifier that can be set in the control registers.

The left playback mixer is dedicated to the AOUTL output. This mixer mixes the left DAC and the beep signal.

Similarly, the right playback mixer mixes the right DAC and the beep input and is dedicated to the AOUTR output.

SPEAKER OUTPUT

The SPP and SPN pins are the positive and negative speaker outputs, respectively. Each output has a speaker driver.

The speaker outputs are derived from the mono playback mixer, which sums the right and left DAC outputs and mixes with the beep signal. The mixer can be controlled in Register 16415 (0x401F), playback mono mixer control.

The drivers are low noise, Class AB mono amplifiers designed to drive 8 Ω , 400 mW speakers. The output is differential and does not require external capacitors. The gain settings for the speaker drivers can be set in Register 16423 (0x4027), playback speaker output control. In this register, the drivers can be set for any of the four gain settings: 0 dB, 2 dB, 4 dB, or 6 dB. Additionally, the speaker driver can be muted or powered down completely.

For pop and click suppression, an internal precharge sequence with output gating/enabling occurs after the mono driver is enabled. The sequence lasts for 8 ms, and then the internal mute signal rising edge occurs (see Figure 35 for the power-up sequence timing diagram).

The power-down sequence is essentially the reverse of the start-up sequence, as depicted in Figure 36.

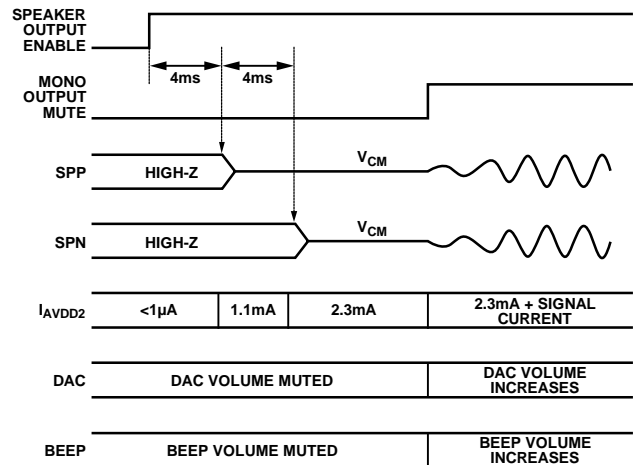

Figure 35. Speaker Driver Power-Up Sequence

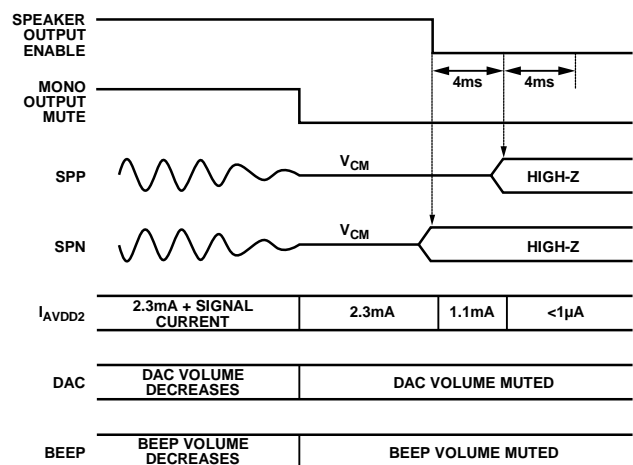

Figure 36. Speaker Driver Power-Down Sequence

CONTROL PORTS

The ADAU1781 can operate in one of two control modes: I²C control or SPI control.

The ADAU1781 has both a 4-wire SPI control port and a 2-wire I²C bus control port. Each can be used to set the registers. The part defaults to I²C mode but can be put into SPI control mode by pulling the CLATCH pin low three times.

The control port is capable of full read/write operation for all addressable registers. Most SigmaDSP core processing parameters are controlled by writing new values to the parameter RAM using the control port. Other functions, such as mute, input/output mode control, and analog signal paths, can be programmed by writing to the appropriate registers.

All addresses can be accessed in either a single-address mode or a burst mode. The first byte (Byte 0) of a control port write contains the 7-bit chip address plus the R/W bit. The next two bytes (Byte 1 and Byte 2) together form the subaddress of the register location within the ADAU1781. All subsequent bytes (starting with Byte 3) contain the data, such as control port data, register data, or parameter RAM data. The number of bytes per word depends on the type of data that is being written. The exact formats for specific types of writes and reads are shown in Figure 39 to Figure 42.

The ADAU1781 has several mechanisms for updating audio processing parameters in real time without causing pops or clicks. The control port pins are multifunctional, depending on the mode in which the part is operating. Table 20 details these multiple functions.

Table 20. Control Port Pin Functions

Pin	I ² C Mode	SPI Mode
SCL/CCLK	SCL—input	CCLK—input
SDA/COU	SDA—open-collector output	COU—output
ADDR1/CLATCH	I ² C Address Bit 1—input	CLATCH—input
ADDR0/CDATA	I ² C Address Bit 0—input	CDATA—input

I²C PORT

The ADAU1781 supports a 2-wire serial (I²C-compatible) microprocessor bus driving multiple peripherals. Two pins, serial data (SDA) and serial clock (SCL), carry information between the ADAU1781 and the system I²C master controller. In I²C mode, the ADAU1781 is always a slave on the bus, meaning it cannot initiate a data transfer. Each slave device is recognized by a unique address. The address byte format is shown in Table 21. The address resides in the first seven bits of the I²C write. The LSB of this byte sets either a read or write operation. Logic 1 corresponds to a read operation, and Logic 0 corresponds to a write operation. The full byte addresses, including the pin settings and R/W bit, are shown in Table 22.

Burst mode addressing, where the subaddresses are automatically incremented at word boundaries, can be used for writing large amounts of data to contiguous memory locations. This increment happens automatically after a single-word write unless a stop condition is encountered. The registers in the ADAU1781 range in width from one to six bytes; therefore, the auto-increment feature knows the mapping between subaddresses and the word length of the destination register. A data transfer is always terminated by a stop condition.

Both SDA and SCL should have 2.0 kΩ pull-up resistors on the lines connected to them. The voltage on these signal lines should not be more than AVDD1.

Table 21. I²C Address Byte Format

Bit 0	Bit 1	Bit 2	Bit 3	Bit 4	Bit 5	Bit 6	Bit 7
0	1	1	1	0	ADDR1	ADDR0	R/W

Table 22. I²C Addresses

ADDR1	ADDR0	R/W	Slave Address
0	0	0	0x70
0	0	1	0x71
0	1	0	0x72
0	1	1	0x73
1	0	0	0x74
1	0	1	0x75
1	1	0	0x76
1	1	1	0x77

Addressing

Initially, each device on the I²C bus is in an idle state and monitoring the SDA and SCL lines for a start condition and the proper address. The I²C master initiates a data transfer by establishing a start condition, defined by a high-to-low transition on SDA while SCL remains high. This indicates that an address or an address and data stream follow. All devices on the bus respond to the start condition and shift the next eight bits (the 7-bit address plus the R/W bit), MSB first. The device that recognizes the transmitted address responds by pulling the data line low during the ninth clock pulse. This ninth bit is known as an acknowledge bit. All other devices withdraw from the bus at this point and return to the idle condition.

The R/W bit determines the direction of the data. A Logic 0 on the LSB of the first byte means the master writes information to the peripheral, whereas a Logic 1 means the master reads information from the peripheral after writing the subaddress and repeating the start address. A data transfer takes place until a stop condition is encountered. A stop condition occurs when SDA transitions from low to high while SCL is held high. Figure 37 shows the timing of an I²C write, and Figure 38 shows an I²C read.

ADAU1781

Stop and start conditions can be detected at any stage during the data transfer. If these conditions are asserted out of sequence with normal read and write operations, the ADAU1781 immediately jumps to the idle condition. During a given SCL high period, the user should issue only one start condition, one stop condition, or a single stop condition followed by a single start condition. If an invalid subaddress is issued by the user, the ADAU1781 does not issue an acknowledge and returns to the idle condition. If the user exceeds the highest subaddress while

in auto-increment mode, one of two actions is taken. In read mode, the ADAU1781 outputs the highest subaddress register contents until the master device issues a no acknowledge, indicating the end of a read. A no-acknowledge condition is where the SDA line is not pulled low on the ninth clock pulse on SCL. If the highest subaddress location is reached while in write mode, a no acknowledge is issued by the ADAU1781, and the part returns to the idle condition.

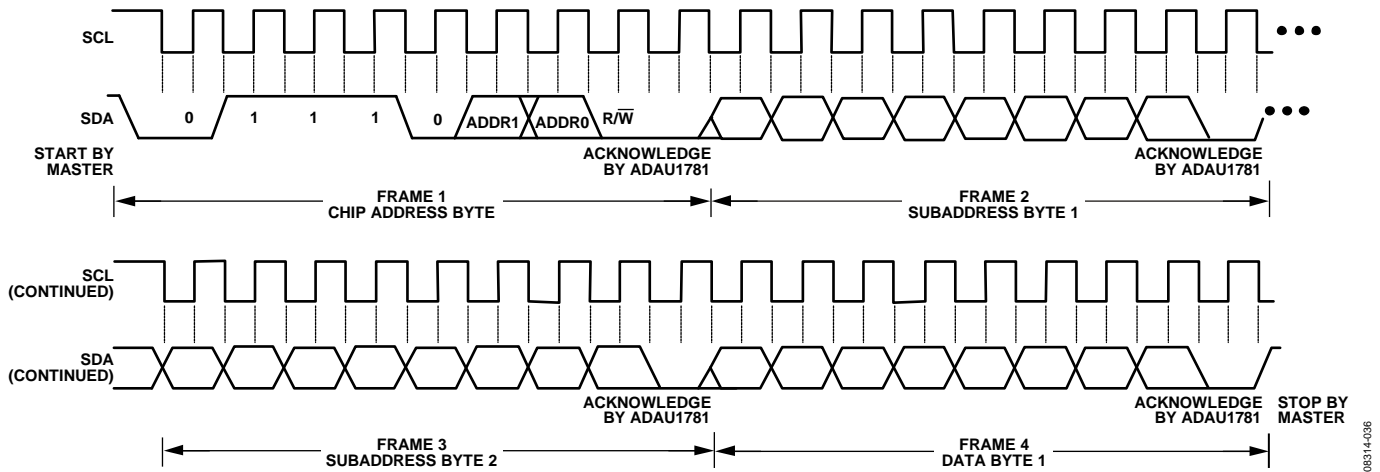

Figure 37. I²C Write to ADAU1781 Clcking

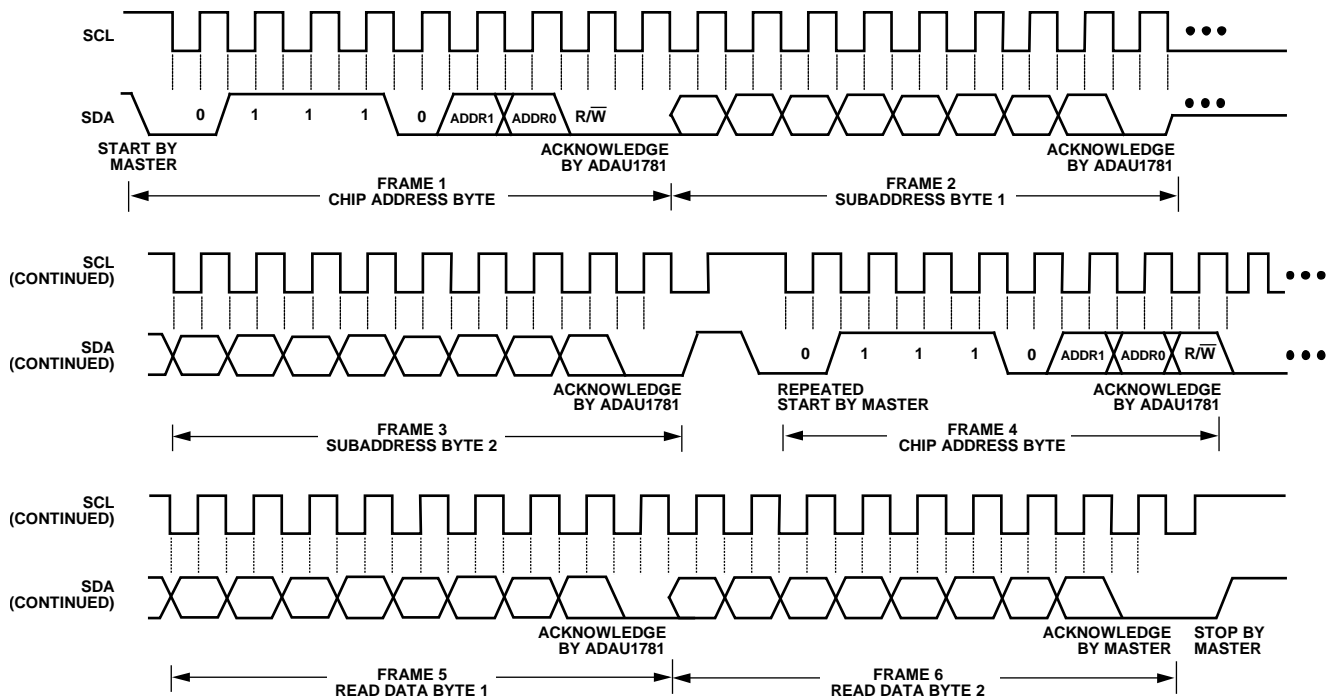

Figure 38. I²C Read from ADAU1781 Clcking

I²C Read and Write Operations

Figure 39 shows the timing of a single-word write operation. Every ninth clock pulse, the ADAU1781 issues an acknowledge by pulling SDA low.

Figure 40 shows the timing of a burst mode write sequence. This figure shows an example where the target destination registers are two bytes. The ADAU1781 knows to increment its subaddress register every two bytes because the requested subaddress corresponds to a register or memory area with a 2-byte word length.

The timing of a single-word read operation is shown in Figure 41. Note that the first R/W bit is 0, indicating a write operation. This is because the subaddress still needs to be written to set up the internal address. After the ADAU1781 acknowledges the receipt

of the subaddress, the master must issue a repeated start command followed by the chip address byte with the R/W bit set to 1 (read). This causes the ADAU1781 SDA to reverse and begin driving data back to the master. The master then responds every ninth pulse with an acknowledge pulse to the ADAU1781.

Figure 42 shows the timing of a burst mode read sequence. This figure shows an example where the target read registers are two bytes. The ADAU1781 increments its subaddress every two bytes because the requested subaddress corresponds to a register or memory area with word lengths of two bytes. Other address ranges may have a variety of word lengths ranging from one to five bytes. The ADAU1781 always decodes the subaddress and sets the auto-increment circuit so that the address increments after the appropriate number of bytes.

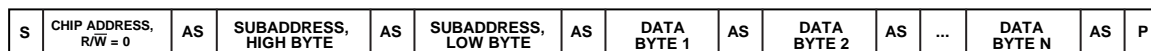

S = START BIT, P = STOP BIT, AS = ACKNOWLEDGE BY SLAVE. SHOWS A ONE-WORD WRITE, WHERE EACH WORD HAS N BYTES.

Figure 39. Single-Word I²C Write Sequence

08314-038

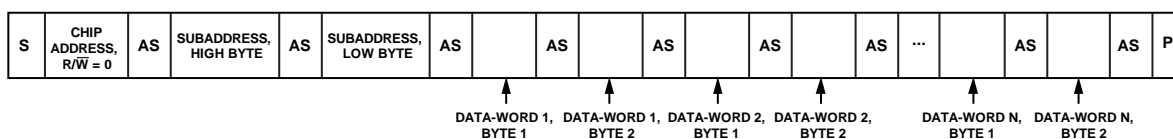

S = START BIT, P = STOP BIT, AS = ACKNOWLEDGE BY SLAVE. SHOWS AN N-WORD WRITE, WHERE EACH WORD HAS TWO BYTES. (OTHER WORD LENGTHS ARE POSSIBLE, RANGING FROM ONE TO FIVE BYTES.)

Figure 40. Burst Mode I²C Write Sequence

08314-039



S = START BIT, P = STOP BIT, AM = ACKNOWLEDGE BY MASTER, AS = ACKNOWLEDGE BY SLAVE. SHOWS A ONE-WORD READ, WHERE EACH WORD HAS N BYTES.

Figure 41. Single-Word I²C Read Sequence

08314-040

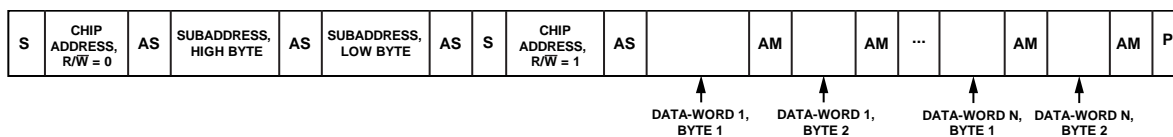

S = START BIT, P = STOP BIT, AM = ACKNOWLEDGE BY MASTER, AS = ACKNOWLEDGE BY SLAVE. SHOWS AN N-WORD READ, WHERE EACH WORD HAS TWO BYTES. (OTHER WORD LENGTHS ARE POSSIBLE, RANGING FROM ONE TO FIVE BYTES.)

Figure 42. Burst Mode I²C Read Sequence

08314-041

ADAU1781

SPI PORT

By default, the ADAU1781 is in I²C mode, but can be put into SPI control mode by pulling $\overline{\text{CLATCH}}$ low three times. The SPI port uses a 4-wire interface, consisting of $\overline{\text{CLATCH}}$, $\overline{\text{CCLK}}$, $\overline{\text{CDATA}}$, and $\overline{\text{COUT}}$ signals, and is always a slave port. The $\overline{\text{CLATCH}}$ signal goes low at the beginning of a transaction and high at the end of a transaction. The $\overline{\text{CCLK}}$ signal latches $\overline{\text{CDATA}}$ on a low-to-high transition. $\overline{\text{COUT}}$ data is shifted out of the ADAU1781 on the falling edge of $\overline{\text{CCLK}}$ and should be clocked into a receiving device, such as a microcontroller, on the $\overline{\text{CCLK}}$ rising edge. The $\overline{\text{CDATA}}$ signal carries the serial input data, and the $\overline{\text{COUT}}$ signal is the serial output data. The $\overline{\text{COUT}}$ signal remains three-stated until a read operation is requested. This allows other SPI-compatible peripherals to share the same readback line. All SPI transactions have the same basic format shown in Table 24. A timing diagram is shown in Figure 4. All data should be written MSB first. The ADAU1781 can be taken out of SPI mode only by a full reset.

Chip Address $\overline{\text{R/W}}$

The first byte of an SPI transaction includes the 7-bit chip address and an $\overline{\text{R/W}}$ bit. The chip address is always 0x38. The LSB of this first byte determines whether the SPI transaction is a read (Logic 1) or a write (Logic 0).

Table 23. SPI Address Byte Format

Bit 0	Bit 1	Bit 2	Bit 3	Bit 4	Bit 5	Bit 6	Bit 7
0	0	0	0	0	0	0	$\overline{\text{R/W}}$

Subaddress

The 12-bit subaddress word is decoded into a location in one of the registers. This subaddress is the location of the appropriate register. The MSBs of the subaddress are zero-padded to bring the word to a full 2-byte length.

Table 24. Generic Control Word Format

Byte 0	Byte 1	Byte 2	Byte 3	Byte 4 ¹
CHIP_ADR[6:0], $\overline{\text{R/W}}$	SUBADR[15:8]	SUBADR[7:0]	Data	Data

¹ Continues to end of data.

Data Bytes

The number of data bytes varies according to the register being accessed. During a burst mode write, an initial subaddress is written followed by a continuous sequence of data for consecutive register locations. A sample timing diagram for a single-write SPI operation to the parameter memory is shown in Figure 43. A sample timing diagram of a single-read SPI operation is shown in Figure 44. The $\overline{\text{COUT}}$ pin goes from three-state to being driven at the beginning of Byte 3. In this example, Byte 0 to Byte 2 contain the addresses and $\overline{\text{R/W}}$ bit, and subsequent bytes carry the data.

SPI Read/Write Clock Frequency (CCLK)

The SPI port of the ADAU1781 has asymmetrical read and write clock frequencies. It is possible to write data into the device at higher data rates than reading data out of the device. More detailed information is available in the Digital Timing Specifications section.

MEMORY AND REGISTER ACCESS

Several conditions must be true to have full access to all memory and registers via the control port:

- The ADAU1781 must have finished its initialization, including power-on reset, PLL lock, and self-boot.
- The core clock must be enabled (Register 16384 (0x4000), clock control, Bit 0, core clock enable, set to 1).
- The memory controller must be powered (Register 16512 (0x4080), Digital Power-Down 0, Bit 6, memory controller, set to 1).
- The SigmaDSP core must be powered (Register 16512 (0x4080), Digital Power-Down 0, Bit 0, SigmaDSP core, set to 1).

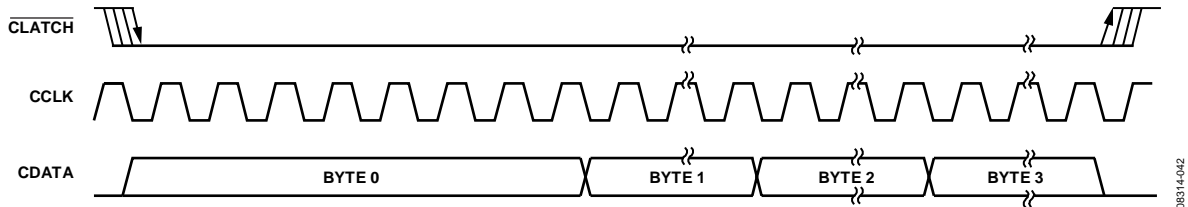

Figure 43. SPI Write to ADAU1781 Clocking (Single-Write Mode)

08314-042

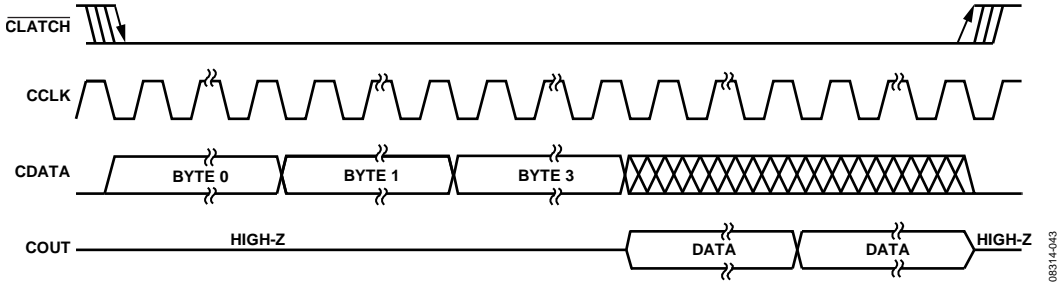

Figure 44. SPI Read from ADAU1781 Clocking (Single-Read Mode)

08314-043

SERIAL DATA INPUT/OUTPUT PORTS

The flexible serial data input and output ports of the ADAU1781 can be set to accept or transmit data in 2-channel format or in a 4-channel or 8-channel TDM stream to interface to external ADCs or DACs. Data is processed by default in twos complement, MSB first format, unless otherwise configured in the control registers. By default, the left channel data field precedes the right channel data field in 2-channel streams. In TDM 4 mode, Slot 0 and Slot 1 are in the first half of the audio frame, and Slot 2 and Slot 3 are in the second half of the audio frame. In TDM 8 mode, Slot 0 to Slot 3 are in the first half of the audio frame, and Slot 4 to Slot 7 are in the second half of the frame. The serial modes and the position of the data in the frame are set in Register 16405 (0x4015), Serial Port Control 0; Register 16406 (0x4016), Serial Port Control 1; Register 16407 (0x4017), Converter Control 0; and Register 16408 (0x4018), Converter Control 1.

The serial data clocks must be synchronous with the ADAU1781 master clock input. The LRCLK and BCLK pins are used to clock both the serial input and output ports. The ADAU1781 can be set as the master or the slave in a system. Because there is only one set of serial data clocks, the input and output ports must always be both master or both slave.

Register 16405 (0x4015), Serial Port Control 0, and Register 16406 (0x4016), Serial Port Control 1, allow control of clock polarity and data input modes. The valid data formats are I²S, left-justified, right-justified (24-/20-/18-/16-bit), and TDM. In all modes except for the right-justified modes, the serial port inputs an arbitrary number of audio data bits, up to a limit of 24. Extra bits do not cause an error, but they are truncated internally. The serial port can operate with an arbitrary number of BCLK transitions in each LRCLK frame.

Table 26. Data Format Configurations

Format	LRCLK Polarity	LRCLK Mode	BCLK Polarity	BCLK Cycles/ Audio Frame	Data Delay from LRCLK Edge
I ² S (see Figure 46)	Frame begins on falling edge	50% duty cycle	Data changes on falling edge	64	Delayed from LRCLK edge by 1 BCLK
Left-Justified (see Figure 47)	Frame begins on rising edge	50% duty cycle	Data changes on falling edge	64	Aligned with LRCLK edge
Right-Justified (see Figure 48)	Frame begins on rising edge	50% duty cycle	Data changes on falling edge	64	Delayed from LRCLK edge by 8, 12, or 16 BCLKs to align LSB with right edge of frame.
TDM with Clock (see Figure 49)	Frame begins on falling edge	50% duty cycle	Data changes on falling edge	64 to 256	Delayed from start of word clock by 1 BCLK
TDM with Pulse (see Figure 50)	Frame begins on rising edge	Pulse	Data changes on falling edge	64 to 256	Delayed from start of word clock by 1 BCLK

TDM MODES

The LRCLK in TDM mode can be input to the ADAU1781 either as a 50% duty cycle clock or as a bit-wide pulse.

When the LRCLK is set as a pulse, a 47 pF capacitor should be connected between the LRCLK pin and ground, as shown in Figure 45. This is necessary in both master and slave modes to properly align the LRCLK signal to the serial data stream.

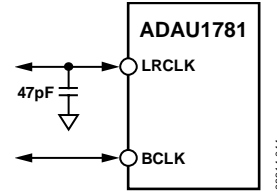

Figure 45. TDM Pulse Mode LRCLK Capacitor Alignment

The ADAU1781 TDM implementation is a TDM audio stream. Unlike a true TDM bus, its output does not become high impedance during periods when it is not transmitting data.

In TDM 8 mode, the ADAU1781 can be a master for f_s up to 48 kHz. Table 25 lists the modes in which the serial output port can function.

Table 25. Serial Output Port Master/Slave Mode Capabilities

f_s	2-Channel Modes (I ² S, Left-Justified, Right-Justified)	8-Channel TDM
48 kHz	Master and slave	Master and slave
96 kHz	Master and slave	Slave

Table 26 describes the proper configurations for standard audio data formats. Right-justified modes must be configured manually using Register 16406 (0x4016), Serial Port Control 1, Bits[7:5], number of bit clock cycles per frame, and Bits[1:0], data delay from LRCLK edge.

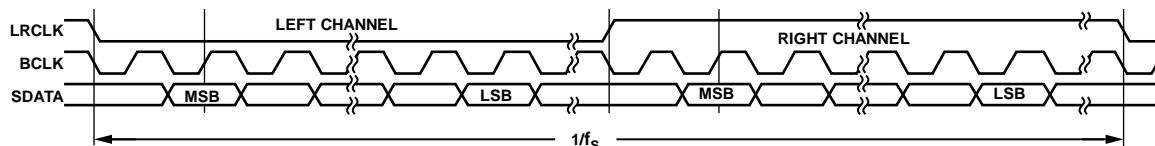

Figure 46. I²S Mode—16 Bits to 24 Bits per Channel

08314-045

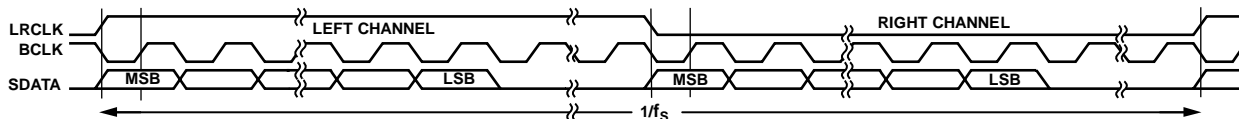

Figure 47. Left-Justified Mode—16 Bits to 24 Bits per Channel

08314-046

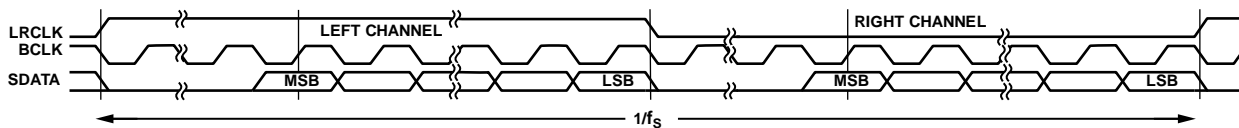

Figure 48. Right-Justified Mode—16 Bits to 24 Bits per Channel

08314-047

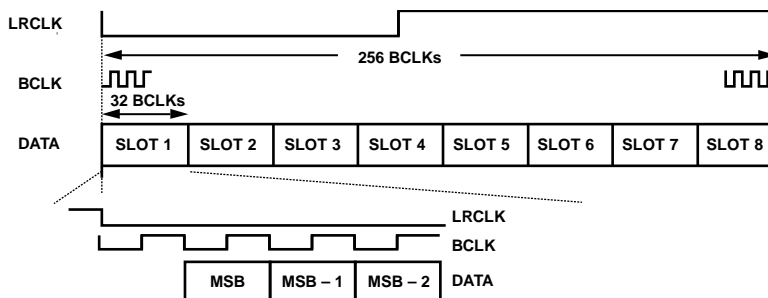

Figure 49. TDM Mode

08314-048

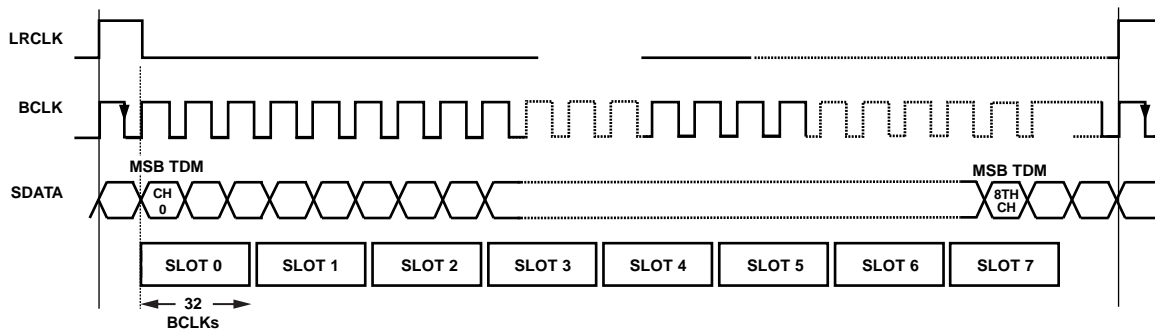

Figure 50. TDM Mode with Pulse Word Clock

08314-049

GENERAL-PURPOSE INPUT/OUTPUTS

The serial data input/output pins are shared with the general-purpose input/output function. Each of these four pins can be set to only one function. The function of these pins is set in Register 16628 (0x40F4), serial data/GPIO pin configuration.

The GPIO pins can be used as either inputs or outputs. These pins are readable and can be set either through the control interface or directly by the SigmaDSP core. When set as inputs, these pins can be used with push-button switches or rotary encoders to control SigmaDSP core program settings. Digital outputs can be used to drive LEDs or external logic to indicate the status of internal signals and control other devices. Examples of this use include indicating signal overload, signal present, and button press confirmation.

When set as an output, each pin can typically drive 2 mA. This is enough current to directly drive some high efficiency LEDs. Standard LEDs require about 20 mA of current and can be driven

from a GPIO output with an external transistor or buffer. Because of issues that may arise from simultaneously driving or sinking a large current on many pins, care should be taken in the application design to avoid connecting high efficiency LEDs directly to many or all of the GPIO pins. If many LEDs are required, use an external driver. When the GPIO pins are set as open-collector outputs, they should be pulled up to a maximum voltage of what is set on IOVDD.

The configuration of the GPIO functions is set up in Register 16582 to Register 16586 (0x40C6 to 0x40CA), GPIO pin control.

GPIOs Set from Control Port

The GPIO pins can also be set to be directly controlled from the I²C/SPI control port. When the pins are set into this mode, five memory locations are enabled for the GPIO pin settings (see Table 75). The physical settings on the GPIO pins mirror the settings of the LSB of these 4-byte-wide memory locations.

DSP CORE

SIGNAL PROCESSING

The ADAU1781 is designed to provide all audio signal processing functions commonly used in stereo or mono low power record and playback systems. The signal processing flow is designed using the SigmaStudio™ software, which allows graphical entry and real-time control of all signal processing functions.

Many of the signal processing functions are coded using full, 56-bit, double-precision arithmetic data. The input and output word lengths of the DSP core are 24 bits. Four extra headroom bits are used in the processor to allow internal gains of up to 24 dB without clipping. Additional gains can be achieved by initially scaling down the input signal in the DSP signal flow.

ARCHITECTURE

The DSP core consists of a simple 28-/56-bit multiply-accumulate unit (MAC) with two sources: a data source and a coefficient source. The data source can come from the data RAM, a ROM table of commonly used constant values, or the audio inputs to the core. The coefficient source can come from the parameter RAM, a ROM table of commonly used constant values, or the audio inputs to the core.

The two sources are multiplied in a 28-bit fixed-point multiplier, and then the signal is input to the 56-bit adder; the result is usually stored in one of three 56-bit accumulator registers. The accumulators can be output from the core (in 28-bit format) or can optionally be written back into the data or parameter RAMs.

PROGRAM COUNTER

The execution of instructions in the core is governed by a program counter, which sequentially steps through the addresses of the program RAM. The program counter starts every time a new audio frame is clocked into the core. SigmaStudio inserts a jump-to-start command at the end of every program. The program counter increments sequentially until reaching this command and then jumps to the program start address and waits for the next audio frame to clock into the core.

FEATURES

The SigmaDSP core was designed specifically for audio processing and therefore includes several features intended for maximizing efficiency. These include hardware decibel conversion and audio-specific ROM constants.

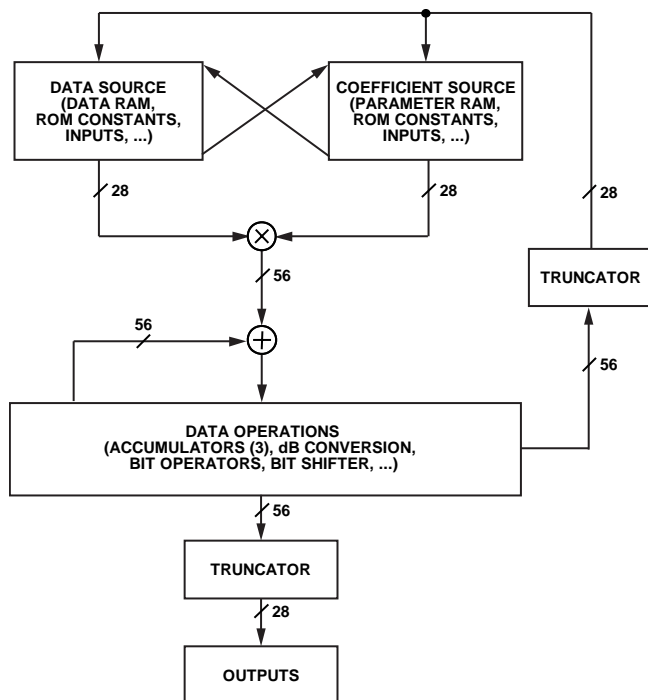

Figure 51. Simplified DSP Core Architecture

08014-200

NUMERIC FORMATS

DSP systems commonly use a standard numeric format. Fractional number systems are specified by an A.B format, where A is the number of bits to the left of the decimal point and B is the number of bits to the right of the decimal point.

The ADAU1781 uses Numerical Format 5.23 for both the parameter and data values.

Numerical Format 5.23

Linear range: -16.0 to $(+16.0 - 1 \text{ LSB})$

Examples:

$1000\ 0000\ 0000\ 0000\ 0000\ 0000\ 0000 = -16.0$
 $1110\ 0000\ 0000\ 0000\ 0000\ 0000\ 0000 = -4.0$
 $1111\ 1000\ 0000\ 0000\ 0000\ 0000\ 0000 = -1.0$
 $1111\ 1110\ 0000\ 0000\ 0000\ 0000\ 0000 = -0.25$
 $1111\ 1111\ 0011\ 0011\ 0011\ 0011\ 0011 = -0.1$
 $1111\ 1111\ 1111\ 1111\ 1111\ 1111\ 1111 = (1 \text{ LSB below } 0)$
 $0000\ 0000\ 0000\ 0000\ 0000\ 0000\ 0000 = 0$
 $0000\ 0000\ 1100\ 1100\ 1100\ 1100\ 1101 = +0.1$
 $0000\ 0010\ 0000\ 0000\ 0000\ 0000\ 0000 = +0.25$
 $0000\ 1000\ 0000\ 0000\ 0000\ 0000\ 0000 = +1.0$
 $0010\ 0000\ 0000\ 0000\ 0000\ 0000\ 0000 = +4.0$
 $0111\ 1111\ 1111\ 1111\ 1111\ 1111\ 1111 = (+16.0 - 1 \text{ LSB})$

The serial port accepts up to 24 bits on the input and is sign-extended to the full 28 bits of the DSP core. This allows internal gains of up to 24 dB without internal clipping.

A digital clipper circuit is used between the output of the DSP core and the DACs or serial port outputs (see Figure 52). This circuit clips the top four bits of the signal to produce a 24-bit output with a range of 1.0 (minus 1 LSB) to -1.0 . Figure 52 shows the maximum signal levels at each point in the data flow in both binary and decibel values.

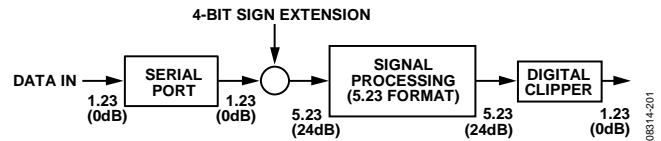

Figure 52. Numeric Precision and Clipping Structure

PROGRAMMING

On power-up, the ADAU1781 must be set with a clocking scheme and then loaded with register settings. After the codec signal path is set up, the DSP core can be programmed. There are 1024 instruction cycles per audio sample, resulting in an internal clock rate of 49.152 MHz when $f_s = 48 \text{ kHz}$. The program RAM contains addresses for 512 instructions, but up to 1024 instructions can be performed by using branching and looping functions.

The part can be programmed easily using SigmaStudio (see Figure 53), a graphical tool provided by Analog Devices. No knowledge of writing line-level DSP code is required. More information about SigmaStudio can be found at www.analog.com.

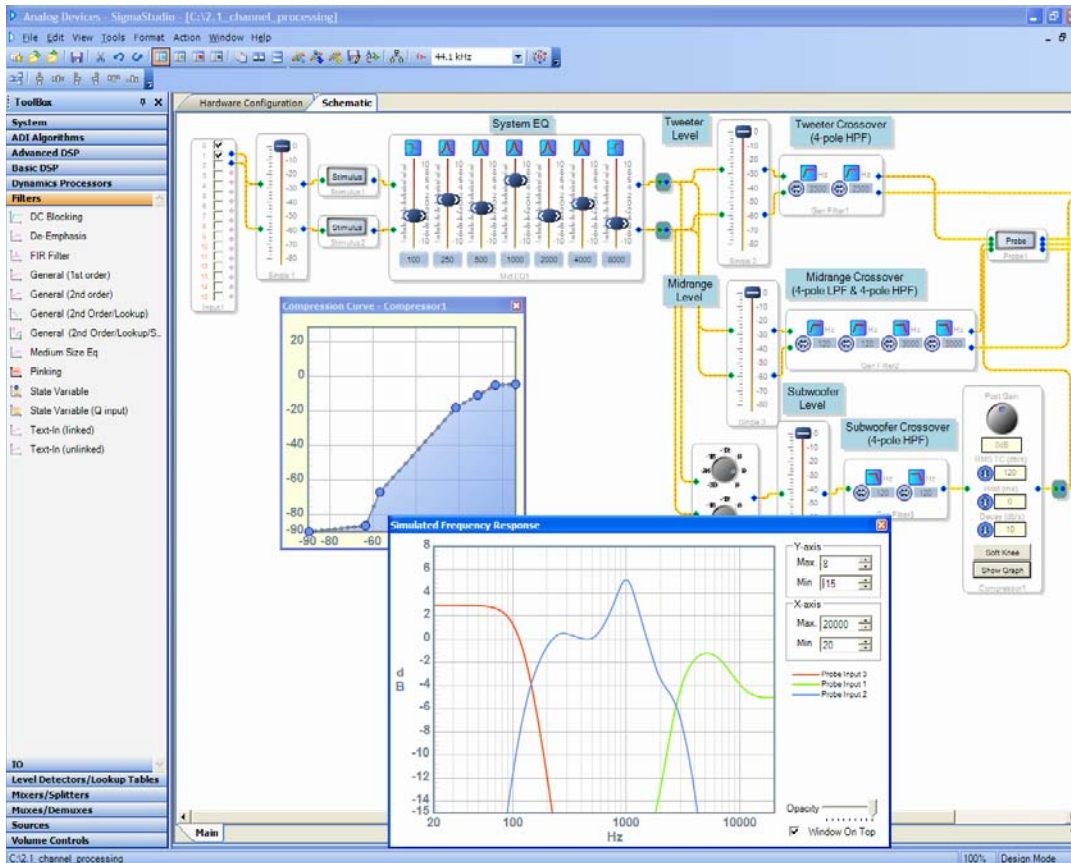

Figure 53. SigmaStudio Screen Shot

PROGRAM RAM, PARAMETER RAM, AND DATA RAM

Table 27. RAM Map and Read/Write Modes

Memory	Size	Address Range	Read	Write	Write Modes
Parameter RAM	512 × 32	0 to 511 (0x0000 to 0x01FF)	Yes	Yes	Direct, safeload
Program RAM	512 × 40	1024 to 1535 (0x0400 to 0x05FF)	Yes	Yes	Direct

Table 27 shows the RAM map (the ADAU1781 register map is provided in the Control Register Map section). The address space encompasses a set of registers and three RAMs: program, parameter, and data. The program RAM and parameter RAM are not initialized on power-up and are in an unknown state until written to.

PROGRAM RAM

The program RAM contains the 40-bit operation codes that are executed by the core. The SigmaStudio compiler calculates maximum instructions per frame for a project and generates an error when the value exceeds the maximum allowable instructions per frame based on the sample rate of the signals in the core.

Because the end of a program contains a jump-to-start command, the unused program RAM space does not need to be filled with no-operation (NOP) commands.

PARAMETER RAM

The parameter RAM is 32 bits wide and occupies Address 0 to Address 511. Each parameter is padded with four 0s before the MSB to extend the 28-bit word to a full 4-byte width. The data format of the parameter RAM is twos complement, 5.23. This means that the coefficients can range from +16.0 (minus 1 LSB) to -16.0, with 1.0 represented by the binary word 0000 1000 0000 0000 0000 0000 0000 or by the hexadecimal word 0x00 0x80 0x00 0x00.

The parameter RAM can be written to directly or with a safe-load write. The direct write mode of operation is typically used during a complete new loading of the RAM using burst mode addressing to avoid any clicks or pops in the outputs. Note that this mode can be used during live program execution, but because there is no handshaking between the core and the control port, the parameter RAM is unavailable to the DSP core during control writes, resulting in clicks and pops in the audio stream.

SigmaStudio automatically assigns the first eight positions to safeload parameters; therefore, project-specific parameters start at Address 0x0008.

DATA RAM

The ADAU1781 data RAM is used to store audio data-words for processing. The user cannot directly address this RAM space, which has a size of 512 words, from the control port.

When implementing blocks, such as delays, that require large amounts of data RAM space, data RAM utilization should be taken into account. The SigmaDSP core processes delay times in one-sample increments; therefore, the total pool of delay available to the user equals 512 multiplied by the sample period. For a $f_{s,DSP}$ of 48 kHz, the pool of available delay is a maximum of about 10 ms, where $f_{s,DSP}$ is the DSP core sampling rate. In practice, this much data memory is not available to the user because every block in a design uses a few data memory locations for its processing. In most DSP programs, this does not significantly affect the total delay time. The SigmaStudio compiler manages the data RAM and indicates whether the number of addresses needed in the design exceeds the maximum number available.

READ/WRITE DATA FORMATS

The read/write formats of the control port are designed to be byte oriented to allow for easy programming of common microcontroller chips. To fit into a byte-oriented format, 0s are appended to the data fields before the MSB to extend the data-word to eight bits. For example, 28-bit words written to the parameter RAM are appended with four leading 0s to equal 32 bits (four bytes); 40-bit words written to the program RAM are not appended with 0s because they are already a full five bytes. These zero-padded data fields are appended to a 3-byte field consisting of a 7-bit chip address, a read/write bit, and a 16-bit RAM/register address. The control port knows how many data bytes to expect based on the address given in the first three bytes.

The total number of bytes for a single-location write command can vary from one byte (for a control register write) to five bytes (for a program RAM write). Burst mode can be used to fill contiguous register or RAM locations. A burst mode write begins by writing the address and data of the first RAM or register location to be written. Rather than ending the control port transaction (by issuing a stop command in I²C mode or by bringing the \overline{CLATCH} signal high in SPI mode after the data-word), as would be done in a single-address write, the next data-word can be written immediately without specifying its address. The ADAU1781 control port auto-increments the address of each write even across the boundaries of the different RAMs and registers. Table 29 and Table 31 show examples of burst mode writes.

Table 28. Parameter RAM Read/Write Format (Single Address)

Byte 0	Byte 1	Byte 2	Byte 3	Bytes[4:6]
CHIP_ADR[6:0], R/W	PARAM_ADR[15:8]	PARAM_ADR[7:0]	0000, PARAM[27:24]	PARAM[23:0]

Table 29. Parameter RAM Block Read/Write Format (Burst Mode)

Byte 0	Byte 1	Byte 2	Byte 3	Bytes[4:6]	Bytes[7:10]	Bytes[11:14]
CHIP_ADR[6:0], R/W	PARAM_ADR[15:8]	PARAM_ADR[7:0]	0000, PARAM[27:24]	PARAM[23:0]		
←—PARAM_ADR—→					PARAM_ADR + 1	PARAM_ADR + 2

Table 30. Program RAM Read/Write Format (Single Address)

Byte 0	Byte 1	Byte 2	Bytes[3:7]
CHIP_ADR[6:0], R/W	PROG_ADR[15:8]	PROG_ADR[7:0]	PROG[39:0]

Table 31. Program RAM Block Read/Write Format (Burst Mode)

Byte 0	Byte 1	Byte 2	Bytes[3:7]	Bytes[8:12]	Bytes[13:17]
CHIP_ADR[6:0], R/W	PROG_ADR[15:8]	PROG_ADR[7:0]	PROG[39:0]		
			PROG_ADR	PROG_ADR + 1	PROG_ADR + 2

SOFTWARE SAFELOAD

To update parameters in real time while avoiding pop and click noises on the output, the ADAU1781 uses a software safeload mechanism. The software safeload mechanism enables the SigmaDSP core to load new parameters into RAM while guaranteeing that the parameters are not in use. This prevents an undesirable condition where an instruction may execute with a mix of old and new parameters.

SigmaStudio sets up the necessary code and parameters automatically for new projects. The safeload code, along with other initialization code, fills the first 39 locations in program RAM. The first eight parameter RAM locations (Address 0x0000 to Address 0x0007) are configured by default in SigmaStudio as described in Table 32.

Table 32. Software Safeload Parameter RAM Defaults

Address (Hex)	Function
0x0000	Modulo RAM size
0x0001	Safeload Data 1
0x0002	Safeload Data 2
0x0003	Safeload Data 3
0x0004	Safeload Data 4
0x0005	Safeload Data 5
0x0006	Safeload target address (offset of -1)
0x0007	Number of words to write/safeload trigger

Address 0x0000, which controls the modulo RAM size, is set by SigmaStudio and is based on the dynamic address generator mode of the project.

Parameter RAM Address 0x0001 to Address 0x0005 are the five data slots for storing the data to be safeloaded. The safeload parameter space contains five data slots by default because most standard signal processing algorithms have five parameters or less.

Address 0x0006 is the target address in parameter RAM (with an offset of -1). This designates the first address to be written. If more than one word is written, the address increments automatically for each data-word. Up to five sequential parameter RAM locations can be updated with safeload during each audio frame. The target address offset of -1 is used because the write address is calculated relative to the address of the data, which starts at Address 0x0001. Therefore, to update a parameter at Address 0x000A, the target address is 0x0009.

Address 0x0007 designates the number of words to be written into the parameter RAM during the safeload. A biquad filter uses all five safeload data addresses. A simple mono gain cell uses only one safeload data address. Writing to this address also triggers the safeload write to occur in the next audio frame.

The safeload mechanism is software based and executes once per audio frame. Therefore, system designers must take care when designing the communication protocol. A delay equal to or greater than the sampling period (the inverse of sampling frequency) is required between each safeload write. A sample rate of 48 kHz equates to a delay of at least 21 μs. If this delay is not observed, the downloaded data is corrupted.

SOFTWARE SLEW

When the values of signal processing parameters are changed abruptly in real time, they sometimes cause pop and click sounds to appear on the audio outputs. To avoid pops and clicks, some algorithms in SigmaStudio implement a software slew functionality. Algorithms using software slew set a target value for a parameter and continuously update the value of that parameter until it reaches the target.

The target value takes an additional space in parameter RAM, and the current value of the parameter is updated in the non-modulo section of data RAM. Assignment of parameters and nonmodulo data RAM is handled by the SigmaStudio compiler and does not need to be programmed manually.

Slew parameters can follow several different curves, including an RC-type curve and a linear curve. These curve types are coded into each algorithm and cannot be modified by the user.

Because algorithms that use software slew generally require more RAM than their nonslew equivalents, they should be used only in situations where a parameter will change during operation of the device.

Figure 54 shows an example of volume slew applied to a sine wave.

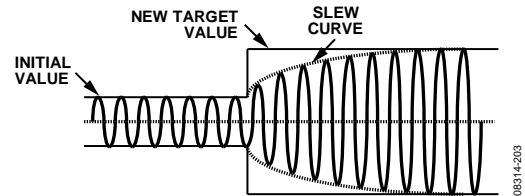

Figure 54. Example of Volume Slew

APPLICATIONS INFORMATION

POWER SUPPLY BYPASS CAPACITORS

Each analog and digital power supply pin should be bypassed to its nearest appropriate ground pin with a single 100 nF capacitor. The connections to each side of the capacitor should be as short as possible, and the trace should stay on a single layer with no vias. For maximum effectiveness, locate the capacitor equidistant from the power and ground pins or, when equidistant placement is not possible, slightly closer to the power pin. Thermal connections to the ground planes should be made on the far side of the capacitor.

Each supply signal on the board should also be bypassed with a single bulk capacitor (10 μ F to 47 μ F).

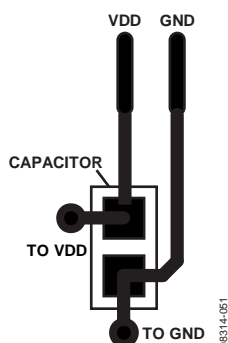

Figure 55. Recommended Power Supply Bypass Capacitor Layout

GSM NOISE FILTER

In mobile applications, excessive 217 Hz GSM noise on the analog supply pins can degrade the quality of the audio signal. To avoid this problem, it is recommended that an LC filter be used in series with the bypass capacitors for the AVDD pins. This filter should consist of a 1.2 nH inductor and a 9.1 pF capacitor in series between AVDDx and ground, as shown in Figure 56.

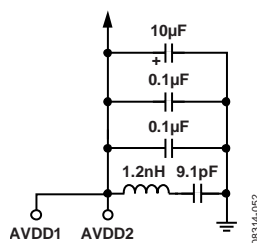

Figure 56. GSM Filter on the Analog Supply Pins

GROUNDING

A single ground plane should be used in the application layout. Components in an analog signal path should be placed away from digital signals.

SPEAKER DRIVER SUPPLY TRACE (AVDD2)

The trace supplying power to the AVDD2 pin has higher current requirements than the AVDD1 pin (up to 300 mA). An appropriately thick trace is recommended.

EXPOSED PAD PCB DESIGN

The ADAU1781 LFCSP package has an exposed pad on the underside. This pad is used to couple the package to the PCB for heat dissipation when using the outputs to drive earpiece or headphone loads. When designing a board for the ADAU1781, special consideration should be given to the following:

- A copper layer equal in size to the exposed pad should be on all layers of the board, from top to bottom, and should connect somewhere to a dedicated copper board layer (see Figure 57).
- Vias should be placed to connect all layers of copper, allowing for efficient heat and energy conductivity. For an example, see Figure 58, which has nine vias arranged in a 3 inch \times 3 inch grid in the pad area.

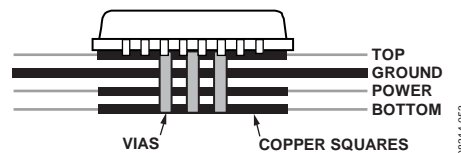

Figure 57. Exposed Pad Layout Example, Side View

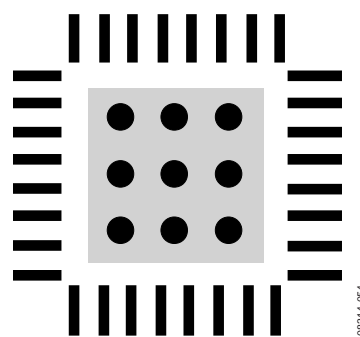

Figure 58. Exposed Pad Layout Example, Top View

CONTROL REGISTER MAP

All registers except the PLL control register are 1-byte write and read registers.

Table 33.

Address		Name
Hex	Decimal	
0x4000	16384	Clock control
0x4001	16385	Regulator control
0x4002	16386	PLL control (48-bit register)
0x4008	16392	Digital microphone and analog beep control
0x4009	16393	Record power management
0x400E	16398	Record gain left PGA
0x400F	16399	Record gain right PGA
0x4010	16400	Microphone bias control and beep enable
0x4015	16405	Serial Port Control 0
0x4016	16406	Serial Port Control 1
0x4017	16407	Converter Control 0
0x4018	16408	Converter Control 1
0x4019	16409	ADC control
0x401A	16410	Left ADC attenuator
0x401B	16411	Right ADC attenuator
0x401C	16412	Playback mixer left control
0x401E	16414	Playback mixer right control
0x401F	16415	Playback mono mixer control
0x4020	16416	Playback clamp amplifier control
0x4025	16421	Left line output mute
0x4026	16422	Right line output mute
0x4027	16423	Playback speaker output control
0x4028	16424	Beep zero-crossing detector control
0x4029	16425	Playback power management
0x402A	16426	DAC control
0x402B	16427	Left DAC attenuator
0x402C	16428	Right DAC attenuator
0x402D	16429	Serial Port Pad Control 0
0x402E	16430	Serial Port Pad Control 1
0x402F	16431	Communication Port Pad Control 0
0x4030	16432	Communication Port Pad Control 1
0x4031	16433	MCKO control
0x4032	16434	Dejitter control
0x4080	16512	Digital Power-Down 0
0x4081	16513	Digital Power-Down 1
0x40C6 to 0x40CA	16582 to 16586	GPIO pin control
0x03E8 to 0x03EC	1000 to 1004	GPIO pin value registers
0x40E9 to 0x40EA	16617 to 16618	Nonmodulo registers
0x40EB	16619	SigmaDSP core frame rate
0x40F2	16626	Serial input route control
0x40F3	16627	Serial output route control
0x40F4	16628	Serial data/GPIO pin configuration
0x40F6	16630	SigmaDSP core run
0x40F8	16632	Serial port sampling rate

CLOCK MANAGEMENT, INTERNAL REGULATOR, AND PLL CONTROL

Register 16384 (0x4000), Clock Control

The clock control register sets the clocking scheme for the ADAU1781. The system clock can be generated from either the PLL or directly from the MCKI (master clock input) pin. Additionally, the MCKO (master clock output) pin can be configured.

Bits[6:5], MCKO Frequency

These bits set the frequency to be output on MCKO as a multiple of the base sampling frequency (32×, 64×, 128×, or 256×). The MCKO pin can be used to provide digital microphones with a clock.

Bit 4, MCKO Enable

This bit enables or disables the MCKO pin.

Bit 3, Clock Source Select

The clock source select bit either routes the MCLK input through the PLL or bypasses the PLL. When using the PLL, the output of

the PLL is always $1024 \times f_s$, and Bits[2:1] should be set to 11. PLL parameters can be set in the PLL control register. Inputs directly from MCKI require an exact clock rate as described in the Bits[2:1], Input Master Clock Frequency section.

Bits[2:1], Input Master Clock Frequency

The maximum clock speed allowed is 1024×48 kHz. These bits set the expected input master clock frequency for proper clock divider values in order to output a constant system clock of $256 \times f_s$. When using the PLL, these bits must always be set to $1024 \times f_s$. When bypassing the PLL, the external clock frequency on the MCKI pin must be $256 \times f_s$, $512 \times f_s$, $768 \times f_s$, or $1024 \times f_s$. Table 35 and Table 36 show the relationship between the system clock and the internal master clock for base sampling frequencies of 44.1 kHz and 48 kHz.

Bit 0, Core Clock Enable

This bit enables the internal master clock to start the IC.

Table 34. Clock Control Register

Bits	Description	Default
7	Reserved	
[6:5]	MCKO frequency 00: $32 \times f_s$ 01: $64 \times f_s$ 10: $128 \times f_s$ 11: $256 \times f_s$	00
4	MCKO enable 0: disabled 1: enabled	0
3	Clock source select 0: direct from MCKI pin 1: PLL clock	0
[2:1]	Input master clock frequency 00: $256 \times f_s$ 01: $512 \times f_s$ 10: $768 \times f_s$ 11: $1024 \times f_s$	00
0	Core clock enable 0: core clock disabled 1: core clock enabled	0

Table 35. Core Clock Output for $f_s = 44.1$ kHz

MCLK Input Setting	MCLK Input Value	MCLK Input Divider	Core Clock
$256 \times f_s$	11.2896 MHz	1	11.2896 MHz
$512 \times f_s$	22.5792 MHz	2	11.2896 MHz
$768 \times f_s$	33.8688 MHz	3	11.2896 MHz
$1024 \times f_s$	45.1584 MHz	4	11.2896 MHz

Table 36. Core Clock Output for $f_s = 48$ kHz

MCLK Input Setting	MCLK Input Value	MCLK Input Divider	Core Clock
$256 \times f_s$	12.288 MHz	1	12.288 MHz
$512 \times f_s$	24.576 MHz	2	12.288 MHz
$768 \times f_s$	36.864 MHz	3	12.288 MHz
$1024 \times f_s$	49.152 MHz	4	12.288 MHz

Register 16385 (0x4001), Regulator Control

Bits[2:1], Regulator Output Level

These bits set the regulated voltage output for the digital core, DVDDOUT. After the initialization sequence has completed, the regulator output is set to 1.4 V. The recommended regulator output level when the device begins to process audio is 1.5 V. Therefore, this register should be set to 1.5 V when the SigmaDSP core is being configured.

Register 16386 (0x4002), PLL Control

This is a 48-bit register that must be written to in a single burst write. PLL operating parameters are used to scale the MCLK input to the desired clock core in order to obtain an appropriate PLL clock (PLL output frequency). The PLL can be configured for either fractional or integer-N type MCLK inputs.

Bits[47:40], Denominator MSB

Byte 1, M[15:8] of the denominator (M) for fractional part of feedback divider. This is concatenated with Denominator LSB, M[7:0].

Bits[39:32], Denominator LSB

Byte 0, M[7:0] of the denominator (M) for fractional part of feedback divider. This is concatenated with Denominator MSB, M[15:8].

Bits[31:24], Numerator MSB

Byte 1, N[15:8] of the numerator (N) for fractional part of the feedback divider. This is concatenated with Numerator LSB, N[7:0].

Bits[23:16], Numerator LSB

Byte 0, N[7:0] of the numerator (N) for fractional part of the feedback divider. This is concatenated with Numerator MSB, N[15:8].

Bits[14:11], Integer

Integer (R) parameter used in both integer-N and fractional PLL operation. This value must be between 2 and 8.

Bits[10:9], Input Divider

The input divider (X) divides the input clock to offer a wider range of input clocks.

Bit 8, PLL Type

This selects the type of PLL operation, fractional or integer-N.

Fractional Type PLL

Fractional type MCLK inputs are scaled to the corresponding desired core clock input using the parameters outlined in Table 39 and Table 40 as examples of typical base sampling frequencies (44.1 kHz and 48 kHz). A numerical-controlled oscillator is used to divide the PLL_CLK by a mixed number given by the addition of the integer part (R) and fractional part (N/M).

For example, if the MCLK is 12 MHz, the required clock is 12.288 MHz, and f_s is 48 kHz, then the PLL clock is 49.152 MHz because PLL clock is always $1024 \times f_s$; therefore,

$$PLL\ Clock/MCLK = 4.096 = 4 + (12/125) = R + (N/M)$$

In this case, the input divider is $X = 1$.

This allows the MCLK input to emulate the desired required clock and output a 49.152 MHz PLL clock. Figure 29 shows how the PLL uses the parameters to emulate the required 12.288 MHz clock.

Integer-N Type PLL

Integer-N type MCLK inputs are any integer multiple of the desired core clock. The fractional part (N/M) is 0; however, the PLL type bit must be set for integer-N.

Bit 1, PLL Lock

The PLL lock bit is a read-only bit. Reading a 1 from this bit indicates that the PLL has locked to the input master clock.

Bit 0, PLL Enable

This bit enables the PLL.

Table 37. Regulator Control Register

Bits	Description	Default
[7:3]	Reserved	
[2:1]	Regulator output level 00: 1.5 V 01: 1.4 V 10: 1.6 V 11: 1.7 V	01
0	Reserved	

Table 38. PLL Control Register

Bits	Description	Default
[47:40]	Denominator MSB 00000000 and 00000000: M[15:8] and M[7:0] = 0 ... 00000000 and 11111101: M[15:8] and M[7:0] = 125 ... 11111111 and 11111111: M[15:8] and M[7:0] = 65,535	00000111
[39:32]	Denominator LSB 00000000 and 00000000: M[15:8] and M[7:0] = 0 ... 00000000 and 11111101: M[15:8] and M[7:0] = 125 ... 11111111 and 11111111: M[15:8] and M[7:0] = 65,535	01010011
[31:24]	Numerator MSB 00000000 and 00000000: N[15:8] and N[7:0] = 0 ... 00000000 and 00001100: N[15:8] and N[7:0] = 12 ... 11111111 and 11111111: N[15:8] and N[7:0] = 65,535	00000010
[23:16]	Numerator LSB 00000000 and 00000000: N[15:8] and N[7:0] = 0 ... 00000000 and 00001100: N[15:8] and N[7:0] = 12 ... 11111111 and 11111111: N[15:8] and N[7:0] = 65,535	10000111
15	Reserved	
[14:11]	Integer 0010: R = 2 0011: R = 3 0100: R = 4 0101: R = 5 0110: R = 6 0111: R = 7 1000: R = 8	0011
[10:9]	Input divider 00: no division 01: divide by X = 2 10: divide by X = 3 11: divide by X = 4	00
8	PLL type 0: integer-N 1: fractional	1
[7:2]	Reserved	
1	PLL lock (read only) 0: unlocked 1: locked (sticky bit)	1
0	PLL enable 0: disabled 1: enabled	1

ADAU1781

Table 39. Fractional PLL Parameter Settings for $f_s = 44.1$ kHz ($f_s = 44.1$ kHz, Core Clock = 256×44.1 kHz, PLL Clock = 45.1584 MHz)

MCLK Input (MHz)	Input Divider (X)	Integer (R)	Denominator (M)	Numerator (N)
12	1	3	625	477
13	1	3	8125	3849
14.4	1	3	125	17
19.2	1	2	125	44
19.68	1	2	2035	302
19.8	1	2	1375	386

Table 40. Fractional PLL Parameter Settings for $f_s = 48$ kHz ($f_s = 48$ kHz, Core Clock = 256×48 kHz, PLL Clock = 49.152 MHz)

MCLK Input (MHz)	Input Divider (X)	Integer (R)	Denominator (M)	Numerator (N)
12	1	4	125	12
13	1	3	1625	1269
14.4	1	3	75	31
19.2	1	2	25	14
19.68	1	2	205	102
19.8	1	2	825	398

RECORD PATH CONFIGURATION

Register 16392 (0x4008), Digital Microphone and Analog Beep Control

This register controls the digital microphone settings and the analog beep input gain.

Bits[5:4], Digital Microphone Enable

These bits control the enable function for the stereo digital microphones. The analog front end is powered down when using a digital microphone.

Bit 3, Beep Input Mute

This bit mutes the beep input.

Bits[2:0], Beep Input Gain

This bit controls the gain setting for the analog beep input; it defaults at 0 dB and can be set as high as 32 dB. The beep signal must be enabled in Register 16400 (0x4010), microphone bias control and beep enable.

Table 41. Digital Microphone and Analog Beep Control Register

Bits	Description	Default
[7:6]	Reserved	
[5:4]	Digital microphone enable 00: disabled 01: MICD1 enabled 10: MICD2 enabled 11: reserved	00
3	Beep input mute 0: muted 1: unmuted	0
[2:0]	Beep input gain. Note that Setting 100 sets the input beep gain to -23 dB. 000: 0 dB 001: +6 dB 010: +10 dB 011: +14 dB 100: -23 dB 101: +20 dB 110: +26 dB 111: +32 dB	000

ADAU1781

Register 16393 (0x4009), Record Power Management

This register manages the power consumption for the record path. In particular, the current distribution for the mixer boosts, ADC, front-end mixer, and PGAs can be set in one of four modes. The four modes of operation available that affect the performance of the device are normal operation, power saving, enhanced performance, and extreme power saving. Normal operation has a base current of 2.5 μA , enhanced performance has a base current of 3 μA , power saving has a base current of 2 μA , and extreme power saving has a base current of 1.5 μA . Enhanced performance offers the highest performance, but with the trade-off of higher power consumption.

Bits[6:5], Mixer Amplifier Boost

These bits set the power mode of operation for the front-end mixer boost. With higher AVDD1 levels, distortion may become an issue affecting performance. Each boost level enhances the THD + N performance at 3.3 V AVDD1.

Bits[4:3], ADC Bias Control

These bits set the bias current for the ADCs based on the mode of operation selected.

Bits[2:1], Front-End Bias Control

These bits set the bias current for the PGAs and mixers in the front-end record path.

Table 42. Record Power Management Register

Bits	Description	Default
7	Reserved	
[6:5]	Mixer amplifier boost 00: normal operation 01: Boost Level 1 10: Boost Level 2 11: Boost Level 3	00
[4:3]	ADC bias control 00: normal operation 01: extreme power saving 10: power saving 11: enhanced performance	00
[2:1]	Front-end bias control 00: normal operation 01: extreme power saving 10: power saving 11: enhanced performance	00
0	Reserved	

Register 16398 (0x400E), Record Gain Left PGA

The record gain left PGA control register controls the left channel input PGA. This register configures the input for either differential or single-ended signals and sets the left channel input recording volume.

Bits[7:5], Left Input Gain

These bits set the left channel analog microphone input PGA gain.

Bit 2, Single-Ended Left Input Enable

If this bit is high (enabled), a single-ended input can be input on the LMIC pin and gained by the PGA. The positive differential

input pin (LMICP) is disabled, and the complementary input of the PGA is switched to common mode.

Bit 1, Record Path Left Mute

This bit mutes the left channel input PGA.

Bit 0, Left PGA Enable

This bit enables the left channel input PGA

Table 43. Record Gain Left PGA Register

Bits	Description	Default
[7:5]	Left input gain 000: 0 dB 001: 6 dB 010: 10 dB 011: 14 dB 100: 17 dB 101: 20 dB 110: 26 dB 111: 32 dB	000
[4:3]	Reserved	
2	Single-ended left input enable 0: disabled 1: enabled	0
1	Record path left mute 0: muted 1: unmuted	0
0	Left PGA enable 0: disabled 1: enabled	0

ADAU1781

Register 16399 (0x400F), Record Gain Right PGA

The record gain right PGA control register controls the right channel input PGA. This register configures the input for either differential or single-ended signals and sets the right channel input recording volume.

Bits[7:5], Right Input Gain

These bits set the right channel analog microphone input PGA gain.

Bit 2, Single-Ended Right Input Enable

If this bit is high (enabled), a single-ended input can be input on the RMIC pin and gained by the PGA. The positive differential

input pin (RMICP) is disabled, and the complementary input of the PGA is switched to common mode.

Bit 1, Record Path Right Mute

This bit mutes the entire right channel input PGA.

Bit 0, Right PGA Enable

This bit enables the right channel PGA.

Table 44. Record Gain Right PGA Register

Bits	Description	Default
[7:5]	Right input gain 000: 0 dB 001: 6 dB 010: 10 dB 011: 14 dB 100: 17 dB 101: 20 dB 110: 26 dB 111: 32 dB	000
[4:3]	Reserved	
2	Single-ended right input enable 0: disabled 1: enabled	0
1	Record path right mute 0: muted 1: unmuted	0
0	Right PGA enable 0: disabled 1: enabled	0

Register 16400 (0x4010), Microphone Bias Control and Beep Enable

Bit 4, Beep Input Enable

This bit enables the beep signal, which is input to the BEEP pin. Setting this bit to 0 mutes the beep signal for all output paths.

Bit 3, Microphone High Performance

This bit puts the microphone bias into high performance mode, by offering more current to the microphone.

Bit 2, Microphone Gain

Provides two voltage bias options, $0.65 \times AVDD1$ and $0.90 \times AVDD1$. A higher bias contributes to a higher microphone gain. The maximum current that can be drawn from MICBIAS is 5 mA.

Bit 0, Microphone Bias Enable

This bit enables the MICBIAS output.

Table 45. Microphone Bias Control and Beep Enable Register

Bits	Description	Default
[7:5]	Reserved	
4	Beep input enable 0: disabled 1: enabled	0
3	Microphone high performance 0: high power 1: low performance	0
2	Microphone gain 0: enabled 1: disabled	0
1	Reserved	
0	Microphone bias enable 0: disabled 1: enabled	0

SERIAL PORT CONFIGURATION

Register 16405 (0x4015), Serial Port Control 0

Bit 5, LRCLK Mode

This bit sets the serial port frame clock (LRCLK) as either a 50% duty cycle waveform or a pulse synchronization waveform. When in slave mode, the pulse should be at least 1 BCLK cycle wide to guarantee proper data transfer.

Bit 4, BCLK Polarity

This bit sets the polarity of the bit clock (BCLK) signal. This setting determines whether the data and frame clock signals change on a rising (+) or falling (–) edge of the BCLK signal (see Figure 59). Standard I²S signals use negative BCLK polarity.

Bit 3, LRCLK Polarity

The polarity of LRCLK determines whether the left stereo channel is initiated on a rising (+) or falling (–) edge of the LRCLK signal (see Figure 60). Standard I²S signals use negative LRCLK polarity.

Bits[2:1], Channels per Frame

These bits set the number of channels contained in the data stream (see Figure 61). The possible choices are stereo (used in standard I²S signals), TDM 4 (a 4-channel time division multiplexed stream), or TDM 8 (an 8-channel time division multiplexed stream). The TDM output modes are simply multichannel data streams, and the data pin does not become high impedance during periods when it is not outputting data.

Within a TDM stream, channels are grouped by pair, as shown in Figure 62.

Bit 0, Serial Data Port Mode

This bit sets the clock pins as either master or slave. Both LRCLK and BCLK are the bus master of the serial port when master mode is enabled.

Table 46. Serial Port Control 0 Register

Bits	Description	Default
[7:6]	Reserved	
5	LRCLK mode 0: 50% duty cycle clock 1: pulse mode; pulse should be at least 1 BCLK wide	0
4	BCLK polarity 0: data changes on falling (–) edge 1: data changes on rising (+) edge	0
3	LRCLK polarity 0: left frame starts on falling (–) edge 1: left frame starts on rising (+) edge	0
[2:1]	Channels per frame 00: stereo (two channels) 01: TDM 4 (four channels) 10: TDM 8 (eight channels) 11: reserved	00
0	Serial data port mode 0: slave 1: master	0

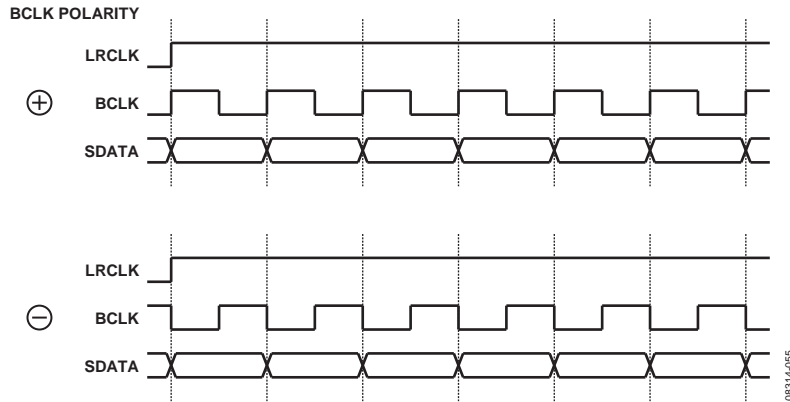

Figure 59. Serial Port BCLK Polarity

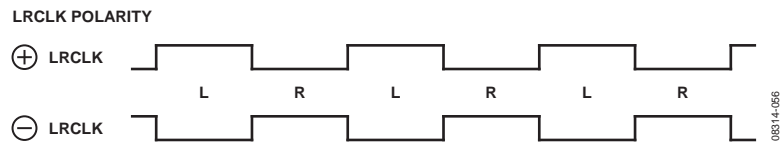

Figure 60. Serial Port LRCLK Polarity

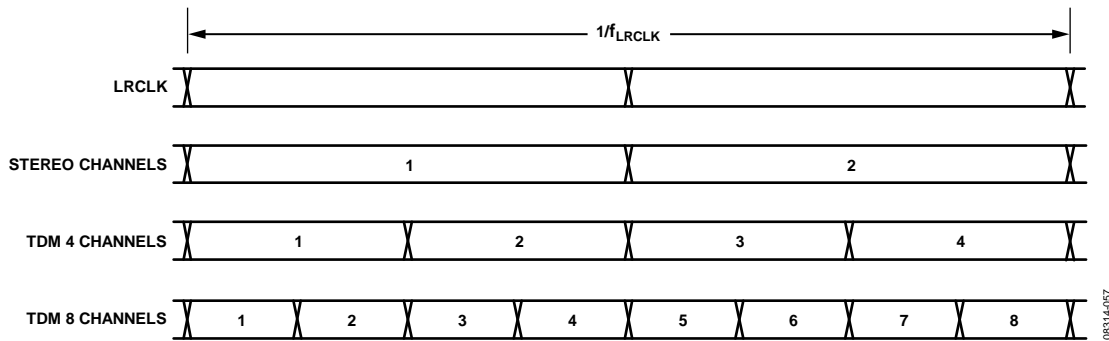

Figure 61. Channels per Frame

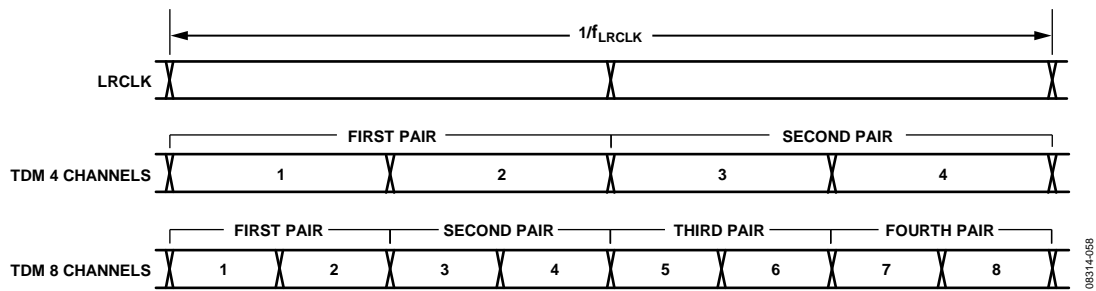

Figure 62. TDM Channel Pairs

Register 16406 (0x4016), Serial Port Control 1

Bits[7:5], Number of Bit Clock Cycles per Frame

These bits set the number of BCLK cycles contained in one LRCLK period. The frequency of BCLK is calculated as the number of bit clock cycles per frame times the sample rate of the serial port in hertz. Figure 63 and Figure 64 show examples of different settings for these bits.

Bit 4, ADC Channel Position in TDM

This register sets the order of the ADC channels when output on the serial output port. A setting of 0 puts the left channel first in its respective TDM channel pair. A setting of 1 puts the right channel first in its respective TDM channel pair. This bit should be set in conjunction with Register 16408 (0x4018), Converter Control 1, Bits[1:0], on-chip ADC data selection in TDM mode, to select where the data should appear in the TDM stream. Figure 65 shows a setting of 0, and Figure 66 shows a setting of 1.

Bit 3, DAC Channel Position in TDM

This register sets the order of the DAC channels when output on the serial output port. A setting of 0 puts the left channel first in its respective TDM channel pair. A setting of 1 puts the right channel first in its respective TDM channel pair. This bit should be set in conjunction with Register 16407 (0x4017), Converter Control 0, Bits[6:5], on-chip DAC data selection in TDM mode, to select where the data should appear in the TDM stream. Figure 65 shows a setting of 0, and Figure 66 shows a setting of 1.

Bit 2, MSB Position

This bit sets the bit-level endianness (or bit order) of the data stream. A setting of 0 results in a big-endian order, with the MSB coming first in the stream and the LSB coming last. A setting of 1 results in a little-endian order, with the LSB coming first in the stream and the MSB coming last. Figure 67 shows examples of the two settings with a 24-bit audio stream in an MSB delay-by-0 configuration. In Figure 67, M stands for MSB, and L stands for LSB.

Bits[1:0], Data Delay from LRCLK Edge

These bits set the delay between the LRCLK edge and the first data bit in the stream. The I²S standard is a delay of one BCLK cycle. Examples of different data delay settings are shown in Figure 68, with a 64 BCLK cycle per frame, 24-bit audio data, big-endian bit order configuration. In Figure 68, M represents the most significant bit of the audio channel's data, and L represents the least significant bit.

The first example setting (delay by 0) in Figure 68 represents a left-justified mode because the least significant bit aligns with the beginning of the audio frame. The third example setting (delay by 8) represents a right-justified mode because the least significant bit aligns with the end of the audio frame. A delay-by-16 setting would not be valid in this mode because the audio data would exceed the boundaries of the frame clock period.

Figure 69 shows an example of delay by 16 for a 16-bit audio stream with 64 BCLK cycles per frame.

Table 47. Serial Port Control 1 Register

Bits	Description	Default
[7:5]	Number of bit clock cycles per frame 000: 64 001: 32 010: 48 011: 128 100: 256 101: reserved 110: reserved 111: reserved	000
4	ADC channel position in TDM 0: left first 1: right first	0
3	DAC channel position in TDM 0: left first 1: right first	0
2	MSB position 0: MSB first 1: MSB last	0
[1:0]	Data delay from LRCLK edge 00: 1 BCLK cycle 01: 0 BCLK cycles 10: 8 BCLK cycles 11: 16 BCLK cycles	00

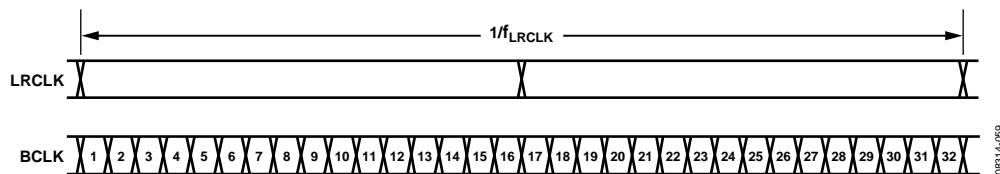

Figure 63. Example: 32 BCLK Cycles per Frame

08314-069

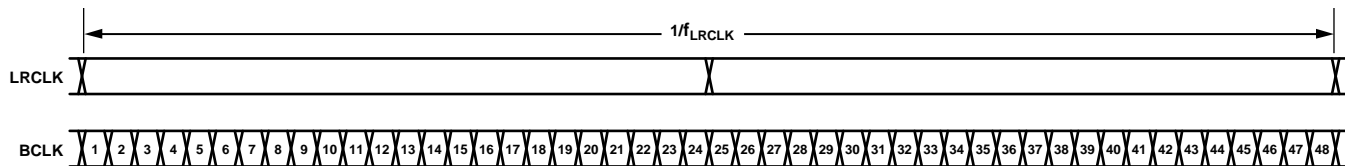

Figure 64. Example: 48 BCLK Cycles per Frame

08314-060

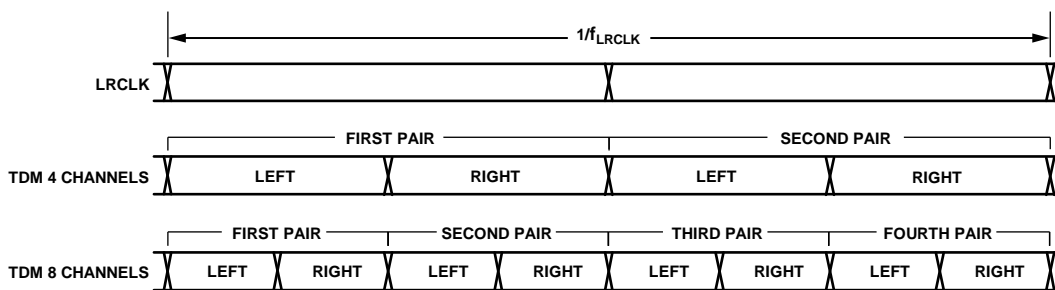

Figure 65. Left First Channel Selection in TDM

08314-061

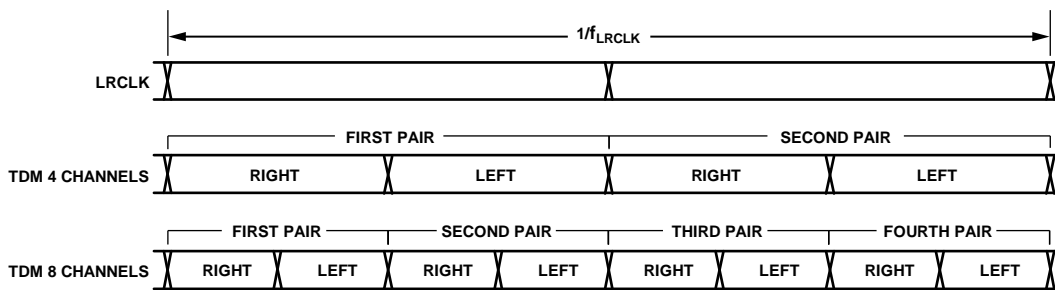

Figure 66. Right First Channel Selection in TDM

08314-062

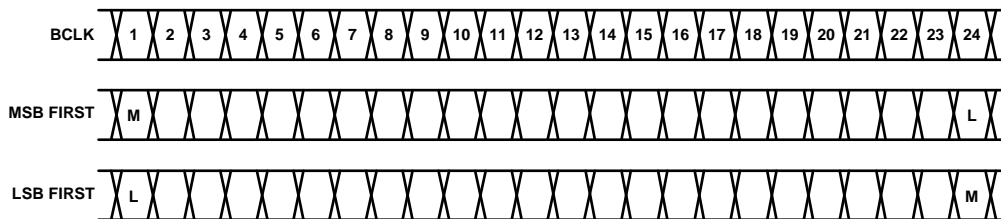

Figure 67. MSB Position Settings

08314-063

ADAU1781

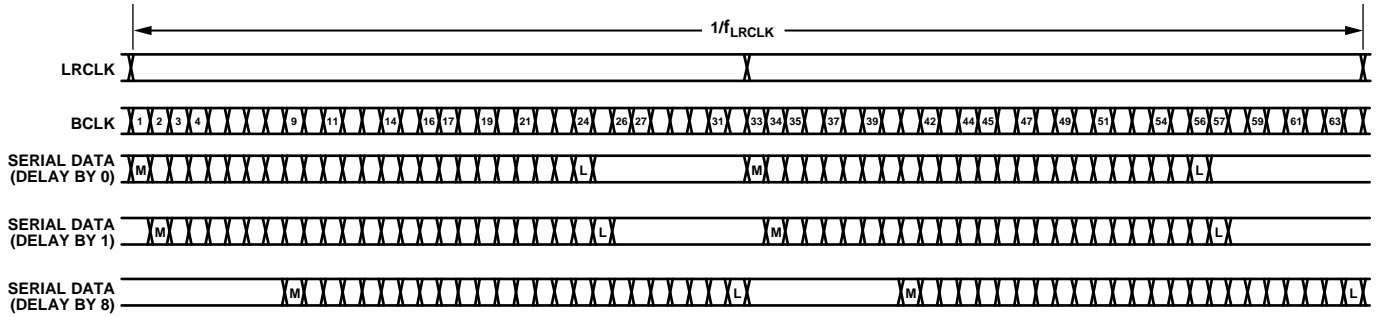

Figure 68. Serial Audio Data Delay Example Settings

08314-064

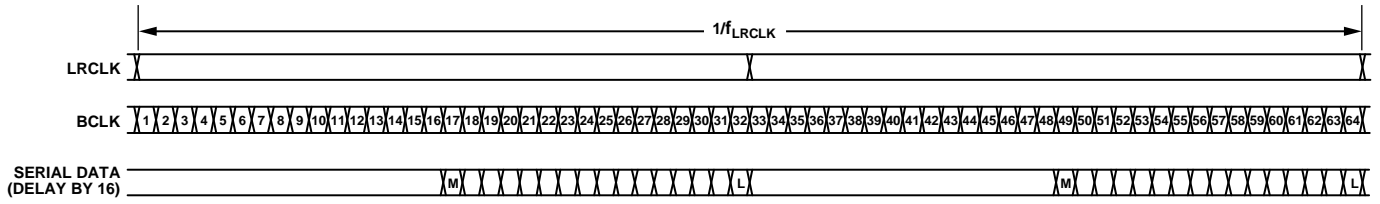

Figure 69. Serial Audio Data Delay by 16 Example

08314-065

AUDIO CONVERTER CONFIGURATION

Register 16407 (0x4017), Converter Control 0

Bits[6:5], On-Chip DAC Data Selection in TDM Mode

These bits set the position of the DAC input channels on a TDM stream. In TDM 4 mode, valid settings are first pair or second pair. In TDM 8 mode, valid settings are first pair, second pair, third pair, or fourth pair. These bits should be set in conjunction with Register 16406 (0x4016), Serial Port Control 1, Bit 3, DAC channel position in TDM, to select where the data should appear in the TDM stream.

Figure 70, Figure 71, and Figure 72 show examples of different TDM settings.

Bit 4, DAC Oversampling Ratio

This bit sets the oversampling ratio of the DAC relative to the audio sample rate. The higher rate yields slightly better audio quality but increases power consumption.

Bit 3, ADC Oversampling Ratio

This bit sets the oversampling ratio of the ADC relative to the audio sample rate. The higher rate yields slightly better audio quality but increases power consumption.

Bits[2:0], Converter Sampling Rate

These bits set the sampling rate of the audio ADCs and DACs relative to the SigmaDSP core's audio sample rate.

Table 48. Converter Control 0 Register

Bits	Description	Default
7	Reserved	
[6:5]	On-chip DAC data selection in TDM mode 00: first pair 01: second pair 10: third pair 11: fourth pair	00
4	DAC oversampling ratio 0: 128 1: 64	0
3	ADC oversampling ratio 0: 128 1: 64	0
[2:0]	Converter sampling rate; the numbers in parentheses are example values for a base sample rate of 48 kHz 000: f_s (48 kHz) 001: $f_s/6$ (8 kHz) 010: $f_s/4$ (12 kHz) 011: $f_s/3$ (16 kHz) 100: $f_s/2$ (24 kHz) 101: $f_s/1.5$ (32 kHz) 110: $f_s \times 2$ (96 kHz) 111: reserved	000

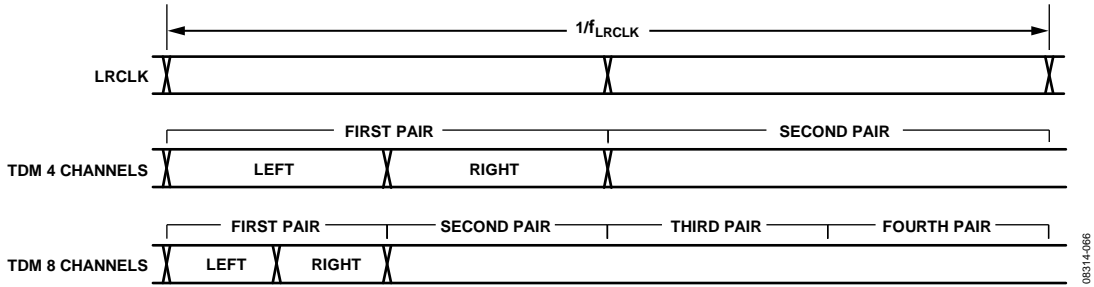

Figure 70. Example of Left Channel First, First Pair TDM Setting

08314-066

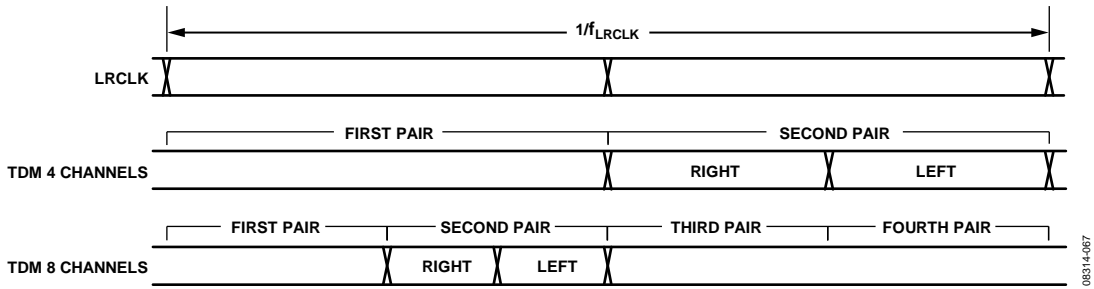

Figure 71. Example of Right Channel First, Second Pair TDM Setting

08314-067

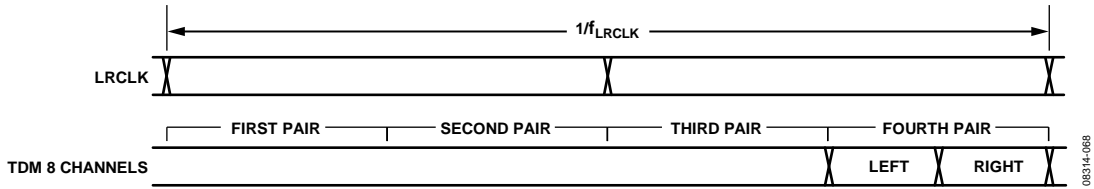

Figure 72. Example of Left Channel First, Fourth Pair TDM Setting

08314-068

Register 16408 (0x4018), Converter Control 1
Bits[1:0], On-Chip ADC Data Selection in TDM Mode

These bits set the position of the ADC output channels on a TDM stream. In TDM 4 mode, valid settings are first pair or second pair. In TDM 8 mode, valid settings are first pair, second pair, third pair, or fourth pair. These bits should be set in conjunction

with Register 16406 (0x4016), Serial Port Control 1, Bit 4, ADC channel position in TDM, to select where the data should appear in the TDM stream.

Figure 70, Figure 71, and Figure 72 show examples of different TDM settings.

Table 49. Converter Control 1 Register

Bits	Description	Default
[7:2]	Reserved	
[1:0]	On-chip ADC data selection in TDM mode 00: first pair 01: second pair 10: third pair 11: fourth pair	00

ADAU1781

Register 16409 (0x4019), ADC Control

Bit 6, Invert Input Polarity

This bit enables an optional polarity inverter in the ADC path, which is an amplifier with a gain of -1 , representing a 180° phase shift.

Bit 5, High-Pass Filter Select

This bit enables an optional high-pass filter in the ADC path, with a cutoff frequency of 2 Hz when $f_s = 48$ kHz. The cutoff frequency scales linearly with f_s .

Bit 4, Digital Microphone Data Polarity Swap

This bit inverts the polarity of valid data states for the digital microphone data stream. A typical PDM microphone can drive its data output pin either high or low, not both. This bit must be configured accordingly to recognize a valid output state of the microphone. The default is negative, meaning that a digital logic low signal is recognized by the ADAU1781 as a pulse in the PDM signal.

Bit 3, Digital Microphone Channel Swap

This bit allows the left and right channels of the digital microphone input to swap. Standard mode is the left channel on the rising edge and the right channel on the falling edge. Swapped mode is the right channel on the rising edge and the left channel on the falling edge.

Bit 2, Digital Microphone Input Select

This bit must be enabled to use the digital microphone inputs. When this bit is asserted, the on-chip ADCs are off, BCLK is the master at $128 \times f_s$, and ADC_SDATA is expected to have the left and right channels interleaved. This bit must be disabled to use the ADCs.

Bits[1:0], ADC Enable

These bits must be configured to use the ADCs. ADC channels can be enabled or disabled individually.

Table 50. ADC Control Register

Bits	Description	Default
7	Reserved	
6	Invert input polarity 0: normal 1: inverted	0
5	High-pass filter select 0: disabled 1: enabled	0
4	Digital microphone data polarity swap 0: negative 1: positive	0
3	Digital microphone channel swap 0: standard mode 1: swapped mode	0
2	Digital microphone input select 0: digital microphone input off 1: select digital microphone input, ADCs off	0
[1:0]	ADC enable 00: both off 01: left on 10: right on 11: both on	00

Register 16410 (0x401A), Left ADC Attenuator

Bits[7:0], Left ADC Digital Attenuator

These bits control a 256-step, logarithmically spaced volume control from 0 dB to -95.625 dB, in increments of 0.375 dB. When a new value is entered into this register, the volume control slews gradually to the new value, avoiding pops and clicks in the process. The slew ramp is logarithmic, incrementing 0.375 dB per audio frame.

Register 16411 (0x401B), Right ADC Attenuator

Bits[7:0], Right ADC Digital Attenuator

These bits control a 256-step, logarithmically spaced volume control from 0 dB to -95.625 dB, in increments of 0.375 dB. When a new value is entered into this register, the volume control slews gradually to the new value, avoiding pops and clicks in the process. The slew ramp is logarithmic, incrementing 0.375 dB per audio frame.

Table 51. Left ADC Attenuator Register

Bits	Description	Default
[7:0]	Left ADC digital attenuator; attenuation is in increments of 0.375 dB with each step of slewing 00000000: 0 dB 00000001: -0.375 dB 00000010: -0.75 dB ... 11111110: -95.25 dB 11111111: -95.625 dB	00000000

Table 52. Right ADC Attenuator Register

Bits	Description	Default
[7:0]	Right ADC digital attenuator; attenuation is in increments of 0.375 dB with each step of slewing 00000000: 0 dB 00000001: -0.375 dB 00000010: -0.75 dB ... 11111110: -95.25 dB 11111111: -95.625 dB	00000000

PLAYBACK PATH CONFIGURATION

Register 16412 (0x401C), Playback Mixer Left Control

Bit 5, Left DAC Mute

This bit mutes the left DAC output. It does not have any slew and is updated immediately when the register write has been completed. This results in an abrupt cutoff of the audio output and should therefore be preceded by a soft mute in the SigmaDSP core or a slew mute using the DAC attenuator.

Bits[4:1], Left Playback Beep Gain

These bits set the gain of the beep signal in the left playback path. If the zero-crossing detector is activated, the change in gain is applied on the next detected zero crossing or when the timeout period expires, whichever comes first. The gain control is in 3 dB increments and should not be incremented more than 3 dB at a time in order to avoid audible artifacts on the output.

Register 16414 (0x401E), Playback Mixer Right Control

Bit 6, Right DAC Mute

This bit mutes the right DAC output. It does not have any slew and is updated immediately when the register write has been completed. This results in an abrupt cutoff of the audio output and should therefore be preceded by a soft mute in the SigmaDSP core or a slew mute using the DAC attenuator.

Bits[4:1], Right Playback Beep Gain

These bits set the gain of the beep signal in the right playback path. If the zero-crossing detector is activated, the change in gain is applied on the next detected zero crossing or when the timeout period expires, whichever comes first. The gain control is in 3 dB increments and should not be incremented more than 3 dB at a time in order to avoid audible artifacts on the output.

Table 53. Playback Mixer Left Control Register

Bits	Description	Default
[7:6]	Reserved	
5	Left DAC mute 0: muted 1: unmuted	0
[4:1]	Left playback beep gain 0000: muted 0001: -15 dB 0010: -12 dB 0011: -9 dB 0100: -6 dB 0101: -3 dB 0110: 0 dB 0111: +3 dB 1000: +6 dB	0000
0	Reserved	

Table 54. Playback Mixer Right Control Register

Bits	Description	Default
7	Reserved	
6	Right DAC mute 0: muted 1: unmuted	0
5	Reserved	
[4:1]	Right playback beep gain 0000: muted 0001: -15 dB ... 1000: +6 dB	0000
0	Reserved	

Register 16415 (0x401F), Playback Mono Mixer Control

Bit 7, Left DAC Mute

This bit mutes the left DAC output, but does not power down the DAC. Use of this bit does not result in power savings.

Bit 6, Right DAC Mute

This bit mutes the right DAC output, but does not power down the DAC. Use of this bit does not result in power savings.

Bits[5:2], Mono Playback Beep Gain

These bits set the gain of the beep output signal in mono mode. If the zero-crossing detector is active, then the gain change takes place on the next zero crossing in the beep signal or when the timeout occurs, whichever comes first.

Bit 0, Mono Output Mute

This bit mutes the mono line output.

Register 16416 (0x4020), Playback Clamp Amp Control

The playback clamp amp is an amplifier on the line output path. If the line outputs are muted using Register 16421 (0x4025), left line output mute, or Register 16422 (0x4026), right line output mute, this amplifier serves to maintain a common-mode voltage on the line output pins. This helps to avoid a pop or click when the line outputs are reenabled.

Bit 1, Clamp Amplifier Power Saving Mode

The clamp amplifier has two operating modes: high power mode and low power mode. The high power mode has more current available to maintain a stable common-mode voltage on the output pins. The low power mode may be slightly less stable, depending on operating conditions, but saves several microamps.

Bit 0, Clamp Amplifier Control

This bit enables or disables the clamp amp. It is enabled by default. The clamp amp should usually be enabled in systems where the line outputs are used.

Table 55. Playback Mono Mixer Control Register

Bits	Description	Default
7	Left DAC mute 0: muted 1: unmuted	0
6	Right DAC mute 0: muted 1: unmuted	0
[5:2]	Mono playback beep gain 0000: muted 0001: -15 dB 0010: -12 dB 0011: -9 dB 0100: -6 dB 0101: -3 dB 0110: 0 dB 0111: +3 dB 1000: +6 dB	0000
1	Reserved	
0	Mono output mute (active low) 0: muted 1: unmuted	0

Table 56. Playback Clamp Amplifier Control Register

Bits	Description	Default
[7:2]	Reserved	
1	Clamp amplifier power saving mode 0: high power 1: low power	1
0	Clamp amplifier control 0: enabled 1: disabled	0

ADAU1781

Register 16421 (0x4025), Left Line Output Mute Bit 1, Left Line Output Mute

This bit mutes the left line output. It does not have any effect on the speaker outputs.

Register 16422 (0x4026), Right Line Output Mute Bit 1, Right Line Output Mute

This bit mutes the right line output. It does not have any effect on the speaker outputs.

Table 57. Left Line Output Mute Register

Bits	Description	Default
[7:2]	Reserved	
1	Left line output mute (active low) 0: muted 1: unmuted	0
0	Reserved	

Table 58. Right Line Output Mute Register

Bits	Description	Default
[7:2]	Reserved	
1	Right line output mute (active low) 0: muted 1: unmuted	0
0	Reserved	

Register 16423 (0x4027), Playback Speaker Output Control

Bits[7:6], Speaker Output Gain Control

These bits control the gain of the speaker output. In general, this parameter should be tuned at a system level, set once during system initialization and not altered during operation of the system.

Bit 0, Speaker Output Enable

This bit enables the speaker output. It initiates the speaker power-up and power-down sequences shown in Figure 35 and Figure 36.

Register 16424 (0x4028), Beep Zero-Crossing Detector Control

Bits[4:3], Detector Timeout

The timeout detector waits the specified amount of time for a beep zero crossing before forcing the mute or unmute in the playback path beep gains (that is, the left playback beep gain, right playback beep gain, and mono playback beep gain).

Bit 0, Zero-Crossing Detector Enable

This bit enables the zero-crossing detector. Disabling the beep zero-crossing detector may cause clicks and pops on the output when using the beep path.

Table 59. Playback Speaker Output Control Register

Bits	Description	Default
[7:6]	Speaker output gain control 00: 0 dB 01: 2 dB 10: 4 dB 11: 6 dB	00
[5:1]	Reserved	
0	Speaker output enable 0: disabled 1: enabled	0

Table 60. Beep Zero-Crossing Detector Control Register

Bits	Description	Default
[7:5]	Reserved	
[4:3]	Detector timeout 00: 20 ms 01: 10 ms 10: 5 ms 11: 2.5 ms	11
[2:1]	Reserved	
0	Zero-crossing detector enable 0: disabled 1: enabled	1

ADAU1781

Register 16425 (0x4029), Playback Power Management

This register controls the unity current supplied to each functional block described. Within the functional blocks, the current can be multiplied. Normal operation has a base current of 2.5 μ A, enhanced performance has a base current of 3 μ A, power saving has a base current of 2 μ A, and extreme power saving has a base current of 1.5 μ A. Enhanced performance mode offers the best audio quality but also uses the most current.

Bit [7:6], Speaker Amplifier Bias Control

These bits control the amount of unity bias current allotted to the speaker amplifier.

Bits[5:4], DAC Bias Control

These bits control the amount of unity bias current allotted to the DAC.

Bits[3:2], Back-End Bias Control

These bits control the amount of unity bias current allotted to the playback mixers and amplifiers.

Bit 1, Back-End Right Enable

This bit enables the playback mixers and amplifiers.

Bit 0, Back-End Left Enable

This bit enables the playback mixers and amplifiers.

Table 61. Playback Power Management Register

Bits	Description	Default
[7:6]	Speaker amplifier bias control 00: normal operation 01: power saving 10: enhanced performance 00: reserved	00
[5:4]	DAC bias control 00: normal operation 01: extreme power saving 10: power saving 00: enhanced performance	00
[3:2]	Back-end bias control 00: normal operation 01: extreme power saving 10: power saving 00: enhanced performance	00
1	Back-end right enable 0: disabled 1: enabled	0
0	Back-end left enable 0: disabled 1: enabled	0

Register 16426 (0x402A), DAC Control

Bits[7:6], Mono Mode

These bits control the output mode of the DAC. Setting these bits to 00 outputs two distinct channels, left and right. Setting these bits to 01 outputs the left input channel on both the left and right outputs, and the right input channel is lost. Setting these bits to 10 outputs the right input channel on both the left and right outputs, and the left input channel is lost. Setting these bits to 11 mixes the left and right input channels and outputs the mixed mono signal on both the left and right outputs.

Bit 5, Invert Input Polarity

This bit applies a gain of -1, or a 180° phase shift, to the DAC output signal.

Bit 2, DAC De-Emphasis Filter Enable

This bit enables a de-emphasis filter and should be used when a preemphasized signal is input to the DACs.

Bits[1:0], DAC Enable

These bits allow the DACs to be individually enabled or disabled. Disabling unused DACs can result in significant power savings.

Table 62. DAC Control Register

Bits	Description	Default
[7:6]	Mono mode 00: stereo output 01: both output left channel 10: both output right channel 11: both output left/right mix	00
5	Invert input polarity 0: normal 1: inverted	0
[4:3]	Reserved	
2	DAC de-emphasis filter enable 0: disabled 1: enabled	0
[1:0]	DAC enable 00: both off 01: left on 10: right on 11: both on	00

ADAU1781

Register 16427 (0x402B), Left DAC Attenuator

Bits[7:0], Left DAC Digital Attenuator

These bits control a 256-step, logarithmically spaced volume control from 0 dB to -95.625 dB, in increments of 0.375 dB. When a new value is entered into this register, the volume control slews gradually to the new value, avoiding pops and clicks in the process. The slew ramp is logarithmic, incrementing 0.375 dB per audio frame.

Register 16428 (0x402C), Right DAC Attenuator

Bits[7:0], Right DAC Digital Attenuator

These bits control a 256-step, logarithmically spaced volume control from 0 dB to -95.625 dB, in increments of 0.375 dB. When a new value is entered into this register, the volume control slews gradually to the new value, avoiding pops and clicks in the process. The slew ramp is logarithmic, incrementing 0.375 dB per audio frame.

Table 63. Left DAC Attenuator Register

Bits	Description	Default
[7:0]	Left DAC digital attenuator, in increments of 0.375 dB with each step of slewing 00000000: 0 dB 00000001: -0.375 dB 00000010: -0.75 dB ... 11111110: -95.25 11111111: -95.625 dB	00000000

Table 64. Right DAC Attenuator Register

Bits	Description	Default
[7:0]	Right DAC digital attenuator, in increments of 0.375 dB with each step of slewing 00000000: 0 dB 00000001: -0.375 dB 00000010: -0.75 dB ... 11111110: -95.25 11111111: -95.625 dB	00000000

PAD CONFIGURATION

Figure 73 shows a block diagram of the pad design for the GPIO/serial port and communications port pins.

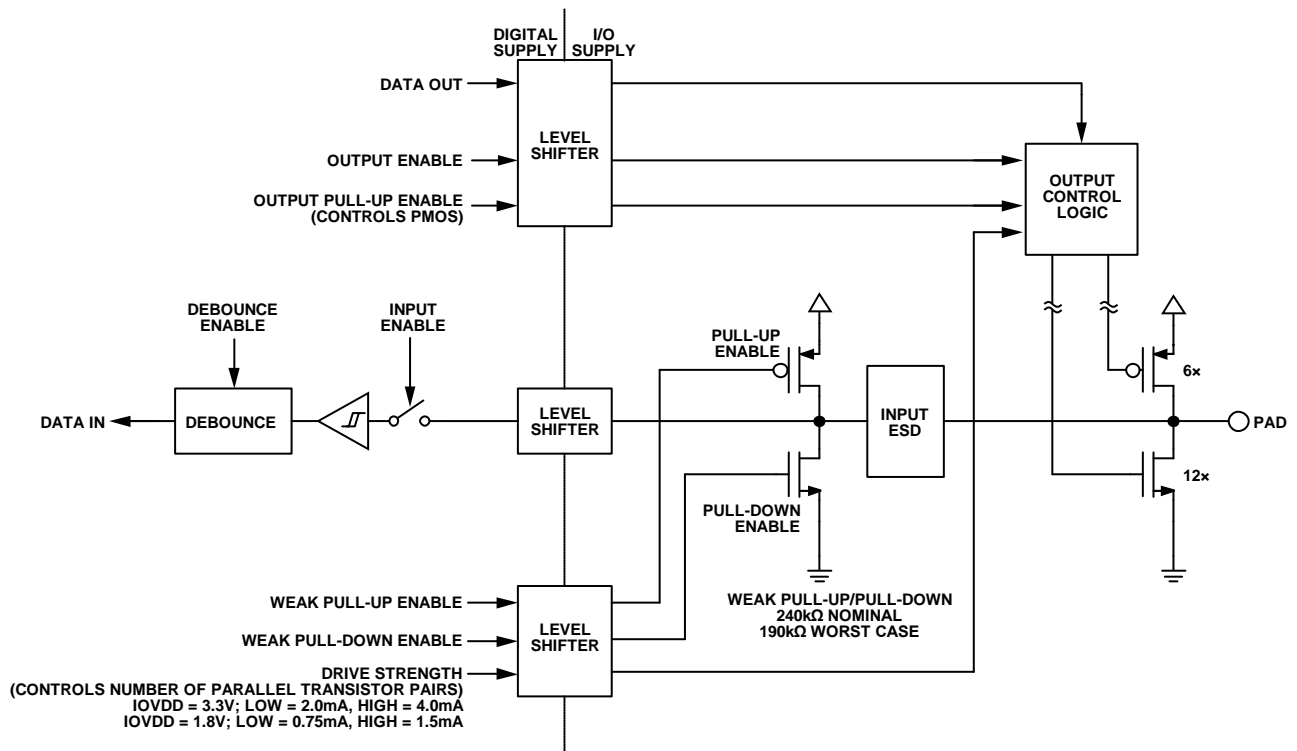

Figure 73. Pad Configuration, Internal Design

08314-089

ADAU1781

Register 16429 (0x402D), Serial Port Pad Control 0

Bits[7:6], ADC_SDATA Pad Pull-Up/Pull-Down

These bits enable or disable a weak pull-up or pull-down device on the pad. The effective resistance of the pull-up or pull-down is nominally 240 kΩ.

Bits[5:4], DAC_SDATA Pad Pull-Up/Pull-Down

These bits enable or disable a weak pull-up or pull-down device on the pad. The effective resistance of the pull-up or pull-down is nominally 240 kΩ.

Bits[3:2], LRCLK Pad Pull-Up/Pull-Down

These bits enable or disable a weak pull-up or pull-down device on the pad. The effective resistance of the pull-up or pull-down is nominally 240 kΩ.

Bits[1:0], BCLK Pad Pull-Up/Pull-Down

These bits enable or disable a weak pull-up or pull-down device on the pad. The effective resistance of the pull-up or pull-down is nominally 240 kΩ.

Table 65. Serial Port Pad Control 0 Register

Bits	Description	Default
[7:6]	ADC_SDATA pad pull-up/pull-down 00: pull-up 01: reserved 10: none (default) 11: pull-down	11
[5:4]	DAC_SDATA pad pull-up/pull-down 00: pull-up 01: reserved 10: none (default) 11: pull-down	11
[3:2]	LRCLK pad pull-up/pull-down 00: pull-up 01: reserved 10: none (default) 11: pull-down	11
[1:0]	BCLK pad pull-up/pull-down 00: pull-up 01: reserved 10: none (default) 11: pull-down	11

Register 16430 (0x402E), Serial Port Pad Control 1

Bit 3, ADC_SDATA Pin Drive Strength

This bit sets the drive strength of the ADC_SDATA pin. Low mode yields 2 mA when IOVDD = 3.3 V, or 0.75 mA when IOVDD = 1.8 V. High mode yields 4 mA when IOVDD = 3.3 V, or 1.5 mA when IOVDD = 1.8 V.

Bit 2, DAC_SDATA Pin Drive Strength

This bit sets the drive strength of the DAC_SDATA pin. Low mode yields 2 mA when IOVDD = 3.3 V, or 0.75 mA when IOVDD = 1.8 V. High mode yields 4 mA when IOVDD = 3.3 V, or 1.5 mA when IOVDD = 1.8 V.

Bit 1, LRCLK Pin Drive Strength

This bit sets the drive strength of the LRCLK pin. Low mode yields 2 mA when IOVDD = 3.3 V, or 0.75 mA when IOVDD = 1.8 V. High mode yields 4 mA when IOVDD = 3.3 V, or 1.5 mA when IOVDD = 1.8 V.

Bit 0, BCLK Pin Drive Strength

This bit sets the drive strength of the BCLK pin. Low mode yields 2 mA when IOVDD = 3.3 V, or 0.75 mA when IOVDD = 1.8 V. High mode yields 4 mA when IOVDD = 3.3 V, or 1.5 mA when IOVDD = 1.8 V.

Table 66. Serial Port Pad Control 1 Register

Bits	Description	Default
[7:4]	Reserved	
3	ADC_SDATA pin drive strength 0: low 1: high	0
2	DAC_SDATA pin drive strength 0: low 1: high	0
1	LRCLK pin drive strength 0: low 1: high	0
0	BCLK pin drive strength 0: low 1: high	0

ADAU1781

Register 16431 (0x402F), Communication Port Pad Control 0

Bits[7:6], CDATA Pad Pull-Up/Pull-Down

These bits enable or disable a weak pull-up or pull-down device on the pad. The effective resistance of the pull-up or pull-down is nominally 240 kΩ.

Bits[5:4], CLATCH Pad Pull-Up/Pull-Down

These bits enable or disable a weak pull-up or pull-down device on the pad. The effective resistance of the pull-up or pull-down is nominally 240 kΩ.

Bits[3:2], SCL/CCLK Pad Pull-Up/Pull-Down

These bits enable or disable a weak pull-up or pull-down device on the pad. The effective resistance of the pull-up or pull-down is nominally 240 kΩ.

Bits[1:0], SDA/COOUT Pad Pull-Up/Pull-Down

These bits enable or disable a weak pull-up or pull-down device on the pad. The effective resistance of the pull-up or pull-down is nominally 240 kΩ.

Table 67. Communication Port Pad Control 0 Register

Bits	Description	Default
[7:6]	CDATA pad pull-up/pull-down 00: pull-up 01: reserved 10: none (default) 11: pull-down	11
[5:4]	CLATCH pad pull-up/pull-down 00: pull-up 01: reserved 10: none (default) 11: pull-down	00
[3:2]	SCL/CCLK pad pull-up/pull-down 00: pull-up 01: reserved 10: none (default) 11: pull-down	11
[1:0]	SDA/COOUT pad pull-up/pull-down 00: pull-up 01: reserved 10: none (default) 11: pull-down	11

Register 16432 (0x4030), Communication Port Pad Control 1

Bit 3, CDATA Pin Drive Strength

This bit sets the drive strength of the CDATA pin. Low mode yields 2 mA when IOVDD = 3.3 V, or 0.75 mA when IOVDD = 1.8 V. High mode yields 4 mA when IOVDD = 3.3 V, or 1.5 mA when IOVDD = 1.8 V.

Bit 2, CLATCH Pin Drive Strength

This bit sets the drive strength of the CLATCH pin. Low mode yields 2 mA when IOVDD = 3.3 V, or 0.75 mA when IOVDD = 1.8 V. High mode yields 4 mA when IOVDD = 3.3 V, or 1.5 mA when IOVDD = 1.8 V.

Bit 1, SCL/CCLK Pin Drive Strength

This bit sets the drive strength of the SCL/CCLK pin. Low mode yields 2 mA when IOVDD = 3.3 V, or 0.75 mA when IOVDD = 1.8 V. High mode yields 4 mA when IOVDD = 3.3 V, or 1.5 mA when IOVDD = 1.8 V.

Bit 0, SDA/COUT Pin Drive Strength

This bit sets the drive strength of the SDA/COUT pin. Low mode yields 2 mA when IOVDD = 3.3 V, or 0.75 mA when IOVDD = 1.8 V. High mode yields 4 mA when IOVDD = 3.3 V, or 1.5 mA when IOVDD = 1.8 V.

Table 68. Communication Port Pad Control 1 Register

Bits	Description	Default
[7:4]	Reserved	
3	CDATA pin drive strength 0: low 1: high	0
2	CLATCH pin drive strength 0: low 1: high	0
1	SCL/CCLK pin drive strength 0: low 1: high	0
0	SDA/COUT pin drive strength 0: low 1: high	0

ADAU1781

Register 16433 (0x4031), MCKO Control

Bit 2, MCKO Pin Drive Strength

This bit sets the drive strength of the MCKO pin. Low mode yields 2 mA when IOVDD = 3.3 V, or 0.75 mA when IOVDD = 1.8 V. High mode yields 4 mA when IOVDD = 3.3 V, or 1.5 mA when IOVDD = 1.8 V.

Bit 1, MCKO Pull-Up Enable

This bit enables or disables a weak pull-up device on the pad. The effective resistance of the pull-up is nominally 240 kΩ.

Bit 0, MCKO Pull-Down Enable

This bit enables or disables a weak pull-down device on the pad. The effective resistance of the pull-down is nominally 240 kΩ.

Table 69. MCKO Control Register

Bits	Description	Default
[7:3]	Reserved	
2	MCKO pin drive strength 0: low 1: high	0
1	MCKO pull-up enable (active low) 0: pull-down disabled 1: pull-down enabled	0
0	MCKO pull-down enable 0: pull-down disabled 1: pull-down enabled	1

Register 16434 (0x4032), Dejitter Control

Bits[7:0], Dejitter Window Size

The dejitter control register not only allows the size of the dejitter window to be set, but also allows all dejitter circuits in the device to be activated or bypassed. Dejitter circuits protect against duplicate samples or skipped samples due to jitter from the serial ports in slave mode. Disabling and reenabling certain subsystems in the device—that is, the ADCs, serial ports, sound engine/DSP core, and DACs—during operation can cause the associated dejitter circuits to fail. As a result, audio data fails to be output to the next subsystem in the device.

When the serial ports are in master mode, the dejitter circuit can be bypassed by setting the dejitter window to 0. When the serial ports are in slave mode, the dejitter circuit can be reinitialized prior to outputting audio from the device, guaranteeing that audio is output to the next subsystem in the device. Any time audio needs to pass through the ADCs, serial port, sound engine/DSP core, or DACs, the dejitter circuit can be bypassed and reset by setting the dejitter window size to 0. Then, the dejitter circuit can be immediately reactivated, without a wait period, by setting the dejitter window size to the default value of 5.

Table 70. Dejitter Control Register

Bits	Description	Default
[7:0]	Dejitter window size 00000000: 0 core clock cycles 00000101: 5 core clock cycles	00000101

DIGITAL SUBSYSTEM CONFIGURATION

Register 16512 (0x4080), Digital Power-Down 0

Bit 7, ADC Engine

Setting this bit to 0 disables the ADCs and the digital microphone inputs.

Bit 6, Memory Controller

Setting this bit to 0 disables all memory access, which disables the SigmaDSP core, ADCs, and DACs, as well as prohibits memory access via the control port.

Bit 5, Clock Domain Transfer

Setting this bit to 0—in conjunction with Bit 4, serial ports—disables the serial ports.

Bit 4, Serial Ports

Setting this bit to 0—in conjunction with Bit 5, clock domain transfer—disables the serial ports.

Bit 3, Serial Output Routing

Setting this bit to 0 disables the routing paths for the record signal path, which goes from the SigmaDSP core to the serial port output.

Bit 2, Serial Input Routing

Setting this bit to 0 disables the routing paths for the playback signal path, which goes from the serial input ports to the SigmaDSP core.

Bit 1, Serial Port, ADC, DAC, and Frame Pulse Clock Generator

Setting this bit to 0 disables the internal clock generator, which generates all master clocks for the serial ports, SigmaDSP core, ADCs, and DACs. This bit must be enabled if audio is being passed through the ADAU1781.

Bit 0, SigmaDSP Core

Setting this bit to 0 disables the SigmaDSP core and makes the memory inaccessible. This bit must be enabled in order to process audio and change parameter values.

Table 71. Digital Power-Down 0 Register

Bit	Description	Default
7	ADC engine 0: disabled 1: enabled	0
6	Memory controller 0: disabled 1: enabled	0
5	Clock domain transfer (when using the serial ports) 0: disabled 1: enabled	0
4	Serial ports 0: disabled 1: enabled	0
3	Serial output routing 0: disabled 1: enabled	0
2	Serial input routing 0: disabled 1: enabled	0
1	Serial port, ADC, DAC, and frame pulse clock generator 0: disabled 1: enabled	0
0	SigmaDSP core 0: disabled 1: enabled	0

Register 16513 (0x4081), Digital Power-Down 1

Bit 3, Output Precharge

The output precharge system allows the outputs to be biased before they are enabled and prevents pops or clicks from appearing on the output. This bit should be set to 1 at all times.

Bit 2, Zero-Crossing Detector

Setting this bit to 0 disables the zero-crossing detector for beep playback.

Bit 1, Digital Microphone

Setting this bit to 0 disables the digital microphone input.

Bit 0, DAC Engine

Setting this bit to 0 disables the DACs.

Table 72. Digital Power-Down 1 Register

Bits	Description	Default
[7:4]	Reserved	
3	Output precharge 0: disabled 1: enabled	1
2	Zero-crossing detector 0: disabled 1: enabled	1
1	Digital microphone 0: disabled 1: enabled	0
0	DAC engine 0: disabled 1: enabled	0

ADAU1781

Register 16582 to Register 16586 (0x40C6 to 0x40CA), GPIO Pin Control

Bits[3:0], GPIO Pin Function

The GPIO pin control register sets the functionality of each GPIO pin as depicted in Table 74. GPIO0 to GPIO3 use the same pins as the serial port and must be enabled in Register 16628 (0x40F4), serial data/GPIO pin configuration. Pin 7 is a dedicated GPIO.

The GPIO pin can be set directly by the SigmaDSP core and therefore should be set as 1011 or 1100 (outputs set by the

SigmaDSP core). In order for GPIO0 through GPIO3 to be used, they should be configured as 1001 or 1010 (outputs set by the I²C/SPI port).

There are five GPIO pin value registers that allow the input/output data value of the GPIO pin to be written to or read directly from the control port. The corresponding addresses are listed in Table 75. Each value register contains four bytes and can store only one of two values: logic high or logic low. Logic high is stored as 0x00, 0x80, 0x00, 0x00. Logic low is stored as 0x00, 0x00, 0x00, 0x00.

Table 73. GPIO Pin Control Registers

Address		Register	Bits	Description	Default
Decimal	Hex				
16582	0x40C6	GPIO pin control	[7:4] [3:0]	Reserved Dedicated GPIO (Pin 7) function (see Table 74)	1100
16583	0x40C7	GPIO0 control	[7:4] [3:0]	Reserved GPIO0 pin function (see Table 74)	1100
16584	0x40C8	GPIO1 control	[7:4] [3:0]	Reserved GPIO1 pin function (see Table 74)	1100
16585	0x40C9	GPIO2 control	[7:4] [3:0]	Reserved GPIO2 pin function (see Table 74)	1100
16586	0x40CA	GPIO3 control	[7:4] [3:0]	Reserved GPIO3 pin function (see Table 74)	1100

Table 74. GPIO Pin Functions

GPIO Bits[3:0]	GPIO Pin Function
0000	Input without debounce
0001	Input with debounce (0.3 ms)
0010	Input with debounce (0.6 ms)
0011	Input with debounce (0.9 ms)
0100	Input with debounce (5 ms)
0101	Input with debounce (10 ms)
0110	Input with debounce (20 ms)
0111	Input with debounce (40 ms)
1000	Input controlled by I ² C/SPI port
1001	Output set by I ² C/SPI port with pull-up
1010	Output set by I ² C/SPI port without pull-up
1011	Output set by SigmaDSP core with pull-up
1100	Output set by SigmaDSP core without pull-up
1101	Reserved
1110	Output CRC error (sticky)
1111	Output watchdog error (sticky)

Register 1000 to Register 1004 (0x03E8 to 0x03EC), GPIO Pin Value

Table 75. Addresses of GPIO Pin Value Registers

Address		Register
Decimal	Hex	
1000	0x03E8	GPIO pin value, GPIO
1001	0x03E9	GPIO pin value, GPIO0
1002	0x03EA	GPIO pin value, GPIO1
1003	0x03EB	GPIO pin value, GPIO2
1004	0x03EC	GPIO pin value, GPIO3

Register 16617 and Register 16618 (0x40E9 and 0x40EA), Nonmodulo

These registers set the boundary for the nonmodulo RAM space used by the SigmaDSP core. An appropriate value is automatically loaded to this register during initialization. It should not be modified for any reason.

Register 16619 (0x40EB), SigmaDSP Core Frame Rate Bits[3:0], SigmaDSP Core Frame Rate

These bits set the frequency of the frame start pulse, which is delivered to the SigmaDSP core to begin processing on each audio frame. It effectively determines the sample rate of audio in the SigmaDSP core. This register should always be set to none at least one frame prior to disabling Register 16630 (0x40F6), SigmaDSP core run, Bit 0, SigmaDSP core run, to allow the SigmaDSP core to finish processing the current frame before halting.

Table 76. Nonmodulo Registers

Bits	Description
[31:0]	Reserved

Table 77. SigmaDSP Core Frame Rate Register

Bits	Description	Default
[7:4]	Reserved	
[3:0]	SigmaDSP core frame rate 0000: $f_s \times 2$ (96 kHz) 0001: f_s (48 kHz) 0010: $f_s/1.5$ (32 kHz) 0011: $f_s/2$ (24 kHz) 0100: $f_s/3$ (16 kHz) 0101: $f_s/4$ (12 kHz) 0110: $f_s/6$ (8 kHz) 0111: serial data input rate 1000: serial data output rate 1001: $f_s \times 4$ (192 kHz) 1010: none ... 1111: none	0000

ADAU1781

Register 16626 (0x40F2), Serial Input Route Control

Bits[3:0], Input Routing

These bits select which serial data input channels are routed to the DACs (see Figure 74).

Table 78. Serial Input Route Control Register

Bits	Description	Default
[7:4]	Reserved	
[3:0]	Input routing 0000: serial input to SigmaDSP core to DACs 0001: serial input [L0, R0] ¹ to DACs [L, R] 0010: reserved 0011: serial input [L1, R1] ¹ to DACs [L, R] 0100: reserved 0101: serial input [L2, R2] ¹ to DACs [L, R] 0110: reserved 0111: serial input [L3, R3] ¹ to DACs [L, R] 1000: reserved 1001: serial input [R0, L0] ¹ to DACs [L, R] 1010: reserved 1011: serial input [R1, L1] ¹ to DACs [L, R] 1100: reserved 1101: serial input [R2, L2] ¹ to DACs [L, R] 1110: reserved 1111: serial input [R3, L3] ¹ to DACs [L, R]	0000

¹ Lx = left side of Channel x; Rx = right side of Channel x.

Register 16627 (0x40F3), Serial Output Route Control

Bits[3:0], Output Routing

These bits select where the ADC outputs are routed in the serial data stream (see Figure 74).

Table 79. Serial Output Route Control Register

Bits	Description	Default
[7:4]	Reserved	
[3:0]	Output routing 0000: ADCs to SigmaDSP core to serial outputs 0001: ADCs [L, R] to serial output [L0, R0] ¹ 0010: reserved 0011: ADCs [L, R] to serial output [L1, R1] ¹ 0100: reserved 0101: ADCs [L, R] to serial output [L2, R2] ¹ 0110: reserved 0111: ADCs [L, R] to serial output [L3, R3] ¹ 1000: reserved 1001: ADCs [L, R] to serial output [R0, L0] ¹ 1010: reserved 1011: ADCs [L, R] to serial output [R1, L1] ¹ 1100: reserved 1101: ADCs [L, R] to serial output [R2, L2] ¹ 1110: reserved 1111: ADCs [L, R] to serial output [R3, L3] ¹	0000

¹ Lx = left side of Channel x; Rx = right side of Channel x.

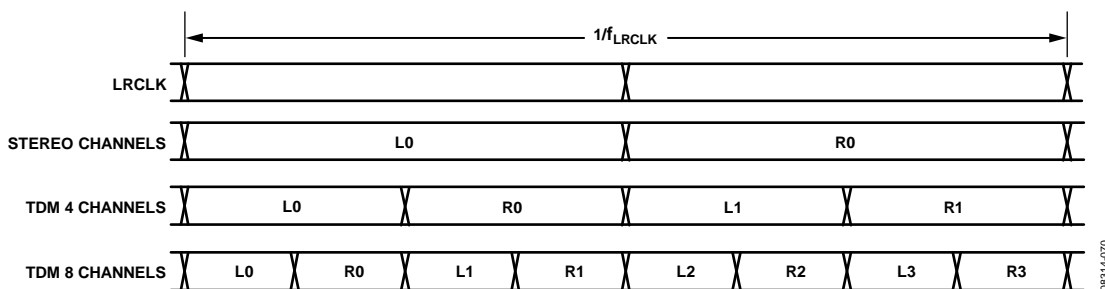

Figure 74. Serial Port Routing Control

Register 16628 (0x40F4), Serial Data/GPIO Pin Configuration

Bits[3:0], GPIO[0:3]

The serial data/GPIO pin configuration register controls the functionality of the serial data port pins. If the bits in this register are set to 1, then the GPIO[0:3] pins become GPIO interfaces to the SigmaDSP core. If these bits are set to 0, they remain LRCLK, BCLK, or serial port data pins, respectively.

Register 16630 (0x40F6), SigmaDSP Core Run

Bit 0, SigmaDSP Core Run

This bit, in conjunction with the SigmaDSP core frame rate, initiates audio processing in the SigmaDSP core. When this bit is enabled, the program counter begins to increment when a new frame of audio data is input to the SigmaDSP core. When this bit is disabled, the SigmaDSP core goes into standby mode.

Before going into standby mode, the following sequence must be performed:

1. Set the SigmaDSP core frame rate in Register 16619 to 0x7F (none).
2. Wait 3 ms.
3. Set the SigmaDSP core run bit in Register 16630 to 0x00.

When reenabling the SigmaDSP core run bit, the following sequence must be followed:

1. Set the SigmaDSP core frame rate in Register 16619 to an appropriate value.
2. Set the SigmaDSP core run bit in Register 16630 to 0x01.

Register 16632 (0x40F8), Serial Port Sampling Rate

Bits[2:0], Serial Port Control Sampling Rate

These bits set the serial port sampling rate as a function of the audio sampling rate, f_s . In most applications, the serial port sampling rate, SigmaDSP core sampling rate, and ADC and DAC sampling rates should be equal.

Table 80. Serial Data/GPIO Pin Configuration Register

Bits	Description	Default
[7:4]	Reserved	
3	GPIO0 0: LRCLK 1: GPIO enabled	0
2	GPIO1 0: BCLK 1: GPIO enabled	0
1	GPIO2 0: serial data output 1: GPIO enabled	0
0	GPIO3 0: serial data input 1: GPIO enabled	0

Table 81. SigmaDSP Core Run Register

Bits	Description	Default
[7:1]	Reserved	
0	SigmaDSP core run 0: SigmaDSP core standby 1: run the SigmaDSP core	0

Table 82. Serial Port Sampling Rate Register

Bits	Description	Default
[7:3]	Reserved	
[2:0]	Serial port control sampling rate 000: $f_s/1$ (48 kHz) 001: $f_s/6$ (8 kHz) 010: $f_s/4$ (12 kHz) 011: $f_s/3$ (16 kHz) 100: $f_s/2$ (24 kHz) 101: $f_s/1.5$ (32 kHz) 110: $f_s/0.5$ (96 kHz) 111: reserved	000

OUTLINE DIMENSIONS

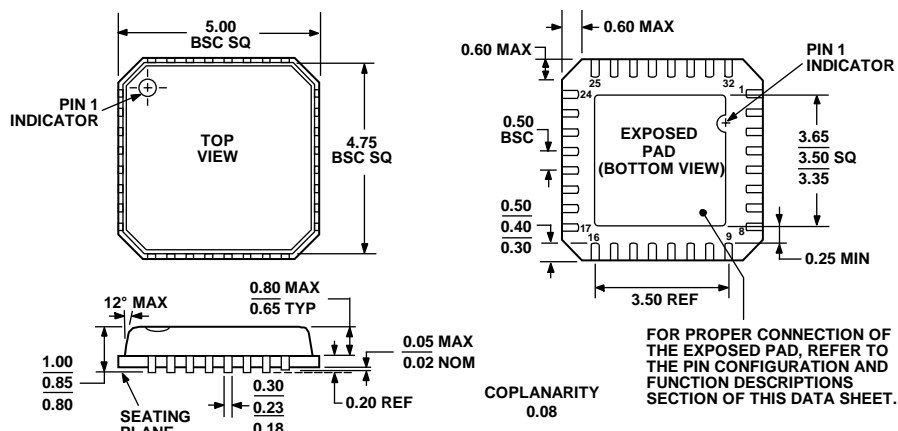

COMPLIANT TO JEDEC STANDARDS MO-220-VHHD-2
 Figure 75. 32-Lead Lead Frame Chip Scale Package [LFCSP_VQ]
 5 mm × 5 mm Body, Very Thin Quad
 (CP-32-4)
 Dimensions shown in millimeters

100608-A

ORDERING GUIDE

Model ¹	Temperature Range	Package Description	Package Option
ADAU1781BCPZ	-25°C to +85°C	32-Lead LFCSP_VQ	CP-32-4
ADAU1781BCPZ-RL7	-25°C to +85°C	32-Lead LFCSP_VQ, 7" Tape and Reel	CP-32-4
EVAL-ADAU1781Z		Evaluation Board	

¹ Z = RoHS Compliant Part.

ADAU1781

NOTES

NOTES

ADAU1781

NOTES

Purchase of licensed I²C components of Analog Devices or one of its sublicensed Associated Companies conveys a license for the purchaser under the Philips I²C Patent Rights to use these components in an I²C system, provided that the system conforms to the I²C Standard Specification as defined by Philips.

©2009–2011 Analog Devices, Inc. All rights reserved. Trademarks and registered trademarks are the property of their respective owners.
D08314-0-1/11(B)



www.analog.com