

## TPA3245 Evaluation Module

This user's guide describes the operation of the evaluation module ( TPA3245EVM, rev. B) for the TPA3245 100-W Stereo/200-W mono PurePath™ Ultra-HD Analog Input Power Stage. The user's guide also provides design information, which includes schematic, BOM, and PCB layout. For questions and support, go to the E2E forums ([e2e.ti.com](http://e2e.ti.com)).

The main contents of this document are:

- Hardware descriptions and implementation
- Design information

Related documents:

- TPA3245 data sheet ([SLASEC7](#))

### Contents

1	Hardware Overview.....	3
1.1	TPA3245EVM Features.....	3
1.2	TPA3245EVM Frequency Adjust .....	4
1.3	TPA3245EVM Single-Ended and Differential Input .....	4
1.4	TPA3245EVM Clip Overtemperature and Fault Indicators .....	5
2	TPA3245EVM Setup .....	6
2.1	TPA3245EVM Setup .....	6
2.2	Hardware Requirements .....	6
2.3	Hardware Default Setup BTL (2.0) .....	7
3	Using the TPA3245EVM in Different Output Configurations .....	8
3.1	BTL Plus Two SE (2.1) Operation .....	8
3.2	PBTL (0.1) Output Operation .....	10
3.3	Single-Ended (SE) Output (4.0) Operation .....	11
4	Optional Inductors .....	12
5	Board Layouts, Bill of Materials, and Schematic .....	13
5.1	TPA3245EVM Board Layouts .....	13
5.2	TPA3245EVM Board Dimension .....	15
5.3	Bill of Materials .....	16
5.4	TPA3245EVM Schematic .....	19

### List of Figures

1	TPA3245EVM .....	3
2	TPA3245EVM Connections .....	6
3	TPA3245EVM THD + N vs Output Power 30 V, BTL 4 Ω, 600 kHz .....	12
4	TPA3245EVM Top Composite Assembly .....	13
5	TPA3245EVM Bottom Composite Assembly .....	14
6	TPA3245EVM Board Dimension .....	15
7	TPA3245EVM Schematic 1 .....	19
8	TPA3245EVM Schematic 2 .....	20
9	TPA3245EVM Schematic 3 .....	21

---

**List of Tables**

1	Frequency Adjust Master Mode Selection.....	4
2	Fault and Clip Overtemperature Status.....	5
3	Mode Selection Pins .....	8
4	SE + 1 BTL Default Jumper States.....	8
5	PBTL Default Jumper States .....	10
6	SE 4.0 Default Jumper States .....	11
7	Bill of Materials .....	16

## 1 Hardware Overview

The TPA3245EVM PurePath™ Ultra-HD evaluation module demonstrates the TPA3245DDV integrated circuit from Texas Instruments. The TPA3245DDV is a high-performance, high-power, class-D amplifier that enables true premium sound quality with high-efficiency class-D technology. It features an advanced integrated feedback design and high-speed gate driver error correction (PurePath Ultra-HD), which enables ultra-low distortion across the audio band and superior audio quality. This EVM supports two BTL (stereo 2.0) output channels, one PBTL (mono 0.1) output channel, one BTL plus two SE (2.1) output channels, and four SE (4.0) output channel configurations. The NE5532 is a high-performance audio op amp designed to allow TPA3245DDV operation with differential or single-ended input signals to the EVM with differential inputs yielding the optimal performance. The TPA3245EVM is a complete  $2\text{-}V_{\text{RMS}}$  analog input  $2 \times 100\text{-W}$  stereo/ $1 \times 200\text{-W}$  mono high-power amplifier ready for evaluation and excellent listening experience.

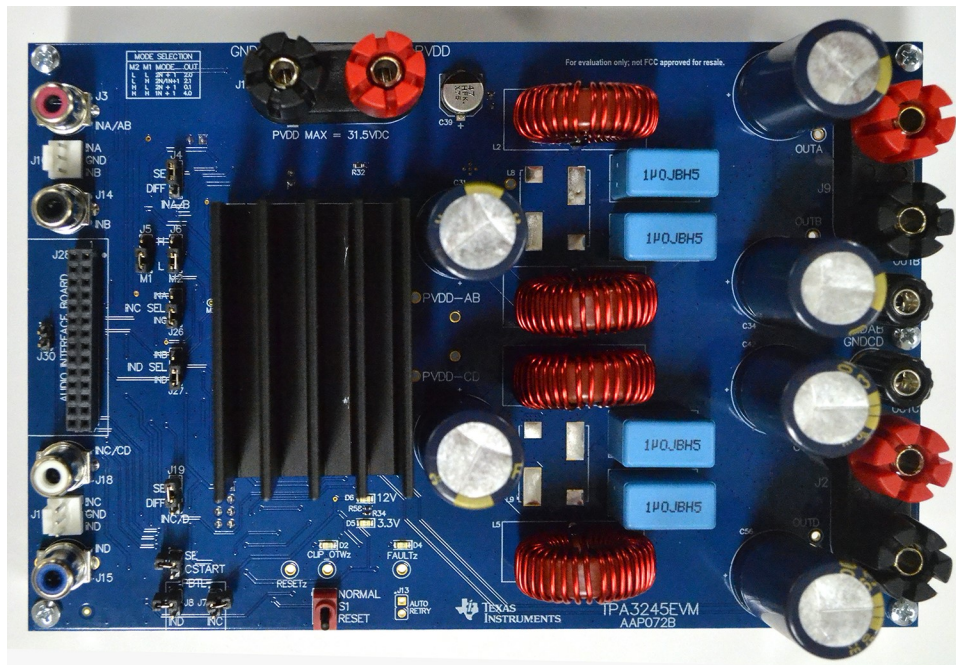

**Figure 1. TPA3245EVM**

### 1.1 TPA3245EVM Features

The TPA3245EVM has following features:

- Stereo PurePath Ultra-HD evaluation module
- Self-contained protection system (short circuit, clip, and thermal)
- Standard  $4\text{-}V_{\text{RMS}}$  differential input or  $2\text{-}V$  single-ended line input
- BTL, PBTL, and SE output configuration support
- Frequency adjust and oscillator sync interface
- Single supply voltage range 14–31.5 V
- Double-sided, plated-through, 2-oz Cu, 2-layer PCB layout

## 1.2 TPA3245EVM Frequency Adjust

The TPA3245EVM offers hardware trimmed oscillator frequency by external control of the `FREQ_ADJ` pin. The *Frequency* adjust can be used to reduce interference problems while using a radio receiver tuned within the AM band, the switching frequency can be changed from nominal to lower values. These values should be chosen such that the nominal and the lower value switching frequencies together results in the fewest cases of interference throughout the AM band. The oscillator frequency can be selected by the value of the `FREQ_ADJ` resistor connected to GND in master mode according to [Table 1](#).

**Table 1. Frequency Adjust Master Mode Selection**

Master Mode	Resistor to GND	PWM Frequency
Nominal	10 k $\Omega$	600 kHz
AM1	20 k $\Omega$	500 kHz
AM2	30 k $\Omega$	450 kHz

For slave-mode operation, turn off the oscillator by pulling the `FREQ_ADJ` pin to DVDD. This configures the `OSC_I/O` pins as inputs to be slaved from an external differential clock. In a master/slave system inter-channel delay is automatically set up between the switching phases of the audio channels, which can be illustrated by no idle channels switching at the same time. This will not influence the audio output, but only the switch timing to minimize noise coupling between audio channels through the power supply. This will optimize audio performance and result in better operating conditions for the power supply. The inter-channel delay will be set up for a slave device depending on the polarity of the `OSC_I/O` connection such that slave mode 1 is selected by connecting the `OSC_I/O` of the master device with the `OSC_I/O` of the slave device with the same polarity (+ to + and – to –), while slave mode 2 is selected by connecting the `OSC_I/O`'s with the inverse polarity (+ to – and – to +).

## 1.3 TPA3245EVM Single-Ended and Differential Input

The TPA3245EVM supports both differential and single-ended inputs. For single-ended inputs, J4 or J19 jumpers are set to the SE position, so that the TPA3245EVM uses the NE5532 to convert the single-ended input signal to differential to properly drive the differential inputs of the TPA3245. The input RCA jack, J3, is used to provide INA inputs and RCA jack J14 is used to provide INB inputs. RCA jack J18 is used to provide INC inputs and RCA jack J15 is used to provide IND inputs with differential inputs.

For differential input operation, J4 or J19 jumpers are set to the DIFF position, and the TPA3245EVM uses the NE5532 to buffer the differential input signal to the differential inputs of the TPA3245. The input RCA jack, J3, is used to provide INA, RCA jack J14 provides INB, RCA jack J18 provides INC, and RCA jack J15 provides IND with differential inputs.

- 
- NOTE:**
1. Single-ended input settings on the TPA3245EVM should only be used for channels with output configuration BTL or PBTL, not SE. However, for best performance, a differential input should be used when in BTL or PBTL modes.
  2. For SE output configuration J4 or J19 jumpers for that channel must be set to the DIFF position, so the input signal INx is mapped directly to OUTx.
-

### 1.4 TPA3245EVM Clip Overtemperature and Fault Indicators

The TPA3245EVM is equipped with LED indicators that illuminate when the  $\overline{\text{FAULT}}$  or  $\overline{\text{CLIP\_OTW}}$  pin goes low. See [Table 2](#) and the TPA3245 data sheet ([SLASEC7](#)) for more details.

**Table 2. Fault and Clip Overtemperature Status**

FAULT	CLIP_OTW	Description
0	0	Overtemperature (OTE) or overload (OLP) or undervoltage (UVP). Junction temperature higher than 125°C (overtemperature warning).
0	0	Overload (OLP) or undervoltage (UVP). Junction temperature higher than 125°C (overtemperature warning).
0	1	Overload (OLP) or undervoltage (UVP). Junction temperature lower than 125°C.
1	0	Junction temperature higher than 125°C (overtemperature warning)
1	1	Junction temperature lower than 125°C and no OLP or UVP faults (normal operation)

## 2 TPA3245EVM Setup

This section describes the TPA3245EVM hardware setup and connection.

### 2.1 TPA3245EVM Setup

Figure 2 illustrates the TPA3245EVM connection.

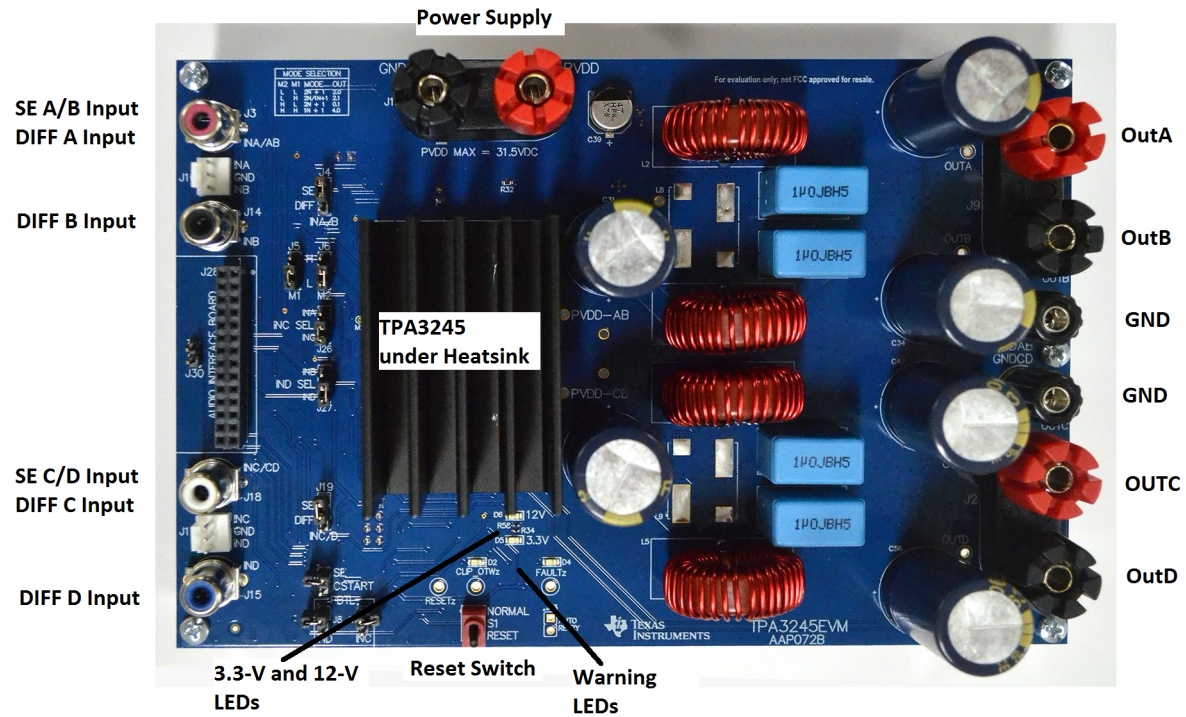

Figure 2. TPA3245EVM Connections

### 2.2 Hardware Requirements

The following hardware is required for this EVM:

- TPA3245EVM (AAP053-001)
- Power supply 5–14 A/14–31.5 V<sub>DC</sub>
- Two 2–8 Ω (approximately 200 W) speaker and resistor loads
- Four speaker/banana cables
- RCA input cables
- Analog output audio source

### 2.3 Hardware Default Setup BTL (2.0)

BTL (2.0) default hardware setup is as follows:

- Remove the EVM from the ESD bag.
- Check that jumpers are in their default state as shown in [Figure 1](#) and for stereo **BTL** operation:
- Set **S1** to the **RESET** position.
- Set power supply to 30 V (14- to 31.5-V range) and current to 10 A (5- to 14-A range). Do not power up until all connections are completed.
- Connect power supply to TPA3245EVM positive terminal to PVDD (**RED**) and negative terminal to GND (**BLACK**).
- Connect **left** channel speaker/power resistor load (4–8  $\Omega$ ) to TPA3245EVM positive output terminal to OUTA (**RED**) and AP analog input channel A positive terminal.
- Connect **left** channel speaker/power resistor load (4–8  $\Omega$ ) to TPA3245EVM negative output terminal to OUTB (**BLACK**) and AP analog input channel A negative terminal.
- Connect **right** channel speaker/power resistor load (4–8  $\Omega$ ) to TPA3245EVM positive output terminal to OUTC (**RED**) and AP analog input channel B positive terminal.
- Connect **right** channel speaker/power resistor load (4–8  $\Omega$ ) to TPA3245EVM negative output terminal to OUTD (**BLACK**) and AP analog input channel B negative terminal.
- Be careful not to mix up PVDD and OUTA and OUTB terminals, since the colors are the same (**RED**).
- For **single-ended stereo inputs**, connect AP channel A XLR to RCA male jacks to female RCA jacks input A/AB (**RED**) and AP channel B XLR to RCA male jacks to female RCA jacks input C/CD (**WHITE**) and set **J4** and **J19** jumper positions to SE.
- For **differential stereo inputs**, connect the positive RCA male jacks to female RCA jack input A/AB (**RED**) and input C/CD (**WHITE**) and connect negative RCA male jacks to female RCA jacks input B (**BLUE**) and input D (**BLACK**) and set **J4** and **J19** jumper positions to DIFF.
- Power up the power supply once all the connections are made correctly and the 3.3-V and 12-V LEDs (**GREEN**) will illuminate.
- Set **S1** to the **NORMAL** position.
- CLIP\_OTWz (**ORANGE**) and FAULTz (**RED**) LEDs should be off, if the audio source is off.

---

**NOTE:** **J3/J10** and **J18/J15** can be used for differential inputs to INA/INB and INC/IND, respectively.

---

Using a smart phone, tablet, or PC with headphone to RCA cable, audio streaming via headphone jack can begin once the EVM is powered up correctly with jumpers in their default state. Start the media player of your choice and enjoy the enhanced audio performance TPA3245 provides as a quick check of the setup.

### 3 Using the TPA3245EVM in Different Output Configurations

The TPA3245EVM can be configured for four different output operations. The 2.0 BTL configuration is the default setup of the TPA3245EVM described in [Section 2.3](#). The remaining three configurations are 2.1 BTL plus two single-ended (SE) outputs, 0.1 PBTL output, and 4.0 single-ended (SE) outputs.

**Table 3. Mode Selection Pins**

Mode Pins		Input Mode	Output Configuration	Description
M2	M1			
0	0	2N + 1	2 × BTL	Stereo BTL output configuration
0	1	2N/1N + 1	1 × BTL + 2 × SE	2.1 BTL + SE mode
1	0	2N + 1	1 × PBTL	Paralleled BTL configuration. Connect INPUT_C and INPUT_D to GND.
1	1	1N + 1	4 × SE	Single-ended output configuration

#### 3.1 BTL Plus Two SE (2.1) Operation

Configure the EVM as follows for 2 SE + 1 BTL operation:

**Table 4. SE + 1 BTL Default Jumper States**

Jumper	Setting	Comment
J29	IN	PVDD to 15-V Buck3
J31	IN	12-V LDO to 12-V terminal
J32	IN	3.3-V LDO to 3.3-V terminal
J33	IN	3.3-V LDO to 3.3-V terminal
J21	IN	CSTART SE
J16	3 to 4	Master mode
J5	1 to 2	M1 – 2XSE + BTL
J6	2 to 3	M2 - 2XSE + BTL
J22	IN	OUTA capacitor shunt
J23	IN	OUTB capacitor shunt
J24	OUT	OUTC capacitor shunt
J25	OUT	OUTD capacitor shunt
J26	2 to 3	INC select
J27	2 to 3	IND select
J7	OUT	PBTL select INC
J8	OUT	PBTL select IND
J10	OUT	INC/D DIFF input
J12	OUT	INC/D DIFF input
J4	1 to 2	INA/B SE input
J19	1 to 2	INC/D SE input

- Set **J6** to L and **J5** to H.
- Connect left (stereo) speaker/power resistor load (2–4 Ω) positive terminal to OUTC and remove jumper **J24**.
- Connect right (stereo) speaker/power resistor load (2–4 Ω) positive terminal to OUTD and remove jumper **J25**.
- Connect subwoofer (mono) speaker/power resistor load (4–8 Ω) positive terminal to OUTA and negative terminal to OUTB.
- Set **J19** jumper position to DIFF.
- Connect **left** (stereo) channel input to female RCA jack input C/CD (**WHITE**) for OUTC speaker.



- Connect **right** (stereo) channel input to female RCA jack input D (**BLACK**) for OUTD speaker.
- For **single-ended subwoofer (mono) input**, connect RCA male jack to female RCA jack input A/AB (**RED**) and set **J4** jumper positions to SE.
- For **differential subwoofer (mono) inputs**, connect positive RCA male jack to female RCA jack input A/AB (**RED**) and connect negative RCA male jack to female RCA jack input B (**YELLOW**) and set **J4** jumper positions to DIFF.

---

**NOTE:** **OUTC** and **OUTD** are the single-ended output channels and **OUTA** and **OUTB** are the BTL channel for 2.1 operations.

---

### 3.2 PBTL (0.1) Output Operation

Configure the EVM as follows for PBTL operations:

**Table 5. PBTL Default Jumper States**

Jumper	Setting	Comment
J29	IN	PVDD to 15-V Buck
J31	IN	12-V LDO to 12-V terminal
J32	IN	3.3-V LDO to 3.3-V terminal
J33	IN	3.3-V LDO to 3.3-V terminal
J21	IN	CSTART SE
J16	3 to 4	Master mode
J5	2 to 3	M1 – PBTL
J6	1 to 2	M2 – PBTL
J22	IN	OUTA capacitor shunt
J23	IN	OUTB capacitor shunt
J24	IN	OUTC capacitor shunt
J25	IN	OUTD capacitor shunt
J26	2 to 3	INC select
J27	2 to 3	IND select
J7	2 to 3	PBTL select INC – GND
J8	2 to 3	PBTL select IND – GND
J10	OUT	INC/D DIFF input
J12	OUT	INC/D DIFF input
J4	1 to 2	INA/B SE input
J19	1 to 2	INC/D SE input

- Set **J6** to H and **J5** to L.
- Connect speaker/power resistor (2–4 Ω) positive terminal to OUTA and OUTC (OUT A and C shorted).
- Connect speaker/power resistor (2–4 Ω) negative terminal to OUTB and OUTD (OUT B and D shorted).
- Install PBTL jumpers **J7** and **J8** (pulls input C and input D to GND).
- For **single-ended mono input**, connect RCA male jack to female RCA jack input A/AB (**RED**) and set **J4** jumper positions to SE.
- For **differential mono inputs**, connect positive RCA male jack to female RCA jack input A/AB (**RED**) and connect negative RCA male jack to female RCA jack input B (**YELLOW**) and set **J4** jumper position to DIFF.

---

**NOTE:** **INA** and **INB** are the inputs for PBTL and **INC** and **IND** are grounded for PBTL operation.

---

### 3.3 Single-Ended (SE) Output (4.0) Operation

Configure the EVM as follows for 4 single-ended operations:

**Table 6. SE 4.0 Default Jumper States**

Jumper	Setting	Comment
J29	IN	PVDD to 15-V Buck
J31	IN	12-V LDO to 12-V terminal
J32	IN	3.3-V LDO to 3.3-V terminal
J33	IN	3.3-V LDO to 3.3-V terminal
J21	IN	CSTART SE
J16	3 to 4	Master mode
J5	1 to 2	M1 – 4XSE
J6	1 to 2	M2 – 4XSE
J22	OUT	OUTA capacitor shunt
J23	OUT	OUTB capacitor shunt
J24	OUT	OUTC capacitor shunt
J25	OUT	OUTD capacitor shunt
J26	2 to 3	INC select
J27	2 to 3	IND select
J7	OUT	PBTL select INC
J8	OUT	PBTL select IND
J10	OUT	INC/D DIFF input
J12	OUT	INC/D DIFF input
J4	2 to 3	INA/B DIFF input
J19	2 to 3	INC/D DIFF input

- Set **J6** to H and **J5** to H.
- Connect speaker/power resistor (2–4  $\Omega$ ) positive terminal to OUTA and remove jumper **J22**.
- Connect speaker/power resistor (2–4  $\Omega$ ) positive terminal to OUTB and remove jumper **J23**.
- Connect speaker/power resistor (2–4  $\Omega$ ) positive terminal to OUTC and remove jumper **J24**.
- Connect speaker/power resistor (2–4  $\Omega$ ) positive terminal to OUTD and remove jumper **J25**.
- Set both **J4** and **J19** jumper positions to DIFF.
- Connect input to female RCA jack input A/AB (**RED**) for OUTA speaker.
- Connect input to female RCA jack input B (**YELLOW**) for OUTB speaker.
- Connect input to female RCA jack input C/CD (**WHITE**) for OUTC speaker.
- Connect input to female RCA jack input D (**BLACK**) for OUTD speaker.

---

**NOTE:** The performance of the TPA3245EVM/TPA3245 is dependent on the power supply. Design the power supply with margins that can deliver the needed power. In low-frequency applications, additional bulk capacitance may be needed. Replacing the bulk capacitors on the TPA3245EVM with more capacitance may be necessary, depending on the power supply used.

---

#### 4 Optional Inductors

The TPA3245EVM includes component pads for optional output inductors L8 and L9. These pads fit Coilcraft inductors UA8013-AL (7  $\mu\text{H}$ ) and UA8014-AL (10  $\mu\text{H}$ ). These dual-core inductors provide extremely high performance in a small footprint to help shrink the solution size and cost. If using L8 and L9, make sure to de-solder L2, L3, L4, and L5 first.

The plot in Figure 3 shows THD + N vs. output power for the TPA3245EVM using the standard toroid inductors and the Coilcraft UA8013-AL (7  $\mu\text{H}$ ) and UA8014-AL (10  $\mu\text{H}$ ).

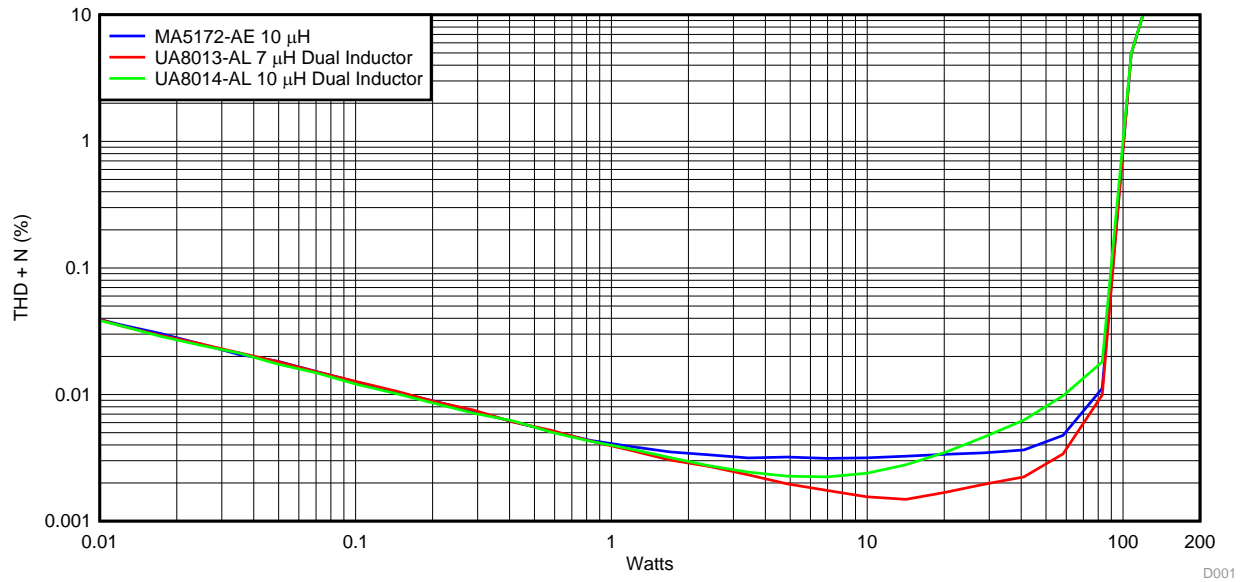

Figure 3. TPA3245EVM THD + N vs Output Power 30 V, BTL 4  $\Omega$ , 600 kHz

## 5 Board Layouts, Bill of Materials, and Schematic

### 5.1 TPA3245EVM Board Layouts

Figure 4 and Figure 5 illustrate the board layouts for the EVM.

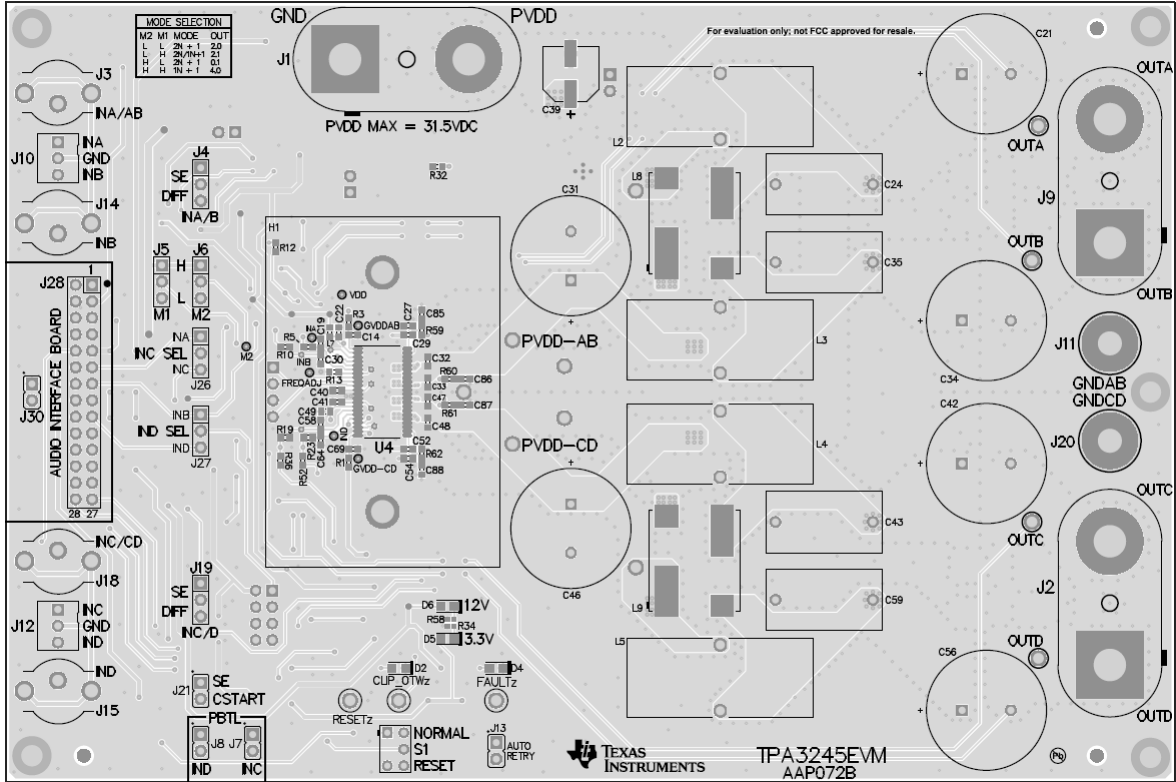

Figure 4. TPA3245EVM Top Composite Assembly

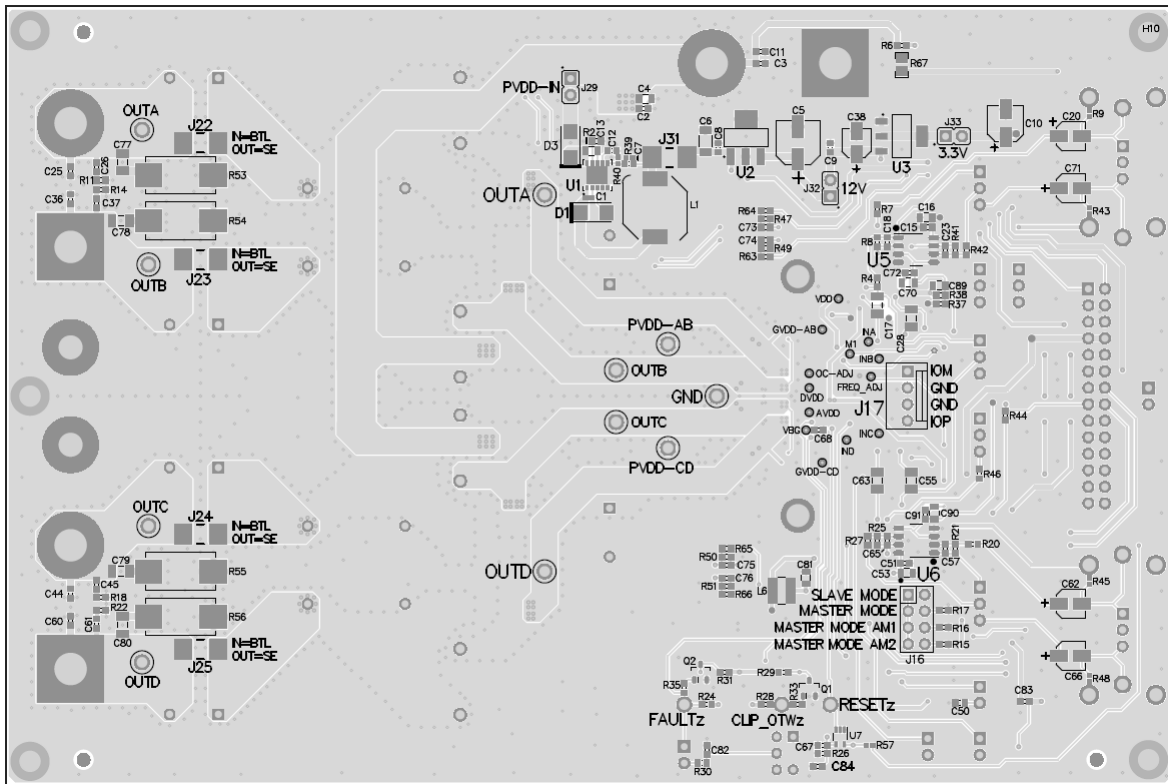
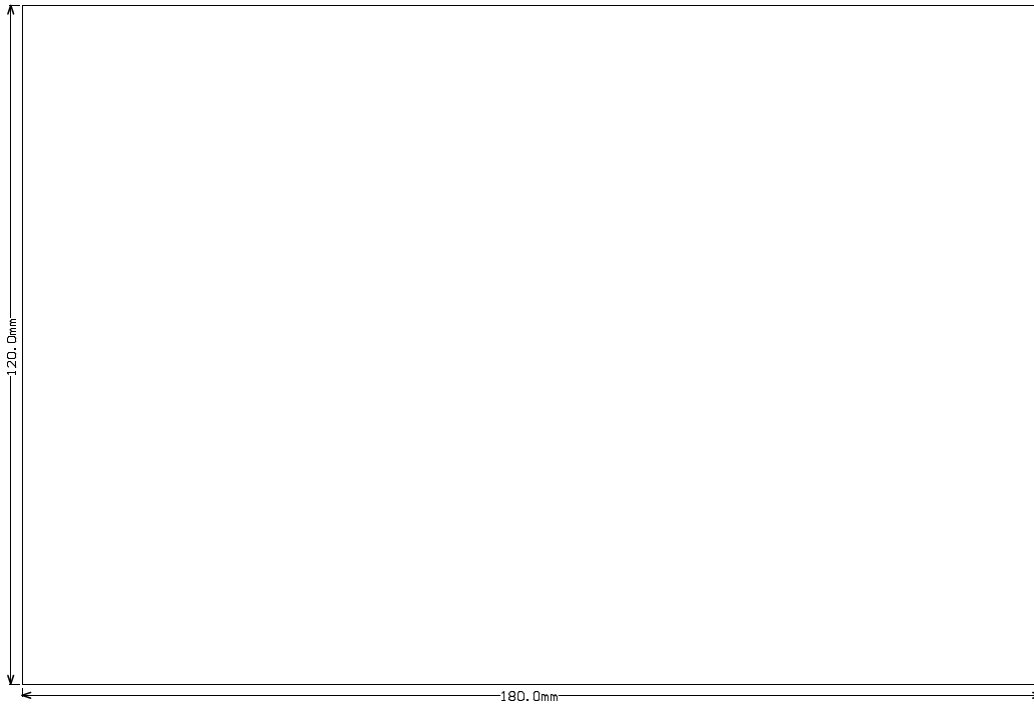

Figure 5. TPA3245EVM Bottom Composite Assembly

## 5.2 TPA3245EVM Board Dimension

Figure 6 illustrates the TPA3245EVM board dimensions 180 mm × 120 mm (image represented here is not actual size).



**Figure 6. TPA3245EVM Board Dimension**

### 5.3 Bill of Materials

Table 7 displays the BOM for this EVM.

**Table 7. Bill of Materials**

Designator	Qty	Value	Description	Package Reference	Part Number	Manufacturer
IPCB	1		Printed Circuit Board		AAP072	Any
C1	1	0.047uF	CAP, CERM, 0.047 $\mu$ F, 25 V, +/- 10%, X7R, 0402	0402	GRM155R71E473KA88D	Murata
C2, C9, C13, C14, C15, C22, C51, C67, C68, C69, C72, C82, C91	13	0.1uF	CAP, CERM, 0.1 $\mu$ F, 50 V, +/- 10%, X7R, 0603	0603	C0603C104K5RACTU	Kemet
C3, C32, C33, C47, C48, C83, C84	7	1uF	CAP, CERM, 1 $\mu$ F, 50 V, +/- 10%, X7R, 0603	0603	UMK107AB7105KA-T	Taiyo Yuden
C4	1	2.2uF	CAP, CERM, 2.2 $\mu$ F, 50 V, +/- 10%, X7R, 0805	0805	C2012X7R1H225K125AC	TDK
C5	1	47uF	CAP, AL, 47 $\mu$ F, 16 V, +/- 20%, 0.36 ohm, SMD	SMT Radial D	EEE-FK1C470P	Panasonic
C6	1	4.7uF	CAP, CERM, 4.7 $\mu$ F, 25 V, +/- 10%, X7R, 1206	1206	GRM31CR71E475KA88L	Murata
C7	1	5600pF	CAP, CERM, 5600 pF, 50 V, +/- 10%, X7R, 0603	0603	GRM188R71H562KA01D	Murata
C8, C50	2	0.47uF	CAP, CERM, 0.47 $\mu$ F, 25 V, +/- 10%, X7R, 0603	0603	GRM188R71E474KA12D	Murata
C10	1	100uF	CAP, AL, 100 $\mu$ F, 6.3 V, +/- 20%, 0.7 ohm, SMD	SMT Radial C	EEE-FK0J101UR	Panasonic
C11, C26, C37, C45, C61	5	0.01uF	CAP, CERM, 0.01 $\mu$ F, 50 V, +/- 10%, X7R, 0603	0603	C0603C103K5RACTU	Kemet
C12	1	4700pF	CAP, CERM, 4700 pF, 50 V, +/- 10%, X7R, 0603	0603	C0603X472K5RACTU	Kemet
C16, C53, C70, C81, C89, C90	6	10uF	CAP, CERM, 10 $\mu$ F, 16 V, +/- 10%, X5R, 0805	0805	EMK212BJ106KG-T	Taiyo Yuden
C17, C28, C55, C63	4	10uF	CAP, CERM, 10 $\mu$ F, 16 V, +/- 10%, X7R, 1206	1206	GRM31CR71C106KAC7L	Murata
C18, C23, C57, C65	4	22pF	CAP, CERM, 22 pF, 50 V, +/- 5%, C0G/NP0, 0603	0603	GRM1885C1H220JA01D	Murata
C19, C30, C58, C64	4	100pF	CAP, CERM, 100 pF, 50 V, +/- 5%, C0G/NP0, 0603	0603	GRM1885C1H101JA01D	Murata
C20, C38, C62, C66, C71	5	10uF	CAP, AL, 10 $\mu$ F, 16 V, +/- 20%, 1.35 ohm, SMD	SMT Radial B	EEE-FK1C100R	Panasonic
C21, C34, C42, C56	4	1500uF	CAP, AL, 1500 $\mu$ F, 63 V, +/- 20%, 0.03 ohm, AEC-Q200 Grade 2, TH	Dia 18mm	EEU-FC1J152	Panasonic
C24, C35, C43, C59	4	1uF	CAP, Film, 1 $\mu$ F, 250 V, +/- 5%, TH	18x9.5x17.5mm	PHE426HB7100JR06	Kemet
C25, C36, C44, C60	4	1000pF	CAP, CERM, 1000 pF, 50 V, +/- 1%, C0G/NP0, 0603	0603	GRM1885C1H102FA01J	Murata
C27, C29, C52, C54	4	0.033uF	CAP, CERM, 0.033 $\mu$ F, 25 V, +/- 10%, X7R, 0603	0603	GRM188R71E333KA01D	Murata
C31, C46	2	2200uF	CAP, AL, 2200 $\mu$ F, 50 V, +/- 20%, 0.023 ohm, AEC-Q200 Grade 2, TH	Dia 18mm	EEU-FC1H222	Panasonic
C39	1	47uF	CAP, AL, 47 $\mu$ F, 50 V, +/- 20%, 0.68 ohm, SMD	SMT Radial E	EEE-FK1H470P	Panasonic
C40, C41	2	1uF	CAP, CERM, 1 $\mu$ F, 16 V, +/- 10%, X7R, 0603	0603	GRM188R71C105KA12D	Murata
C49	1	0.047uF	CAP, CERM, 0.047 $\mu$ F, 50 V, +/- 10%, X7R, 0603	0603	GRM188R71H473KA61D	Murata
D1	1	100V	Diode, Schottky, 100 V, 1 A, SMA	SMA	B1100-13-F	Diodes Inc.
D2	1	Orange	LED, Orange, SMD	LED_0805	LTST-C170KFKT	Lite-On
D3	1	100V	Diode, Schottky, 100 V, 3 A, SMA	SMA	SK310A-TP	Micro Commercial Components
D4	1	Red	LED, Red, SMD	Red 0805 LED	LTST-C170KRKT	Lite-On
D5, D6	2	Green	LED, Green, SMD	LED_0805	LTST-C171GKT	Lite-On
H1	1		HEATSINK TI TAS5612 AND TAS5614	HEATSINK TI TAS5612 AND TAS5614	ATS-TI10P-563-C1-R0	Advanced Thermal Solutions



**Table 7. Bill of Materials (continued)**

Designator	Qty	Value	Description	Package Reference	Part Number	Manufacturer
H2, H3, H4, H5, H6, H12, H13	7		MACHINE SCREW PAN PHILLIPS M3	M3 Screw	RM3X8MM 2701	APM HEXSEAL
H7, H8, H9, H10, H11	5		Standoff, Hex,25mm Length, M3, Aluminum	Standoff M3	24438	Keystone
J1, J2, J9	3		Dual Binding Posts with Base, 2x1, TH	Dual Binding Posts with Base, 2x1, TH	6883	Pomona Electronics
J3	1		RCA Jack, Vertical, Red, TH	RCA JACK, RED	RCJ-022	CUI Inc.
J4, J5, J6, J19, J26, J27	6		Header, 100mil, 3x1, Gold, TH	PBC03SAAN	PBC03SAAN	Sullins Connector Solutions
J7, J8, J21, J29, J30, J32, J33	7		Header, 100mil, 2x1, Gold, TH	Sullins 100mil, 1x2, 230 mil above insulator	PBC02SAAN	Sullins Connector Solutions
J10, J12	2		Header, 2.54 mm, 3x1, TH	Header, 2.54mm, 3x1, TH	22-11-2032	Molex
J11, J20	2		Binding Post, BLACK, TH	11.4x27.2mm	7007	Keystone
J14	1		RCA Jack, Vertical, Black, TH	RCA Jack, Vertical, Black, TH	RCJ-021	CUI Inc.
J15	1		RCA Jack, Vertical, Blue, TH	RCA Jack, Vertical, Blue, TH	RCJ-025	CUI Inc.
J16	1		Header, 100mil, 4x2, Tin, TH	Header, 4x2, 100mil, Tin	PEC04DAAN	Sullins Connector Solutions
J17	1		Header (friction lock), 100mil, 4x1, Gold, TH	Header 4x1 keyed	0022112042	Molex
J18	1		RCA Jack, Vertical, White, TH	RCA JACK, WHITE	RCJ-023	CUI Inc.
J22, J23, J24, J25, J31	5		JUMPER TIN SMD	6.85x0.97x2.51 mm	S1911-46R	Harwin
J28	1		Receptacle, 100mil, 14x2, Gold, TH	14x2 Receptacle	SSW-114-01-G-D	Samtec
L1	1	100uH	Inductor, Shielded Drum Core, Ferrite, 100 µH, 1.5 A, 0.165 ohm, SMD	SMD	7447714101	Würth Elektronik
L2, L3, L4, L5	4	10uH	Inductor, Toroid, Powdered Iron, 10 µH, 6.1 A, 0.026 ohm, TH	28.6x12.3mm	MA5172-AE	Coilcraft
L6	1	10uH	Inductor, Wirewound, 10 µH, 0.8 A, 0.204 ohm, SMD	2-Pin SMD, Body 4 x 4 mm, Height 1.2 mm	NRS4012T100MDGJV	Taiyo Yuden
L7	1	10uH	Inductor, Wirewound, 10 µH, 0.08 A, 0.36 ohm, SMD	0603	GLFR1608T100M-LR	TDK
Q1, Q2	2	60V	MOSFET, N-CH, 60 V, 0.17 A, SOT-23	SOT-23	2N7002-7-F	Diodes Inc.
R1, R3, R4, R12, R30, R44, R46	7	0	RES, 0, 5%, 0.1 W, 0603	0603	CRCW06030000Z0EA	Vishay-Dale
R2	1	182k	RES, 182 k, 1%, 0.125 W, 0805	0805	ERJ-6ENF1823V	Panasonic
R5, R10, R19, R23, R33, R35	6	100	RES, 100, 1%, 0.1 W, 0603	0603	CRCW0603100RFKEA	Vishay-Dale
R6	1	100k	RES, 100 k, 1%, 0.1 W, 0603	0603	CRCW0603100KFKEA	Vishay-Dale
R7, R8, R20, R21, R25, R27, R37, R38, R41, R42	10	10.0k	RES, 10.0 k, 0.1%, 0.1 W, 0603	0603	RT0603BRD0710KL	Yageo America
R9, R43, R45, R48	4	100k	RES, 100 k, 1%, 0.063 W, 0402	0402	CRCW0402100KFKEA	Vishay-Dale
R11, R14, R18, R22	4	3.3	RES, 3.3, 5%, 0.1 W, 0603	0603	CRCW06033R30JNEA	Vishay-Dale
R13	1	22.0k	RES, 22.0 k, 1%, 0.1 W, 0603	0603	RC0603FR-0722KL	Yageo America
R15	1	30.0k	RES, 30.0 k, 1%, 0.1 W, 0603	0603	RC0603FR-0730KL	Yageo America
R16	1	20.0k	RES, 20.0 k, 1%, 0.1 W, 0603	0603	RC0603FR-0720KL	Yageo America
R17, R36, R52	3	10.0k	RES, 10.0 k, 1%, 0.1 W, 0603	0603	CRCW060310K0FKEA	Vishay-Dale
R24, R28	2	47k	RES, 47 k, 5%, 0.1 W, 0603	0603	RC0603JR-0747KL	Yageo America
R26	1	3.30k	RES, 3.30 k, 1%, 0.1 W, 0603	0603	RC0603FR-073K3L	Yageo America

**Table 7. Bill of Materials (continued)**

Designator	Qty	Value	Description	Package Reference	Part Number	Manufacturer
R29, R31	2	1.00k	RES, 1.00 k, 1%, 0.1 W, 0603	0603	CRCW06031K00FKEA	Vishay-Dale
R32	1	9.10k	RES, 9.10 k, 1%, 0.1 W, 0603	0603	RC0603FR-079K1L	Yageo America
R34	1	360	RES, 360, 5%, 0.063 W, 0402	0402	CRCW0402360RJNED	Vishay-Dale
R39	1	4.99k	RES, 4.99 k, 1%, 0.063 W, 0402	0402	CRCW04024K99FKED	Vishay-Dale
R40	1	1.00k	RES, 1.00 k, 1%, 0.063 W, 0402	0402	CRCW04021K00FKED	Vishay-Dale
R57	1	1.00k	RES, 1.00 k, 1%, 0.1 W, 0402	0402	ERJ-2RKF1001X	Panasonic
R58	1	1.50k	RES, 1.50 k, 1%, 0.063 W, 0402	0402	CRCW04021K50FKED	Vishay-Dale
S1	1		Switch, SPDT, On-On, 2 Pos, TH	Switch, 7x4.5mm	200USP1T1A1M2RE	E-Switch
SH1, SH2, SH3, SH4, SH5, SH6, SH7, SH8, SH9, SH10, SH11, SH12, SH13	13	1x2	Shunt, 100mil, Gold plated, Black	Shunt	969102-0000-DA	3M
U1	1		High Voltage 1A Step Down Switching Regulator, 10-pin LLP, Pb-Free	SDC10A	LM5010ASD/NOPB	Texas Instruments
U2	1		1A Low Dropout Regulator, 4-pin SOT-223, Pb-Free	MP04A	LM2940IMP-12/NOPB	Texas Instruments
U3	1		FIXED LOW-DROPOUT VOLTAGE REGULATOR, DCY0004A	DCY0004A	TLV1117-33IDCY	Texas Instruments
U4	1		150W Stereo/300W MONO PurePath HD Analog-input Power Stage, DDV0044D	DDV0044D	TPA3245DDVR	Texas Instruments
U5, U6	2		Dual Low-Noise Operational Amplifier, 10 to 30 V, 0 to 70 degC, 8-pin SOIC (D0008A), Green (RoHS & no Sb/Br)	D0008A	NE5532ADR	Texas Instruments
U7	1		ULTRA-SMALL SUPPLY VOLTAGE SUPERVISORS, DCK0005A	DCK0005A	TPS3802K33DCKR	Texas Instruments
C73, C74, C75, C76	0	22pF	CAP, CERM, 22 pF, 50 V, +/- 5%, COG/NP0, 0603	0603	GRM1885C1H220JA01D	Murata
C77, C78, C79, C80	0	1uF	CAP, CERM, 1 µF, 50 V, +/- 10%, X7R, 1206	1206	GRM31MR71H105KA88L	Murata
C85, C86, C87, C88	0	1000pF	CAP, CERM, 1000 pF, 50 V, +/- 1%, COG/NP0, 0603	0603	GRM1885C1H102FA01J	Murata
FID1, FID2, FID3, FID4, FID5, FID6	0		Fiducial mark. There is nothing to buy or mount.	N/A	N/A	N/A
J13	0		Header, 100mil, 2x1, Gold, TH	Sullins 100mil, 1x2, 230 mil above insulator	PBC02SAAN	Sullins Connector Solutions
L8, L9	0	5uH	Coupled inductor, 5 µH, 16.6 A, 0.006 ohm, SMD	15.5x14mm	RA7231-ALB	Coilcraft
R47, R49, R50, R51	0	18.0k	RES, 18.0 k, 1%, 0.1 W, 0603	0603	RC0603FR-0718KL	Yageo America
R53, R54, R55, R56	0	2.7	RES, 2.7, 5%, 3 W, SM_3, 10.5x5x5.5mm	SM_3, 10.5x5x5.5mm	SMW32R7JT	TE Connectivity
R59, R60, R61, R62	0	10.0	RES, 10.0, 1%, 0.1 W, 0603	0603	CRCW060310R0FKEA	Vishay-Dale
R63, R64, R65, R66	0	0	RES, 0, 5%, 0.1 W, 0603	0603	CRCW0603000Z0EA	Vishay-Dale
R67	0	0	RES, 0, 5%, 0.125 W, 0805	0805	ERJ-6GEY0R00V	Panasonic
TP1, TP2, TP3, TP4, TP5, TP6, TP7, TP8, TP9, TP10, TP11, TP12, TP13, TP14	0		Test Point, Multipurpose, Grey, TH	Grey Multipurpose Testpoint	5128	Keystone
TP15, TP16, TP17, TP18, TP19, TP20, TP21, TP22, TP23, TP24, TP25, TP26, TP27, TP28	0		Testpoint	Test Point, 0.45mm hole size	TP_H0.45P0.75	Texas Instruments

### 5.4 TPA3245EVM Schematic

The schematics for TPA3245EVM are illustrated in Figure 7 through Figure 9.

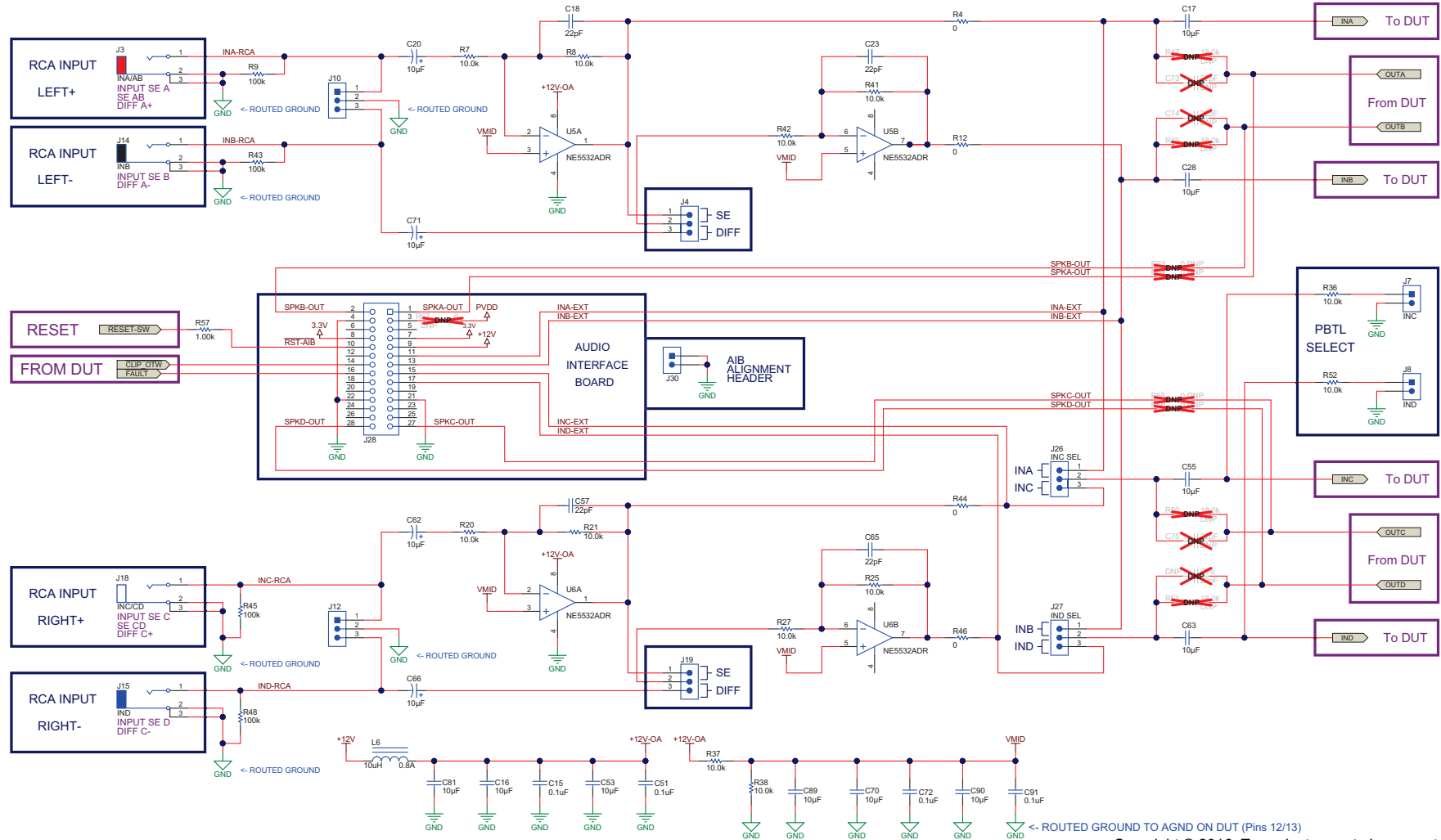
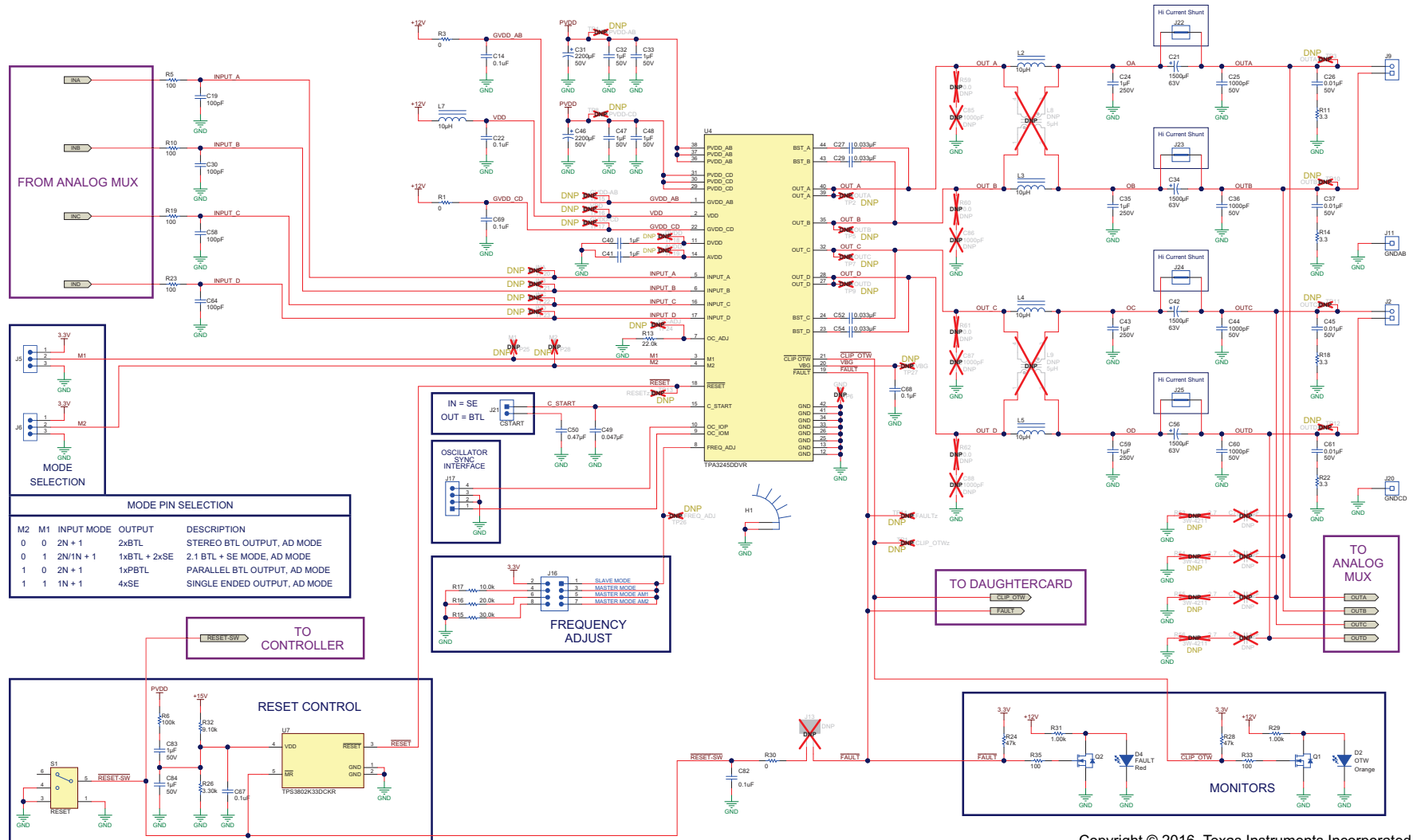
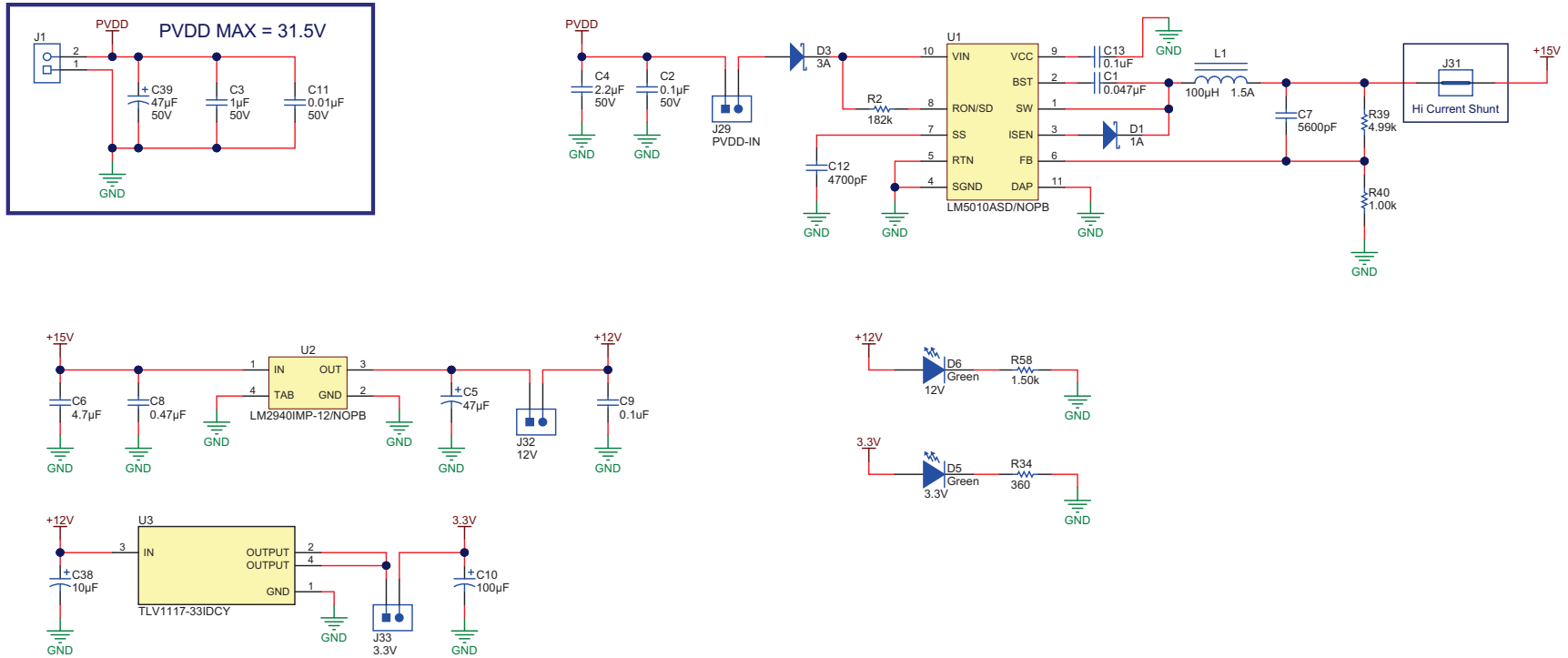

Figure 7. TPA3245EVM Schematic 1



Copyright © 2016, Texas Instruments Incorporated

Figure 8. TPA3245EVM Schematic 2



Copyright © 2016, Texas Instruments Incorporated

Figure 9. TPA3245EVM Schematic 3

## STANDARD TERMS AND CONDITIONS FOR EVALUATION MODULES

1. *Delivery:* TI delivers TI evaluation boards, kits, or modules, including demonstration software, components, and/or documentation which may be provided together or separately (collectively, an "EVM" or "EVMs") to the User ("User") in accordance with the terms and conditions set forth herein. Acceptance of the EVM is expressly subject to the following terms and conditions.
  - 1.1 EVMs are intended solely for product or software developers for use in a research and development setting to facilitate feasibility evaluation, experimentation, or scientific analysis of TI semiconductors products. EVMs have no direct function and are not finished products. EVMs shall not be directly or indirectly assembled as a part or subassembly in any finished product. For clarification, any software or software tools provided with the EVM ("Software") shall not be subject to the terms and conditions set forth herein but rather shall be subject to the applicable terms and conditions that accompany such Software
  - 1.2 EVMs are not intended for consumer or household use. EVMs may not be sold, sublicensed, leased, rented, loaned, assigned, or otherwise distributed for commercial purposes by Users, in whole or in part, or used in any finished product or production system.
2. *Limited Warranty and Related Remedies/Disclaimers:*
  - 2.1 These terms and conditions do not apply to Software. The warranty, if any, for Software is covered in the applicable Software License Agreement.
  - 2.2 TI warrants that the TI EVM will conform to TI's published specifications for ninety (90) days after the date TI delivers such EVM to User. Notwithstanding the foregoing, TI shall not be liable for any defects that are caused by neglect, misuse or mistreatment by an entity other than TI, including improper installation or testing, or for any EVMs that have been altered or modified in any way by an entity other than TI. Moreover, TI shall not be liable for any defects that result from User's design, specifications or instructions for such EVMs. Testing and other quality control techniques are used to the extent TI deems necessary or as mandated by government requirements. TI does not test all parameters of each EVM.
  - 2.3 If any EVM fails to conform to the warranty set forth above, TI's sole liability shall be at its option to repair or replace such EVM, or credit User's account for such EVM. TI's liability under this warranty shall be limited to EVMs that are returned during the warranty period to the address designated by TI and that are determined by TI not to conform to such warranty. If TI elects to repair or replace such EVM, TI shall have a reasonable time to repair such EVM or provide replacements. Repaired EVMs shall be warranted for the remainder of the original warranty period. Replaced EVMs shall be warranted for a new full ninety (90) day warranty period.
3. *Regulatory Notices:*
  - 3.1 *United States*
    - 3.1.1 *Notice applicable to EVMs not FCC-Approved:*

This kit is designed to allow product developers to evaluate electronic components, circuitry, or software associated with the kit to determine whether to incorporate such items in a finished product and software developers to write software applications for use with the end product. This kit is not a finished product and when assembled may not be resold or otherwise marketed unless all required FCC equipment authorizations are first obtained. Operation is subject to the condition that this product not cause harmful interference to licensed radio stations and that this product accept harmful interference. Unless the assembled kit is designed to operate under part 15, part 18 or part 95 of this chapter, the operator of the kit must operate under the authority of an FCC license holder or must secure an experimental authorization under part 5 of this chapter.
    - 3.1.2 *For EVMs annotated as FCC – FEDERAL COMMUNICATIONS COMMISSION Part 15 Compliant:*

### CAUTION

This device complies with part 15 of the FCC Rules. Operation is subject to the following two conditions: (1) This device may not cause harmful interference, and (2) this device must accept any interference received, including interference that may cause undesired operation.

Changes or modifications not expressly approved by the party responsible for compliance could void the user's authority to operate the equipment.

### FCC Interference Statement for Class A EVM devices

*NOTE: This equipment has been tested and found to comply with the limits for a Class A digital device, pursuant to part 15 of the FCC Rules. These limits are designed to provide reasonable protection against harmful interference when the equipment is operated in a commercial environment. This equipment generates, uses, and can radiate radio frequency energy and, if not installed and used in accordance with the instruction manual, may cause harmful interference to radio communications. Operation of this equipment in a residential area is likely to cause harmful interference in which case the user will be required to correct the interference at his own expense.*

## FCC Interference Statement for Class B EVM devices

*NOTE: This equipment has been tested and found to comply with the limits for a Class B digital device, pursuant to part 15 of the FCC Rules. These limits are designed to provide reasonable protection against harmful interference in a residential installation. This equipment generates, uses and can radiate radio frequency energy and, if not installed and used in accordance with the instructions, may cause harmful interference to radio communications. However, there is no guarantee that interference will not occur in a particular installation. If this equipment does cause harmful interference to radio or television reception, which can be determined by turning the equipment off and on, the user is encouraged to try to correct the interference by one or more of the following measures:*

- Reorient or relocate the receiving antenna.
- Increase the separation between the equipment and receiver.
- Connect the equipment into an outlet on a circuit different from that to which the receiver is connected.
- Consult the dealer or an experienced radio/TV technician for help.

### 3.2 Canada

3.2.1 For EVMs issued with an Industry Canada Certificate of Conformance to RSS-210

#### Concerning EVMs Including Radio Transmitters:

This device complies with Industry Canada license-exempt RSS standard(s). Operation is subject to the following two conditions: (1) this device may not cause interference, and (2) this device must accept any interference, including interference that may cause undesired operation of the device.

#### Concernant les EVMs avec appareils radio:

Le présent appareil est conforme aux CNR d'Industrie Canada applicables aux appareils radio exempts de licence. L'exploitation est autorisée aux deux conditions suivantes: (1) l'appareil ne doit pas produire de brouillage, et (2) l'utilisateur de l'appareil doit accepter tout brouillage radioélectrique subi, même si le brouillage est susceptible d'en compromettre le fonctionnement.

#### Concerning EVMs Including Detachable Antennas:

Under Industry Canada regulations, this radio transmitter may only operate using an antenna of a type and maximum (or lesser) gain approved for the transmitter by Industry Canada. To reduce potential radio interference to other users, the antenna type and its gain should be so chosen that the equivalent isotropically radiated power (e.i.r.p.) is not more than that necessary for successful communication. This radio transmitter has been approved by Industry Canada to operate with the antenna types listed in the user guide with the maximum permissible gain and required antenna impedance for each antenna type indicated. Antenna types not included in this list, having a gain greater than the maximum gain indicated for that type, are strictly prohibited for use with this device.

#### Concernant les EVMs avec antennes détachables

Conformément à la réglementation d'Industrie Canada, le présent émetteur radio peut fonctionner avec une antenne d'un type et d'un gain maximal (ou inférieur) approuvé pour l'émetteur par Industrie Canada. Dans le but de réduire les risques de brouillage radioélectrique à l'intention des autres utilisateurs, il faut choisir le type d'antenne et son gain de sorte que la puissance isotrope rayonnée équivalente (p.i.r.e.) ne dépasse pas l'intensité nécessaire à l'établissement d'une communication satisfaisante. Le présent émetteur radio a été approuvé par Industrie Canada pour fonctionner avec les types d'antenne énumérés dans le manuel d'usage et ayant un gain admissible maximal et l'impédance requise pour chaque type d'antenne. Les types d'antenne non inclus dans cette liste, ou dont le gain est supérieur au gain maximal indiqué, sont strictement interdits pour l'exploitation de l'émetteur.

### 3.3 Japan

3.3.1 *Notice for EVMs delivered in Japan:* Please see [http://www.tij.co.jp/llds/ti\\_ja/general/eStore/notice\\_01.page](http://www.tij.co.jp/llds/ti_ja/general/eStore/notice_01.page) 日本国内に輸入される評価用キット、ボードについては、次のところをご覧ください。  
[http://www.tij.co.jp/llds/ti\\_ja/general/eStore/notice\\_01.page](http://www.tij.co.jp/llds/ti_ja/general/eStore/notice_01.page)

3.3.2 *Notice for Users of EVMs Considered "Radio Frequency Products" in Japan:* EVMs entering Japan may not be certified by TI as conforming to Technical Regulations of Radio Law of Japan.

If User uses EVMs in Japan, not certified to Technical Regulations of Radio Law of Japan, User is required by Radio Law of Japan to follow the instructions below with respect to EVMs:

1. Use EVMs in a shielded room or any other test facility as defined in the notification #173 issued by Ministry of Internal Affairs and Communications on March 28, 2006, based on Sub-section 1.1 of Article 6 of the Ministry's Rule for Enforcement of Radio Law of Japan,
2. Use EVMs only after User obtains the license of Test Radio Station as provided in Radio Law of Japan with respect to EVMs, or
3. Use of EVMs only after User obtains the Technical Regulations Conformity Certification as provided in Radio Law of Japan with respect to EVMs. Also, do not transfer EVMs, unless User gives the same notice above to the transferee. Please note that if User does not follow the instructions above, User will be subject to penalties of Radio Law of Japan.

【無線電波を送信する製品の開発キットをお使いになる際の注意事項】 開発キットの中には技術基準適合証明を受けていないものがあります。技術適合証明を受けていないものご使用に際しては、電波法遵守のため、以下のいずれかの措置を取っていただく必要がありますのでご注意ください。

1. 電波法施行規則第6条第1項第1号に基づく平成18年3月28日総務省告示第173号で定められた電波暗室等の試験設備でご使用いただく。
2. 実験局の免許を取得後ご使用いただく。
3. 技術基準適合証明を取得後ご使用いただく。

なお、本製品は、上記の「ご使用にあたっての注意」を譲渡先、移転先に通知しない限り、譲渡、移転できないものとします。

上記を遵守頂けない場合は、電波法の罰則が適用される可能性があることをご留意ください。日本テキサス・インスツルメンツ株式会社

東京都新宿区西新宿 6 丁目 2 4 番 1 号

西新宿三井ビル

3.3.3 *Notice for EVMs for Power Line Communication:* Please see [http://www.tij.co.jp/lstds/ti\\_ja/general/eStore/notice\\_02.page](http://www.tij.co.jp/lstds/ti_ja/general/eStore/notice_02.page)  
電力線搬送波通信についての開発キットをお使いになる際の注意事項については、次のところをご覧ください。 [http://www.tij.co.jp/lstds/ti\\_ja/general/eStore/notice\\_02.page](http://www.tij.co.jp/lstds/ti_ja/general/eStore/notice_02.page)

#### 4 *EVM Use Restrictions and Warnings:*

4.1 EVMS ARE NOT FOR USE IN FUNCTIONAL SAFETY AND/OR SAFETY CRITICAL EVALUATIONS, INCLUDING BUT NOT LIMITED TO EVALUATIONS OF LIFE SUPPORT APPLICATIONS.

4.2 User must read and apply the user guide and other available documentation provided by TI regarding the EVM prior to handling or using the EVM, including without limitation any warning or restriction notices. The notices contain important safety information related to, for example, temperatures and voltages.

#### 4.3 *Safety-Related Warnings and Restrictions:*

4.3.1 User shall operate the EVM within TI's recommended specifications and environmental considerations stated in the user guide, other available documentation provided by TI, and any other applicable requirements and employ reasonable and customary safeguards. Exceeding the specified performance ratings and specifications (including but not limited to input and output voltage, current, power, and environmental ranges) for the EVM may cause personal injury or death, or property damage. If there are questions concerning performance ratings and specifications, User should contact a TI field representative prior to connecting interface electronics including input power and intended loads. Any loads applied outside of the specified output range may also result in unintended and/or inaccurate operation and/or possible permanent damage to the EVM and/or interface electronics. Please consult the EVM user guide prior to connecting any load to the EVM output. If there is uncertainty as to the load specification, please contact a TI field representative. During normal operation, even with the inputs and outputs kept within the specified allowable ranges, some circuit components may have elevated case temperatures. These components include but are not limited to linear regulators, switching transistors, pass transistors, current sense resistors, and heat sinks, which can be identified using the information in the associated documentation. When working with the EVM, please be aware that the EVM may become very warm.

4.3.2 EVMs are intended solely for use by technically qualified, professional electronics experts who are familiar with the dangers and application risks associated with handling electrical mechanical components, systems, and subsystems. User assumes all responsibility and liability for proper and safe handling and use of the EVM by User or its employees, affiliates, contractors or designees. User assumes all responsibility and liability to ensure that any interfaces (electronic and/or mechanical) between the EVM and any human body are designed with suitable isolation and means to safely limit accessible leakage currents to minimize the risk of electrical shock hazard. User assumes all responsibility and liability for any improper or unsafe handling or use of the EVM by User or its employees, affiliates, contractors or designees.

4.4 User assumes all responsibility and liability to determine whether the EVM is subject to any applicable international, federal, state, or local laws and regulations related to User's handling and use of the EVM and, if applicable, User assumes all responsibility and liability for compliance in all respects with such laws and regulations. User assumes all responsibility and liability for proper disposal and recycling of the EVM consistent with all applicable international, federal, state, and local requirements.

5. *Accuracy of Information:* To the extent TI provides information on the availability and function of EVMs, TI attempts to be as accurate as possible. However, TI does not warrant the accuracy of EVM descriptions, EVM availability or other information on its websites as accurate, complete, reliable, current, or error-free.



6. *Disclaimers:*
- 6.1 EXCEPT AS SET FORTH ABOVE, EVMS AND ANY WRITTEN DESIGN MATERIALS PROVIDED WITH THE EVM (AND THE DESIGN OF THE EVM ITSELF) ARE PROVIDED "AS IS" AND "WITH ALL FAULTS." TI DISCLAIMS ALL OTHER WARRANTIES, EXPRESS OR IMPLIED, REGARDING SUCH ITEMS, INCLUDING BUT NOT LIMITED TO ANY IMPLIED WARRANTIES OF MERCHANTABILITY OR FITNESS FOR A PARTICULAR PURPOSE OR NON-INFRINGEMENT OF ANY THIRD PARTY PATENTS, COPYRIGHTS, TRADE SECRETS OR OTHER INTELLECTUAL PROPERTY RIGHTS.
- 6.2 EXCEPT FOR THE LIMITED RIGHT TO USE THE EVM SET FORTH HEREIN, NOTHING IN THESE TERMS AND CONDITIONS SHALL BE CONSTRUED AS GRANTING OR CONFERRING ANY RIGHTS BY LICENSE, PATENT, OR ANY OTHER INDUSTRIAL OR INTELLECTUAL PROPERTY RIGHT OF TI, ITS SUPPLIERS/LICENSORS OR ANY OTHER THIRD PARTY, TO USE THE EVM IN ANY FINISHED END-USER OR READY-TO-USE FINAL PRODUCT, OR FOR ANY INVENTION, DISCOVERY OR IMPROVEMENT MADE, CONCEIVED OR ACQUIRED PRIOR TO OR AFTER DELIVERY OF THE EVM.
7. *USER'S INDEMNITY OBLIGATIONS AND REPRESENTATIONS.* USER WILL DEFEND, INDEMNIFY AND HOLD TI, ITS LICENSORS AND THEIR REPRESENTATIVES HARMLESS FROM AND AGAINST ANY AND ALL CLAIMS, DAMAGES, LOSSES, EXPENSES, COSTS AND LIABILITIES (COLLECTIVELY, "CLAIMS") ARISING OUT OF OR IN CONNECTION WITH ANY HANDLING OR USE OF THE EVM THAT IS NOT IN ACCORDANCE WITH THESE TERMS AND CONDITIONS. THIS OBLIGATION SHALL APPLY WHETHER CLAIMS ARISE UNDER STATUTE, REGULATION, OR THE LAW OF TORT, CONTRACT OR ANY OTHER LEGAL THEORY, AND EVEN IF THE EVM FAILS TO PERFORM AS DESCRIBED OR EXPECTED.
8. *Limitations on Damages and Liability:*
- 8.1 *General Limitations.* IN NO EVENT SHALL TI BE LIABLE FOR ANY SPECIAL, COLLATERAL, INDIRECT, PUNITIVE, INCIDENTAL, CONSEQUENTIAL, OR EXEMPLARY DAMAGES IN CONNECTION WITH OR ARISING OUT OF THESE TERMS AND CONDITIONS OR THE USE OF THE EVMS PROVIDED HEREUNDER, REGARDLESS OF WHETHER TI HAS BEEN ADVISED OF THE POSSIBILITY OF SUCH DAMAGES. EXCLUDED DAMAGES INCLUDE, BUT ARE NOT LIMITED TO, COST OF REMOVAL OR REINSTALLATION, ANCILLARY COSTS TO THE PROCUREMENT OF SUBSTITUTE GOODS OR SERVICES, RETESTING, OUTSIDE COMPUTER TIME, LABOR COSTS, LOSS OF GOODWILL, LOSS OF PROFITS, LOSS OF SAVINGS, LOSS OF USE, LOSS OF DATA, OR BUSINESS INTERRUPTION. NO CLAIM, SUIT OR ACTION SHALL BE BROUGHT AGAINST TI MORE THAN ONE YEAR AFTER THE RELATED CAUSE OF ACTION HAS OCCURRED.
- 8.2 *Specific Limitations.* IN NO EVENT SHALL TI'S AGGREGATE LIABILITY FROM ANY WARRANTY OR OTHER OBLIGATION ARISING OUT OF OR IN CONNECTION WITH THESE TERMS AND CONDITIONS, OR ANY USE OF ANY TI EVM PROVIDED HEREUNDER, EXCEED THE TOTAL AMOUNT PAID TO TI FOR THE PARTICULAR UNITS SOLD UNDER THESE TERMS AND CONDITIONS WITH RESPECT TO WHICH LOSSES OR DAMAGES ARE CLAIMED. THE EXISTENCE OF MORE THAN ONE CLAIM AGAINST THE PARTICULAR UNITS SOLD TO USER UNDER THESE TERMS AND CONDITIONS SHALL NOT ENLARGE OR EXTEND THIS LIMIT.
9. *Return Policy.* Except as otherwise provided, TI does not offer any refunds, returns, or exchanges. Furthermore, no return of EVM(s) will be accepted if the package has been opened and no return of the EVM(s) will be accepted if they are damaged or otherwise not in a resalable condition. If User feels it has been incorrectly charged for the EVM(s) it ordered or that delivery violates the applicable order, User should contact TI. All refunds will be made in full within thirty (30) working days from the return of the components(s), excluding any postage or packaging costs.
10. *Governing Law:* These terms and conditions shall be governed by and interpreted in accordance with the laws of the State of Texas, without reference to conflict-of-laws principles. User agrees that non-exclusive jurisdiction for any dispute arising out of or relating to these terms and conditions lies within courts located in the State of Texas and consents to venue in Dallas County, Texas. Notwithstanding the foregoing, any judgment may be enforced in any United States or foreign court, and TI may seek injunctive relief in any United States or foreign court.

Mailing Address: Texas Instruments, Post Office Box 655303, Dallas, Texas 75265  
Copyright © 2016, Texas Instruments Incorporated

## IMPORTANT NOTICE

Texas Instruments Incorporated and its subsidiaries (TI) reserve the right to make corrections, enhancements, improvements and other changes to its semiconductor products and services per JESD46, latest issue, and to discontinue any product or service per JESD48, latest issue. Buyers should obtain the latest relevant information before placing orders and should verify that such information is current and complete. All semiconductor products (also referred to herein as "components") are sold subject to TI's terms and conditions of sale supplied at the time of order acknowledgment.

TI warrants performance of its components to the specifications applicable at the time of sale, in accordance with the warranty in TI's terms and conditions of sale of semiconductor products. Testing and other quality control techniques are used to the extent TI deems necessary to support this warranty. Except where mandated by applicable law, testing of all parameters of each component is not necessarily performed.

TI assumes no liability for applications assistance or the design of Buyers' products. Buyers are responsible for their products and applications using TI components. To minimize the risks associated with Buyers' products and applications, Buyers should provide adequate design and operating safeguards.

TI does not warrant or represent that any license, either express or implied, is granted under any patent right, copyright, mask work right, or other intellectual property right relating to any combination, machine, or process in which TI components or services are used. Information published by TI regarding third-party products or services does not constitute a license to use such products or services or a warranty or endorsement thereof. Use of such information may require a license from a third party under the patents or other intellectual property of the third party, or a license from TI under the patents or other intellectual property of TI.

Reproduction of significant portions of TI information in TI data books or data sheets is permissible only if reproduction is without alteration and is accompanied by all associated warranties, conditions, limitations, and notices. TI is not responsible or liable for such altered documentation. Information of third parties may be subject to additional restrictions.

Resale of TI components or services with statements different from or beyond the parameters stated by TI for that component or service voids all express and any implied warranties for the associated TI component or service and is an unfair and deceptive business practice. TI is not responsible or liable for any such statements.

Buyer acknowledges and agrees that it is solely responsible for compliance with all legal, regulatory and safety-related requirements concerning its products, and any use of TI components in its applications, notwithstanding any applications-related information or support that may be provided by TI. Buyer represents and agrees that it has all the necessary expertise to create and implement safeguards which anticipate dangerous consequences of failures, monitor failures and their consequences, lessen the likelihood of failures that might cause harm and take appropriate remedial actions. Buyer will fully indemnify TI and its representatives against any damages arising out of the use of any TI components in safety-critical applications.

In some cases, TI components may be promoted specifically to facilitate safety-related applications. With such components, TI's goal is to help enable customers to design and create their own end-product solutions that meet applicable functional safety standards and requirements. Nonetheless, such components are subject to these terms.

No TI components are authorized for use in FDA Class III (or similar life-critical medical equipment) unless authorized officers of the parties have executed a special agreement specifically governing such use.

Only those TI components which TI has specifically designated as military grade or "enhanced plastic" are designed and intended for use in military/aerospace applications or environments. Buyer acknowledges and agrees that any military or aerospace use of TI components which have **not** been so designated is solely at the Buyer's risk, and that Buyer is solely responsible for compliance with all legal and regulatory requirements in connection with such use.

TI has specifically designated certain components as meeting ISO/TS16949 requirements, mainly for automotive use. In any case of use of non-designated products, TI will not be responsible for any failure to meet ISO/TS16949.

### Products

Audio	<a href="http://www.ti.com/audio">www.ti.com/audio</a>
Amplifiers	<a href="http://amplifier.ti.com">amplifier.ti.com</a>
Data Converters	<a href="http://dataconverter.ti.com">dataconverter.ti.com</a>
DLP® Products	<a href="http://www.dlp.com">www.dlp.com</a>
DSP	<a href="http://dsp.ti.com">dsp.ti.com</a>
Clocks and Timers	<a href="http://www.ti.com/clocks">www.ti.com/clocks</a>
Interface	<a href="http://interface.ti.com">interface.ti.com</a>
Logic	<a href="http://logic.ti.com">logic.ti.com</a>
Power Mgmt	<a href="http://power.ti.com">power.ti.com</a>
Microcontrollers	<a href="http://microcontroller.ti.com">microcontroller.ti.com</a>
RFID	<a href="http://www.ti-rfid.com">www.ti-rfid.com</a>
OMAP Applications Processors	<a href="http://www.ti.com/omap">www.ti.com/omap</a>
Wireless Connectivity	<a href="http://www.ti.com/wirelessconnectivity">www.ti.com/wirelessconnectivity</a>

### Applications

Automotive and Transportation	<a href="http://www.ti.com/automotive">www.ti.com/automotive</a>
Communications and Telecom	<a href="http://www.ti.com/communications">www.ti.com/communications</a>
Computers and Peripherals	<a href="http://www.ti.com/computers">www.ti.com/computers</a>
Consumer Electronics	<a href="http://www.ti.com/consumer-apps">www.ti.com/consumer-apps</a>
Energy and Lighting	<a href="http://www.ti.com/energy">www.ti.com/energy</a>
Industrial	<a href="http://www.ti.com/industrial">www.ti.com/industrial</a>
Medical	<a href="http://www.ti.com/medical">www.ti.com/medical</a>
Security	<a href="http://www.ti.com/security">www.ti.com/security</a>
Space, Avionics and Defense	<a href="http://www.ti.com/space-avionics-defense">www.ti.com/space-avionics-defense</a>
Video and Imaging	<a href="http://www.ti.com/video">www.ti.com/video</a>

### TI E2E Community

[e2e.ti.com](http://e2e.ti.com)